



This is a digital copy of a book that was preserved for generations on library shelves before it was carefully scanned by Google as part of a project to make the world's books discoverable online.

It has survived long enough for the copyright to expire and the book to enter the public domain. A public domain book is one that was never subject to copyright or whose legal copyright term has expired. Whether a book is in the public domain may vary country to country. Public domain books are our gateways to the past, representing a wealth of history, culture and knowledge that's often difficult to discover.

Marks, notations and other marginalia present in the original volume will appear in this file - a reminder of this book's long journey from the publisher to a library and finally to you.

Usage guidelines

Google is proud to partner with libraries to digitize public domain materials and make them widely accessible. Public domain books belong to the public and we are merely their custodians. Nevertheless, this work is expensive, so in order to keep providing this resource, we have taken steps to prevent abuse by commercial parties, including placing technical restrictions on automated querying.

We also ask that you:

- + *Make non-commercial use of the files* We designed Google Book Search for use by individuals, and we request that you use these files for personal, non-commercial purposes.
- + *Refrain from automated querying* Do not send automated queries of any sort to Google's system: If you are conducting research on machine translation, optical character recognition or other areas where access to a large amount of text is helpful, please contact us. We encourage the use of public domain materials for these purposes and may be able to help.
- + *Maintain attribution* The Google "watermark" you see on each file is essential for informing people about this project and helping them find additional materials through Google Book Search. Please do not remove it.
- + *Keep it legal* Whatever your use, remember that you are responsible for ensuring that what you are doing is legal. Do not assume that just because we believe a book is in the public domain for users in the United States, that the work is also in the public domain for users in other countries. Whether a book is still in copyright varies from country to country, and we can't offer guidance on whether any specific use of any specific book is allowed. Please do not assume that a book's appearance in Google Book Search means it can be used in any manner anywhere in the world. Copyright infringement liability can be quite severe.

About Google Book Search

Google's mission is to organize the world's information and to make it universally accessible and useful. Google Book Search helps readers discover the world's books while helping authors and publishers reach new audiences. You can search through the full text of this book on the web at <http://books.google.com/>

Library
of the
University of Wisconsin

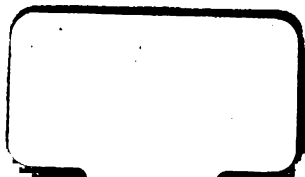





MECHANICS OF ENGINEERING.

COMPRISING

STATICS AND DYNAMICS OF SOLIDS ; THE MECHANICS OF THE
MATERIALS OF CONSTRUCTION, OR STRENGTH AND ELASTICITY
OF BEAMS, COLUMNS, SHAFTS, ARCHES, ETC. ; AND THE
PRINCIPLES OF HYDRAULICS AND PNEUMATICS,
WITH APPLICATIONS.

FOR USE IN TECHNICAL SCHOOLS.

BY

IRVING P. CHURCH, C.E.,

PROFESSOR OF APPLIED MECHANICS, COLLEGE OF CIVIL ENGINEERING,
CORNELL UNIVERSITY.

*EIGHTH EDITION OF "STATICS AND DYNAMICS."
SEVENTH EDITION OF "MECHANICS AND MATERIALS."
FIFTH EDITION OF "MECHANICS OF FLUIDS."*

THIRD THOUSAND.

NEW YORK:

JOHN WILEY & SONS,

53 EAST TENTH STREET.

1893.

Copyright, 1890,
BY
JAMES P. CHURCH.

Electrotyped by
DRUMMOND & NEW,
New York

Printed by
FERRIS BROS.,
New York.

31510
29 My '94

SD

C47

PREFACE.

For the engineering student, pursuing the study of Applied Mechanics as part of his professional training, and not as additional mathematical culture, not only is a thoroughly systematic, clear, and consistent treatment of the subject quite essential, but one which presents the quantities and conceptions involved in as practical and concrete a form as possible, with all the aids of the printer's and engraver's arts; and especially one which, besides showing the derivation of formulæ from principles, illustrates, inculcates, and lays stress on *correct numerical substitution* and the consistent and proper use of units of measurement; for without this no reliable results can be reached, and the principal object of these formulæ is frustrated.

With these requirements in view, and aided by the experience of ten years in teaching the Mechanics of Engineering at this institution, the writer has been led to prepare the present work, in which attention is called to the following features:

The diagrams are very numerous (about one to every page; an appeal to the eye is often worth a page of verbal description).

The symbols for distances, angles, forces, etc., used in the algebraic work are, as far as possible, inserted directly in the diagrams, rendering the latter full and explicit, and thus saving time and mental effort to the student. In problems in Dynamics three kinds of arrows are used to distinguish forces, velocities, and accelerations, respectively, and thus to prevent confusion of ideas.

Illustrations and examples of a practical nature, both algebraic and numerical, are of frequent occurrence.

Formulæ are divided into two classes; those (homogeneous) admitting of the use of any system of units whatever for measurements of force, space, mass, and time, in numerical substitution; and those which are true for specified units only. Attention is repeatedly directed to the matter of correct numerical substitution, especially in Dynamics, where time and mass, as well as force and space, are among the quantities considered. The importance, in this connection, of frequent mention of the *quality* of the various kinds of quantity employed, is also recognized, and a corresponding phraseology adopted.

The definition of force (§3) is made to include and illustrate Newton's law of action and reaction, the misconception of which leads to such lengthy discussions in technical journals every few years.

In the matter of "Centrifugal force," the artificial method, so commonly adopted, of regarding a particle moving uniformly in a circle as in equilibrium, i. e., acted on by a balanced system of forces, one of which is the "Centrifugal force," has been avoided, as being at variance with a system of Mechanics founded on Newton's laws, according to the first of which a particle moving in any other than a straight line cannot be in equilibrium. In such a system of Mechanics nothing can

be recognized as a force which is not a definite pull, push, pressure, rub, attraction or repulsion, of one body upon, or against, another.

It is true that the artificial nature of the method referred to is in some text-books fully explained in the context, (in Goodeve's Steam Engine, for instance, in treating the governor ball,) but is too often not mentioned at all, so that the student risks being led into error in attempting kindred problems by what would then seem to him correct methods.

The general theorem of Work and Energy in machines is developed gradually by definite and limited steps, in preference to giving a single demonstration which, from its generality, might be too vague and abstruse to be readily grasped by the student.

In the use of the Calculus, (in the elements of which the student is supposed to have had the training usually given in technical schools by the end of the second year) the integral sign is always used to indicate summation (except on p. 357) while the name of *anti-derivative* of a given function (of one variable) has been adopted for that function whose derivative, or differential co-efficient, is the given function (see §253.)

The signs \perp and \parallel are used for perpendicular and parallel, respectively.

In Torsion and Flexure of Beams, the well worn and simple theories of Navier have been thought sufficient for establishing practical formulæ for safe loads and deflections of beams and shafts; and prominence has been given to the methods of designing the cross-sections and riveting of built-beams and plate-girders, forming the basis of the tables and rules usually given in the pocket-books of our iron and steel manufacturers.

The analytical treatment of the continuous girder is not presented in the general case, preference being given to the graphic method by Mohr, as greatly superior in simplicity, directness, and interest. For similar reasons the graphics of the arch of masonry is to be preferred to the analytical chapter on Linear Arches, whose insertion is chiefly a concession to the mathematical student, as are also §§ 119, 198, 234, 235, 264, 265, 266, 284, 287, 291, and 297.

The graphics of curved beams or arch ribs is made to precede that of the straight girder, since the treatment of the latter as a particular case of the former is then a comparatively simple matter. Hence Prof. Eddy's methods* (inserted by his kind permission) for the arch rib of hinged ends, and also that of fixed ends, are presented as special geometrical devices, instead of being based on Prof. Eddy's general theorem (involving a straight girder of the same section and mode of support).

Acknowledgment is also due Prof. Burr and Prof. Robinson, for their cordial consent to the use of certain items and passages from their works; (see §§ 206, 212, 220, and 297.)

* See pp. 14 and 25 of "Researches in Graphical Statics," by Prof. H. T. Eddy, C.E., Ph. D.; published by D. Van Nostrand, New York, 1878; reprinted from Van Nostrand's Magazine for 1877.

PREFACE.

Advantage has been taken of the results of the most recent experimental investigations in Hydraulics in assigning values of the numerous coefficients necessary in this science. The researches of Messrs. Fteley and Stearns in 1880 and of M. Bazin in 1887 on the flow of water over weirs, and of Mr. Clemens Herschel in testing his invention the "Venturi Water-meter," are instances in point; as also some late experiments on the transmission of compressed air and of natural gas, and Mr. Freeman's extensive investigations in the Hydraulics of Fire-streams and resistance of Fire-hose, p. 832. (See *Transac. Am. Soc. Civ. Eng.* for Nov. 1889.)

In dealing with fluid tension care has been taken to use the absolute pressure and not simply the excess over atmospheric, thus avoiding the occurrence of the term "negative pressure;" this precaution being specially necessary in the treatment of gaseous fluids.

Though space has forbidden dealing at any great length with the action of fluid motors, sufficient matter is given in treating of the mode of working of steam, gas, and hot-air engines, air-compressors, and pumping-engines, together with numerical examples, to be of considerable advantage, it is thought, to students not making a specialty of mechanical engineering.

Special acknowledgment is due to Col. J. T. Fanning, the well-known author of "Hydraulic and Water-supply Engineering," for his consent to the use of an abridgment of the table of coefficients for friction of water in pipes, given in that work; and to Prof. C. L. Crandall, of this university, for permission to incorporate the chapter on Retaining-Walls.

References to original research in the Hydraulic Laboratory of the Civil Engineering Department at this institution will be found on pp. 694 and 729.

CORNELL UNIVERSITY, ITHACA, N. Y.,
January, 1890.



TABLE OF CONTENTS.

[MECHANICS OF SOLIDS.]

PRELIMINARY CHAPTER.

	PAGE
§§ 1-15a. Definitions. Kinds of Quantity. Homogeneous Equations. Parallelogram of Forces.....	1

PART I. STATICS.

CHAPTER I. STATICS OF A MATERIAL POINT.

§§ 16-19. Composition and Equilibrium of Concurrent Forces....	8
----------------------------------------------------------------	---

CHAPTER II. PARALLEL FORCES AND THE CENTRE OF GRAVITY.

§§ 20-22. Parallel Forces.....	13
§§ 23-27b. Centre of Gravity. Problems. Centrobatic Method...	18

CHAPTER III. STATICS OF A RIGID BODY.

§§ 28-34. Couples.....	27
§§ 35-39. Composition and Equilibrium of Non-concurrent Forces.	31

CHAPTER IV. STATICS OF FLEXIBLE CORDS.

§§ 40-43. Postulates. Suspended Weights. Parabolic Cord. Catenary.....	43
------------------------------------------------------------------------	----

PART II. DYNAMICS.

CHAPTER I. RECTILINEAR MOTION OF A MATERIAL POINT.

§§ 49-55. Uniform Motion. Falling Bodies. Newton's Laws. Mass.....	49
§§ 56-60. Uniformly Accelerated Motion. Graphic Representations. Variably Accelerated Motions. Impact...	54

CHAPTER II. VIRTUAL VELOCITIES.

§§ 61-69. Definitions and Propositions. Connecting-rod. Problems.....	67
-----------------------------------------------------------------------	----

CHAPTER III. CURVILINEAR MOTION OF A MATERIAL POINT.		PAGE
§§ 70-74.	Composition of Motions, of Velocities, etc. General Equations	73
§§ 75-84	Normal Acceleration. Centripetal and Centrifugal Forces. Simple Pendulums. Projectiles. Relative Motion.....	77
CHAPTER IV. MOMENT OF INERTIA.		
§§ 85-94.	Plane Figures. Rigid Bodies. Reduction Formulæ. The Rectangle, Triangle, etc. Compound Plane Figures. Polar Moment of Inertia.....	91
§§ 95-104	Rod. Thin Plates. Geometric Solids.....	98
§§ 105-107.	Numerical Substitution. Ellipsoid of Inertia.....	103
CHAPTER V. DYNAMICS OF A RIGID BODY.		
§§ 108-115.	Translation. Rotation about a Fixed Axis. Centre of Percussion.....	105
§§ 116-121.	Torsion Balance. Compound Pendulum. The Fly-wheel	116
§§ 122-123.	Uniform Rotation. "Centrifugal Action." Free Axes.	125
§§ 124-126.	Rolling Motions. Parallel Rod of Locomotive.....	130
CHAPTER VI. WORK, ENERGY, AND POWER.		
§§ 127-134.	Work. Power. Horse-power. Kinetic Energy.....	133
§§ 135-138.	Steam-hammer. Pile-driving. Inelastic Impact.....	138
§§ 139-141.	Rotary Motion. Equivalent Systems of Forces. Any Motion of a Rigid Body.....	143
§§ 142-146.	Work and Kinetic Energy in a Moving Machine of Rigid Parts.....	147
§§ 147-155.	Power of Motors. Potential Energy. Heat, etc. Dynamometers. Atwood's Machine. Boat-rowing. Examples.....	153
CHAPTER VII. FRICTION.		
§§ 156-164.	Sliding Friction. Its Laws. Bent Lever.....	164
§§ 165-171.	Axle-friction. Friction Wheels. Pivots. Belting. Transmission of Power by Belting.....	175
§§ 172-177.	Rolling Friction. Brakes. Engine-friction. Anomalies in Friction. Rigidity of Cordage. Examples.	186

PART III. STRENGTH OF MATERIALS.

(OR MECHANICS OF MATERIALS.)

CHAPTER I. ELEMENTARY STRESSES AND STRAINS.

§§ 178-182.	Stress and Strain; of Two Kinds. Oblique Section of Rod in Tension.....	195
§§ 182a-190.	Hooke's Law. Elasticity. Safe Limit. Elastic Limit. Rupture. Modulus of Elasticity. Isotropes. Resilience. Internal Stress. Temperature Stresses.....	201

TENSION.

§§ 191-195.	Hooke's Law by Experiment. Strain Diagrams. Lateral Contraction. Modulus of Tenacity....	207
§§ 196-199.	Resilience of Stretched Prism. Load Applied Suddenly. Prism Under Its Own Weight. Solid of Uniform Strength. Temperature Stresses..	218

COMPRESSION OF SHORT BLOCKS.

§§ 200-202.	Short and Long Columns. Remarks on Crushing... 218
-------------	----------------------------------------------------

EXAMPLES IN TENSION AND COMPRESSION.

§§ 203-206.	Tables. Examples. Factor of Safety. Practical Notes.....	220
-------------	----------------------------------------------------------	-----

SHEARING.

§§ 207-213.	Rivets. Shearing Distortion. Table. Punching. Examples.....	225
-------------	-------------------------------------------------------------	-----

CHAPTER II. TORSION.

§§ 214-220.	Angle and Moment of Torsion. Torsional Strength, Stiffness, and Resilience. Non-Circular Shafts.....	238
§§ 221-223.	Transmission of Power. Autographic Testing Machine. Examples.....	238

CHAPTER III. FLEXURE OF HOMOGENEOUS PRISMS UNDER PERPENDICULAR FORCES IN ONE PLANE.

§§ 224-232a.	The Common Theory. Elastic Forces. Neutral Axis. The "Shear" and "Moment." Flexural Strength and Stiffness. Radius of Curvature. Resilience.....	244
--------------	--------------------------------------------------------------------------------------------------------------------------------------------------	-----

ELASTIC CURVES.

§§ 233-238.	Single Central Load; at Rest, and Applied Suddenly. • Eccentric Load. Uniform Load. Cantilever..	252
-------------	-----------------------------------------------------------------------------------------------------	-----

SAFE LOADS.

- §§ 239-246. Maximum Moment. Shear — x -Derivative of the Moment. Simple Beams With Various Loads. Comparative Strength and Stiffness of Rectangular Beams..... 263
- §§ 247-252. Moments of Inertia. "Shape Iron." I-Beams, Etc. Cantilevers. Tables. Numerical Examples... 273

SHEARING STRESSES IN FLEXURE.

- §§ 253-257. Shearing Stress Parallel to Neutral Surface; and in Cross Section. Web of I-Beam. Riveting of Built Beams 284

SPECIAL PROBLEMS IN FLEXURE.

- §§ 258-265. Designing Sections of Built Beams. Moving Loads. Special Cases of Quiescent Loads. Hydrostatic Load..... 295
- §§ 266-270. Derivatives of Ordinate of Elastic Curve. Weight Falling on Beam. Crank Shaft. Other Shafts. 310

CHAPTER IV. FLEXURE; CONTINUED.

CONTINUOUS GIRDERS.

- §§ 271-276. Analytical Treatment of Symmetrical Cases of Beams on Three Supports; also, Built in; (see § 391).. 320

THE DANGEROUS SECTION IN NON-PRISMATIC BEAMS.

- §§ 277-279. Double Truncated Wedge, Pyramid, and Cone..... 333

NON-PRISMATIC BEAMS OF UNIFORM STRENGTH.

- §§ 280-289. Parabolic and Wedge-Shaped Beams. I-Beam. Elliptical Beam and Cantilevers..... 335

DEFLECTION OF BEAMS OF UNIFORM STRENGTH.

- §§ 290-293. Parabolic and Wedge-Shaped Beams. Special Problems..... 349

CHAPTER V. FLEXURE OF PRISMATIC BEAMS UNDER OBLIQUE FORCES.

- §§ 294-301. Gravity and Neutral Axes. Shear, Thrust, and Stress-Couple. Strength and Stiffness of Oblique Cantilever. Hooks. Crane..... 347

CHAPTER VI. FLEXURE OF LONG COLUMNS.

§§ 302-306.	End-Conditions. Euler's Formula. "Incipient Flexure." Hodgkinson's Formulae. Rankine's Formula.....	363
§§ 309-314.	Radii of Gyration. Built Columns. Trussed Girders. Buckling of Web-Plates. Examples.....	376

CHAPTER VII. LINEAR ARCHES (OF BLOCKWORK.)

§§ 315-323.	Inverted Catenary. Parabolic Arch. Circular Arch. Transformed Catenary as Arch.....	386
-------------	-------------------------------------------------------------------------------------	-----

CHAPTER VIII. ELEMENTS OF GRAPHICAL STATICS

§§ 324-326.	Force Polygons. Concurrent and Non-Concurrent Forces in a Plane. Force Diagrams. Equilibrium Polygons.....	397
§§ 327-333.	Constructions for Resultant, Pier-Reactions, and Stresses in Roof Truss. Bow's Notation. The Special Equilibrium Polygon.....	402

CHAPTER IX. GRAPHICAL STATICS OF VERTICAL FORCES.

§§ 333-336.	Jointed Rods. Centre of Gravity.....	412
§§ 337-343.	Useful Relations Between Force Diagrams and Their Equilibrium Polygons.....	415

CHAPTER X. RIGHT ARCHES OF MASONRY.

§§ 344-352.	Definitions. Mortar and Friction. Pressure in Joints. Conditions of Safe Equilibrium. True Linear Arch.....	421
§§ 353-357.	Arrangement of Data for Graphic Treatment.....	428
§§ 358-362.	Graphical Treatment of Arch. Symmetrical and Unsymmetrical Cases.....	431

CHAPTER XI. ARCH-RIBS.

§§ 364-374.	Mode of Support. Special Equilibrium Polygon and its Force Diagram. Change in Angle Between Rib Tangents. Displacement of Any Point on Rib.....	438
§§ 374a-378a.	Graphical Arithmetic. Summation of Products. Moment of Inertia by Graphics. Classification of Arch-Ribs.....	450
§§ 379-383.	Prof. Eddy's Graphical Method for Arch-Ribs of Hinged Ends; and of Fixed Ends. Stress Diagrams. Temperature Stresses. Braced Arches.....	461

HORIZONTAL STRAIGHT GIRDERS.

- §§ 389-390. Prismatic Girder Supported at the Extremities, also with Ends Fixed Horizontally..... 479

CHAPTER XII. GRAPHICS OF CONTINUOUS GIRDERS.

- §§ 391-397. The Elastic Curve an Equilibrium Polygon. Mohr's Theorem. Example and Numerical Case. End-Tangents. Re-arrangement of Moment-Area.. 484
- §§ 398-405. Positive Moment-Areas; Amount and Gravity Vertical. Construction of the "False Polygons" in Any Given Case. Moment Curves, Shears, and Reactions. Numerical Example in Detail. Remarks 497

[CONTENTS OF "MECHANICS OF FLUIDS."]

PART IV.—HYDRAULICS.

CHAPTER I.—DEFINITIONS. FLUID PRESSURE. HYDRO-
STATICS BEGUN.

	PAGE
§§ 406-417. Perfect fluids. Liquids and Gases. Principle of "Equal Transmission of Pressure." Non-planar Pistons...	515
§§ 418-427. Hydraulic Press. Free Surface of Liquid. Barometers and Manometers. Safety-valves. Strength of Thin Hollow Cylinders against Bursting and Collapse...	526

CHAPTER II.—HYDROSTATICS CONTINUED. PRESSURE OF
LIQUIDS IN TANKS AND RESERVOIRS.

§§ 428-434. Liquid in Motion, but in "Relative Equilibrium." Pressure on Bottom and Sides of Vessels. Centre of Pressure of Rectangles, Triangles, etc.....	540
§§ 435-444. Stability of Rectangular and Trapezoidal Walls against Water Pressure. High Masonry Dams. Proposed Quaker Bridge Dam. Earthwork Dam. Water Pressure on both Sides of a Gate.....	554

CHAPTER III.—EARTH PRESSURE AND RETAINING WALLS.

§§ 445-455. Angle of Repose. Wedge of Maximum Thrust. Geometrical Constructions. Resistance of Retaining Walls. Results of Experience	572
---------------------------------------------------------------------------------------------------------------------------------------------	-----

CHAPTER IV.—HYDROSTATICS CONTINUED. IMMERSION
AND FLOTATION.

§§ 456-460. Buoyant Effort. Examples of Immersion. Specific Gravity. Equilibrium of Flotation. Hydrometer..	586
§§ 461-465. Depth of Flotation. Draught and Angular Stability of Ships. The Metacentre.....	592

	PAGE
CHAPTER V.—HYDROSTATICS CONTINUED. GASEOUS FLUIDS.	
§§ 466-478. Thermometers. Absolute Temperature. Gases and Vapors. Critical Temperature. Law of Charles. Closed Air-manometer. Mariotte's Law. Mixture of Gases. Barometric Levelling. Adiabatic Change..	604
§§ 479-489. Work Done in Steam-engine Cylinders. Expanding Steam. Graphic Representation of Change of State of Gas. Compressed-air Engine. Air-compressor. Hot-air Engines. Gas-engines. Heat-efficiency. Duty of Pumping-engines. Buoyant Effort of the Atmosphere.....	624
CHAPTER VI.—HYDRODYNAMICS BEGUN. STEADY FLOW OF LIQUIDS THROUGH PIPES AND ORIFICES.	
§§ 489a-495. Phenomena of a "Steady Flow." Bernoulli's Theorem for Steady Flow without Friction, and Applications. Orifice in "Thin Plate".....	646
§§ 496-500. Rounded Orifice. Various Problems involving Flow through Orifices. Jet from Force-pump. Velocity and Density; Relation. Efflux under Water. Efflux from Vessel in Motion. Barker's Mill.....	668
§§ 501-508. Efflux from Rectangular and Triangular Orifices. Poncelet's Experiments. Perfect and Complete Contraction, etc. Overfall Weirs. Experiments of Francis, Fteley and Stearns, and Bazin. Short Pipes or Tubes.....	672
§§ 509-518. Conical Tubes. Venturi's Tube. Fluid Friction. Froude's Experiments. Bernoulli's Theorem with Friction. Hydraulic Radius. Loss of Head. Problems involving Friction Heads in Pipes. Accumulator.....	692
§§ 518a-518. Loss of Head in Orifices and Short Pipes. Coefficient of Friction of Water in Pipes. Fanning's Table. Petroleum Pumping. Flow through Long Pipes..	708
§§ 519-526. Chézy's Formula. Fire-engine Hose. Pressure-energy. Losses of Head due to Sudden Enlargement of Section; Borda's Formula. Diaphragm in Pipe. Venturi Water-meter.....	714
§§ 527-536. Sudden Diminution of Section. Losses of Head due to Elbows, Bends, Valve-gates, and Throttle-valves. Examples, Prof. Bellinger's Experiments on Elbows. Siphons. Branching Pipes. Time of Emptying Vessels of Various Forms; Prisms, Wedges Pyramids, Cones, Paraboloids, Spheres, Obelisks, and Volumes of Irregular Form using Simpson's Rule..	727

	PAGE
CHAPTER VII.—HYDRODYNAMICS, CONTINUED; STEADY FLOW OF WATER IN OPEN CHANNELS.	
§§ 538-542a. Nomenclature. Velocity Measurements and Instruments for the same Ritchie-Haskell Direction Current-meter. Change of Velocity with Depth. Pitot's Tube. Hydrometric Pendulum. Woltmann's Mill. Gauging Streams. Chézy's Formula for Uniform Motion in Open Channel. Experiments.....	749
§§ 542b-547. Kutter's Formula. Sections of Least Resistance. Trapezoidal Section of Given Side Slope and Minimum Friction. Variable Motion in Open Channel. Bends. Formula introducing Depths at End Sections. Backwater.....	759
CHAPTER VIII.—DYNAMICS OF GASEOUS FLUIDS.	
§§ 548-556. Theorem for Steady Flow of Gases without Friction. Flow through Orifices by Water-formula; with Isothermal Expansion; with Adiabatic Expansion. Maximum Flow of Weight. Experimental Coefficients for Orifices and Short Pipes. Flow considering Velocity of Approach.....	773
§§ 557-561a. Transmission of Compressed Air through Long Pipes. Experiments in St. Gothard Tunnel. Pipes of Variable Diameter. The Piping of Natural Gas.....	786
CHAPTER IX.—IMPULSE AND RESISTANCE OF FLUIDS.	
§§ 562-569. Reaction of a Jet of Liquid. Impulse of Jet on Curved Vanes, Fixed and in Motion. Pitot's Tube. The California "Hurdy-gurdy." Impulse on Plates. Plates Moving in a Fluid. Plates in Currents of Fluid.....	798
§§ 570-575. Wind-pressure. Smithsonian Scale. Mechanics of the Sail-boat. Resistance of Still Water to Immersed Solids in Motion. Spinning Ball, Deviation from Vertical Plane. Robinson's Cup-anemometer. Resistance of Ships. Transporting Power of a Current. Fire-streams, Hose-friction, etc	818



MECHANICS OF ENGINEERING.

PRELIMINARY CHAPTER.

1. **Mechanics** treats of the mutual actions and relative motions of material bodies, solid, liquid, and gaseous; and by *Mechanics of Engineering* is meant a presentment of those principles of pure mechanics, and their applications, which are of special service in engineering problems.

2. **Kinds of Quantity.**—Mechanics involves the following fundamental kinds of quantity: **Space**, of one, two, or three dimensions, i.e., length, surface, or volume, respectively; **time**, which needs no definition here; **force** and **mass**, as defined below; and **abstract numbers**, whose values are independent of arbitrary units, as, for example, a ratio.

3. **Force.**—A force is one of a pair of equal, opposite, and simultaneous actions between two bodies, by which the state* of their motions is altered or a change of form in the bodies themselves is effected. Pressure, attraction, repulsion, and traction are instances in point. Muscular sensation conveys the idea of force, while a spring-balance gives an absolute measure of it, a beam-balance only a relative measure. In accordance with Newton's third law of motion, that action and reaction are equal, opposite, and simultaneous, forces always occur in pairs; thus, if a pressure of 40 lbs. exists between bodies *A* and *B*, if *A* is considered by itself (i.e., "free"), apart from all other bodies whose actions upon it are called forces, among these forces will be one of 40 lbs. directed from *B* toward *A*. Similarly, if *B* is under consideration, a force

* The state of motion of a small body under the action of no force, or of balanced forces, is either absolute rest, or uniform motion in a right line. If the motion is different from this, the fact is due to the action of an unbalanced force (§ 54).

of 40 lbs. directed from A toward B takes its place among the forces acting on B . This is the interpretation of Newton's third law.

In conceiving of a force as applied at a certain point of a body it is useful to imagine one end of an imponderable spiral spring in a state of compression (or tension) as attached at the given point, the axis of the spring having the given direction of the force.

4. Mass is the quantity of matter in a body. The masses of several bodies being proportional to their weights at the same locality on the earth's surface, in physics the weight is taken as the mass, but in practical engineering another mode is used for measuring it (as explained in a subsequent chapter), viz.: the mass of a body is equal to its weight divided by the acceleration of gravity in the locality where the weight is taken, or, symbolically, $M = G \div g$. This quotient is a constant quantity, as it should be, since the mass of a body is invariable wherever the body be carried.

5. Derived Quantities.—All kinds of quantity besides the fundamental ones just mentioned are compounds of the latter, formed by multiplication or division, such as velocity, acceleration, momentum, work, energy, moment, power, and force-distribution. Some of these are merely names given for convenience to certain combinations of factors which come together not in dealing with first principles, but as a result of common algebraic transformations.

6. Homogeneous Equations are those of such a form that they are true for any arbitrary system of units, and in which all terms combined by algebraic addition are of the same kind.

Thus, the equation $s = \frac{gt^2}{2}$ (in which g = the acceleration of gravity and t the time of vertical fall of a body in vacuo, from rest) will give the distance fallen through, s , whatever units be adopted for measuring time and distance. But if for

g we write the numerical value 32.2, which it assumes when time is measured in seconds and distance in feet, the equation $s = 16.1t^2$ is true for those units alone, and the equation is not of homogeneous form. Algebraic combination of homogeneous equations should always produce homogeneous equations; if not, some error has been made in the algebraic work. If any equation derived or proposed for practical use is not homogeneous, an explicit statement should be made in the context as to the proper units to be employed.

7. Heaviness.—By heaviness of a substance is meant the weight of a cubic unit of the substance. E.g. the heaviness of fresh water is 62.5, in case the unit of force is the pound, and the foot the unit of space; i.e., a cubic foot of fresh water weighs 62.5 lbs. In case the substance is not uniform in composition, the heaviness varies from point to point. If the weight of a homogeneous body be denoted by G , its volume by V , and the heaviness of its substance by γ , then $G = V\gamma$.

WEIGHT IN POUNDS OF A CUBIC FOOT (i.e., THE HEAVINESS) OF VARIOUS MATERIALS

Anthracite, solid.....	100	Masonry, dry rubble.....	138
“ broken.....	57	“ dressed granite or	
Brick, common hard.....	125	limestone.....	165
“ soft.....	100	Mortar.....	100
Brick-work, common.....	112	Petroleum.....	55
Concrete.....	125	Snow.....	7
Earth, loose.....	72	“ wet.....	15 to 50
“ as mud.....	102	Steel.....	490
Granite.....	164 to 172	Timber.....	25 to 60
Ice.....	58	Water, fresh.....	62.5
Iron, cast.....	450	“ sea.....	64.0
“ wrought.....	480		

8. Specific Gravity, is the ratio of the heaviness of a material to that of water, and is therefore an abstract number.

9. A Material Point is a solid body, or small particle, whose dimensions are practically nothing, compared with its range of motion.

10. **A Rigid Body** is a solid, whose distortion or change of form under any system of forces to be brought upon it in practice is, for certain purposes, insensible.

11. **Equilibrium.**—When a system of forces applied to a body produces the same effect as if no force acted, so far as the *state of motion* of the body is concerned, they are said to be balanced, or to be in equilibrium. [If no force acts on a material point it remains at rest if already at rest; but if already in motion it continues in motion, and *uniformly* (equal spaces in equal times), in a right line in direction of its original motion. See § 54.]

12. **Division of the Subject.**—*Statics* will treat of bodies at rest, i.e., of balanced forces or equilibrium; *dynamics*, of bodies in motion; *strength of materials* will treat of the effect of forces in distorting bodies; *hydraulics*, of the mechanics of liquids and gases (thus including *pneumatics*).

13. **Parallelogram of Forces.**—Duchayla's Proof. To fully determine a force we must have given its amount, its direction, and its point of application in the body. It is generally denoted in diagrams by an arrow. It is a matter of experience that besides the point of application already spoken of any other may be chosen in the line of action of the force. This is called the transmissibility of force; i.e., so far as the *state of motion* of the body is concerned, a force may be applied anywhere in its line of action.

The **Resultant** of two forces (called its components) applied at a point of a body is a single force applied at the same point, which will replace them. To prove that this resultant is given in amount and position by the diagonal of the parallelogram formed on the two given forces (conceived as laid off to some scale, so many pounds to the inch, say), Duchayla's method requires four postulates, viz.: (1) the resultant of two forces must lie in the same plane with them; (2) the resultant of two equal forces must bisect the angle between them; (3) if one of the two forces be increased, the angle between the other force and the resultant will be greater than before; and (4) the transmissibility of force, already mentioned. Granting these, we proceed as follows (Fig. 1): Given the two forces P and $Q =$

$P' + P''$ (P' and P'' being each equal to P , so that $Q = 2P$), applied at O . Transmit P'' to A . Draw the parallelograms OB and AD ; OD will also be a parallelogram. By postulate (2), since OB is a rhombus, P and P' at O may be replaced by a single force R' acting through B . Transmit R' to B and replace it by P and P' . Transmit P from B to A , P' from B to D . Similarly P and P'' , at A , may be replaced by a single force R'' passing through D ; transmit it there and resolve it into P and P'' . P' is already at D . Hence P and $P' + P''$, acting at D , are equivalent to P and $P' + P''$ acting at O , in their respective directions. Therefore the resultant of P and $P' + P''$ must lie in the line OD , the diagonal of the parallelogram formed on P and $Q = 2P$ at O . Similarly

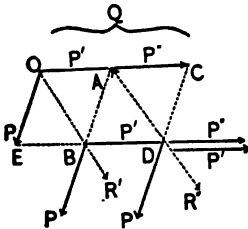

FIG. 1.

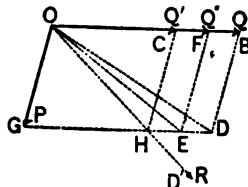

FIG. 2.

this may be proved (that the diagonal gives the *direction* of the resultant) for any two forces P and mP ; and for any two forces nP and mP , m and n being any two whole numbers, i.e., for any two commensurable forces. When the forces are incommensurable (Fig. 2), P and Q being the given forces, we may use a *reductio ad absurdum*, thus: Form the parallelogram OD on P and Q applied at O . Suppose for an instant that R the resultant of P and Q does not follow the diagonal OD , but some other direction, as OD' . Note the intersection H , and draw HC parallel to DB . Divide P into equal parts, each less than HD ; then in laying off parts equal to these from O along OB , a point of division will come at some point F between C and B . Complete the parallelogram $OFEG$. The force $Q'' = OF$ is commensurable with P , and hence their

resultant acts along OE . Now Q is greater than Q'' , while R makes a less angle with P than OE , which is contrary to postulate (3); therefore R cannot lie outside of the line OD . Q. E. D.

It still remains to prove that the resultant is represented in amount, as well as position, by the diagonal. OD (Fig. 3) is the direction of R the resultant of P and Q ; required its amount. If R' be a force equal and opposite to R it will balance P and Q ; i.e., the resultant of R' and P must lie in the line QO prolonged (besides being equal to Q). We can therefore determine R' by drawing BA parallel to DO to intersect QO prolonged in A ; and then complete the parallelogram on BA and BO .* Since $OFAB$ is a parallelogram R' must $=\overline{BA}$, and since $OABD$ is a parallelogram $\overline{BA}=\overline{OD}$; therefore $R'=\overline{OD}$ and also $R=\overline{OD}$. Q. E. D.

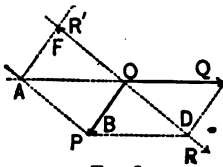

FIG. 3.

Corollary.—The resultant of three forces applied at the same point is the diagonal of the parallelepiped formed on the three forces.

14. **Concurrent forces** are those whose lines of action intersect in a common point, while **non-concurrent forces** are those which do not so intersect; results obtained for a system of concurrent forces are really derivable, as particular cases, from those pertaining to a system of non-concurrent forces.

15. **Resultant.**—A single force, the action of which, as regards the *state of motion* of the body acted on, is equivalent to that of a number of forces forming a system, is said to be the **Resultant** of that system, and may replace the system; and conversely a force which is equal and opposite to the resultant of a system will balance that system, or, in other words, when it is combined with that system there will result a new system in equilibrium; this (ideal) force is called the **Anti-resultant**.

In general, as will be seen, a given system of forces can al-

* R' must $=\overline{OF}$; for if $R' >$ or $< \overline{OF}$, the diagonal formed on R' and P cannot take the direction of QO prolonged

ways be replaced by two single forces, but these two can be combined into a single resultant only in particular cases.

15a. Equivalent Systems are those which may be replaced by the same set of two single forces—or, in other words, those which have the same effect, as to state of motion, upon the given body.

15b. Formulae.—If in Fig. 8 the forces P and Q and the angle $\alpha = \angle POQ$ are given, we have, for the resultant,

$$R = \overline{OD} = \sqrt{P^2 + Q^2 + 2PQ \cos \alpha}.$$

(If α is $> 90^\circ$ its cosine is negative.) In general, given any three parts of either plane triangle ODQ , or ODB , the other three may be obtained by ordinary trigonometry. Evidently if $\alpha = 0$, $R = P + Q$; if $\alpha = 180^\circ$, $R = P - Q$; and if $\alpha = 90^\circ$, $R = \sqrt{P^2 + Q^2}$.

15c. Varieties of Forces.—Great care should be used in deciding what may properly be called forces. The latter may be divided into actions *by contact*, and actions *at a distance*. If pressure exists between two bodies and they are perfectly smooth at the surface of contact, the *pressure* (or *thrust*, or *compressive action*), of one against the other constitutes a force, whose direction is normal to the tangent plane at any point of contact (a matter of experience); while if those surfaces are not smooth there may also exist mutual tangential actions or *friction*. (If the bodies really form a continuous substance at the surface considered, these tangential actions are called *shearing forces*.) Again, when a rod or wire is subjected to tension, any portion of it is said to exert a *pull* or *tensile force* upon the remainder; the ability to do this depends on the property of cohesion. The foregoing are examples of actions by contact.

Actions at a distance are exemplified in the mysterious *attractions*, or *repulsions*, observable in the phenomena of gravitation, electricity, and magnetism, where the bodies concerned are not necessarily in contact. By the term *weight* we shall always mean the *force* of the earth's attraction on the body in question, and not the amount of matter in it.

[NOTE.—In some common phrases, such as "The tremendous force" of a heavy body in rapid motion, the word force is not used in a technical sense, but signifies energy (as explained in Chap. VI.). The mere fact that a body is in motion, whatever its mass and velocity, does not imply that it is under the action of any force, necessarily. For instance, at any point in the path of a cannon ball through the air, the only forces acting on it are the resistance of the air and the attraction of the earth, the latter having a vertical and downward direction.]

PART I.—STATICS.

CHAPTER I.

STATICS OF A MATERIAL POINT.

16. Composition of Concurrent Forces.—A system of forces acting on a material point is necessarily composed of concurrent forces.

CASE I.—All the forces in **One Plane**. Let O be the material point, the common point of application of all the forces; P_1, P_2 , etc., the given forces, making angles α_1, α_2 , etc., with the axis X . By the parallelogram of forces P may be resolved into and replaced by its components, $P \cos \alpha$, acting along X , and $P \sin \alpha$, along Y .

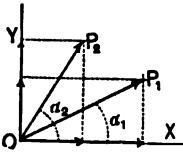

FIG. 4.

Similarly all the remaining forces may be replaced by their X and Y components. We have now a new system, the equivalent of that first given, consisting of a set of X forces, having the same line of application (axis X), and a set of Y forces, all acting in the line Y . The resultant of the X forces being their algebraic sum (denoted by ΣX) (since they have the same line of application) we have

$$\Sigma X = P_1 \cos \alpha_1 + P_2 \cos \alpha_2 + \text{etc.} = \Sigma(P \cos \alpha),$$

and similarly

$$\Sigma Y = P_1 \sin \alpha_1 + P_2 \sin \alpha_2 + \text{etc.} = \Sigma(P \sin \alpha).$$

These two forces, ΣX and ΣY , may be combined by the parallelogram of forces, giving $R = \sqrt{(\Sigma X)^2 + (\Sigma Y)^2}$ as the single resultant of the whole system, and its direction is determined by the angle α ; thus, $\tan \alpha = \frac{\Sigma Y}{\Sigma X}$; see Fig. 5. For equilibrium to exist, R must = 0, which requires, *separately*,

$\Sigma X = 0$, and $\Sigma Y = 0$ (for the two squares $(\Sigma X)^2$ and $(\Sigma Y)^2$ can neither of them be negative quantities).

CASE II.—The forces having any directions in space, but all applied at O , the material point. Let $P_1, P_2,$ etc., be the given forces, P_i making the angles $\alpha_i, \beta_i,$ and $\gamma_i,$ respectively, with three arbitrary axes, $X, Y,$ and Z (Fig. 6), at right angles to each other and intersecting at O , the origin. Similarly let $\alpha_i, \beta_i, \gamma_i,$ be the angles made by P_i with these axes, and so on for all the forces. By the parallelepiped of forces, P_i may be replaced by its components.

$X_i = P_i \cos \alpha_i, Y_i = P_i \cos \beta_i,$ and $Z_i = P_i \cos \gamma_i;$ and

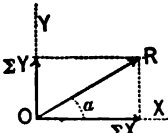

FIG. 5.

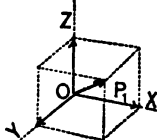

FIG. 6.

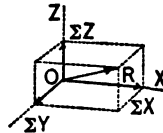

FIG. 7.

similarly for all the forces, so that the entire system is now replaced by the three forces,

$$\begin{aligned} \Sigma X &= P_1 \cos \alpha_1 + P_2 \cos \alpha_2 + \text{etc}; \\ \Sigma Y &= P_1 \cos \beta_1 + P_2 \cos \beta_2 + \text{etc}; \\ \Sigma Z &= P_1 \cos \gamma_1 + P_2 \cos \gamma_2 + \text{etc}; \end{aligned}$$

and finally by the single resultant

$$R = \sqrt{(\Sigma X)^2 + (\Sigma Y)^2 + (\Sigma Z)^2}.$$

Therefore, for equilibrium we must have separately,

$$\Sigma X = 0, \Sigma Y = 0, \text{ and } \Sigma Z = 0.$$

R 's position may be determined by its direction cosines, viz.,

$$\cos \alpha = \frac{\Sigma X}{R}; \cos \beta = \frac{\Sigma Y}{R}; \cos \gamma = \frac{\Sigma Z}{R}.$$

17. Conditions of Equilibrium.—Evidently, in dealing with a system of concurrent forces, it would be a simple matter to

replace any two of the forces by their resultant (diagonal formed on them), then to combine this resultant with a third force, and so on until all the forces had been combined, the last resultant being the resultant of the whole system. The foregoing treatment, however, is useful in showing that for equilibrium of concurrent forces in a plane only two conditions are necessary, viz., $\Sigma X = 0$ and $\Sigma Y = 0$; while in space there are three, $\Sigma X = 0$, $\Sigma Y = 0$, and $\Sigma Z = 0$. In Case I., then, we have conditions enough for determining two unknown quantities; in Case II., three.

18. Problems involving equilibrium of concurrent forces. (A rigid body in equilibrium under no more than three forces may be treated as a material point, since the (two or) three forces are necessarily concurrent.)*

PROBLEM 1.—A body weighing G lbs. rests on a horizontal table: required the pressure between it and the table. Fig. 8. Consider the body free, i.e., conceive all other bodies removed (the table in this instance), being replaced by the forces which they exert on the first body. Taking the axis Y vertical and positive upward, and not assuming in advance either the amount or direction of N , the pressure of the table against the body, but knowing that G , the action of the earth on the body, is vertical and downward, we have

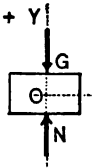

FIG. 8.

here a system of concurrent forces in equilibrium, in which the X and Y components of G are known (being 0 and $-G$ respectively), while those, N_x and N_y , of N are unknown. Putting $\Sigma X = 0$, we have $N_x + 0 = 0$; i.e., N has no horizontal component, $\therefore N$ is vertical. Putting $\Sigma Y = 0$, we have $N_y - G = 0$, $\therefore N_y = +G$; or the vertical component of N , i.e., N itself, is positive (upward in this case), and is numerically equal to G .

PROBLEM 2.—Fig. 9. A body of weight G (lbs.) is moving in a straight line over a rough horizontal table with a uniform velocity v (feet per second) to the right. The tension in an oblique cord by which it is pulled is given, and $= P$ (lbs.),

* Three parallel forces form an exception; see §§ 20, 21, etc.

which remains constant, the cord making a given angle of elevation, α , with the path of the body. Required the vertical pressure N (lbs.) of the table, and also its horizontal action F (friction) (lbs.) against the body.

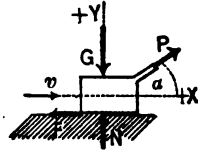

FIG. 9.

Referring by anticipation to Newton's first law of motion, viz., a material point acted on by no force or by balanced forces is either at rest or moving uniformly in a straight line, we see that this problem is a case of balanced forces, i.e., of equilibrium. Since there are only two unknown quantities, N and F , we may determine them by the two equations of Case I., taking the axes X and Y as before. Here let us leave the *direction* of N as well as its amount to be determined by the analysis. As F must evidently point toward the left, treat it as negative in summing the X components; the analysis, therefore, can be expected to give only its numerical value.

$\Sigma X = 0$ gives $P \cos \alpha - F = 0. \quad \therefore F = P \cos \alpha.$
 $\Sigma Y = 0$ gives $N + P \sin \alpha - G = 0. \quad \therefore N = G - P \sin \alpha.$
 $\therefore N$ is upward or downward according as G is $>$ or $<$ $P \sin \alpha$. For N to be a downward pressure upon the body would require the surface of the table to be above it. The ratio of the friction F to the pressure N which produces it can now be obtained, and is called the coefficient of friction. It may vary slightly with the velocity.

This problem may be looked upon as arising from an experiment made to determine the coefficient of friction between the given surfaces at the given uniform velocity.

19. The Free-Body Method.—The foregoing rather labored solutions of very simple problems have been made such to illustrate what may be called the free-body method of treating any problem involving a body acted on by a system of forces. It consists in conceiving the body isolated from all others which act on it in any way, those actions being introduced as so many forces, known or unknown, in amount and position. The system of forces thus formed may be made to yield certain equa-

tions, whose character and number depend on circumstances, such as the behavior of the body, whether the forces are confined to a plane or not, etc., and which are therefore theoretically available for determining an equal number of unknown quantities, whether these be forces, masses, spaces, times, or abstract numbers. Of course in some instances the unknown quantities may enter these equations with such high powers that the elimination may be impossible; but this is a matter of algebra, not of mechanics.

(Addendum to § 49a of page 49.) **Numerical Example.**—A set of light screens is set up at intervals of 100 feet apart in the horizontal path of a cannon-ball, with the object of determining its velocity, and also the rate of change (or negative acceleration) of that velocity, as due to the resistance of the air.

By electrical connection the time of passing each screen is noted, and the *intervals* of time are given in this diagram for four of the screens, *A*, *B*, *C*, and *D*.

.....100'.....100'.....100'.....
...0.0621 sec...	...0.0632 sec...	...0.0648 sec...
<i>A</i> 1 <i>B</i>	2 <i>C</i>	3 <i>D</i>

From these data it is required to compute, as nearly as the circumstances allow, the velocity and acceleration (negative) of the ball at various points (the ball moves from left to right).

Solution.—In passing from *A* to *B* the ball has an *average* velocity of 1610 ft. per second, obtained by dividing the distance of 100 feet by the time of passage, 0.0621 second. Similarly we find the average velocity between *B* and *C* to be 1582 ft. per second, and that between *C* and *D* to be 1554 ft. per second.

As the velocity is not changing very rapidly, we may claim that the ball actually possesses the velocity $v_1 = 1610$ ft. per second at the point 1, midway between *A* and *B*, or very near that point; and similarly the velocity $v_2 = 1582$ ft. per second at point 2, midway between *B* and *C*; and $v_3 = 1554$ ft. per second at point 3, midway between *C* and *D*.

Hence the total gain of velocity from 1 to 2 is $1582 - 1610 = -28$ ft. per second; and the time in which this gain is made is one half of the 0.0621 second plus one half of the 0.0632 second, i.e., 0.0626 second. Therefore an approximate value for the *average* acceleration between points 1 and 2 is found by dividing the -28 ft. per second gain in velocity by the time 0.0626 second occupied in acquiring the gain. This gives -447 ft. per second per second *average* acceleration for portion 1...2 of path, and since screen *B* lies at the middle of this portion, the actual acceleration of the ball's motion as it passes the screen *B* is very nearly equal to this, viz.: -447 ft. per second per second (or "ft. per square second").

By a similar process the student may compute the acceleration at screen *C*. Of course the reason why these results are merely approximate is that the spaces and times concerned, though relatively small, are not infinitesimal.

[A recent English writer calls a unit of velocity a "*speed*;" and a unit of acceleration, a "*hurry*."]

CHAPTER II.

PARALLEL FORCES AND THE CENTRE OF GRAVITY.

20. Preliminary Remarks.—Although by its title this section should be restricted to a treatment of the equilibrium of forces, certain propositions involving the composition and resolution of forces, without reference to the behavior of the body under their action, will be found necessary as preliminary to the principal object in view.

As a rigid body possesses extension in three dimensions, to deal with a system of forces acting on it we require three co-ordinate axes: in other words, the system consists of "forces in space," and in general the forces are *non-concurrent*. In most problems in statics, however, the forces acting are in one plane: we accordingly begin by considering non-concurrent forces in a plane, of which the simplest case is that of two parallel forces. For the present the body on which the forces act will not be shown in the figure, but must be understood to be there (since we have no conception of forces independently of material bodies). The device will frequently be adopted of introducing into the given system two opposite and equal forces acting in the same line: evidently this will not alter the effect of the given system, as regards the rest or motion of the body.

21. Resultant of two Parallel Forces.

CASE I.—The two forces have the *same direction*. Fig. 10. Let P and Q be the given forces, and AB a line perpendicular to them (P and Q are supposed to have been transferred to the intersections A and B).

Put in at A and B two equal and opposite forces S and S' , combining them with P and Q to form P'

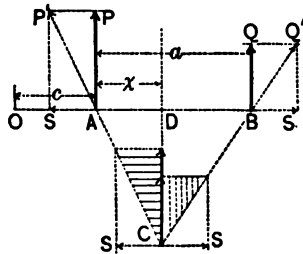

FIG. 10.

and Q' . Transfer P' and Q' to their intersection at C , and there resolve them again into S and P , S and Q . S and S annul each other at C ; therefore P and Q , acting along a common line CD , replace the P and Q first given; i.e., the resultant of the original two forces is a force $R = P + Q$, acting parallel to them through the point D , whose position must now be determined. The triangle CAD is similar to the triangle shaded by lines, $\therefore P : S :: \overline{CD} : x$; and CDB being similar to the triangle shaded by dots, $\therefore S : Q :: a - x : \overline{CD}$. Combining these, we have* $\frac{P}{Q} = \frac{a-x}{x}$ and $\therefore x = \frac{Qa}{P+Q} = \frac{Qa}{R}$. Now write this $Rx = Qa$, and add Rc , i.e., $Pc + Qc$, to each member, c being the distance of O (Fig. 10), any point in AB produced, from A . This will give $R(x+c) = Pc + Q(a+c)$, in which c , $a+c$, and $x+c$ are respectively the lengths of perpendiculars let fall from O upon P , Q , and their resultant R . Any one of these products, such as Pc , is for convenience (since products of this form occur so frequently in Mechanics as a result of algebraic transformation) called the **Moment** of the force about the arbitrary point O . Hence the resultant of two parallel forces of the same direction is equal to their sum, acts in their plane, in a line parallel to them, and at such a distance from any arbitrary point O in their plane as may be determined by writing its moment about O equal to the sum of the moments of the two forces about O . O is called a *centre of moments*, and each of the perpendiculars a *lever-arm*.

CASE II.—Two parallel forces P and Q of opposite directions. Fig. 11. By a process similar to the foregoing, we obtain $R = P - Q$ and $(P - Q)x = Qa$, i.e., $Rx = Qa$. Subtract each member of the last equation from Rc (i.e., $Pc - Qc$), in which c is the distance, from A , of any arbitrary point O in AB produced. This gives $R(c - x) = Pc - Q(a + c)$. But $(c - x)$, c , and $(a + c)$ are respectively the perpendiculars, from

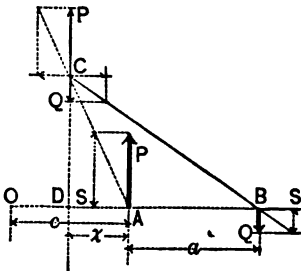

FIG. 11.

* That is, the resultant of two parallel forces pointing in the same direction divides the distance between them in the inverse ratio of those forces.

O , upon R , P , and Q . That is, $R(c - x)$ is the moment of R about O ; Pc , that of P about O ; and $Q(a + c)$, that of Q about O . But the moment of Q is subtracted from that of P , which corresponds with the fact that Q in this figure would produce a rotation about O opposite in direction to that of P . Having in view, then, this imaginary rotation, we may define the moment of a force as *positive* when the indicated direction about the given point is against the hands of a watch; as *negative* when with the hands of a watch.*

Hence, in general, the resultant of any two parallel forces is, in amount, equal to their algebraic sum, acts in a parallel direction in the same plane, while its moment, about any arbitrary point in the plane, is equal to the algebraic sum of the moments of the two forces about the same point.

Corollary.—If each term in the preceding moment equations be multiplied by the secant of an angle (α , Fig. 12) thus:

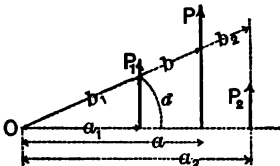

FIG. 12.

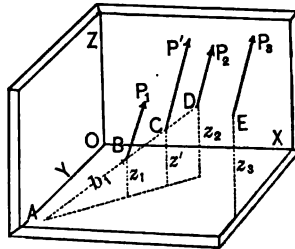

FIG. 13.

(using the notation of Fig. 12), we have $Pa \sec \alpha = P_1 a_1 \sec \alpha + P_2 a_2 \sec \alpha$, i.e., $Pb = P_1 b_1 + P_2 b_2$, in which b , b_1 , and b_2 are the *oblique* distances of the three lines of action from any point O in their plane, and lie on the same straight line; P is the resultant of the parallel forces P_1 and P_2 .

22. Resultant of any System of Parallel Forces in Space.—Let P_1, P_2, P_3 , etc., be the forces of the system, and $x_1, y_1, z_1, x_2, y_2, z_2$, etc., the co-ordinates of their points of application as referred to an arbitrary set of three co-ordinate axes X, Y , and Z , perpendicular to each other. Each force is here re

* These two directions of rotation are often called *counter clockwise*, and *clockwise*, respectively.

restricted to a definite point of application in its line of action (with reference to establishing more directly the fundamental equations for the co-ordinates of the centre of gravity of a body). The resultant P' of any two of the forces, as P_1 and P_2 , is $= P_1 + P_2$, and may be applied at C , the intersection of its own line of action with a line BD joining the points of application of P_1 and P_2 , its components. Produce the latter line to A , where it pierces the plane XY , and let b_1 , b' , and b_2 , respectively, be the distances of B , C , D , from A ; then from the corollary of the last article we have

$$P'b' = P_1b_1 + P_2b_2;$$

but from similar triangles

$$b' : b_1 : l_1 :: z' : z_1 : z_2, \quad \therefore P'z' = P_1z_1 + P_2z_2.$$

Now combine P' , applied at C , with P_3 , applied at E , calling their resultant P'' and its vertical co-ordinate z'' , and we obtain

$$P''z'' = P'z' + P_3z_3, \text{ i.e., } P''z'' = P_1z_1 + P_2z_2 + P_3z_3,$$

also

$$P'' = P' + P_3 = P_1 + P_2 + P_3.$$

Proceeding thus until all the forces have been considered, we shall have finally, for the resultant of the whole system,

$$R = P_1 + P_2 + P_3 + \text{etc.};$$

and for the vertical co-ordinate of its point of application, which we may write \bar{z} ,

$$R\bar{z} = P_1z_1 + P_2z_2 + P_3z_3 + \text{etc.};$$

$$\text{i.e., } \bar{z} = \frac{P_1z_1 + P_2z_2 + P_3z_3 + \dots}{P_1 + P_2 + P_3 + \dots} = \frac{\Sigma(Pz)}{\Sigma P};$$

and similarly for the other co-ordinates.

$$\bar{x} = \frac{\Sigma(Px)}{\Sigma P} \text{ and } \bar{y} = \frac{\Sigma(Py)}{\Sigma P}.$$

In these equations, in the general case, such products as P_1z_1 , etc., cannot strictly be called moments. The point whose co-

ordinates are the \bar{x} , \bar{y} , and \bar{z} , just obtained, is called the *Centre of Parallel Forces*, and its position is *independent of the (common) direction* of the forces concerned.

Example.—If the parallel forces are contained in one plane, and the axis Y be assumed parallel to the direction of the forces, then each product like $P_i x_i$ will be a *moment*, as defined in § 21; and it will be noticed in the accompanying numerical example, Fig. 14, that a detailed substitution in the equation

$$\bar{R}x = P_1 x_1 + P_2 x_2 + \text{etc.}, \dots (1)$$

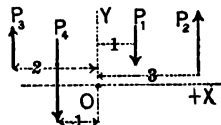

FIG. 14.

having regard to the proper sign of each force and of each abscissa, gives the same result as if each product Px were first obtained numerically, and a sign affixed to the product considered as a moment about the point O . Let $P_1 = -1$ lb.; $P_2 = +2$ lbs.; $P_3 = +3$ lbs.; $P_4 = -6$ lbs.; $x_1 = +1$ ft.; $x_2 = +3$ ft.; $x_3 = -2$ ft.; and $x_4 = -1$ ft. Required the amount and position of the resultant R . In amount $R = \Sigma P = -1 + 2 + 3 - 6 = -2$ lbs.; i.e., it is a *downward* force of 2 lbs. As to its position, $R\bar{x} = \Sigma(Px)$ gives $(-2)\bar{x} = (-1) \times (+1) + 2 \times 3 + 3 \times (-2) + (-6) \times (-1) = -1 + 6 - 6 + 6$. Now from the figure, by inspection, it is evident that the moment of P_1 about O is negative (*with the hands of a watch*), and is numerically = 1, i.e., its moment = -1 ; similarly, by inspection, that of P_2 is seen to be positive, that of P_3 negative, that of P_4 positive; which agree with the results just found, that $(-2)\bar{x} = -1 + 6 - 6 + 6 = +5$ ft. lbs. (Since a moment is a product of a force (lbs.) by a length (ft.), it may be called so many foot-pounds.) Next, solving for \bar{x} , we obtain $\bar{x} = (+5) \div (-2) = -2.5$ ft.; i.e., the resultant of the given forces is a downward force of 2 lbs. acting in a vertical line 2.5 ft. to the left of the origin. Hence, if the body in question be a horizontal rod whose weight has been already included in the statement of forces, a support placed 2.5 ft. to the left of O and capable of resisting at least 2 lbs. downward pressure will preserve equilibrium; and the pressure which it exerts

against the rod must be an upward force, P_4 , of 2 lbs., i.e. equal and opposite of the resultant of P_1, P_2, P_3, P_4 .

Fig. 15 shows the rod as a free body in equilibrium under the five forces. $P_4 = + 2$ lbs. = the reaction of the support.

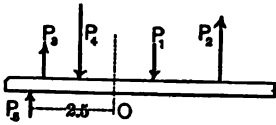

FIG. 15.

Of course P_4 is one of a pair of equal and opposite forces; the other one is the pressure of the rod against the support, and would take its place among the forces acting on the support.

23. Centre of Gravity.—Among the forces acting on any rigid body at the surface of the earth is the so-called attraction of the latter (i.e., gravitation), as shown by a spring-balance, which indicates the *weight* of the body hung upon it. The weights of the different particles of any rigid body constitute a system of parallel forces (practically so, though actually slightly convergent). The point of application of the resultant of these forces is called the *centre of gravity* of the body, and may also be considered the *centre of mass*, the body being of very small dimensions compared with the earth's radius.

If \bar{x} , \bar{y} , and \bar{z} denote the co-ordinates of the centre of gravity of a body referred to three co-ordinate axes, the equations derived for them in § 22 are directly applicable, with slight changes in notation.

Denote the weight of any particle of the body by dG , its volume by dV , by γ its *heaviness* (rate of weight, see § 7) and its co-ordinates by x, y , and z ; then, using the integral sign as indicating a summation of like terms for all the particles of the body, we have, for heterogeneous bodies,

$$\bar{x} = \frac{\int \gamma x dV}{\int \gamma dV}; \quad \bar{y} = \frac{\int \gamma y dV}{\int \gamma dV}; \quad \bar{z} = \frac{\int \gamma z dV}{\int \gamma dV}; \quad \dots \quad (1)$$

while, if the body is homogeneous, γ is the same for all its elements, and being therefore placed outside the sign of summation, is cancelled out, leaving for *homogeneous* bodies (V denoting the total volume)

$$\bar{x} = \frac{\int x dV}{V}; \quad \bar{y} = \frac{\int y dV}{V}; \quad \text{and} \quad \bar{z} = \frac{\int z dV}{V} \dots \quad (2)$$

PARALLEL FORCES AND THE CENTRE OF GRAVITY. 19

Corollary.—It is also evident that if a homogeneous body is for convenience considered as made up of several finite parts, whose volumes are $V_1, V_2,$ etc., and whose gravity co-ordinates are $\bar{x}_1, \bar{y}_1, \bar{z}_1; \bar{x}_2, \bar{y}_2, \bar{z}_2;$ etc., we may write

$$\bar{x} = \frac{V_1\bar{x}_1 + V_2\bar{x}_2 + \dots}{V_1 + V_2 + \dots} \dots \dots \dots (3)$$

If the body is heterogeneous, put G_i (weights), etc., instead of V_i , etc., in equation (3).

If the body is an infinitely thin *homogeneous shell* of uniform thickness = h , then $dV = h dF$ (dF denoting an element, and F the whole area of one surface) and equations (2) become, after cancellation,

$$\bar{x} = \frac{\int x dF}{F}; \quad \bar{y} = \frac{\int y dF}{F}; \quad \bar{z} = \frac{\int z dF}{F} \dots \dots \dots (4)$$

Similarly, for a *homogeneous wire* of constant small cross-section (i.e., a geometrical line, having weight), its length being s , and an element of length ds , we obtain

$$\bar{x} = \frac{\int x ds}{s}; \quad \bar{y} = \frac{\int y ds}{s}; \quad \bar{z} = \frac{\int z ds}{s} \dots \dots \dots (5)$$

It is often convenient to find the centre of gravity of a thin plate by experiment, balancing it on a needle-point; other shapes are not so easily dealt with.

24. Symmetry.—Considerations of symmetry of form often determine the centre of gravity of homogeneous solids without analysis, or limit it to a certain line or plane. Thus the centre of gravity of a sphere, or any regular polyedron, is at its centre of figure; of a right cylinder, in the middle of its axis; of a thin plate of the form of a circle or regular polygon, in the centre of figure; of a straight wire of uniform cross-section, in the middle of its length.

Again, if a homogeneous body is symmetrical about a plane, the centre of gravity must lie in that plane, called a plane of

gravity; if about a line, in that line called a line of gravity; if about a point, in that point.

25. By considering certain modes of subdivision of a homogeneous body, lines or planes of gravity are often made apparent. E.g., a line joining the middle of the bases of a trapezoidal plate is a line of gravity, since it bisects all the strips of uniform width determined by drawing parallels to the bases; similarly, a line joining the apex of a triangular plate to the middle of the opposite side is a line of gravity. Other cases can easily be suggested by the student.

26. Problems.—(1) Required the position of the centre of gravity of a *fine homogeneous wire of the form of a circular arc, AB*, Fig. 16. Take the origin O at the centre of the circle, and the axis X bisecting the wire. Let the length of the wire, s , $= 2s$; ds = element of arc. We need determine only the \bar{x} , since evidently $\bar{y} = 0$. Equations (5), § 23, are applicable here, i.e., $\bar{x} = \frac{\int x ds}{s}$.

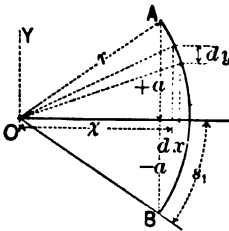

FIG. 16.

From similar triangles we have

$$ds : dy :: r : x; \therefore ds = \frac{r dy}{x};$$

$$\therefore \bar{x} = \frac{r}{2s} \int_{y=-a}^{y=+a} dy = \frac{2ra}{2s}, \text{ i.e., } = \text{chord} \times \text{radius} \div \text{length of}$$

wire. For a semicircular wire, this reduces to $\bar{x} = 2r \div \pi$.

PROBLEM 2. *Centre of gravity of trapezoidal (and triangular) thin plates, homogeneous, etc.*—Prolong the non-parallel sides of the trapezoid to intersect at O , which take as an origin, making the axis X perpendicular to the bases b and b_1 . We may here use equations (4), § 23, and may take a vertical strip for our element of area, dF , in determining \bar{x} ; for each point of such a strip has the same x . Now $dF = (y + y')dx$, and

from similar triangles $y + y' = \frac{b}{h} x$. Now $F_1 = \frac{1}{2}(bh - b_1h_1)$,

can be written $\frac{1}{2} \frac{b}{h} (h^2 - h_1^2)$, and $\bar{x} = \frac{\int x dF}{F}$ becomes

$$= \left[\frac{b}{h} \int_{h_1}^h x^2 dx \right] \div \frac{1}{2} \frac{b}{h} (h^2 - h_1^2) = \frac{2}{3} \frac{h^3 - h_1^3}{h^2 - h_1^2}$$

for the trapezoid.

For a triangle $h_1 = 0$, and we have $\bar{x} = \frac{2}{3} h$; that is, the centre of gravity of a triangle is one third the altitude from the base. The centre of gravity is finally determined by knowing

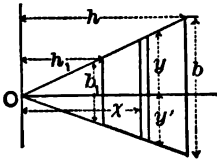

FIG. 17.

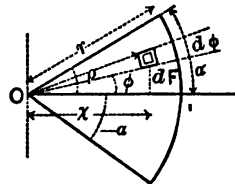

FIG. 18.

that a line joining the middles of b and b_1 is a line of gravity; or joining O and the middle of b in the case of a triangle.

PROBLEM 3. *Sector of a circle. Thin plate, etc.*—Let the notation, axes, etc., be as in Fig. 18. Angle of sector = 2α ; $\bar{x} = ?$ Using polar co-ordinates, the element of area dF (a small rectangle) = $\rho d\phi \cdot d\rho$, and its $x = \rho \cos \phi$; hence the total area =

$$F = \int_{-\alpha}^{+\alpha} \left[\int_0^r \rho d\rho \right] d\phi = \int_{-\alpha}^{+\alpha} \frac{1}{2} r^2 d\phi = \frac{r^2}{2} \left[\phi \right]_{-\alpha}^{+\alpha};$$

i.e., $F = r^2 \alpha$. From equations (4), § 23, we have

$$\bar{x} = \frac{1}{F} \int x dF$$

$$= \frac{1}{F} \int \int \cos \phi \rho^2 d\rho d\phi = \frac{1}{F} \int_{-\alpha}^{+\alpha} \left[\cos \phi \int_0^r \rho^2 d\rho \right] d\phi.$$

(*Note on double integration.*—The quantity

$$\left[\cos \varphi \int_0^r \rho^2 d\rho \right] d\varphi,$$

is that portion of the summation $\iint \cos \varphi \rho^2 d\rho d\varphi$ which belongs to a single elementary sector (triangle), since all its elements (rectangles), from centre to circumference, have the same φ and $d\varphi$.)

That is,

$$\bar{x} = \frac{1}{F} \cdot \frac{r^3}{3} \int_{-\alpha}^{+\alpha} \cos \varphi d\varphi = \frac{r^3}{3r^2\alpha} \left[\sin \varphi \right]_{-\alpha}^{+\alpha} = \frac{2}{3} \cdot \frac{r \sin \alpha}{\alpha};$$

or, putting $\beta = 2\alpha =$ total angle of sector, $\bar{x} = \frac{4}{3} \frac{r \sin \frac{1}{2}\beta}{\beta}$.

For a semicircular plate this reduces to $\bar{x} = \frac{4r}{3\pi}$.

[*Note.*—In numerical substitution the arcs α and β used above (unless sin or cos is prefixed) are understood to be expressed in circular measure (π -measure); e.g., for a quadrant, $\beta = \frac{\pi}{2} = 1.5707+$; for 30° , $\beta = \frac{\pi}{6}$; or, in general, if β

in degrees $= \frac{180^\circ}{n}$, then β in π -measure $= \frac{\pi}{n}$.]

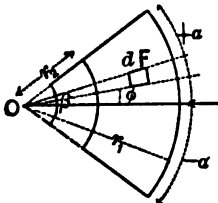

FIG. 19.

PROBLEM 4. *Sector of a flat ring; thin plate, etc.*—Treatment similar to that of Problem 3, the difference being that the

limits of the interior integrations are $\left[\begin{matrix} r_1 \\ r_2 \end{matrix} \right.$

instead of $\left[\begin{matrix} r \\ 0 \end{matrix} \right.$ Result,

$$\bar{x} = \frac{4}{3} \cdot \frac{r_1^3 - r_2^3}{r_1^2 - r_2^2} \cdot \frac{\sin \frac{1}{2}\beta}{\beta}.$$

PROBLEM 5.—*Segment of a circle; thin plate, etc.*—Fig. 20. Since each rectangular element of any vertical strip has the same x , we may take the strip as dF in finding \bar{x} , and use y as the half-height of the strip. $dF = 2ydx$, and from similar triangles $x : y :: (-dy) : dx$, i.e., $x dy = -y dx$. Hence from eq. (4), § 23,

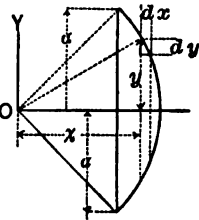

FIG. 20.

$$\bar{x} = \frac{\int x dF}{F} = \frac{\int x 2y dx}{F} = \frac{-2 \int_a^0 y^2 dy}{F} = \frac{2}{3F} \left[\frac{2}{3} - y^3 \right] = \frac{2}{3} \cdot \frac{a^3}{F^2}$$

but $a =$ the half-chord, hence, finally, $\bar{x} = \frac{(\text{chord})^2}{12F}$.

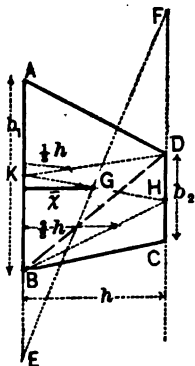

FIG. 21.

PROBLEM 6.—*Trapezoid; thin plate, etc.*, by the method in the corollary of § 23; equations (3). Required the distance \bar{x} from the base AB . Join DB , thus dividing the trapezoid $ABCD$ into two triangles $ADB = F_1$ and $DBC = F_2$, whose gravity \bar{x} 's are, respectively, $\bar{x}_1 = \frac{1}{3}h$ and $\bar{x}_2 = \frac{2}{3}h$. Also, $F_1 = \frac{1}{2}hb_1$, $F_2 = \frac{1}{2}hb_2$, and F (area of trapezoid) $= \frac{1}{2}h(b_1 + b_2)$. Eq. (3) of § 23 gives $F\bar{x} = F_1\bar{x}_1 + F_2\bar{x}_2$; hence, substituting, $(b_1 + b_2)\bar{x} = \frac{1}{3}b_1h + \frac{2}{3}b_2h$.

$$\therefore \bar{x} = \frac{h}{3} \cdot \frac{(b_1 + 2b_2)}{b_1 + b_2}$$

The line joining the middles of b_1 and b_2 is a line of gravity, and is divided in such a ratio by the centre of gravity that the following construction for finding the latter holds good: Prolong each base, in opposite directions, an amount equal to the other base; join the two points thus found: the intersection with the other line of gravity is the centre of gravity of the trapezoid. Thus, Fig. 21, with $BE = b_2$ and $DF = b_1$, join FE , etc.

PROBLEM 7. Homogeneous oblique cone or pyramid.—Take the origin at the vertex, and the axis X perpendicular to the base (or bases, if a frustum). In finding \bar{x} we may put dV = volume of any lamina parallel to YZ , F being the base of such a lamina, each point of the lamina having the same x . Hence, (equations (2), § 23),

$$\bar{x} = \frac{1}{V} \int x dV, \quad V = \int dV = \int F dx;$$

but

$$F : F_2 :: x^2 : h_2^2, \quad \therefore F = \frac{F_2}{h_2^2} x^2,$$

and

$$V = \frac{F_2}{h_2^2} \int x^2 dx = \frac{F_2}{h_2^2} \left[\frac{x^3}{3} \right]; \quad \int x dV = \frac{F_2}{h_2^2} \int x^3 dx = \frac{F_2}{h_2^2} \left[\frac{x^4}{4} \right].$$

For a frustum, $\bar{x} = \frac{3}{4} \cdot \frac{h_2^4 - h_1^4}{h_2^2 - h_1^2}$; while for a pyramid, h_1 , being = 0, $\bar{x} = \frac{3}{4} h$. Hence the centre of gravity of a pyramid

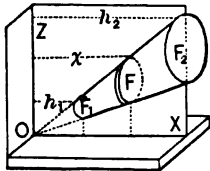

is one fourth the altitude from the base. It also lies in the line joining the vertex to the centre of gravity of the base.

PROBLEM 8.—If the heaviness of the material of the above cone or pyramid varied directly as x , γ , being its heaviness at the base F_2 , we would use equations (1), § 23,

putting $\gamma = \frac{\gamma_2}{h_2} x$; and finally, for the frustum,

$$\bar{x} = \frac{4}{5} \cdot \frac{h_2^5 - h_1^5}{h_2^2 - h_1^2},$$

and for a complete cone $\bar{x} = \frac{4}{5} h_2$.

27. The Centrobaric Method.—If an elementary area dF be revolved about an axis in its plane, through an angle $\alpha < 2\pi$.

the distance from the axis being = x , the volume generated is $dV = \alpha x dF$, and the total volume generated by all the dF 's of a finite plane figure whose plane contains the axis and which lies entirely on one side of the axis, will be $V = \int dV = \int \alpha x dF$. But from § 23, $\int \alpha x dF = \alpha F \bar{x}$; \bar{x} being the length of path described by the centre of gravity of the plane figure, we may write: *The volume of a solid of revolution generated by a plane figure, lying on one side of the axis, equals the area of the figure multiplied by the length of curve described by the centre of gravity of the figure.*

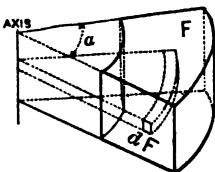

FIG. 23.

A corresponding statement may be made for the surface generated by the revolution of a line. The arc α must be expressed in π measure in numerical work.

27a. Centre of Gravity of any Quadrilateral.—Fig. 23a.

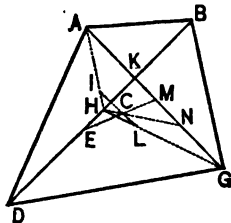

FIG. 23a.

Construction; $ABGD$ being any quadrilateral. Draw the diagonals. On the long segment DK of DB lay off $DE = BK$, the shorter, to determine E ; similarly, determine N on the other diagonal, by making $GN = AK$. Bisect EK in H and KN in M . The intersection of EM and NH is the centre of gravity, C .

Proof.— H being the middle of DB , and AH and HG having been joined, I the centre of gravity of the triangle ABD is found on AH , by making $HI = \frac{1}{3}AH$; similarly, by making $HL = \frac{1}{3}HG$, L is the centre of gravity of triangle BDG . $\therefore IL$ is parallel to AG and is a gravity-line of the whole figure; and the centre of gravity C may be found on it if we can make $CL : CI :: \text{area } ABD : \text{area } BDG$ (§ 21). But since these triangles have a common base DB , their areas are proportional to the slant heights (equally inclined to DB) AK and KG , i.e., to GN and NA . Hence HN , which divides IL in the required ratio, contains C , and is \therefore a gravity-line. By similar reasoning, using the other diagonal, AG , and

the two triangles into which it divides the whole figure, we may prove EM to be a gravity-line also. Hence the construction is proved.

27b. EXAMPLES.—1. Required the volume of a sphere by the centrobaric method.

A sphere may be generated by a semicircle revolving about its diameter through an arc $\alpha = 2\pi$. The length of the path described by its centre of gravity is $= 2\pi \frac{4r}{3\pi}$ (see Prob. 3, § 26), while the area of the semicircle is $\frac{1}{2}\pi r^2$. Hence by § 27,

$$\text{Volume generated} = 2\pi \cdot \frac{4r}{3\pi} \cdot \frac{1}{2}\pi r^2 = \frac{4}{3}\pi r^3.$$

2. Required the position of the centre of gravity of the sector of a flat ring in which $r_1 = 21$ feet, $r_2 = 20$ feet, and $\beta = 80^\circ$ (see Fig. 19, and § 26, Prob. 4).

$\sin \frac{\beta}{2} = \sin 40^\circ = 0.64279$, and β in *circular measure* = $\frac{80}{180}\pi = \frac{4}{9}\pi = 1.3962$. By using r_1 and r_2 in feet, \bar{x} will be obtained in feet.

$$\therefore \bar{x} = \frac{4}{3} \cdot \frac{r_1^3 - r_2^3}{r_1^2 - r_2^2} \cdot \frac{\sin \frac{\beta}{2}}{\beta} = \frac{4}{3} \cdot \frac{1261}{41} \cdot \frac{0.64279}{1.3962} = 18.87 \text{ feet.}$$

CHAPTER III.

STATICS OF A RIGID BODY.

28. Couple.—On account of the peculiar properties and utility of a system of two equal forces acting in parallel lines and in opposite directions, it is specially considered, and called a **Couple**. The *arm* of a couple is the perpendicular distance between the forces; its *moment*, the product of this arm, by one of the forces. The axis of a couple is an imaginary line drawn perpendicular to its plane on that side from which the rotation appears *positive* (against the hands of a watch). (An ideal rotation is meant, suggested by the position of the arrows; any actual rotation of the rigid body is a subject for future consideration.) In dealing with two or more couples the lengths of their axes are made proportional to their moments; in fact, by selecting a proper scale, numerically equal to these moments. E.g., in Fig. 24, the moments of the two couples there shown are Pa and Qb ; their axes p and q so laid off that $Pa : Qb :: p : q$, and that the ideal rotation may appear positive, viewed from the outer end of the axis.

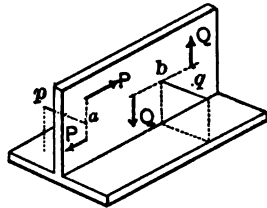

FIG. 24.

29. No single force can balance a couple.—For suppose the couple P, P , could be balanced by a force R' , then this, acting at some point C , ought to hold the couple in equilibrium. Draw CO through O , the centre of symmetry of the couple, and make $OD = OC$. At D put in two opposite and equal forces, S and T , equal and parallel to R' . The supposed equilibrium is undisturbed. But if R', P , and

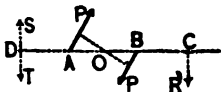

FIG. 25.

P are in equilibrium, so ought (by symmetry about O) S , P , and P to be in equilibrium, and they may be removed without disturbing equilibrium. But we have left T and R' , which are evidently not in equilibrium; \therefore the proposition is proved by this *reductio ad absurdum*. Conversely a couple has no single resultant.

30. A couple may be transferred anywhere in its own plane.

—First, it may be turned through any angle α , about any point of its arm, or of its arm produced. Let (P, P') be a couple, G any point of its arm (produced), and α any angle. Make $GC = GA$, $CD = AB$, and put in at C , P_1 and P_2 equal to P (or P'), opposite to each other and perpendicular to GC ; and P_3 and P_4 similarly at D . Now apply and combine P and P_1 at O , P' and P_3 at O' ; then evidently R and R' neutralize each other, leaving P_2 and P_4 equivalent to the original couple (P, P') . The arm $\overline{CD} = \overline{AB}$. Secondly, if G be at infinity, and $\alpha = 0$, the same proof applies, i.e., a couple may be moved parallel to itself in its own plane. Therefore, by a combination of the two transferrals, the proposition is established for any transferral in the plane.

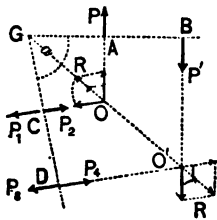

FIG. 26.

31. A couple may be replaced by another of equal moment in a parallel plane.—Let (P, P') be a couple. Let CD , in a parallel plane, be parallel to AB . At D put in a pair of equal and opposite forces, S_1 and S_2 , parallel to P and each $= \frac{\overline{AE}}{\overline{ED}}P$. Similarly at C , S_3 and S_4 , parallel to P and each $= \frac{\overline{BE}}{\overline{EC}}P$.

But, from similar triangles,

$$\frac{AE}{ED} = \frac{BE}{EC}; \therefore S_1 = S_2 = S_3 = S_4.$$

[NOTE.—The above values are so chosen that the intersection point E may be the point of application of $(P + S_2)$, the resultant of P and S_2 ; and also of $(P' + S_1)$, the resultant of P' and S_1 , as follows from § 21; thus (Fig. 28), R , the resultant of the two parallel forces P and S_2 , is $P + S_2$, and its moment about any centre of moments, as E , its own point of application, should equal the (algebraic) sum of the moments of its components about E ; i.e., $R \times \text{zero} = P \cdot \overline{AE} - S_2 \cdot \overline{DE}$; $\therefore S_2 = \frac{AE}{DE} \cdot P$.]

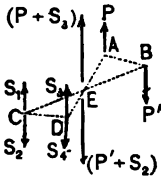

FIG. 27.

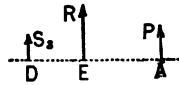

FIG. 28.

Replacing P' and S_1 by $(P' + S_1)$, and P and S_2 by $(P + S_2)$, the latter resultants cancel each other at E , leaving the couple (S_1, S_2) with an arm CD , equivalent to the original couple P, P' with an arm AB . But, since $S_1 = \frac{BE}{EC} \cdot P = \frac{AB}{CD} \cdot P$, we have $S_1 \times \overline{CD} = P \times \overline{AB}$; that is, their moments are equal.

32. Transferral and Transformation of Couples.—In view of the foregoing, we may state, in general, that a couple acting on a rigid body may be transferred to any position in any parallel plane, and may have the values of its forces and arm changed in any way so long as its moment is kept unchanged, and still have the same effect on the rigid body (as to rest or motion, not in distorting it).

Corollaries.—A couple may be replaced by another in any position so long as their axes are equal and parallel and similarly situated with respect to their planes.

A couple can be balanced only by another couple whose axis is equal and parallel to that of the first, and dissimilarly situated. For example, Fig. 29, Pa being $= Qb$, the rigid body AB (here supposed without weight) is in equilibrium in each

case shown. By "reduction of a couple to a certain arm a " is meant that for the original couple whose arm is a' , with forces each = P' , a new couple is substituted whose arm shall be = a , and the value of whose forces P and P must be computed from the condition

$$Pa = P'a', \quad \text{i.e.,} \quad P = P'a' \div a.$$

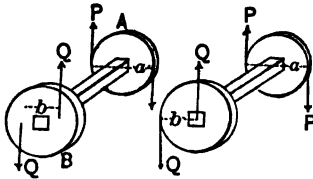

FIG. 29.

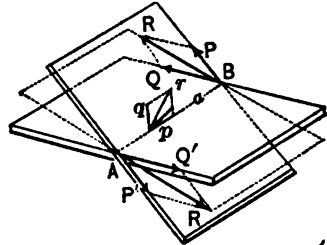

FIG. 30.

33. Composition of Couples.—Let (P, P') and (Q, Q') be two couples in different planes *reduced to the same arm* $\overline{AB} = a$, which is a portion of the line of intersection of their planes. That is, whatever the original values of the individual forces and arms of the two couples were, they have been transferred and replaced in accordance with § 32, so that $P \cdot \overline{AB}$, the moment of the first couple, and the direction of its axis, p , have remained unchanged; similarly for the other couple. Combining P with Q and P' with Q' , we have a resultant couple (R, R') whose arm is also \overline{AB} . The axes p and q of the component couples are proportional to $P \cdot \overline{AB}$ and $Q \cdot \overline{AB}$, i.e., to P and Q , and contain the same angle as P and Q . Therefore the parallelogram $p \dots q$ is similar to the parallelogram $P \dots Q$; whence $p : q :: P : Q$, or $p : q : r :: Pa : Qa : Ra$. Also r is evidently perpendicular to the plane of the resultant couple (R, R') , whose moment is Ra . Hence r , the diagonal of the parallelogram on p and q , is the axis of the resultant couple. To combine two couples, therefore, we have only to combine their axes, as if they were forces, by a parallelogram, the diagonal being the axis of the resultant couple; the plane of this couple will be perpendicular to the

axis just found, and its moment bears the same relation to the moments of the component couples as the diagonal axis to the two component axes. Thus, if two couples, of moments Pa and Qb , lie in planes perpendicular to each other, their resultant couple has a moment $Rc = \sqrt{(Pa)^2 + (Qb)^2}$.

If three couples in different planes are to be combined, the axis of their resultant couple is the diagonal of the parallelepiped formed on the axes, laid off to the same scale and *pointing in the proper directions*, the proper *direction* of an axis being *away* from the plane of its couple, on the side from which the couple appears of positive rotation.

34. If several couples lie in the same plane their axes are parallel and the axis of the resultant couple is their algebraic sum; and a similar relation holds for the moments: thus, in Fig. 24, the resultant of the two couples has a moment = $Qb - Pa$, which shows us that a convenient way of combining couples, when all in one plane, is to call the moments positive or negative, according as the ideal rotations are against, or with, the hands of a watch, as seen from the *same* side of the plane; the sign of the algebraic sum will then show the ideal rotation of the resultant couple.

35. **Composition of Non-concurrent Forces in a Plane.**—Let P_1, P_2 , etc., be the forces of the system; x_1, y_1, x_2, y_2 , etc., the

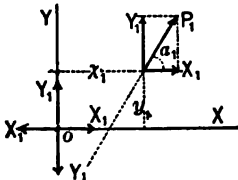

FIG. 31.

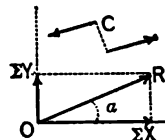

FIG. 32.

co-ordinates of their points of application; and α, α_2, \dots etc., their angles with the axis X . Replace P_1 by its components X_1 and Y_1 , parallel to the arbitrary axes of reference. At the origin put in two forces, opposite to each other and equal and parallel to X_1 ; similarly for Y_1 . (Of course $X_1 = P_1 \cos \alpha$ and $Y_1 = P_1 \sin \alpha$.) We now have P_1 replaced by two forces X_1 ,

and Y_1 at the origin, and two couples, in the same plane, whose moments are respectively $-X_1y_1$ and $+Y_1x_1$, and are therefore (§ 34) equivalent to a single couple, in the same plane with a moment $= (Y_1x_1 - X_1y_1)$.

Treating all the remaining forces in the same way, the whole system of forces is replaced by

the force $\Sigma(X) = X_1 + X_2 + \dots$ at the origin, along the axis X ;
 the force $\Sigma(Y) = Y_1 + Y_2 + \dots$ at the origin, along the axis Y ;
 and the couple whose mom. $G = \Sigma(Yx - Xy)$, which may be called the couple C (see Fig. 32), and may be placed anywhere in the plane. Now $\Sigma(X)$ and $\Sigma(Y)$ may be combined into a force R ; i.e.,

$$R = \sqrt{(\Sigma X)^2 + (\Sigma Y)^2} \text{ and its direction-cosine is } \cos \alpha = \frac{\Sigma X}{R}.$$

Since, then, the whole system reduces to C and R , we must have for equilibrium $R = 0$, and $G = 0$; i.e., for equilibrium $\Sigma X = 0$, $\Sigma Y = 0$, and $\Sigma(Yx - Xy) = 0$. . eq. (1)

If R alone $= 0$, the system reduces to a couple whose moment is $G = \Sigma(Yx - Xy)$; and if G alone $= 0$ the system reduces to a single force R , applied at the origin. If, in general, neither R nor $G = 0$, the system is still equivalent to a single force, but not applied at the origin (as could hardly be expected, since the origin is arbitrary); as follows (see Fig. 33):

Replace the couple C by one of equal moment, G , with each force $= R$. Its arm will therefore be $\frac{G}{R}$. Move this couple in the plane so that one of its forces R may cancel the R already at the origin, thus leaving a **single resultant** R for the whole system, applied in a line at a perpendicular distance, $c = \frac{G}{R}$, from the origin, and making an angle α whose cosine $= \frac{\Sigma X}{R}$, with the axis X .

36. More convenient form for the equations of equilibrium of non-concurrent forces in a plane.—In (I.), Fig. 34, O being

any point and a its perpendicular distance from a force P ; put in at O two equal and opposite forces P and $P' =$ and \parallel to P , and we have P replaced by an equal single force P' at O , and a couple whose moment is $+ Pa$. (II.) shows a similar construction, dealing with the X and Y components of P , so that in (II.) P is replaced by single forces X' and Y' at O

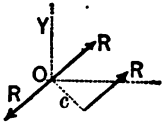

FIG. 33.

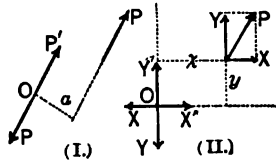

FIG. 34.

(and they are equivalent to a resultant P' , at O , as in (I.), and two couples whose moments are $+ Yx$ and $- Xy$.)

Hence, O being the same point in both cases, the couple Pa is equivalent to the two last mentioned, and, their axes being parallel, we must have $Pa = Yx - Xy$. Equations (1), § 35, for equilibrium, may now be written

$$\Sigma X = 0, \Sigma Y = 0, \text{ and } \Sigma(Pa) = 0. \quad (2)$$

In problems involving the equilibrium of non-concurrent forces in a plane, we have *three independent conditions, or equations*, and can determine at most three unknown quantities. For practical solution, then, the rigid body having been made *free* (by conceiving the actions of all other bodies as represented by forces), and being in equilibrium (which it must be if at rest), we apply equations (2) literally; i.e., assuming an origin and two axes, equate the sum of the X components of all the forces to zero; similarly for the Y components; and then for the "moment-equation," having dropped a perpendicular from the origin upon each force, write the algebraic sum of the products (*moments*) obtained by multiplying each force by its perpendicular, or "*lever-arm*," equal to zero, calling each product $+$ or $-$ according as the ideal rotation appears against, or with, the hands of a watch, as seen from the same side of the plane. (The converse convention would do as well.)

Sometimes it is convenient to use three moment equations, taking a new origin each time, and then the $\Sigma X = 0$ and $\Sigma Y = 0$ are superfluous, as they would not be independent equations.

37. Problems involving Non-concurrent Forces in a Plane.—

Remarks. The weight of a rigid body is a vertical force through its centre of gravity, downwards.

If the surface of contact of two bodies is *smooth* the action (pressure, or force) of one on the other is perpendicular to the surface at the point of contact. If a cord must be imagined cut, to make a body free, its tension must be inserted in the line of the cord, and in such a direction as to keep *taut* the small portion still fastened to the body. In case the pin of a hinge must be removed, to make the body free, its pressure against the ring being unknown in *direction* and *amount*, it is most convenient to represent it by its unknown components X and Y , in *known* directions. In the following problems there is supposed to be no friction. If the line of action of an unknown force is known, but not its direction (forward or backward), assume a direction for it and adhere to it in all the three equations, and if the assumption is correct the value of the force, after elimination, will be positive; if incorrect, negative.

Problem 1.—Fig. 35. Given an oblique rigid rod, with two loads G_1 (its own weight) and G_2 ; required the reaction of the *smooth* vertical wall at A , and the direction and amount of the

hinge-pressure at O . The reaction at A must be horizontal; call it X' . The pressure at O , being unknown in direction, will have both its X and Y components unknown. The three unknowns, then, are X_0 , X' , and Y_0 , while G_1 , G_2 , a_1 , a_2 , and h are known. The figure shows the rod as a *free body*, all the forces acting on it

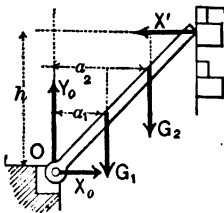

FIG. 35.

have been put in, and, since the rod is at rest, constitute a system of non-concurrent forces in a plane, ready for the conditions of equilibrium. Taking origin and axes as in the figure.

$\Sigma X = 0$ gives $+X_0 - X' = 0$; $\Sigma Y = 0$ gives $+Y_0 - G_1 - G_2 = 0$; while $\Sigma(Pa) = 0$, about O , gives $+X'h - G_1a_1 - G_2a_2 = 0$. (The moments of X_0 and Y_0 about O are, each, = zero.) By elimination we obtain $Y_0 = G_1 + G_2$; $X_0 = X' = [G_1a_1 + G_2a_2] \div h$; while the pressure at $O = \sqrt{X_0^2 + Y_0^2}$, and makes with the horizontal an angle whose $\tan = Y_0 \div X_0$.

[N.B. A special solution for this problem consists in this, that the resultant of the two known forces G_1 and G_2 intersects the line of X' in a point which is easily found by § 21. The hinge-pressure must pass through this point, since three forces in equilibrium must be concurrent.]

We might vary this problem by limiting X' to a safe value, depending on the stability of the wall, and making h an unknown. The three unknowns would then be X_0 , Y_0 , and h .

Problem 2.—Given two rods with loads, three hinges (or “pin-joints”), and all dimensions: required the three hinge-

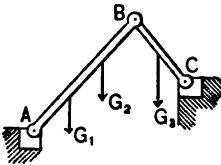

FIG. 36.

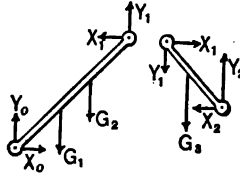

FIG. 37.

pressures; i.e., there are six unknowns, viz., three X and three Y components. We obtain three equations from each of the two free bodies in Fig. 37. The student may fill out the details. Notice the application of the principle of action and reaction at B (see § 3).

Problem 3.—A Warren bridge-truss rests on the horizontal smooth abutment-surfaces in Fig. 38. It is composed of equal isosceles triangles; no piece is continuous beyond a joint, each of which is a pin connection. All loads are considered as acting at the joints, so that each piece will be subjected to a simple tension or compression.

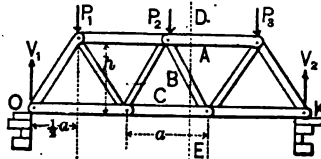

FIG. 38.

First, required the reactions of the supports V_1 and V_2 ; these and the loads are called the *external forces*. $\Sigma(Pa)$ about $O = 0$ gives (the whole truss is the free body)

$$V_2 3a - P_1 \cdot \frac{1}{2}a - P_2 \cdot \frac{2}{3}a - P_3 \cdot \frac{1}{3}a = 0;$$

while $\Sigma(Pa)$ about $K = 0$ gives

$$- V_1 \cdot 3a + P_1 \cdot \frac{1}{2}a + P_2 \cdot \frac{2}{3}a + P_3 \cdot \frac{1}{3}a = 0;$$

$$\therefore V_1 = \frac{1}{3}[5P_1 + 3P_2 + P_3];$$

$$\text{and } V_2 = \frac{1}{3}[P_1 + 3P_2 + 5P_3].$$

Secondly, required the stress (thrust or pull, compression or tension) in each of the pieces A , B , and C cut by the imaginary line DE . The stresses in the pieces are called *internal forces*. These appear in a system of forces acting on a free body only when a portion of the truss or frame is conceived separated from the remainder in such a way as to expose an internal plane of one or more pieces. Consider as a free body the portion on the left of DE (that on the right would serve as well,

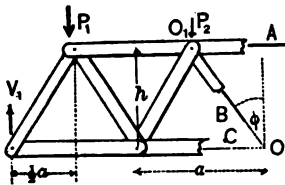

FIG. 39.

but the pulls or thrusts in A , B , and C would be found to act in directions opposite to those they have on the other portion; see § 3). Fig. 39. The arrows (forces) A , B , and C are not pointed yet. They, with V_1 , P_1 , and P_2 , form a system in equilibrium.

$\Sigma(Pa)$ about $O = 0$ gives

$$(Ah) - V_1 2a + P_1 \cdot \frac{1}{2}a + P_2 \cdot \frac{1}{2}a = 0.$$

Therefore the moment $(Ah) = \frac{1}{2}a[4V_1 - 3P_1 - P_2]$, which is positive, since (from above) $4V_1$ is $> 3P_1 + P_2$. Hence A must point to the left, i.e., is a thrust or compression, and is

$$\frac{a}{2h} [4V_1 - 3P_1 - P_2].$$

Similarly, taking moments about O , the intersection of A and B , we have an equation in which the only unknown is C , viz., $(Ch) - V_1 \frac{2}{3}a + P_2 a = 0$. $\therefore (Ch) = \frac{1}{3}a[3V_1 - 2P_1]$,

a positive moment, since $3 V_1$ is $> 2P_1$; $\therefore C$ must point to the right, i.e., is a tension, and $= \frac{a}{2h} [3 V_1 - 2P_1]$.

Finally, to obtain B , put $\Sigma(\text{vert. comps.}) = 0$; i.e. $(B \cos \varphi) + V_1 - P_1 - P_2 = 0$. $\therefore B \cos \varphi = P_1 + P_2 - V_1$; but (see foregoing value of V_1) we may write

$$V_1 = (P_1 + P_2) - (\frac{1}{3}P_1 + \frac{1}{3}P_2) + \frac{1}{3}P_1.$$

$\therefore B \cos \varphi$ will be + (upward) or - (downward), and B will be compression or tension, as $\frac{1}{3}P_1$ is $<$ or $>$ $[\frac{1}{3}P_1 + \frac{1}{3}P_2]$.

$$B = [P_1 + P_2 - V_1] \div \cos \varphi = \frac{\sqrt{h^2 + \frac{1}{4}a^2}}{h} [P_1 + P_2 - V_1].$$

Problem 4.—Given the weight G_1 of rod, the weight G_2 , and all the geometrical elements (the student will assume a

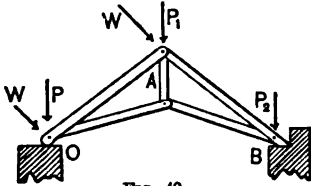

FIG. 40.

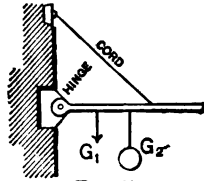

FIG. 41.

convenient notation); required the tension in the cord, and the amount and direction of pressure on hinge-pin.

Problem 5.—Roof-truss; pin-connection; all loads at joints; wind-pressures W and W_1 , normal to OA ; required the three reactions or supporting forces (of the two horizontal surfaces and one vertical surface), and the stress in each piece. All geometrical elements are given; also P , P_1 , P_2 , W (Fig. 40).

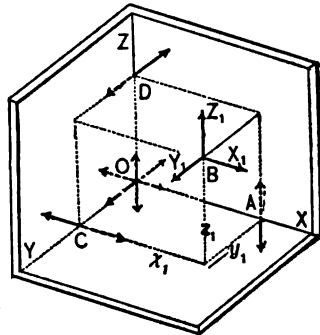

FIG. 42.

38. Composition of Non-concurrent Forces in Space.—Let P_1 , P_2 , etc., be the given forces, and x_1 , y_1 , z_1 , x_2 , y_2 , z_2 , etc., their points of application referred to an arbitrary origin and axes; α_1 , β_1 , γ_1 , etc., the angles made by their lines of application with X , Y , and Z .

Considering the first force P_1 , replace it by its three components parallel to the axes, $X_1 = P_1 \cos \alpha_1$; $Y_1 = P_1 \cos \beta_1$; and $Z_1 = P_1 \cos \gamma_1$ (P_1 itself is not shown in the figure). At O , and also at A , put a pair of equal and opposite forces, each equal and parallel to Z_1 ; Z_1 is now replaced by a single force Z_1 acting upward at the origin, and two couples, one in a plane parallel to YZ and having a moment $= -Z_1 y_1$ (as we see it looking toward O from a remote point on the axis $+X$), the other in a plane parallel to XZ and having a moment $= +Z_1 x_1$ (seen from a remote point on the axis $+Y$). Similarly at O and C put in pairs of forces equal and parallel to X_1 , and we have X_1 , at B , replaced by the single force X_1 at the origin, and the couples, one in a plane parallel to XY , and having a moment $+X_1 y_1$, seen from a remote point on the axis $+Z$, the other in a plane parallel to XZ , and of a moment $= -X_1 z_1$, seen from a remote point on the axis $+Y$; and finally, by a similar device, Y_1 at B is replaced by a force Y_1 at the origin and two couples, parallel to the planes XY and YZ , and having moments $-Y_1 x_1$ and $+Y_1 z_1$, respectively. (In Fig. 42 the single forces at the origin are broken lines, while the two forces constituting any one of the six

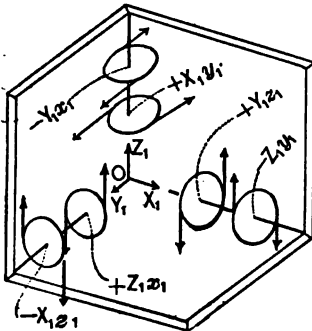

FIG. 43.

couples may be recognized as being equal and parallel, of opposite directions, and both continuous, or both dotted.) We have, therefore, replaced the force P_1 by three forces X_1 , Y_1 , Z_1 , at O , and six couples (shown more clearly in Fig. 43; the couples have been transferred to symmetrical positions). Combining each two couples whose axes are parallel to X , Y , or Z , they can be reduced to three, viz.,

- one with an X axis and a moment $= Y_1 z_1 - Z_1 y_1$;
- one with a Y axis and a moment $= Z_1 x_1 - X_1 z_1$;
- one with a Z axis and a moment $= X_1 y_1 - Y_1 x_1$.

Dealing with each of the other forces P_1, P_2, \dots , in the same manner, the whole system may finally be replaced by three forces $\Sigma X, \Sigma Y$, and ΣZ , at the origin and three couples whose moments are, respectively,

$$\begin{aligned} L &= \Sigma(Yz - Zy) \text{ with its axis parallel to } X; \\ M &= \Sigma(Zx - Xz) \text{ with its axis parallel to } Y; \\ N &= \Sigma(Xy - Yx) \text{ with its axis parallel to } Z. \end{aligned}$$

The "axes" of these couples, being parallel to the respective co-ordinate axes X, Y , and Z , and proportional to the moments L, M , and N , respectively, the axis of their resultant C , whose moment is G , must be the diagonal of a parallelepipedon constructed on the three component axes (proportional to) L, M , and N . Therefore, $G = \sqrt{L^2 + M^2 + N^2}$, while the resultant of $\Sigma X, \Sigma Y$, and ΣZ is

$$R = \sqrt{(\Sigma X)^2 + (\Sigma Y)^2 + (\Sigma Z)^2}$$

acting at the origin. If α, β , and γ are the direction-angles of R , we have $\cos \alpha = \frac{\Sigma X}{R}$, $\cos \beta = \frac{\Sigma Y}{R}$, and $\cos \gamma = \frac{\Sigma Z}{R}$; while if λ, μ , and ν are those of the axis of the couple C , we have $\cos \lambda = \frac{L}{G}$, $\cos \mu = \frac{M}{G}$, and $\cos \nu = \frac{N}{G}$.

For equilibrium we have both $G = 0$ and $R = 0$; i.e., separately, six conditions, viz.,

$$\Sigma X = 0, \Sigma Y = 0, \Sigma Z = 0; \text{ and } L = 0, M = 0, N = 0. \quad (1)$$

Now, noting that $\Sigma X = 0, \Sigma Y = 0$, and $\Sigma(Xy - Yx) = 0$ are the conditions for equilibrium of the system of non-concurrent forces which would be formed by projecting each force of our actual system upon the plane XY , and similar relations for the planes YZ and XZ , we may restate equations (1) in another form, more serviceable in practical problems, viz.:

Note.—If a system of non-concurrent forces in space is in equilibrium, the plane systems formed by projecting the given system upon each of three arbitrary co-ordinate planes will each be in equilibrium. But we can obtain only six independent

equations in any case, available for six unknowns. If R alone $= 0$, we have the system equivalent to a couple C , whose moment $= G$; if G alone $= 0$, the system has a single resultant R applied at the origin. In general, neither R nor G being $= 0$, we cannot further combine R and C (as was done with non-concurrent forces in a plane) to produce a single resultant unless R and C are in the same plane; i.e., when the angle between R and the axis of C is $= 90^\circ$. Call that angle θ . If, then, $\cos \theta = \cos \alpha \cos \lambda + \cos \beta \cos \mu + \cos \gamma \cos \nu$ is $= 0 = \cos 90^\circ$, we may combine R and C to produce a single resultant for the whole system; acting in a plane containing R and parallel to the plane of C in a direction parallel to R , at a perpendicular distance $c = \frac{G}{R}$ from the origin and $= R$ in intensity. The condition that a system of forces in space have a single resultant is, therefore, substituting the previously derived values of the cosines, $(\Sigma X) \cdot L + (\Sigma Y) \cdot M + (\Sigma Z) \cdot N = 0$.

This includes the cases when R is zero and when the system reduces to a couple.

To return to the general case, R and C not being in the same plane, the composition of forces in space cannot be further simplified. Still we can give any value we please to P , one of the forces of the couple C , calculate the corresponding arm $a = \frac{G}{P}$, then transfer C until one of the P 's has the same point of application as R , and combine them by the parallelogram of forces. We thus have the whole system equivalent to two forces, viz., the second P , and the resultant of R and the first P . These two forces are not in the same plane, and therefore cannot be replaced by a single resultant.

39. Problem. (Non-concurrent forces in space.)—Given all geometrical elements (including α, β, γ , angles of P), also the weight of Q , and weight of apparatus G ; A being a hinge whose pin is in the axis Y , O a ball-and-socket joint: required the amount of P (lbs.) to preserve equilibrium, also the pressures

(amount and direction) at A and O ; no friction. Replace P by its X , Y , and Z components. The pressure at A will have

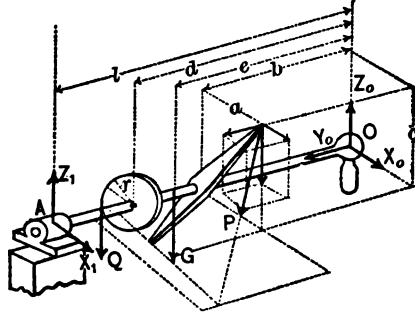

FIG. 44.

Z and X components; that at O , X , Y , and Z components. The body is now free, and there are six unknowns.

ΣX , ΣY , and ΣZ give, respectively,

$$P \cos \alpha + X_1 + X_0 = 0;$$

$$P \cos \beta + Y_0 = 0; \text{ and } Z_1 + Z_0 - Q - G - P \cos \gamma = 0.$$

As for moment-equations (see note in last paragraph), projecting the system upon YZ and putting $\Sigma(Pa)$ about $O = 0$, we have

$$-Z_1 l + Qd + Ge + (P \cos \gamma)b + (P \cos \beta)c = 0;$$

projecting it upon XZ , and putting $\Sigma(Pa)$ about $O = 0$, we have

$$Qr - (P \cos \alpha)c - (P \cos \gamma)a = 0;$$

projecting on XY , moments about O give

$$X_1 l + (P \cos \alpha)b - (P \cos \beta)a = 0.$$

From these six equations we may obtain the six unknowns, P , X_0 , Y_0 , Z_0 , X_1 , and Z_1 . If for any one of these a negative result is obtained, it shows that its direction in Fig. 44 should be reversed.

CHAPTER IV.

STATICS OF FLEXIBLE CORDS.

40. Postulate and Principles.—The cords are perfectly flexible and inextensible. All problems will be restricted to one plane. Solutions of problems are based on three principles, viz.:

PRIN. I.—The strain on a cord at any point can act only along the cord, or along the tangent if it be curved.

PRIN. II.—We may apply to flexible cords in equilibrium all the conditions for the equilibrium of rigid bodies; since, if the system of cords became rigid, it would still, with greater reason, be in equilibrium.

PRIN. III.—The conditions of equilibrium cannot be applied, of course, unless the system can be considered a *free body*, which is allowable only when we conceive to be put in, at the points of support or fastening, the *reactions* (upon the cord) of those points and the supports removed. These reactions having been put in, then consider the case in Fig. 45 in one plane. If we take any point, p , on the cord as a centre of moments, knowing that the resultant R , of the forces P_1 , P_2 , and P_3 , situated on *one side* of p , must act along the cord through p (by Prin. 1), therefore

we have $P_1 a_1 - P_2 a_2 - P_3 a_3 = R \times \text{zero} = 0$, and (equally well) $P_1 a_1 - P_2 a_2 - P_3 a_3 = 0$. That is, *in a system of cords in equilibrium in a plane, if a centre of moments be taken on the cord, the algebraic sum of the mo-*

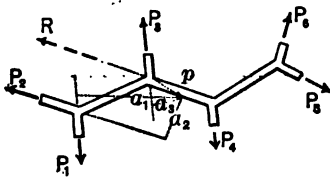

FIG. 45.

ments of those forces situated on one side (either) of this point will equal zero.

41. The Pulley.—A cord in equilibrium over a pulley whose axle is smooth has the same tension on both sides; for, Fig. 46,

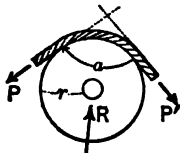

FIG. 46.

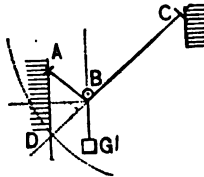

FIG. 47.

considering the pulley and its portion of cord free $\Sigma(Pa) = 0$ about the centre of axle gives $P'r = Pr$, i.e., $P' = P =$ tension in the cord. Hence the pressure R at the axle bisects the angle α , and therefore if a weighted pulley rides upon a cord ABC , Fig. 47, its position of equilibrium, B , may be found by cutting the vertical through A by an arc of radius $CD =$ length of cord, and centre at C , and drawing a horizontal through the middle of AD to cut CD in B . A smooth ring would serve as well as the pulley; this would be a *slip-knot*.

42. If three cords meet at a *fixed knot*, and are in equilibrium, the tension in any one is the equal and opposite of the resultant of those in the other two.

43. Tackle.—If a cord is continuous over a number of sheaves in blocks forming a tackle, neglecting the weight of the cord and blocks and friction of any sort, we may easily find the ratio between the cord-tension P and the weight to be sustained. E.g., Fig. 48, regarding all the straight cords as vertical and considering the block B free, we have, Fig. 49 (from $\Sigma Y = 0$), $4P - G$

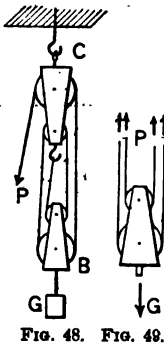

FIG. 48. FIG. 49.

$= 0$, $\therefore P = \frac{G}{4}$. The stress on the support C will $= 5P$.

44. Weights Suspended by Fixed Knots.—Given all the geo-

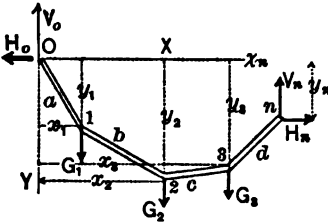

FIG. 50.

metrical elements in Fig. 50, and one weight, G_1 ; required the remaining weights and the forces H_0 , V_0 , H_n and V_n , at the points of support, that equilibrium may obtain. H_0 and V_0 are the horizontal and vertical components of the tension in the cord at O ; similarly H_n and V_n those at n . There are $n + 2$ unknowns. From Prin. II we have $\sum X = 0$, and $\sum Y = 0$; i.e., $H_0 - H_n = 0$, and $[G_1 + G_2 + \dots] - [V_0 + V_n] = 0$. While from Prin. III., taking the successive knots, 1, 2, etc., as centres of moments, we have

$$\begin{aligned} -V_0x_1 + H_0y_1 &= 0, \\ -V_0x_2 + H_0y_2 + G_1(x_2 - x_1) &= 0, \\ -V_0x_3 + H_0y_3 + G_1(x_3 - x_1) + G_2(x_3 - x_2) &= 0, \end{aligned}$$

etc., for n knots.

Thus we have $n + 2$ independent equations, a sufficient number, and they are all of the first degree (with reference to the unknowns), and easily solved. As a special solution, we may, by § 42, resolve G_1 in the directions of the first and second cord-segments, and obtain their tensions by a parallelogram of forces; then at the second knot, knowing the tension in the second segment, we may find that in the third and G_2 in like manner, and so on. Of course H_0 and V_0 are components of the tension in the first segment, H_n and V_n of that in the last.

45. The converse of the problem in § 44, viz., given the weights G_1 , etc., x_n and y_n , the lengths a , b , c , etc.; required H_0 , V_0 , H_n , V_n , and the co-ordinates x_1 , y_1 , x_2 , y_2 , etc., of the fixed knots when equilibrium exists, contains $2n + 2$ unknowns. Statics furnishes $n + 2$ equations (already given in § 44); while geometry gives the other n equations, one for each cord-segment, viz., $x_1^2 + y_1^2 = a^2$; $(x_2 - x_1)^2 + (y_2 - y_1)^2 = b^2$; etc.

However, most of these $2n + 2$ equations are of the second degree; hence in the general case they cannot be solved.

46. Loaded Cord as Parabola.—If the weights are equal and infinitely small, and are intended to be uniformly spaced along the horizontal, when equilibrium obtains, the cord having no weight, it will form a parabola. Let $q =$ weight of loads per horizontal linear unit, O be the vertex of the curve in which the cord hangs, and m any point. We may consider the portion Om as a free body, if

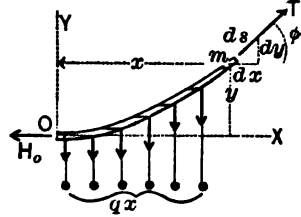

FIG. 51.

the reactions of the contiguous portions of the cord are put in, H_0 and T , and these (from Prin. I.) must act along the tangents to the curve at O and m , respectively; i.e., H_0 is horizontal, and T makes some angle ϕ (whose tangent $= \frac{dy}{dx}$, etc.) with the axis X . Applying Prin. II.,

$$\Sigma X = 0 \text{ gives } T \cos \phi - H_0 = 0; \text{ i.e., } T \frac{dx}{ds} = H_0; \quad \dots (1)$$

$$\Sigma Y = 0 \text{ gives } T \sin \phi - qx = 0; \text{ i.e., } T \frac{dy}{ds} = qx. \quad \dots (2)$$

Dividing (2) by (1), member by member, we have $\frac{dy}{dx} = \frac{qx}{H_0}$;

$\therefore dy = \frac{q}{H_0} x dx$, the differential equation of the curve;

$y = \frac{q}{H_0} \int_0^x x dx = \frac{q}{H_0} \cdot \frac{x^2}{2}$; or $x^2 = \frac{2H_0}{q} y$, the equation of a

parabola whose vertex is at O and axis vertical.

NOTE.—The same result, $\frac{dy}{dx} = \frac{qx}{H_0}$, may be obtained by considering that

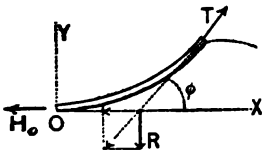

FIG. 52.

we have here (Prin. II.) a free rigid body acted on by three forces, T , H_0 , and $R = qx$, acting vertically through the middle of the abscissa x ; the resultant of H_0 and R must be equal and opposite to T , Fig. 52. $\therefore \tan \phi = \frac{R}{H_0}$, or $\frac{dy}{dx} = \frac{qx}{H_0}$.

Evidently also the tangent-line bisects the abscissa x .

47. Problem under § 46. [Case of a suspension-bridge in which the suspension-rods are vertical, the weight of roadway is uniform per horizontal foot, and large compared with that of the cable and rods. Here the roadway is the only load: it is generally furnished with a stiffening truss to avoid deformation under passing loads.]—Given the span = $2b$, Fig. 53,

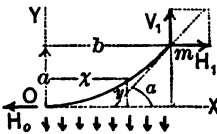

FIG. 53.

the deflection = a , and the rate of loading = q lbs. per horizontal foot; required the tension in the cable at O , also at m ; and the length of cable needed. From the equation of the parabola $qx^2 = 2Hy$, putting $x = b$ and $y = a$, we have $H_0 = qb^2 \div 2a =$ the tension at O . From $\Sigma Y = 0$ we have $V_1 = qb$, while $\Sigma X = 0$ gives

$$H_1 = H_0; \therefore \text{the tension at } m = \sqrt{H_1^2 + V_1^2} = \frac{1}{2a}[qb\sqrt{4a^2 + b^2}].$$

The semi-length, Om , of cable (from p. 88, Todhunter's Integral Calculus) is (letting n denote $H_0 \div 2q, = b^2 \div 4a$)

$$Om = \sqrt{na + a^2} + n \cdot \log. [(\sqrt{a} + \sqrt{n+a}) \div \sqrt{n}].$$

48. The Catenary.*—A flexible, inextensible cord or chain, of uniform weight per unit of length, hung at two points, and supporting *its own weight alone*, forms a curve called the **catenary**. Let the tension H_0 at the lowest point or vertex be represented (for algebraic convenience) by the weight of an imaginary length, c , of similar cord weighing q lbs. per unit of length, i.e., $H_0 = qc$; an actual portion of the cord, of length s , weighs qs lbs. Fig. 54 shows as *free* and in equilibrium a portion of the curve of any length s , reckoning from O the vertex. Required the equation of the curve. The load is uniformly spaced *along the curve*, and not horizontally, as in §§ 46 and 47.

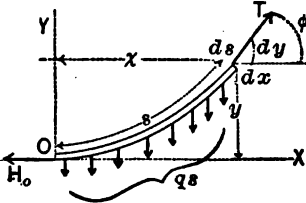

FIG. 54.

$$\Sigma Y = 0 \text{ gives } T \frac{dy}{ds} = qs; \text{ while}$$

$$\Sigma X = 0 \text{ gives } T \frac{dx}{ds} = qc. \text{ Hence, by division, } cdy = sdx, \text{ and squaring, } c^2 dy^2 = s^2 dx^2. \dots \dots \dots (1)$$

* For the "transformed catenary," see p. 395.

Put $dy^2 = ds^2 - dx^2$, and we have, after solving for dx

$$dx = \frac{cds}{\sqrt{s^2 + c^2}} \therefore x = c \int_0^s \frac{ds}{\sqrt{s^2 + c^2}} = c \left[\log_e (s + \sqrt{s^2 + c^2}) \right]$$

and $x = c \cdot \log_e [(s + \sqrt{s^2 + c^2}) \div c]$, . . . (2)

a relation between the horizontal abscissa and length of curve.

Again, in eq. (1) put $dx^2 = ds^2 - dy^2$, and solve for dy .

This gives $dy = \frac{sds}{\sqrt{c^2 + s^2}} = \frac{1}{2} \cdot \frac{d(c^2 + s^2)}{(c^2 + s^2)^{\frac{1}{2}}}$. Therefore

$$y = \frac{1}{2} \int_0^s (c^2 + s^2)^{-\frac{1}{2}} d(c^2 + s^2) = \frac{1}{2} \left[\int_0^s 2(c^2 + s^2)^{\frac{1}{2}} \right], \text{ and finally}$$

$$y = \sqrt{s^2 + c^2} - c. \quad (3)$$

Clearing of radicals and solving for c , we have

$$c = (s^2 - y^2) \div 2y. \quad (4)$$

Example.—A 40-foot chain weighs 240 lbs., and is so hung from two points at the same level that the deflection is 10 feet. Here, for $s = 20$ ft., $y = 10$; hence eq. (4) gives the parameter, $c = (400 - 100) \div 20 = 15$ feet. $q = 240 \div 40 = 6$ lbs. per foot. \therefore the tension at the middle is $H_0 = qc = 6 \times 15 = 90$ lbs.; while the greatest tension is at either support and $= \sqrt{90^2 + 120^2} = 150$ lbs.

Knowing $c = 15$ feet, and putting $s = 20$ feet = half length of chain, we may compute the corresponding value of x from eq. (2); this will be the half-span $[\log_e m = 2.30258 \times (\text{common log } m)]$. To derive s in terms of x , transform eq. (2) in the sense in which $n = \log_e m$ may be transformed into $\epsilon^n = m$, clear of radicals, and solve for s , which gives

$$s = \frac{1}{2} c \left[\epsilon^{\frac{x}{c}} - \epsilon^{-\frac{x}{c}} \right]. \quad (5)$$

Again, eliminate s from (2) by substitution from (3), transform as above, clear of radicals, and solve for $y + c$, whence

$$y + c = \frac{1}{2} c \left[\epsilon^{\frac{x}{c}} + \epsilon^{-\frac{x}{c}} \right], \quad (6)$$

which is the equation of a catenary with axes as in Fig. 54. If the horizontal axis be taken a distance $= c$ below the vertex, the new ordinate $y' = y + c$, while x remains the same; the last equation is simplified.

If the span and length of chain are given, or if the span and deflection are given, c can be determined from (5) or (6) only by successive assumptions and approximations.

48a. Addendum to § 55. Mass.—In PHYSICS, the fundamental units are those of

SPACE, involving a unit of length (and thence of area and volume);

TIME, " a unit of time, usually the second;

MASS, " a unit of mass, which (by Government decree) may be the quantity of matter in a specified piece of platinum, or specified volume of water, etc. (a beam-balance being used to determine equal quantities of mass); while

FORCE involves a derived unit, being measured by its effect in accelerating the velocity of a moving mass, since it is proportional both to the mass and the acceleration. The unit force (called absolute unit) is the force necessary to produce unit acceleration in a unit of mass; so that to produce an acceleration $= p$ in a mass $= m$ requires a force $= F = mp$, and the force thus obtained is in absolute units. This is called the dynamic measure of a force.

Example.—In the C.G.S. system of units, required the constant force necessary to cause a mass of 400 grams to gain 200 velocity units in 2 sec; i.e., $p = 100$ centims. per sec., per sec. From $F = mp$ we have

$$F = 400 \times 100 = 40000 \text{ abs. units of force (or dynes, in C.G.S. system).}$$

In the ft.-lb.-sec. system the absolute unit is called a *poundal*.

In MECHANICS OF ENGINEERING, however, it is more convenient to regard the fundamental units to be those of

SPACE, as ft., metre, etc., area and volume corresponding;

TIME, as seconds, hours, etc.;

FORCE, as lbs., grams, kilograms, tons, etc., indicated by a *spring balance*; while for

MASS we assume a derived unit, a mode of measuring it being developed as follows:

If by experiment (block on smooth table, for instance) we find that a constant force P (lbs., tons, kilos.) will maintain an acceleration $= p$ in the rectilinear motion (in line of force) of a body whose weight (by previous trial with a spring balance) is G (lbs., tons, or other unit); and if in a second experiment, by allowing the force G to act on the same body in vacuo, a free vertical fall with acceleration $= g$ is the result,—we find that the proportion (Newton's 2d Law) $P : G :: p : g$

is verified. This may be written $P = \frac{G}{g} \cdot p$, and may then be read: Force = mass \times acceleration, if we call the quotient G/g the Mass of the body whose weight (by spring balance) is G at a locality where the acceleration of gravity $= g$; for this quotient will be the same at all localities on the earth's surface.

Example (same as above).—If a body whose weight $G = 400$ grams (force) is to have its velocity increased, in 2 sec., from 300 centims. per sec. to 500 centims. per sec., at a uniform rate, we must provide a constant force

$$P = \frac{400}{981} \times 100 = \frac{40000}{981} = 40.77 \text{ grams; or .040 kilos.}$$

This is called the *gravitation measure* of a force. Hence it is evident that to reduce absolute units (called *dynes* and *poundals*) in the C.G.S. and ft.-lb.-sec. systems, respectively) to ordinary practical units of force (lbs., tons, kilos., etc., of a spring balance), we divide by the value of g proper to the system of units employed; and vice versa.

PART II.—DYNAMICS.

CHAPTER I.

RECTILINEAR MOTION OF A MATERIAL POINT.

49. Uniform Motion implies that the moving point passes over equal distances in equal times; **variable motion**, that unequal distances are passed over in equal times. In uniform motion the distance passed over in a unit of time, as one second, is called the **velocity** ($= v$), which may also be obtained by dividing the length of *any portion* ($= s$) of the path by the time ($= t$) taken to describe that portion, however small or great; in variable motion, however, the velocity varies from point to point, its value at any point being expressed as the quotient of ds (an infinitely small distance containing the given point) by dt (the infinitely small portion of time in which ds is described).

49a. By **acceleration** is meant the rate at which the velocity of a variable motion is changing at any point, and may be a *uniform acceleration*, in which case it equals the total change of velocity between any two points, however far apart, divided by the time of passage; or a *variable acceleration*, having a different value at every point, this value then being obtained by dividing the velocity-increment, dv , or gain of velocity in passing from the given point to one infinitely near to it, by dt , the time occupied in acquiring the gain.* (Acceleration must be understood in an algebraic sense, a negative acceleration implying a decreasing velocity, or else that the velocity in a negative direction is increasing.) The foregoing applies to motion in a path or line of any form whatever, the distances mentioned being portions of the path, and therefore measured along the path.

* See addendum on p. 12.

50. Rectilinear Motion, or motion in a straight line.—The general relations of the quantities involved may be thus stated (see Fig. 55): Let v = velocity of the body at any instant; then dv = gain of velocity in an instant of time dt . Let t = time elapsed since the body left a given fixed point,

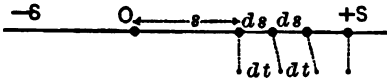

FIG. 55.

which will be taken as an origin, O . Let s = distance (+ or -) of the body, at any instant, from the origin O ; then ds = distance traversed in a time dt . Let p = acceleration = rate at which v is increasing at any instant. All these may be variable; and t is taken as the **independent variable**, i.e., time is conceived to elapse by *equal* small increments, each = dt ; hence two consecutive ds 's will not in general be equal, their difference being called d^2s . Evidently d^2t is = zero, i.e., dt is constant.

Since $\frac{1}{dt}$ = number of instants in one second, the velocity at any instant (i.e., the distance which *would* be described at that rate in one second) is $v = ds \cdot \frac{1}{dt}$; $\therefore v = \frac{ds}{dt}$ (I.)

Similarly, $p = dv \cdot \frac{1}{dt}$, and $\left(\text{since } dv = d\left(\frac{ds}{dt}\right) = \frac{d^2s}{dt^2} \right)$,

$$\therefore p = \frac{dv}{dt} = \frac{d^2s}{dt^2} \quad \dots \dots \dots \text{(II.)}$$

Eliminating dt , we have also $v dv = p ds$ (III.)

These are the fundamental differential formulæ of rectilinear motion (for curvilinear motion we have these and some in addition) as far as kinematics, i.e., as far as space and time, is concerned. The consideration of the mass of the material point and the forces acting upon it will give still another relation (see § 55).

51. Rectilinear Motion due to Gravity.—If a material point fall freely in vacuo, no initial direction other than vertical having been given to its motion, many experiments have

shown that this is a uniformly accelerated rectilinear motion in a vertical line having an acceleration (called the *acceleration of gravity*) equal to 32.2 feet per square second, or 9.81 metres per square second; i.e., the velocity increases at this constant rate in a downward direction, or decreases in an upward direction.

[NOTE.—By “square second” it is meant to lay stress on the fact that an acceleration (being = $d^2s + dt^2$) is in quality equal to one dimension of length divided by two dimensions of time. E.g., if instead of using the foot and second as units of space and time we use the foot and the minute, g will = 32.2×3600 ; whereas a velocity of say six feet per second would = 6×60 feet per minute. The value of $g = 32.2$ implies the units foot and second, and is sufficiently exact for practical purposes.]

52. Free Fall in Vacuo.—Fig. 56. Let the body start at O with an initial downward velocity = c . The acceleration is constant and = $+g$. Reckoning both time and distance (+ downwards) from O , required the values of the variables s and v after any time t . From eq. (II.), § 50, we have $+g = dv \div dt$; $\therefore dv = gdt$, in which the two variables are separated.

Hence $\int_c^v dv = g \int_0^t dt$; i.e., $\left[v = g \left[\begin{matrix} t \\ 0 \end{matrix} \right] \right]$; or $v - c =$



$gt - 0$; and finally, $v = c + gt$ (1) FIG. 56.

(Notice the correspondence of the limits in the foregoing operation; when $t = 0$, $v = +c$.)
From eq. (I.), § 50, $v = ds \div dt$; \therefore substituting from (1), $ds = (c + gt)dt$, in which the two variables s and t are separated.

$\therefore \int_0^s ds = c \int_0^t dt + g \int_0^t t dt$; i.e., $\left[s = c \left[\begin{matrix} t \\ 0 \end{matrix} \right] + g \left[\begin{matrix} t^2 \\ 0 \end{matrix} \right] \frac{1}{2} \right]$,
or $s = ct + \frac{1}{2}gt^2$ (2)

Again, eq. (III.), § 50, $v dv = g ds$, in which the variables v and s are already separated.

$\therefore \int_c^v v dv = g \int_0^s ds$; or $\left[\frac{1}{2}v^2 = g \left[\begin{matrix} s \\ 0 \end{matrix} \right] \right]$; i.e., $\frac{1}{2}(v^2 - c^2) = gs$,
or $s = \frac{v^2 - c^2}{2g}$ (3)

If the initial velocity = zero, i.e., if the body falls from rest, eq. (3) gives $s = \frac{v^2}{2g}$ and $v = \sqrt{2gh}$.* [From the frequent recurrence of these forms, especially in hydraulics, $\frac{v^2}{2g}$ is called the "height due to the velocity v ," i.e., the vertical height through which the body must fall from rest to acquire the velocity v ; while, conversely, $\sqrt{2gh}$ is called the velocity due to the height or head h .]

By eliminating g between (1) and (3), we may derive another formula between three variables, s , v , and t , viz.,

$$s = \frac{1}{2}(c + v)t. \quad \dots \dots \dots (4)$$

53. Upward Throw.—If the initial velocity were in an upward direction in Fig. 56 we might call it $-c$, and introduce it with a negative sign in equations (1) to (4), just derived; but for variety let us call the upward direction $+$, in which case an upward initial velocity would = $+c$, while the acceleration = $-g$, constant, as before. (The motion is supposed confined within such a small range that g does not sensibly vary.) Fig.

57. From $p = dv \div dt$ we have $dv = -gdt$ and

$$\int_0^v dv = -g \int_0^t dt; \therefore v - c = -gt; \text{ or } v = c - gt. \quad (1)a$$

From $v = ds \div dt$, $ds = cdt - gtdt$,

$$\text{i.e., } \int_0^s ds = c \int_0^t dt - g \int_0^t tdt; \text{ or } s = ct - \frac{1}{2}gt^2. \quad (2)a$$

$v dv = pds$ gives $\int_0^v v dv = -g \int_0^s ds$, whence

$$\frac{1}{2}(v^2 - c^2) = -gs, \text{ or finally, } s = \frac{c^2 - v^2}{2g}. \quad \dots \dots \dots (3)a$$

And by eliminating g from (1)a and (3)a,

$$s = \frac{1}{2}(c + v)t. \quad \dots \dots \dots (4)a$$

The following is now easily verified from these equations: the body passes the origin again ($s = 0$) with a velocity = $-c$, after a lapse of time = $2c \div g$. The body comes to rest (for

* In Hydraulics h is used instead of s .

an instant) (put $v = 0$) after a time $= c \div g$, and at a distance $s = c^2 \div 2g$ ("height due to velocity c ") from O . For $t > c \div g$, v is negative, showing a downward motion; for $t > 2c \div g$, s is negative, i.e., the body is below the starting-point while the rate of change of v is constant and $= -g$ at all points.

54. Newton's Laws.—As showing the relations existing in general between the motion of a material point and the actions (forces) of other bodies upon it, experience furnishes the following three laws or statements as a basis for dynamics:

(1) A material point under no forces, or under balanced forces, remains in a state of rest or of uniform motion in a right line. (This property is often called *Inertia*.)

(2) If the forces acting on a material point are unbalanced, an acceleration of motion is produced, proportional to the resultant force and in its direction.

(3) Every action (force) of one body on another is always accompanied by an equal, opposite, and simultaneous reaction. (This was interpreted in § 3.)

As all bodies are made up of material points, the results obtained in Dynamics of a Material Point serve as a basis for the Dynamics of a Rigid Body, of Liquids, and of Gases.

55. Mass.*—If a body is to continue moving in a right line, the resultant force P at all instants must be directed along that line (otherwise it would have a component deflecting the body from its straight course).

In accordance with Newton's second law, denoting by p the acceleration produced by the resultant force (G being the body's weight), we must have the proportion $P : G :: p : g$; i.e.,

$$P = \frac{G}{g} \cdot p \dots \dots \dots, \text{ or } P = Mp. \dots \dots \text{ (IV.)}$$

Eq. IV. and (I.), (II.), (III.) of § 50 are the fundamental equations of Dynamics. Since the quotient $G \div g$ is invaria-

* See Addendum on p. 48.

ble, wherever the body be moved on the earth's surface (G and g changing in the same ratio), it will be used as the measure of the mass M or quantity of matter in the body. In this way it will frequently happen that the quantities G and g will appear in problems where the weight of the body, i.e., the force of the earth's attraction upon it, and the acceleration of gravity have no direct connection with the circumstances. No name will be given to the unit of mass, it being always understood that the fraction $G \div g$ will be put for M before any numerical substitution is made. From (IV.) we have, in words,

$$\left\{ \begin{array}{l} \text{accelerating force} = \text{mass} \times \text{acceleration}; \\ \text{also, } \text{acceleration} = \text{accelerating force} \div \text{mass}. \end{array} \right.$$

56. Uniformly Accelerated Motion.—If the resultant force is constant as time elapses, the acceleration must be constant (from eq. (IV.), since of course M is constant) and $= P \div M$. The motion therefore will be uniformly accelerated, and we have only to substitute $+p$ (constant) for g in eqs. (1) to (4) of § 52 for the equations of this motion, the initial velocity being $= c$ (in the line of the force).

$$v = c + pt \quad . . . (1); \quad s = ct + \frac{1}{2}pt^2; \quad . . . (2)$$

$$s = \frac{(v^2 - c^2)}{2p}; \quad . . . (3), \quad \text{and } s = \frac{1}{2}(c + v)t \quad . . . (4)$$

If the force is in a negative direction, the acceleration will be negative, and may be called a *retardation*; the initial velocity should be made negative if its direction requires it.

57. Examples of Unif. Acc. Motion.—*Example 1.* Fig. 58. A small block whose weight is $\frac{1}{2}$ lb. has already described a

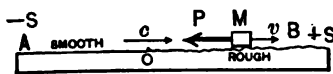

FIG. 58.

distance $Ao = 48$ inches over a smooth portion of a horizontal table in two seconds; at O it en-

counters a rough portion, and a consequent constant friction of 2 oz. Required the distance described beyond O , and the time occupied in coming to rest. Since we shall use 32.2 for g , times must be in seconds, and distances in feet; as to the unit

of force, as that is still arbitrary, say ounces. Since AO was smooth, it must have been described with a uniform motion (the resistance of the air being neglected); hence with a velocity $= 4 \text{ ft.} \div 2 \text{ sec.} = 2 \text{ ft. per sec.}$ The initial velocity for the retarded motion, then, is $c = + 2$ at O . At any point beyond O the acceleration $= \text{force} \div \text{mass} = (- 2 \text{ oz.}) \div (8 \text{ oz.} \div 32.2) = - 8.05 \text{ ft. per square second, i.e., } p = - 8.05 = \text{constant}$; hence the motion is uniformly accelerated (retarded here), and we may use the formulæ of § 56 with $c = + 2, p = - 8.05$. At the end of the motion v must be zero, and the corresponding values of s and t may be found by putting $v = 0$ in equations (3) and (1), and solving for s and t respectively: thus from (3), $s = \frac{1}{2}(-4) \div (-8.05)$, i.e., $s = 0.248 +$, which must be feet; while from (1), $t = (-2) \div (-8.05) = 0.248 +$, which must be seconds.

Example 2. (Algebraic.)—Fig. 59. The two masses $M_1 = G_1 \div g$ and $M = G \div g$ are connected by a flexible, inextensible cord. Table smooth. Required the acceleration common to the two rectilinear motions, and the tension in the string S ,

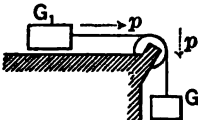

FIG. 59.

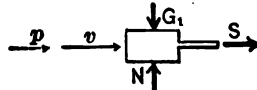

FIG. 60.

there being no friction under G_1 , none at the pulley, and *no mass* in the latter or in the cord. At any instant of the motion consider G_1 free (Fig. 60), N being the pressure of the table against G_1 . Since the motion is in a horizontal right line $\Sigma(\text{vert. comps.}) = 0$, i.e., $N - G_1 = 0$, which determines N . S , the only horizontal force (and resultant of all the forces) $= M_1 p$, i.e.,

$$S = G_1 p \div g. \dots \dots \dots (1)$$

At the same instant of the motion consider G free (Fig. 61); the tension in the cord is the same value as above $= S$. The accelerating force is $G - S$, and

$$\therefore = \text{mass} \times \text{acc., or } G - S = (G \div g)p. \dots (2)$$

From equations (1) and (2) we obtain $p = (Gg) \div (G + G_1) = \text{a constant}$; hence each motion is *uniformly accelerated*, and we may employ equations (1) to (4) of § 56 to find the velocity and distance from the starting-points, at the end of any assigned time t , or *vice versa*.

FIG. 61. The initial velocity must be known, and may be zero. Also, from (1) and (2) of this article,

$$S = (GG_1) \div (G + G_1) = \text{constant.}$$

Example 3.—A body of $2\frac{1}{2}$ (short) tons weight is acted on during $\frac{1}{4}$ minute by a constant force P . It had previously described $316\frac{3}{4}$ yards in 180 seconds under no force; and subsequently, under no force, describes 9900 inches in $\frac{1}{10}$ of an hour. Required the value of P . Ans. $P = 22.1$ lbs.

Example 4.—A mass of 1 ton weight, having an initial velocity of 48 inches per second, is acted on for $\frac{1}{2}$ minute by a force of 400 avoirdupois ounces. Required the final velocity. Ans. 10.037 ft. per sec.

Example 5.—Initial velocity, 60 feet per second; mass weighs 0.30 of a ton. A resistance of $112\frac{1}{2}$ lbs. retards it for $\frac{1}{10}$ of a minute. Required the distance passed over during this time. Ans. 286.8 feet.

Example 6.—Required the time in which a force of 600 avoirdupois ounces will increase the velocity of a mass weighing $1\frac{1}{4}$ tons from 480 feet per minute to 240 inches per second. Ans. 30 seconds.

Example 7.—What distance is passed over by a mass of (0.6) tons weight during the overcoming of a constant resistance (friction), if its velocity, initially 144 inches per sec., is reduced to zero in 8 seconds. Required, also, the friction. Ans. 48 ft. and 55 lbs.

Example 8.—Before the action of a force (value required) a body of 11 tons had described uniformly 950 ft. in 12 minutes. Afterwards it describes 1650 feet uniformly in 180 seconds. The force acts 30 seconds. $P = ?$ Ans. $P = 178$ lbs.

58. Graphic Representations. Unif. Acc. Motion.—With the initial velocity = 0, the equations of § 56 become

$$v = pt, \dots (1) \quad s = \frac{1}{2}pt^2, \dots (2)$$

$$s = v^2 \div 2p, \dots (3) \quad \text{and} \quad s = \frac{1}{2}vt. \dots (4)$$

Eqs. (1), (2), and (3) contain each two variables, which may graphically be laid off to scale as co-ordinates and thus give a curve corresponding to the equation. Thus, Fig. 62, in (I.), we

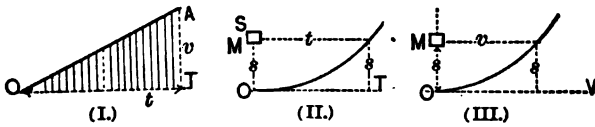

FIG. 62.

have a right line representing eq. (I.); in (II.), a parabola with axis parallel to s , and vertex at the origin for eq. (2); also a parabola similarly situated for eq. (3). Eq. (4) contains three variables, s , v , and t . This relation can be shown in (I.), s being represented by the *area* of the shaded triangle = $\frac{1}{2}vt$. (II.) and (III.) have this advantage, that the axis OS may be made the actual path of the body. [Let the student determine how the origin shall be moved in each case to meet the supposition of an initial velocity = $+c$ or $-c$.]

59. Variably Accelerated Motions.—We here restate the equations

$$v = \frac{ds}{dt} \dots (I.); \quad p = \frac{dv}{dt} = \frac{d^2s}{dt^2} \dots (II.); \quad vdv = pds \dots (III.);$$

and resultant force

$$= P = Mp, \dots (IV.);$$

which are the only ones for *general use* in rectilinear motion.

PROBLEM 1.—In pulling a mass M along a smooth, horizontal table, by a horizontal cord, the tension is so varied that $s = 4t^2$ (*not a homogeneous equation*; the units are, say, the foot and second). Required by what law the tension varies.

From (I.) $v = \frac{ds}{dt} = \frac{d(4t^2)}{dt} = 12t$; from (II.), $p = \frac{d(12t^2)}{dt} = 24t$; and (IV.) the tension = $P = Mp = 24Mt$, i.e., varies directly as the time.

PROBLEM 2. "Harmonic Motion," Fig. 63.—A small block

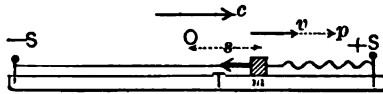

FIG. 63

on a smooth horizontal table is attached to two horizontal elastic cords (and they to pegs) in such a way that when the block is at O , each cord is straight but not tense; in any other position, as m , one cord is tense, the other slack. The cords are alike in every respect, and, as with springs, the tension varies directly with the elongation ($= s$ in figure). If for an elongation s_1 the tension is T_1 , then for any elongation s it is $T = T_1 s \div s_1$. The acceleration at any point m , then, is $p = -(T \div M) = -(T_1 s \div Ms_1)$, which for brevity put $p = -as$, a being a constant. Required the equations of motion, the initial velocity being $= +c$, at O . From eq. (III.)

$$v dv = -as ds; \therefore \int_c^v v dv = -a \int_0^s s ds,$$

$$\text{i.e., } \frac{1}{2}(v^2 - c^2) = -\frac{1}{2}as^2; \text{ or, } v^2 = c^2 - as^2. \quad (1)$$

From (I.), $dt = ds \div v$; hence from (1),

$$\int_0^t dt = \int_0^s [ds \div \sqrt{c^2 - as^2}],$$

or

$$\begin{aligned} t &= \frac{1}{\sqrt{a}} \int_0^s \frac{d[s\sqrt{a} \div c]}{\sqrt{1 - (s\sqrt{a} \div c)^2}} = \frac{1}{\sqrt{a}} \left[\sin^{-1} \left(\frac{s\sqrt{a}}{c} \right) \right] \\ &= \frac{1}{\sqrt{a}} \sin^{-1} \left(\frac{s\sqrt{a}}{c} \right). \quad \dots \dots \dots (2) \end{aligned}$$

Inverting (2), we have $s = (c \div \sqrt{a}) \sin (t \sqrt{a})$, . . . (3)

Again, by differentiating (3), see (I.), $v = c \cos (t \sqrt{a})$ (4)

Differentiating (4), see (II.), $p = -c \sqrt{a} \sin (t \sqrt{a})$. . . (5)

These are the relations required, but the peculiar property of the motion is made apparent by inquiring the time of passing from O to a state of rest; i.e., put $v = 0$ in equation (4), we obtain $t = \frac{1}{2}\pi \div \sqrt{a}$, or $\frac{3}{2}\pi \div \sqrt{a}$, or $\frac{5}{2}\pi \div \sqrt{a}$, and so on, while the corresponding values of s (from equation (3)), are $+(c \div \sqrt{a})$, $-(c \div \sqrt{a})$, $+(c \div \sqrt{a})$, and so on. This shows that the body vibrates equally on both sides of O in a cycle or period whose duration = $2\pi \div \sqrt{a}$, and is *independent of the initial velocity given it at O* . Each time it passes O the velocity is either $+c$, or $-c$, the acceleration = 0, and the time since the start is = $n\pi \div \sqrt{a}$, in which n is any whole number. At the extreme point $p = \mp c \sqrt{a}$, from eq. (5). If then a different amplitude be given to the oscillation by changing c , the duration of the period is still the same, i.e., the vibration is *isochronal*. The motion of an ordinary pendulum is nearly, that of a cycloidal pendulum exactly, harmonic.

If the crank-pin of a reciprocating engine moved uniformly in its circular path, the piston would have a harmonic motion if the connecting-rod were infinitely long, or if the design in

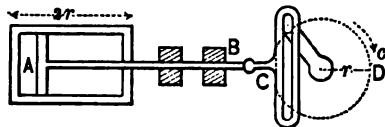

FIG. 64.

Fig. 64 were used. (Let the student prove this from eq. (3).) Let $2r =$ length of stroke, and $c =$ the uniform velocity of the crank-pin, and $M =$ mass of the piston and rod AB . Then the velocity of M at mid-stroke must = c , at the dead-points, zero; its acceleration at mid-stroke zero; at the dead-points the acc. = $c \sqrt{a}$, and $s = r = c \div \sqrt{a}$ (from eq. (3)); $\therefore \sqrt{a} = c \div r$, and the acc. at a dead point (the maximum acc.)

$= c^2 \div r$. Hence on account of the acceleration (or retardation) of M in the neighborhood of a dead-point a pressure will be exerted on the crank-pin, equal to mass \times acc. $= Mc^2 \div r$ at those points, independently of the force transmitted due to steam-pressure on the piston-head, and makes the resultant pressure on the pin at C smaller, and at D larger than it would be if the "inertia" of the piston and rod were not thus taken into account. We may prove this also by the free-body method, considering AB free immediately after passing the dead-point

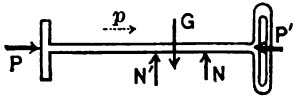

FIG. 65.

C , neglecting all friction. See Fig. 65. The forces acting are: G , the weight; N , the pressures of the guides; P , the known effective steam-pressure on piston-head; and P' , the unknown pressure of crank-pin on side of slot. There is no change of motion vertically; $\therefore N' + N - G = 0$, and the resultant force is $P - P' = \text{mass} \times \text{accel.} = Mc^2 \div r$, hence $P' = P - Mc^2 \div r$. Similarly at the other dead-point we would obtain $P' = P + Mc^2 \div r$. In high-speed engines with heavy pistons, etc., $Mc^2 \div r$ is no small item. [The upper half-revol., alone, is here considered.]

PROBLEM 3.—Supposing the earth at rest and the resistance of the air to be null, a body is given an initial upward vertical velocity $= c$. Required the velocity at any distance s from the centre of the earth, whose attraction varies inversely as the square of the distance s .

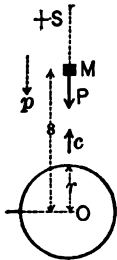

FIG. 66.

See Fig. 66.—The attraction on the body at the surface of the earth where $s = r$, the radius, is its weight G ; at any point m it will be $P = G(r^2 \div s^2)$, while its mass $= G \div g$.

Hence the acceleration at $m = p = (-P) \div M = -g(r^2 \div s^2)$. Take equation III., $v dv = p ds$, and we have

$$v dv = -gr^2 s^{-2} ds; \therefore \int_c^v v dv = -gr^2 \int_r^s s^{-2} ds; \text{ or, } \left[\frac{1}{2} v^2 \right]_c^v = -gr^2 \left[-\frac{1}{s} \right]_r^s, \\ \text{i.e., } \frac{1}{2}(v^2 - c^2) = -gr^2 \left(\frac{1}{r} - \frac{1}{s} \right). \dots (1)$$

Evidently v decreases, as it should. Now inquire how small a value c may have that the body shall *never return*; i.e., that v shall not = 0 until $s = \infty$. Put $v = 0$ and $s = \infty$ in (1) and solve for c ; and we have

$$c = \sqrt{2gr} = \sqrt{2 \times 32.2 \times 21000000},$$

= about 36800 ft. per sec. or nearly 7 miles per sec. Conversely, if a body be allowed to fall, from rest, toward the earth, the velocity with which it would strike the surface would be less than seven miles per second through whatever distance it may have fallen.

If a body were allowed to fall through a straight opening in the earth passing through the centre, the motion would be harmonic, since the attraction and consequent acceleration now vary directly with the distance from the centre. See Prob. 2. This supposes the earth homogeneous.

PROBLEM 4.—Steam working expansively and raising a weight.

Fig. 67.—A piston works without friction in a vertical cylinder. Let S = total steam-pressure on the underside of the piston; the weight G , of the mass $G \div g$ (which includes the piston itself) and an atmospheric pressure = A , constitute a constant back-pressure.

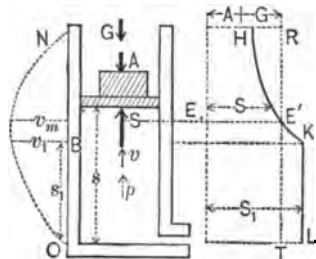

FIG. 67.

Through the portion $OB = s_1$, of the stroke, S is constant = S_1 , while beyond B , boiler communication being "cut off," S diminishes with Boyle's law, i.e., in this case, for any point above B , we have, neglecting the "clearance", F being the cross-section of the cylinder,

$$S : S_1 :: F s_1 : F s; \text{ or } S = S_1 s_1 \div s.$$

Full length of stroke = $ON = s_n$. Given, then, the forces S_1 and A , the distances s_1 and s_n , and the velocities at O and at N both = 0 (i.e., the mass $M = G \div g$ is to start from rest at O , and to come to rest at N), required the proper weight G to

fulfil these conditions, S varying as already stated. The acceleration at any point will be

$$p = [S - A - G] \div M. \quad . \quad . \quad . \quad (1)$$

Hence (eq. III.) $Mvdv = [S - A - G]ds$, and \therefore for the whole stroke

$$M \int_0^N vdv = \int_0^N [S - A - G]ds; \text{ i.e.,}$$

$$0 = S_1 \int_0^{s_1} ds + S_1 s_1 \int_{s_1}^{s_n} \frac{ds}{s} - A \int_0^{s_n} ds - G \int_0^{s_n} ds,$$

$$\text{or} \quad S_1 s_1 \left[1 + \log_e \frac{s_n}{s_1} \right] = A s_n + G s_n. \quad . \quad . \quad (2)$$

Since $S = S_1 = \text{constant}$, from O to B , and variable, $= S_1 s_1 \div s$, from B to N , we have had to write the summation $\int_0^N S ds$ in two parts.

From (2), G becomes known, and $\therefore M$ also ($= G \div g$).

Required, further, the time occupied in this upward stroke. From O to B (the point of cut-off) the motion is uniformly accelerated, since p is constant (S being $= S_1$ in eq. (1)), with the initial velocity zero; hence, from eq. (3), § 56, the velocity at $B = v_1 = \sqrt{2 [S_1 - A - G] s_1} \div M$ is known; \therefore the time $t_1 = 2s_1 \div v_1$ becomes known (eq. (4), § 56) of describing OB . At any point beyond B the velocity v may be obtained thus: From (III.) $v dv = p ds$, and eq. (1) we have, summing between B and any point above,

$$M \int_{v_1}^v v dv = S_1 s_1 \int_{s_1}^s \frac{ds}{s} - (A + G) \int_{s_1}^s ds; \text{ i.e.,}$$

$$\frac{G (v^2 - v_1^2)}{g} = S_1 s_1 \log_e \frac{s}{s_1} - (A + G) (s - s_1).$$

This gives the relation between the two variables v and s anywhere between B and N ; if we solve for v and insert its value in $dt = ds \div v$, we shall have $dt = \text{a function of } s \text{ and } ds$, which is not integrable. Hence we may resort to approxi-

mate methods for the time from B to N . Divide the space BN into an uneven number of equal parts, say five; the distances of the points of division from O will be s_1, s_2, s_3, s_4, s_5 , and s_n . For these values of s compute (from above equation) v_1 (already known), v_2, v_3, v_4, v_5 , and v_n (known to be zero). To the first four spaces apply Simpson's Rule, and we have the time from B to the end of s_4 ,

$$\left[\int_1^4 t = \int_1^4 \frac{ds}{v}; \text{ approx.} = \frac{s_4 - s_1}{12} \left[\frac{1}{v_1} + \frac{4}{v_2} + \frac{2}{v_3} + \frac{4}{v_4} + \frac{1}{v_5} \right]; \right.$$

while regarding the motion from 5 to N as uniformly retarded (approximately) with initial velocity = v_5 and the final = zero, we have (eq. (4), § 56),

$$\left[\int_4^N t = 2(s_n - s_4) \div v_5. \right.$$

By adding the three times now found we have the whole time of ascent. In Fig. 67 the dotted curve on the left shows by horizontal ordinates the variation in the velocity as the distance s increases; similarly on the right are ordinates showing the variation of S . The point E , where the velocity is a maximum = v_m , may be found by putting $p = 0$, i.e., for $S = A + G$, the accelerating force being = 0, see eq. (1). Below E the accelerating force, and consequently the acceleration, is positive; above, negative (i.e., the back-pressure exceeds the steam-pressure). The horizontal ordinates between the line $HEKL$ and the right line RT are proportional to the accelerating force. If by condensation of the steam a vacuum is produced below the piston on its arrival at N , the accelerating force is downward and = $A + G$. [Let the student determine how the detail of this problem would be changed, if the cylinder were horizontal instead of vertical.]

60. Direct Central Impact.—Suppose two masses M_1 and M_2 to be moving in the same right line so that their distance apart continually diminishes, and that when the collision or impact takes place the line of action of the mutual pressure coincides with the line joining their centres of gravity, or centres of

mass, as they may be called in this connection. This is called a direct central impact, and the motion of each mass is variably accelerated and rectilinear during their contact, the only force being the pressure of the other body. The whole mass of each body will be considered concentrated in the centre of mass, on the supposition that all its particles undergo simultaneously the same change of motion in parallel directions. (This is not strictly true; the effect of the pressure being gradually felt, and transmitted in vibrations. These vibrations endure to some extent after the impact.) When the centres of mass cease to approach each other the pressure between the bodies is a maximum and the bodies have a common velocity; after this, if any capacity for restitution of form (elasticity) exists in either body, the pressure still continues, but diminishes in value gradually to zero, when contact ceases and the bodies separate with different velocities. Reckoning the time from the first instant of contact, let t' = duration of the first period, just mentioned; t'' that of the first + the second (restitution). Fig. 68. Let M_1 and M_2 be the masses, and at any

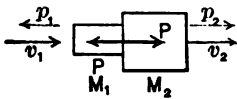

FIG. 68.

instant during the contact let v_1 and v_2 be simultaneous values of the velocities of the mass-centres respectively (reckoning velocities positive toward the right), and P the pressure (variable). At any instant the acceleration of M_1 is $p_1 = -(P \div M_1)$, while at the same instant that of M_2 is $p_2 = +(P \div M_2)$; M_1 being retarded, M_2 accelerated, in velocity. Hence (eq. II., $p = dv \div dt$) we have

$$M_1 dv_1 = -P dt; \quad \text{and} \quad M_2 dv_2 = +P dt. \quad \dots (1)$$

Summing all similar terms for the first period of the impact, we have (calling the velocities before impact c_1 and c_2 , and the common velocity at instant of maximum pressure C)

$$M_1 \int_{c_1}^C dv_1 = - \int_0^{t'} P dt, \quad \text{i.e.,} \quad M_1(C - c_1) = - \int_0^{t'} P dt; \quad (2)$$

$$M_2 \int_{c_2}^C dv_2 = + \int_0^{t'} P dt, \quad \text{i.e.,} \quad M_2(C - c_2) = + \int_0^{t'} P dt. \quad (3)$$

The two integrals are identical, numerically, term by term, since the pressure which at any instant accelerates M_1 is numerically equal to that which retards M_2 ; hence, though we do not know how P varies with the time, we can eliminate the definite integral between (2) and (3) and solve for C . If the impact is *inelastic* (i.e., no power of restitution in either body, either on account of their total inelasticity or damaging effect of the pressure at the surfaces of contact), they continue to move with this common velocity, which is therefore their final velocity. Solving, we have

$$C = \frac{M_1 c_1 + M_2 c_2}{M_1 + M_2} \dots \dots \dots (4)$$

Next, supposing that the impact is *partially elastic*, that the bodies are of the same material, and that the summation

$\int_{t'}^{t''} P dt$ for the second period of the impact bears a ratio, e , to that $\int_0^{t''} P dt$, already used, a ratio peculiar to the material,

if the impact is not too severe, we have, summing equations (1) for the second period (letting V_1 and V_2 = the velocities after impact),

$$M_1 \int_C^{V_1} dv_1 = - \int_{t'}^{t''} P dt, \text{ i.e., } M_1 (V_1 - C) = - e \int_0^{t''} P dt; (5)$$

$$M_2 \int_C^{V_2} dv_2 = + \int_{t'}^{t''} P dt, \text{ i.e., } M_2 (V_2 - C) = + e \int_0^{t''} P dt. (6)$$

e is called the coefficient of restitution.

Having determined the value of $\int_0^{t''} P dt$ from (2) and (3) in terms of the masses and initial velocities, substitute it and that of C , from (4), in (5), and we have (for the final velocities)

$$V_1 = [M_1 c_1 + M_2 c_2 - e M_2 (c_1 - c_2)] \div [M_1 + M_2]; \dots (7)$$

and similarly

$$V_2 = [M_1 c_1 + M_2 c_2 + e M_1 (c_1 - c_2)] \div [M_1 + M_2]. \dots (8)$$

For $e = 0$, i.e., for *inelastic impact*, $V_1 = V_2 = C$ in eq. (4); for

$e = 1$, or *elastic impact*, (7) and (8) become somewhat simplified.

To determine e experimentally, let a ball (M_1) of the substance fall upon a very large slab (M_2) of the same substance, noting both the height of fall h_1 , and the height of rebound H_1 . Considering M_2 as $= \infty$, with

$$c_1 = \sqrt{2gh_1}, \quad V_1 = -\sqrt{2gH_1}, \quad \text{and } c_2 = 0,$$

eq. (7) gives

$$-\sqrt{2gH_1} = -e\sqrt{2gh_1}; \quad \therefore e = \sqrt{H_1 \div h_1}.$$

Let the student prove the following from equations (2), (3), (5), and (6):

(a) For any direct central impact whatever,

$$M_1c_1 + M_2c_2 = M_1V_1 + M_2V_2.$$

[The product of a mass by its velocity being sometimes called its *momentum*, this result may be stated thus:

In any direct central impact the sum of the momenta before impact is equal to that after impact (or at any instant during impact). This principle is called the *Conservation of Momentum*. The present is only a particular case of a more general proposition.

It may be proved C , eq. (4), is the velocity of the centre of gravity of the two masses before impact; the conservation of momentum, then, asserts that this velocity is unchanged by the impact, i.e., by the mutual actions of the two bodies.]

(b) The loss of velocity of M_1 , and the gain of velocity of M_2 , are twice as great when the impact is elastic as when inelastic.

(c) If $e = 1$, and $M_1 = M_2$, then $V_1 = +c_2$, and $V_2 = c_1$.

Example.—Let M_1 and M_2 be perfectly elastic, having weights = 4 and 5 lbs. respectively, and let $c_1 = 10$ ft. per sec. and $c_2 = -6$ ft. per sec. (i. e., before impact M_2 is moving in a direction contrary to that of M_1). By substituting in eqs. (7) and (8), with $e = 1$, $M_1 = 4 + g$, and $M_2 = 5 + g$, we have

$$V_1 = \frac{1}{9} [4 \times 10 + 5 \times (-6) - 5 (10 - (-6))] = -7.7 \text{ ft. per sec.}$$

$$V_2 = \frac{1}{9} [4 \times 10 + 5 \times (-6) + 4 (10 - (-6))] = +8.2 \text{ ft. per sec.}$$

as the velocities after impact. Notice their directions, as indicated by their signs

CHAPTER II.

“VIRTUAL VELOCITIES.”

61. Definitions.—If a material point is moving in a direction not coincident with that of the resultant force acting (as in curvilinear motion in the next chapter), and any element of its path, ds , projected upon this force;* the length of this projection, du , Fig. 69, is called the “VIRTUAL VELOCITY” of the force, since $du \div dt$ may be considered the velocity of the force at this instant, just as $ds \div dt$ is that of the point. The product of the force by its du will be called its *virtual moment*, reckoned + or – according as the direction from O to D is the same as that of the force or opposite.

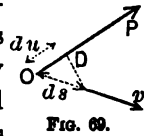

62. Prop. I.—*The virtual moment of a force equals the algebraic sum of those of its components.* Fig. 70. Take the

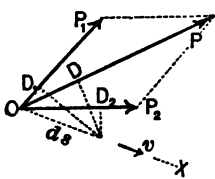

FIG. 70.

direction of ds as an axis X ; let P_1 and P_2 be components of P ; α_1 , α_2 , and α their angles with X . Then (§ 16) $P \cos \alpha = P_1 \cos \alpha_1 + P_2 \cos \alpha_2$. Hence $P(ds \cos \alpha) = P_1(ds \cos \alpha_1) + P_2(ds \cos \alpha_2)$. But $ds \cos \alpha =$ the projection of ds upon P , i.e., $= du$; $ds \cos \alpha_1 = du_1$, etc.; $\therefore Pdu = P_1 du_1 + P_2 du_2$. If in Fig. 70 α were $> 90^\circ$, evidently we would have $Pdu = -P_1 du_1 + P_2 du_2$, i.e., $P_1 du_1$ would then be negative, and OD_1 would fall behind O ; hence the definition of + and – in § 61. For any number of components the proof would be similar, and is equally applicable whether they are in one plane or not.

63. Prop. II.—*The sum of the virtual moments equals zero, for concurrent forces in equilibrium.*

* We should rather say “projected on the line of action of the force;” but the phrase used may be allowed, for brevity.

(If the forces are balanced, the material point is moving in a straight line if moving at all.) The resultant force is zero. Hence, from § 62, $P_1 du_1 + P_2 du_2 + \text{etc.} = 0$, having proper regard to sign, i.e., $\Sigma(P du) = 0$.

64. Prop. III.—*The sum of the virtual moments equals zero for any small displacement or motion of a rigid body in equilibrium under non-concurrent forces in a plane; all points of the body moving parallel to this plane.* (Although the kinds of motion of a given rigid body which are consistent with balanced non-concurrent forces have not yet been investigated, we may imagine any slight motion for the sake of the algebraic relations between the different du 's and forces.)

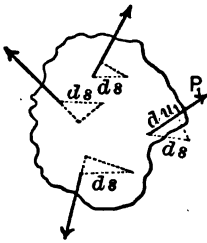

FIG. 71.

First, let the motion be a *translation*, all points of the body describing equal parallel lengths $= ds$. Take X parallel to ds ; let α , etc., be the angles of the forces with X . Then (§ 35) $\Sigma(P \cos \alpha) = 0$; $\therefore ds \Sigma(P \cos \alpha) = 0$; but $ds \cos \alpha_1 = du_1$; $ds \cos \alpha_2 = du_2$; etc.; $\therefore \Sigma(P du) = 0$. Q. E. D.

Secondly, let the motion be a *rotation* through a small angle $d\theta$ in the plane of the forces about any point O in that plane, Fig. 72. With O as a pole let ρ_1 be the radius-vector of the point of application of P_1 , and a_1 its lever-arm from O ; similarly for the other forces. In the rotation each point of application describes a small arc, ds_1, ds_2 , etc., proportional to ρ_1, ρ_2 , etc., since $ds_1 = \rho_1 d\theta$, $ds_2 = \rho_2 d\theta$, etc. From § 36, $P_1 a_1 + \text{etc.} = 0$; but from similar triangles $ds_1 : du_1 :: \rho_1 : a_1$; $\therefore a_1 = \rho_1 du_1 \div ds_1 = du_1 \div d\theta$; similarly $a_2 = du_2 \div d\theta$, etc. Hence we must have $[P_1 du_1 + P_2 du_2 + \dots] \div d\theta = 0$, i.e., $\Sigma(P du) = 0$. Q. E. D.

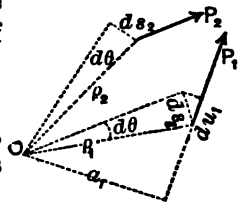

FIG. 72.

Now since any slight displacement or motion of a body may be conceived to be accomplished by a small translation followed by a rotation through a small angle, and since the fore-

going deals only with projections of paths, the proposition is established and is called the *Principle of Virtual Velocities*.

[A similar proof may be used for any slight motion whatever in space when a system of non-concurrent forces is balanced.] Evidently if the path (ds) of a point of application is perpendicular to the force, the virtual velocity (du), and consequently the virtual moment (Pdu) of the force are zero. Hence we may frequently make the displacement of such a character in a problem that one or more of the forces may be excluded from the summation of virtual moments.

65. Connecting-Rod by Virtual Velocities.—Let the effective steam-pressure P be the means, through the connecting-rod and crank (i.e., two links), of raising the weight G *very slowly*; neglect friction and the weight of the links themselves. Consider AB as *free* (see (b) in Fig. 73), BC also, at (c); let the

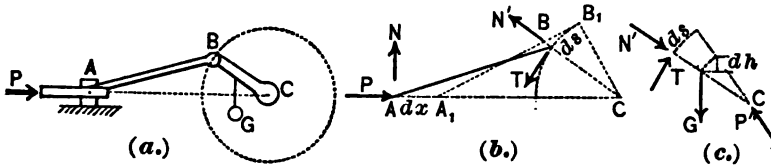

FIG. 73.

“small displacements” of both be *simultaneous* small portions of their ordinary motion in the apparatus. A has moved to A_1 through dx ; B to B_1 , through ds , a small arc; C has not moved. The forces acting on AB are P (steam-pressure), N (vertical reaction of guide), and N' and T (the tangential and normal components of the crank-pin pressure). Those on BC are N' and T (reversed), the weight G , and the oblique pressure of bearing P' . The motion being slow (or rather the acceleration being small), each of these two systems will be considered as balanced. Now put $\Sigma(Pdu) = 0$ for AB , and we have

$$Pdx + N \times 0 + N' \times 0 - Tds = 0. \quad (1)$$

For the simultaneous and corresponding motion of BC , $\Sigma(Pdu) = 0$ gives

$$N \times 0 + Tds - Gdh + P' \times 0 = 0, \dots (2)$$

dh being the vertical projection of G 's motion.

From (1) and (2) we have, easily, $Pdx - Gdh = 0, \dots (3)$

which is the same as we might have obtained by putting $\Sigma(Pdu) = 0$ for the two links together, regarded collectively as a free body, and describing a small portion of the motion they really have in the mechanism, viz., (Fig. 74.)

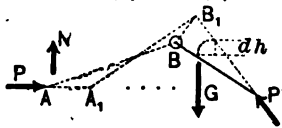

FIG. 74.

$$Pdx + N \times 0 - Gdh + P' \times 0 = 0. \dots (4)$$

We may therefore announce the—

66. Generality of the Principle of Virtual Velocities.—If any mechanism of flexible inextensible cords, or of rigid bodies jointed together, or both, at rest, or in motion with very small accelerations, be considered free collectively (or any portion of it), and all the external forces put in; then (disregarding mutual frictions) for a small portion of its prescribed motion, $\Sigma(Pdu)$ must = 0, in which the du , or virtual velocity, of each force, P , is the projection of the path of the point of application upon the force (the product, Pdu , being + or - according to § 61).

67. Example.—In the problem of § 65, having given the weight G , required the proper steam-pressure (effective) P to hold G in equilibrium, or to raise it uniformly, if already in motion, for a given position of the links. That is, Fig. 75, given $a, r, c, \alpha,$ and β , required the ratio $dh : dx$; for, from equation (3), § 65, $P = G(dh : dx)$. The projections of dx and ds upon AB will be equal, since $AB =$

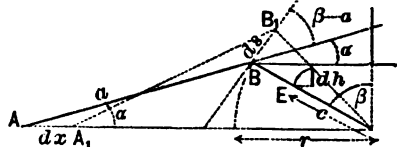

FIG. 75.

A_1B_1 , and makes an (infinitely) small angle with A_1B_1 , i.e., $dx \cos \alpha = ds \cos (\beta - \alpha)$. Also, $dh = (c : r)ds \sin \beta$.

Eliminating ds , we have,

$$\frac{dh}{dx} = \frac{c \sin \beta \cos \alpha}{r \cos(\beta - \alpha)}; \quad \therefore P = G \frac{c \sin \beta \cos \alpha}{r \cos(\beta - \alpha)}$$

68. When the acceleration of the parts of the mechanism is not practically zero, $\Sigma(Pdu)$ will not = 0, but a function of the masses and velocities to be explained in the chapter on Work, Energy, and Power. If friction occurs at moving joints, enough “free bodies” should be considered that no free body extend beyond such a joint; it will be found that this friction cannot be eliminated in the way in which T and N were, in § 65.

69. Additional Problems; to be solved by “virtual velocities.”

PROBLEM 1.—Find relations between the forces acting on a straight lever in equilibrium; also, on a bent lever.

PROBLEM 2.—When an ordinary copying-press is in equilibrium, find the relation between the force applied horizontally and tangentially at the circumference of the wheel, and the vertical resistance under the screw-shaft.

Solution.—Considering free the rigid body consisting of the wheel and screw-shaft, let R be the resistance at the point of the shaft (pointing along the axis of the shaft), and P the required horizontal tangential force at edge of wheel. Let radius of wheel be r . Besides R and P there are also acting on this body certain pressures, or “supporting forces,” consisting of the reactions of the collars, and reactions of the threads of nut against the threads of screw. Denote by s the “pitch” of the screw, i.e., the distance the shaft would advance for a full turn of the wheel. Then if we imagine the wheel to turn through a small angle $d\theta$, the corresponding advance, ds , of the shaft would be $\frac{s d\theta}{2\pi}$, from the proportion $s : ds :: 2\pi : d\theta$.

The path of the point of application of P would be a small portion of a helix, the projection of which on the line of P is $r d\theta$, while ds projects in its full length on the line of the force R . In the case of each of the other forces, however, the path of the point of application is *perpendicular* to the line of the force (which is normal to the rubbing surfaces, friction being disregarded). Hence, substituting in $\Sigma(P\dot{u}) = 0$, we have

$$+ P \cdot r d\theta - R \cdot ds + 0 + 0 = 0;$$

whence

$$P = \frac{ds}{r d\theta} \cdot R = \frac{s}{2\pi r} \cdot R.$$

CHAPTER III.

CURVILINEAR MOTION OF A MATERIAL POINT.

[Motion in a plane, only, will be considered in this chapter.]

70. Parallelogram of Motions.—It is convenient to regard the curvilinear motion of a point in a plane as compounded, or made up, of two independent rectilinear motions parallel respectively to two co-ordinate axes X and Y , as may be explained thus: Fig. 76. Consider the drawing-board CD as fixed, and let the head of a T -square move from A toward B along the edge according to any law whatever, while a pencil moves from M toward Q along the blade. The result is a curved line on the board, whose form depends on the character of the

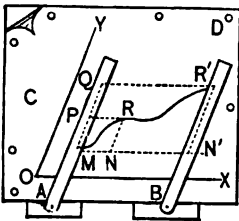

FIG. 76.

two X and Y component motions, as they may be called. If in a time t , the T -square head has moved an X distance = MN , and the pencil simultaneously a Y distance = MP , by completing the parallelogram on these lines, we obtain R , the position of the point on the board at the end of the time t . Similarly, at the end of the time t_1' we find the point at R' .

71. Parallelogram of Velocities.—Let the X and Y motions be *uniform*, required the resulting motion. Fig. 77. Let c_x and c_y be the constant uniform X and Y velocities. Then in any time, t , we have $x = c_x t$ and $y = c_y t$; whence we have, eliminating t , $x \div y = c_x \div c_y = \text{constant}$, i.e., x is proportional to y , i.e., the path is a straight line. Laying off $OA = c_x$, and $AB = c_y$, B is a point of the path, and OB is the distance described by the point in the first

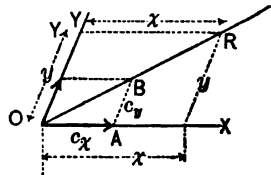

FIG. 77.

second. Since by similar triangles $\overline{OR} : x :: \overline{OB} : c_x$, we have also $\overline{OR} = \overline{OB} \cdot t$; hence the resultant motion is uniform, and its velocity, $\overline{OB} = c$, is the diagonal of the parallelogram formed on the two component velocities.

Corollary.—If the resultant motion is curved, the direction and velocity of the motion at any point will be given by the diagonal formed on the component velocities at that instant. The direction of motion is, of course, a tangent to the curve.

72. Uniformly Accelerated X and Y Motions.—The *initial velocities of both being zero*. Required the resultant motion.

Fig. 78. From § 56, eq. (2) (both c_x and c_y being = 0), we have $x = \frac{1}{2} p_x t^2$ and $y = \frac{1}{2} p_y t^2$, whence $x \div y = p_x \div p_y = \text{constant}$, and the resultant motion is in a straight line. Conceive lines laid off from O on X and Y to represent p_x and p_y to scale, and form a parallelogram on them.

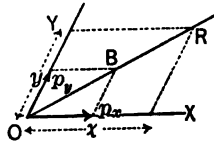

Fig. 78.

From similar triangles (OR being the distance described in the resultant motion in any time t), $\overline{OR} : x :: \overline{OB} : p_x$; $\therefore \overline{OR} = \frac{1}{2} \overline{OB} t^2$. Hence, from the form of this last equation, the resultant motion is uniformly accelerated, and its acceleration is $\overline{OB} = p$, (on the same scale as p_x and p_y).

This might be called the parallelogram of accelerations, but is really a parallelogram of forces, if we consider that a free material point, initially at rest at O , and acted on simultaneously by constant forces P_x and P_y (so that $p_x = P_x \div M$ and $p_y = P_y \div M$), must begin a uniformly accelerated rectilinear motion in the direction of the resultant force, having no initial velocity in any direction.

73. In general, considering the point hitherto spoken of as a *free material point*, under the action of one or more forces, in view of the foregoing, and of Newton's second law, given the initial velocity in amount and direction, the starting-point, the initial amounts and directions of the acting forces and the

laws of their variation if they are not constant, we can resolve them into a single X and a single Y force at any instant, determine the X and Y motions independently, and afterwards the resultant motion. The resultant force is never in the direction of the tangent to the path (except at a point of inflection). The relations which its amount and direction at any instant bear to the velocity, the rate of change of that velocity, and the radius of curvature of the path will appear in the next paragraph.

74. General Equations for the curvilinear motion of a material point in a plane.—The motion will be considered resulting from the composition of independent X and Y motions,

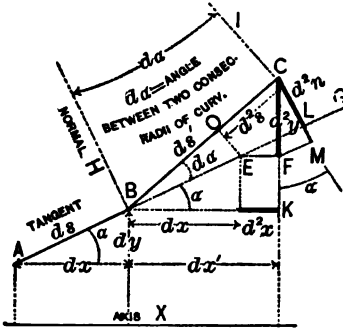

FIG. 79.

long ds , making $BE = ds$; then $EF = dx$, $CF = dy$, and $CO = ds$ (EO being perpendicular to BE). Also draw CL perpendicular to BG and call $CL d^2n$. Call the velocity of the X motion v_x , its acceleration p_x ; those of the Y motion, v_y and p_y . Then,

$$v_x = \frac{dx}{dt}; \quad v_y = \frac{dy}{dt}; \quad p_x = \frac{dv_x}{dt} = \frac{d^2x}{dt^2}; \quad \text{and} \quad p_y = \frac{dv_y}{dt} = \frac{d^2y}{dt^2}.$$

For the velocity along the curve (i.e., tangent) $v = ds \div dt$, we shall have, since $ds^2 = dx^2 + dy^2$,

$$v^2 = \left(\frac{ds}{dt}\right)^2 = \left(\frac{dx}{dt}\right)^2 + \left(\frac{dy}{dt}\right)^2 = v_x^2 + v_y^2. \quad \dots (1)$$

Hence v is the diagonal formed on v_x and v_y (as in § 71). Let p_t = the acceleration of v , i.e., the *tangential acceleration*.

then $p_t = d^2s \div dt^2$, and, since d^2s = the sum of the projections of EF and CF on BC , i.e., $d^2s = d^2x \cos \alpha + d^2y \sin \alpha$, we have

$$\frac{d^2s}{dt^2} = \frac{d^2x}{dt^2} \cos \alpha + \frac{d^2y}{dt^2} \sin \alpha; \text{ i.e., } p_t = p_x \cos \alpha + p_y \sin \alpha. \quad (2)$$

By **Normal Acceleration** we mean the rate of change of the velocity in the direction of the normal. In describing the element $AB = ds$, no progress has been made in the direction of the normal BH i.e., there is *no velocity* in the direction of the normal; but in describing BC (on account of the new direction of path) the point has progressed a distance CL (call it d^2n) in the direction of the old normal BH (though none in that of the new normal CI). Hence, just as the tang. acc.

$$= \frac{ds' - ds}{dt^2} = \frac{d^2s}{dt^2}, \text{ so the normal accel.} = \frac{CL - \text{zero}}{dt^2} = \frac{d^2n}{dt^2}.$$

It now remains to express this normal acceleration ($= p_n$) in terms of the X and Y accelerations. From the figure, $\overline{CL} = \overline{CM} - \overline{ML}$, i.e.,

$$d^2n = d^2y \cos \alpha - d^2x \sin \alpha \text{ \{since } EF = d^2x\};$$

$$\therefore \frac{d^2n}{dt^2} = \frac{d^2y}{dt^2} \cos \alpha - \frac{d^2x}{dt^2} \sin \alpha.$$

Hence $p_n = p_y \cos \alpha - p_x \sin \alpha. (3)$

The norm. acc. may also be expressed in terms of the tang. velocity v , and the radius of curvature r , as follows:

$$ds' = r d\alpha, \text{ or } d\alpha = ds' \div r; \text{ also } d^2n = ds' d\alpha, = ds'^2 \div r,$$

$$\text{i.e., } \frac{d^2n}{dt^2} = \left(\frac{ds'}{dt}\right)^2 \frac{1}{r}, \text{ or } p_n = \frac{v^2}{r} (4)$$

If now, Fig. 80, we resolve the forces $X = Mp_x$ and $Y = Mp_y$, which at this instant account for the X and Y accelerations (M = mass of the material point), into components along the tangent and normal to the curved path, we shall have, as *their equivalent*, a tangential force

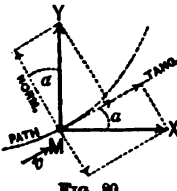

FIG. 80.

$$T = Mp_x \cos \alpha + Mp_y \sin \alpha,$$

and a normal force

$$N = Mp_v \cos \alpha - Mp_s \sin \alpha.$$

But [see equations (2), (3), and (4)] we may also write

$$T = Mp_t = M \frac{dv}{dt}; \quad \text{and} \quad N = Mp_n = M \frac{v^2}{r}. \quad (5)$$

Hence, if a free material point is moving in a curved path, the sum of the tangential components of the acting forces must equal (the mass) \times tang. accel.; that of the normal components, = (the mass) \times normal accel. = (mass) \times (square of veloc. in path) \div (rad. curv.).

It is evident, therefore, that the resultant force (= diagonal on T and N or on X and Y , Fig. 80) does not act along the tangent at any point, but toward the concave side of the path; unless $r = \infty$.

Radius of curvature.—From the line above eq. (4) we have $d^n n = ds'' \div r$; hence (line above eq. (3)), $ds'' \div r = d^2 y \cos \alpha - d^2 x \sin \alpha$; but $\cos \alpha = dx \div ds$, and $\sin \alpha = dy \div ds$,

$$\therefore \frac{ds''}{r} = d^2 y \frac{dx}{ds} - d^2 x \frac{dy}{ds}; \quad \text{or} \quad \frac{ds'' ds}{r} = dx^2 \left[\frac{dxd^2 y - dyd^2 x}{dx^2} \right];$$

$$\text{i.e.,} \quad \frac{ds'' ds}{r} = dx^2 d \left[\frac{dy}{dx} \right] = dx^2 d (\tan \alpha),$$

$$\therefore r = \left(\frac{ds'' ds}{dt^2} \right) \div \left[\left(\frac{dx}{dt} \right)^2 \frac{d \tan \alpha}{dt} \right];$$

$$\text{or,} \quad r = v^2 \div \left[v_x^2 \frac{d \tan \alpha}{dt} \right]. \quad \dots \quad (6)$$

which is equally true if, for v_x and $\tan \alpha$, we put v_y and $\tan (90^\circ - \alpha)$, respectively.

Change in the velocity square.—Since the tangential acceleration

$$\frac{dv}{dt} = p_t, \quad \text{we have} \quad ds \frac{dv}{dt} = p_t ds; \quad \text{i.e.,}$$

$$\frac{ds}{dt} dv = p_t ds, \quad \text{or} \quad v dv = p_t ds \quad \text{and} \quad \therefore \frac{v^2 - c^2}{2} = \int p_t ds. \quad (7)$$

having integrated between any initial point of the curve where $v = c$, and any other point where $v = v$. This is nothing more than equation (III.), of § 50.

75. **Normal Acceleration. Second Method.**—Fig. 81. Let C be the centre of curvature and $OD = 2r$. Let OB' be a portion of the osculatory parabola (vertex at O ; any osculatory curve will serve). When ds is described, the distance passed over in the direction of the normal is AB ; for $2ds$, it would be $A'B' = 4AB$ (i.e., as the square of OB' ; property of a parabola), and so on. Hence the motion along the normal is uniformly accelerated with initial velocity = 0, since the distance AB , varies as the *square of the time* (considering the motion along the curve of uniform velocity, so that the distance OB is directly as the time). If p_n denote the accel. of this uniformly accelerated motion, its initial velocity being = 0, we have (eq. 2, § 56) $\overline{AB} = \frac{1}{2}p_n dt^2$, i.e., $p_n = 2\overline{AB} \div dt^2$. But from the similar triangles ODB and OAB we have, $\overline{AB} : ds :: ds : 2r$, hence $2\overline{AB} = ds^2 \div r$, $\therefore p_n = ds^2 \div r dt^2 = v^2 \div r$.

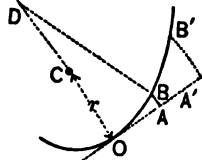

FIG. 81.

76. **Uniform Circular Motion. Centripetal Force.**—The velocity being constant, p_t must be = 0, and $\therefore T$ (or ΣT if there are several forces) must = 0. The resultant of all the forces, therefore, must be a normal force = $(Mc^2 \div r)$ = a constant (eq. 5, § 74). This is called the “deviating force,” or “centripetal force;” without it the body would continue in a straight line. Since forces always occur in pairs (§ 3), a “centrifugal force,” equal and opposite to the “centripetal” (one being the reaction of the other), will be found among the forces acting on the body to whose constraint the deviation of the first body from its natural straight course is due. For example, the attraction of the earth on the moon acts as a centripetal or deviating force on the latter, while the equal and opposite force *acting on the earth* may be called the centrifugal. If a small block moving on a smooth horizontal table is gradually turned from its straight course AB by a fixed circular guide, tangent to AB at B , the pressure of the guide against the block is the centripetal force $Mc^2 \div r$ directed *toward* the centre of curvature, while

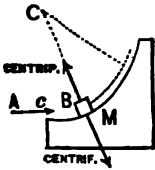

FIG. 82.

the centrifugal force $Mc^2 \div r$ is the pressure of the block against the guide, directed *away* from that centre. The centrifugal force, then, is never found among the forces acting on the body whose circular motion we are dealing with.

The Conical Pendulum, or governor-ball.—Fig. 82. If a material point of mass = $M = G \div g$, suspended on a cord of length = l , is to maintain a uniform circular motion in a horizontal plane, with a given radius r , under the action of gravity and the cord, required the velocity c to be given it. At B we have the body free. The only forces acting are G and the cord-tension P . The sum of their normal components,

i.e., ΣN , must = $Mc^2 \div r$, i.e., $P \sin \alpha = Mc^2 \div r$; but, since Σ (vert. comps.) = 0, $P \cos \alpha = G$. Hence $G \tan \alpha = Gc^2 \div gr$; $\therefore c = \sqrt{gr \tan \alpha}$. Let u = number of revolutions per unit of time, then $u = c \div 2\pi r = \sqrt{g} \div 2\pi \sqrt{h}$; i.e., is inversely proportional to the (vertical projection)[†] of the cord-length. The time of one revolution is = $1 \div u$.

Elevation of the outer rail on railroad curves (considerations of traction disregarded).—Consider a single car as a material point, and *free*, having a given velocity = c . P is the rail-pressure against the wheels. So long as the car follows the track the resultant R of P and G must point toward the centre of curvature and have a value = $Mc^2 \div r$. But $R = G \tan \alpha$, whence $\tan \alpha = c^2 \div gr$. If therefore the ties are placed at this angle α with the horizontal, the pressure will come upon the tread and not on the flanges of the wheels; in other words, the car will not leave the track. (This is really the same problem as the preceding)

Apparent weight of a body at the equator.—This is less than the true weight or attraction of the earth, on account of the uniform circular motion of the body with the earth in its diurnal rotation. If the body hangs from a spring-balance,

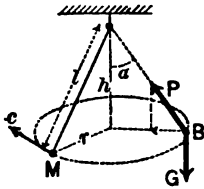

FIG. 82.

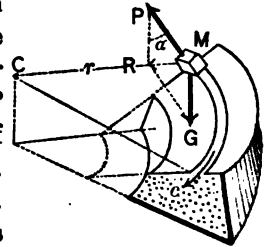

FIG. 84.

whose indication is G lbs. (apparent weight), while the true attraction is G' lbs., we have $G' - G = Mc^2 \div r$. For M we may use $G \div g$ (apparent values); for r about 20,000,000 ft.; for c , 25,000 miles in 24 hrs., reduced to feet per second. It results from this that G is $< G'$ by $\frac{1}{333}G'$ nearly, and (since $17^2 = 289$) hence if the earth revolved on its axis seventeen times as fast as at present, G would = 0, i.e., bodies would apparently have no weight, the earth's attraction on them being just equal to the necessary centripetal or deviating force necessary to keep the body in its orbit.

Centripetal force at any latitude.—If the earth were a homogeneous liquid, and at rest, its form would be spherical; but when revolving uniformly about the polar diameter, its form of relative equilibrium (i.e., no motion of the particles relatively to each other) is nearly ellipsoidal, the polar diameter being an axis of symmetry.

Lines of attraction on bodies at its surface do not intersect in a common point, and the centripetal force requisite to keep a suspended body in its orbit (a small circle of the ellipsoid), at any latitude β is the resultant, N , of the attraction or true weight G' directed (nearly) toward the centre, and of G the tension of the string. Fig. 85. G = the apparent weight, indicated by a spring-balance and MA is its line of action (plumb-line) normal to the ocean surface. Evidently the apparent weight, and consequently g , are less than the true values, since N must be perpendicular to the polar axis, while the true values themselves, varying inversely as the square of MC , decrease toward the equator, hence the apparent values decrease still more rapidly as the latitude diminishes. The following equation gives the apparent g for any latitude β , very nearly (units, foot and second):

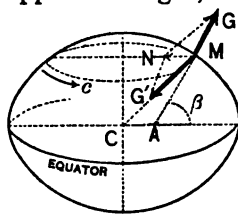

FIG. 85.

$$g = 32.1808 - 0.0821 \cos 2\beta.$$

(The value 32.2 is accurate enough for practical purposes. Since the earth's axis is really not at rest, but moving about

the sun, and also about the centre of gravity of the moon and earth, the form of the ocean surface is periodically varied, i.e., the phenomena of the tides are produced.

77. Cycloidal Pendulum.—This consists of a material point at the extremity of an imponderable, flexible, and inextensible cord of length = l , confined to the arc of a cycloid in a vertical plane by the cycloidal evolutes shown in Fig. 86. Let the oscillation begin (from rest) at A , a height = h above O

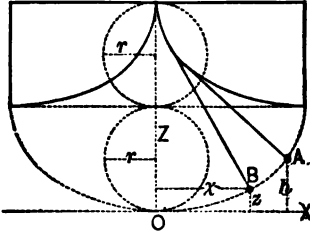

FIG. 86.

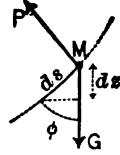

FIG. 87.

the vertex. On reaching any lower point, as B (height = z above O), the point has acquired some velocity v , which is at this instant increasing at some rate = p_t . Now consider the point free, Fig. 87; the forces acting are P the cord-tension, normal to path, and G the weight, at an angle φ with the path. From § 74, eq. (5), $\Sigma T = Mp_t$ gives

$$G \cos \varphi + P \cos 90^\circ = (G \div g)p_t; \therefore p_t = g \cos \varphi$$

Hence (eq. (7), § 74), $vdv = p_t ds$ gives

$$vdv = g \cos \varphi ds; \text{ but } ds \cos \varphi = -dz; \therefore vdv = -g dz.$$

Summing between A and B , we have

$$\left[\frac{1}{2}v^2 \right]_A^B = -g \int_h^z dz; \text{ or } v^2 = 2g(h - z);$$

the same as if it had fallen freely from rest through the height $h - z$. (This result evidently applies to any form of path when, besides the weight G , there is but one other force, and that always normal to the path.)

From $\Sigma N = Mv^2 \div r_1$, we have $P - G \sin \varphi = Mv^2 \div r_1$,

whence P , the cord-tension at any point, may be found (here r_1 = the radius of curvature at any point = length of straight portion of the cord).

To find the time of passing from A to O , a half-oscillation, substitute the above value of v^2 in $v = ds \div dt$, putting $ds^2 = dx^2 + dz^2$, and we have $dt^2 = (dx^2 + dz^2) \div [2g(h - z)]$. To find dx in terms of dz , differentiate the equation of the curve, which in this position is

$$x = r \text{ ver. sin.}^{-1}(z \div r) + \sqrt{2rz - z^2};$$

whence

$$dx = \frac{rdz}{\sqrt{2rz - z^2}} + \frac{(r - z)dz}{\sqrt{2rz - z^2}} = \frac{(2r - z)dz}{\sqrt{2rz - z^2}};$$

$$\therefore dx^2 = \left[\frac{2r}{z} - 1 \right] dz^2$$

(r = radius of the generating circle). Substituting, we have

$$dt = \sqrt{\frac{r}{g}} \cdot \frac{(-dz)}{\sqrt{hz - z^2}};$$

$$\therefore \int_A^O t = \sqrt{\frac{r}{g}} \int_0^h \frac{dz}{\sqrt{hz - z^2}} = \sqrt{\frac{r}{g}} \left[\text{ver. sin.}^{-1} \frac{z}{\frac{1}{2}h} \right]_0^h = \pi \sqrt{\frac{r}{g}}.$$

Hence the whole oscillation occupies a time = $\pi \sqrt{l \div g}$ (since $l = 4r$). This is independent of h , i.e., the oscillations are *isochronal*. This might have been proved by showing that p_t is proportional to OB measured along the curve; i.e., that the motion is *harmonic*. (§ 59, Prob. 2.)

78. Simple Circular Pendulum.—If the material point oscillates in the arc of a circle, Fig. 88, proceeding as in the preceding problem, we have finally, after integration by series, as the time of a full oscillation,

$$2 \int_A^O t = \pi \sqrt{\frac{l}{g}} \left[1 + \frac{1}{8} \cdot \frac{h}{l} + \frac{9}{256} \frac{h^2}{l^2} + \dots \right].$$

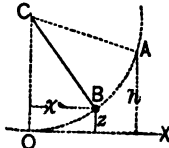

FIG. 88.

Hence for a small h the time is nearly $\pi \sqrt{l \div g}$, and the os-

cillations nearly isochronal. (For the Compound Pendulum, see § 117.)

79. Change in the Velocity Square.—From eq. (7), § 74, we have $\frac{1}{2}(v^2 - c^2) = \int p_t ds$. But, from similar triangles, du being the projection of any ds of the path upon the resultant force R at that instant, $Rdu = Tds$ (or, Prin. of Virt. Vels. § 62, $Rdu = Tds + N \times 0$). T and N are the tangential and normal components of R . Fig. 89. Hence, finally,

$$\frac{1}{2}Mv^2 - \frac{1}{2}Mc^2 = \int Rdu, \dots \dots (a)$$

for all elements of the curve between any two points. In general R is different in amount and direction for each ds of the path, but du is the distance through which R acts, in its own direction, while the body describes any ds ; Rdu is called the **work done** by R when ds is described by the body. The above equation is read: *The difference between the initial and final kinetic energy of a body = the work done by the resultant force in that portion of the path.*

(These phrases will be further spoken of in Chap. VI.)
Application of equation (a) to a planet in its orbit about the sun.—Fig. 90. Here the only force at any instant is the attraction of the sun $R = C \div u^2$ (see Prob. 3, § 59), where C is a constant and u the variable radius vector. As u diminishes, v increases, therefore dv and du have contrary signs; hence equation (a) gives (c being the velocity at some initial point O)

$$\frac{1}{2}Mv_1^2 - \frac{1}{2}Mc^2 = -C \int_{u_0}^{u_1} \frac{du}{u^2} = C \left[\frac{1}{u_1} - \frac{1}{u_0} \right]; (b)$$

$$\therefore v_1 = \sqrt{c^2 + \frac{2C}{M} \left[\frac{1}{u_1} - \frac{1}{u_0} \right]}, \text{ which is independent of the direction of the initial velocity } c.$$

NOTE.—If u_0 were = infinity, the last member of equation (b) would reduce to $C + u_1$, and is numerically the quantity called **potential** in the theory of electricity.

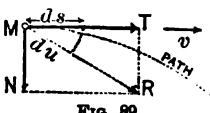

FIG. 89.

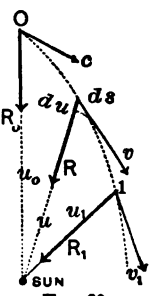

FIG. 90.

Application of eq. (a) to a projectile in vacuo.— G , the body's weight, is the only force acting, and therefore $= R$, while $M = G \div g$. Therefore equation (a) gives

$$\frac{G}{g} \cdot \frac{v_1^2 - c^2}{2} = G \int_0^{y_1} dy = Gy_1;$$

$\therefore v_1 = \sqrt{c^2 + 2gy_1}$, which is independent of the angle, α , of projection.

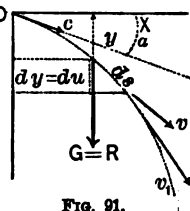

FIG. 91.

Application of equation (a) to a body sliding, without friction, on a fixed curved guide in a vertical plane; initial velocity = c at O .—Since there is some pressure at each point between the body and the guide, to consider the body *free* in space, we must consider the guide removed and that the body

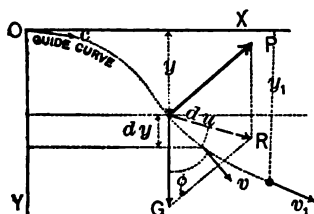

FIG. 92.

describes the given curve as a result of the action of the two forces, its weight G , and the pressure P , of the guide against the body. G is constant, while P varies from point to point, though always (since there is no friction) *normal to curve*.

At any point, R being the resultant of G and P , project ds upon R , thus obtaining du ; on G , thus obtaining dy ; on P , thus obtaining zero. But by the principle of virtual velocities (see § 62) we have $Rdu = Gdy + P \times \text{zero} = Gdy$, which substituted in eq. (a) gives

$$\frac{G}{g} \frac{1}{2} (v_1^2 - c^2) = \int_0^{y_1} Gdy = G \int_0^{y_1} dy = Gy_1; \therefore v_1 = \sqrt{c^2 + 2gy_1}$$

and therefore depends only on the *vertical distance* fallen through and the initial velocity, i.e., is *independent of the form of the guide*.

As to the value of P , the mutual pressure between the guide and body at any point, since ΣN must equal $Mv^2 \div r$, r being the variable radius of curvature, we have, as in § 77,

$$P - G \sin \varphi = Mv^2 \div r; \therefore P = G[\sin \varphi + (v^2 \div gr)].$$

As, in general, φ and r are different from point to point of

the path, P is not constant. (The student will explain how P may be negative on parts of the curve, and the meaning of this circumstance.)

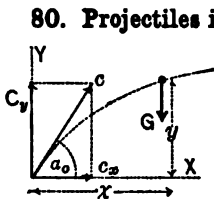

FIG. 28.

80. Projectiles in Vacuo.—A ball is projected into the air (whose resistance is neglected, hence the phrase *in vacuo*) at an angle $= \alpha_0$ with the horizontal; required its path; assuming it confined to a vertical plane. Resolve the motion into independent horizontal (X) and vertical (Y) motions, G , the weight,

the only force acting, being correspondingly replaced by its horizontal component $=$ zero, and its vertical component $= -G$. Similarly the initial velocity along $X = c_x = c \cos \alpha_0$, along $Y, = c_y = c \sin \alpha_0$. The X acceleration $= p_x = 0 \div M = 0$, i.e., the X motion is uniform, the velocity v_x remains $= c_x = c \cos \alpha_0$ at all points, hence, reckoning the time from O , at the end of any time t we have

$$x = c(\cos \alpha_0)t \dots \dots \dots (1)$$

In the Y motion, $p_y = (-G) \div M = -g$, i.e., it is uniformly retarded, the initial velocity being $c_y = c \sin \alpha_0$; hence, after any time t , the Y velocity will be (see § 56) $v_y = c \sin \alpha_0 - gt$, while the distance

$$y = c(\sin \alpha_0)t - \frac{1}{2}gt^2 \dots \dots \dots (2)$$

Between (1) and (2) we may eliminate t , and obtain as the equation of the trajectory or path

$$y = x \tan \alpha_0 - \frac{gx^2}{2c^2 \cos^2 \alpha_0}$$

For brevity put $c^2 = 2gh$, h being the ideal height due to the velocity c , i.e., $c^2 \div 2g$ (see § 53; if the ball were directed vertically upward, a height $h = c^2 \div 2g$ would be actually attained, α_0 being $= 90^\circ$), and we have

$$y = x \tan \alpha_0 - \frac{x^2}{4h \cos^2 \alpha_0} \dots \dots \dots (3)$$

This is easily shown to be the equation of a parabola, with its axis vertical.

The horizontal range.—Fig. 94. Putting $y = 0$ in equation (3), we obtain

$$x \left[\tan \alpha_0 - \frac{x}{4h \cos^2 \alpha_0} \right] = 0,$$

which is satisfied both by $x = 0$ (i.e., at the origin), and by $x = 4h \cos \alpha_0 \sin \alpha_0$. Hence the horizontal range for a given c and α_0 is $x_r = 4h \cos \alpha_0 \sin \alpha_0 = 2h \sin 2\alpha_0$.



FIG. 94.

For $\alpha_0 = 45^\circ$ this is a maximum (c remaining the same), being then $= 2h$. Also, since $\sin 2\alpha_0 = \sin (180^\circ - 2\alpha_0) = \sin 2(90^\circ - \alpha_0)$, therefore any two complementary angles of projection give the same horizontal range.

Greatest height of ascent; that is, the value of y maximum, $= y_m$.—Fig. 94. Differentiate (3), obtaining

$$\frac{dy}{dx} = \tan \alpha_0 - \frac{x}{2h \cos^2 \alpha_0},$$

which, put $= 0$, gives $x = 2h \sin \alpha_0 \cos \alpha_0$, and this value of x in (3) gives $y_m = h \sin^2 \alpha_0$.

(Let the student obtain this more simply by considering the Y motion separately.)

To strike a given point; c being given and α_0 required.—Let x' and y' be the co-ordinates of the given point, and α_0' the unknown angle of projection. Substitute these in equation (3), h being known $= c^2 \div 2g$, and we have

$$y' = x' \tan \alpha_0' - \frac{x'^2}{4h \cos^2 \alpha_0'}. \quad \text{Put } \cos^2 \alpha_0' = \frac{1}{1 + \tan^2 \alpha_0'}$$

and solve for $\tan \alpha_0'$, whence

$$\tan \alpha_0' = [2h \pm \sqrt{4h^2 - x'^2 - 4hy'}] \div x' \dots (4)$$

Evidently, if the quantity under the radical in (4) is negative, $\tan \alpha_0'$ is imaginary, i.e., the given point is *out of range* with the given velocity of projection $c = \sqrt{2g\bar{h}}$; if positive, $\tan \alpha_0'$ has two values, i.e., two trajectories may be passed through the point; while if it is zero, $\tan \alpha_0'$ has but one value.

The envelope, for all possible trajectories having the same

initial velocity c (and hence the same h); i.e., the curve tangent to them all, has but one point of contact with any one of them; hence each point of the envelope, Fig. 95, must have

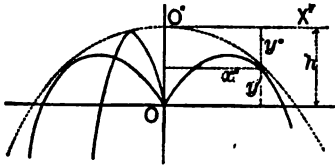

FIG. 95.

co-ordinates satisfying the condition, $4h^2 - x'^2 - 4hy' = 0$; i.e. (see equation (4)), that there is but one trajectory belonging to it. Hence, dropping primes, the equation of the envelope is $4h^2 - x^2 - 4hy = 0$. Now take O'' as a

new origin, a new horizontal axis X'' , and reckon y'' positive downwards; i.e., substitute $x = x''$ and $y = h - y''$. The equation now becomes $x''^2 = 4hy''$; evidently the equation of a parabola whose axis is vertical, whose vertex is at O'' , and whose parameter $= 4h =$ double the maximum horizontal range. O is therefore its focus.

The range on an inclined plane.—Fig. 96. Let OC be the trace of the inclined plane; its equation is $y = x \tan \beta$, which, combined with the equation of the trajectory (eq. 3), will give the co-ordinates of their intersection C . That is, substitute $y = x \tan \beta$ in (3) and solve for x , which will be the abscissa x_1 of C . This gives

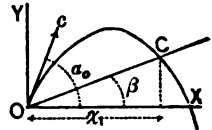

FIG. 96.

$$\frac{x_1}{4h \cos^2 \alpha} = \tan \alpha_0 - \tan \beta = \frac{\sin \alpha_0}{\cos \alpha_0} - \frac{\sin \beta}{\cos \beta} = \frac{\sin (\alpha_0 - \beta)}{\cos \alpha_0 \cos \beta};$$

$\therefore x_1 = 4h \cos \alpha_0 \sin (\alpha_0 - \beta) \div \cos \beta$, and the range \overline{OC} , which $= x_1 \div \cos \beta$, is $= (4h \div \cos^2 \beta) \cos \alpha_0 \sin (\alpha_0 - \beta)$. (5)

The maximum range on a given inclined plane, β , c (and $\therefore h$), remaining constant, while α_0 varies.—That is, required the value of α_0 which renders \overline{OC} a maximum. Differentiating (5) with respect to α_0 , putting this derivative $= 0$, we have $[4h \div \cos^2 \beta] [\cos \alpha_0 \cos (\alpha_0 - \beta) - \sin \alpha_0 \sin (\alpha_0 - \beta)] = 0$; whence $\cos [\alpha_0 + (\alpha_0 - \beta)] = 0$; i.e., $2\alpha_0 - \beta = 90^\circ$; or, $\alpha_0 = 45^\circ + \frac{1}{2}\beta$, for a maximum range. By substitution this maximum becomes known.

The velocity at any point of the path is $v = \sqrt{v_x^2 + v_y^2} =$

$\sqrt{c^2 - 2ctg \sin \alpha_0 + g^2 t^2}$ (see the first part of this § 80); while the *time of passage* from O to any point whose abscissa is x is $t = x \div c \cos \alpha_0$; obtained from equation (1). E.g., to reach the point B , Fig. 94, we put $x = x_r = 4h \sin \alpha \cos \alpha$, and obtain $t_r = 2c \sin \alpha \div g$. This will give the velocity at $B = \sqrt{c^2} = c$.

81. Actual Path of Projectiles.—Small jets of water, so long as they remain unbroken, give close approximations to parabolic paths, as also any small dense object, e.g., a ball of metal, having a moderate initial velocity. The course of a cannon-ball, however, with a velocity of 1200 to 1400 feet per second is much affected by the resistance of the air, the descending branch of the curve being much steeper than the ascending; see Fig. 96a. The equation of this curve has not yet been determined, but only the expression for the slope (i.e., $dy : dx$) at any point. See Professor Bartlett's *Mechanics*, § 151 (in which the body is a sphere having no motion of rotation). Swift rotation about an axis, as well as an unsymmetrical form with reference to the direction of motion, alters the trajectory still further, and may deviate it from a vertical plane. The presence of wind would occasion increased irregularity. See Johnson's *Encyclopædia*, article "Gunnery."

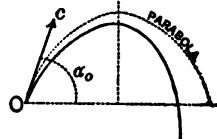

FIG. 96a.

82. Special Problem (imaginary; from Weisbach's *Mechanics*. *The equations are not homogeneous*).—Suppose a material point, mass = M , to start from the point O , Fig. 97, with a velocity = 9 feet per second along the $-Y$ axis, being subjected thereafter to a constant attractive X force, of a value $X = 12M$, and to a variable Y force increasing with the time (in seconds, reckoned from O),

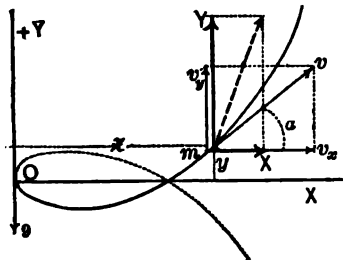

FIG. 97.

viz., $Y = 8Mt$. Required the path, etc. For the X motion we have $p_x = X \div M = 12$, and hence

$$\int_0^{v_x} dv_x = \int_0^t p_x dt = 12 \int_0^t dt; \text{ i.e., } v_x = 12t;$$

$$\text{and } \int_0^x dx = \int_0^t v_x dt; \text{ i.e., } x = 12 \int_0^t t dt = 6t^2. \quad (1)$$

For the Y motion $p_y = Y \div M = 8t$, $\therefore \int_{-9}^{v_y} dv_y = 8 \int_0^t t dt$;

$$\text{i.e., } v_y + 9 = 4t^2, \text{ and } \int_0^y dy = \int_0^t v_y dt;$$

$$\therefore y = 4 \int_0^t t^2 dt - 9 \int_0^t dt, \text{ or } y = \frac{4}{3}t^3 - 9t. \quad (2)$$

Eliminate t between (1) and (2), and we have, as the equation of the path,

$$y = \pm \frac{4}{3} \left(\frac{x}{6} \right)^{\frac{3}{2}} \mp 9 \left(\frac{x}{6} \right)^{\frac{1}{2}}, \quad \dots \quad (3)$$

which indicates a curve of the third order.

The velocity at any point is (see § 74, eq. (1))

$$v = \sqrt{v_x^2 + v_y^2} = 4t^2 + 9. \quad \dots \quad (4)$$

The length of curve measured from O will be (since $v = ds \div dt$)

$$s = \int_0^s ds = \int_0^t v dt = 4 \int_0^t t^2 dt + 9 \int_0^t dt = \frac{4}{3}t^3 + 9t. \quad (5)$$

The slope, $\tan \alpha$, at any point $= v_y \div v_x = (4t^2 - 9) \div 12t$,

$$\text{and } \therefore \frac{d \tan \alpha}{dt} = \frac{4t^2 + 9}{12t^2}. \quad \dots \quad (6)$$

The radius of curvature at any point (§ 74, eq. (6)), substituting $v_x = 12t$, also from (4) and (6), is

$$r = v^3 \div \left[v_x^3 \frac{d \tan \alpha}{dt} \right] = \frac{1}{12} [4t^2 + 9]^{\frac{3}{2}}, \quad \dots \quad (7)$$

and the normal acceleration $= v^3 \div r$ (eq. (4), § 74), becomes from (4) and (7) $p_n = 12$ (ft. per square second), a constant. Hence the centripetal or deviating force at any point, i.e., the

ΣN of the forces X and Y , is the same at all points, and = $Mv^2 \div r = 12M$.

From equation (3) it is evident that the curve is symmetrical about the axis X . Negative values of t and s would apply to points on the dotted portion in Fig. 97, since the body may be considered as having started at any point whatever, so long as all the variables have their proper values for that point.

(Let the student determine how the conditions of this motion could be approximated to experimentally.)

83. Relative and Absolute Velocities.—Fig. 98. Let M be a material point having a uniform motion of velocity v_2 along a straight groove cut in the deck of a steamer, which itself has a uniform motion of translation, of velocity v_1 , over the bed of a river. In one second M advances a distance v_2 along the groove, which simultaneously has moved a distance $v_1 = AB$ with the vessel. The absolute path of M during the second is evidently w (the diagonal formed on v_1 and v_2), which may therefore be called the *absolute velocity* of the body (considering the bed of the river as fixed); while v_2 is its *relative velocity*, i.e., relative to the vessel. If the motion of the vessel is not one of translation, the construction still holds good for an instant of time, but v_1 is then the velocity of that point of the deck over which M is passing at this instant, and v_2 is M 's velocity relative to that point alone.

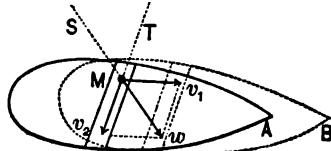

FIG. 98.

Conversely, if M be moving over the deck with a given absolute velocity = w , v_1 being that of the vessel, the relative velocity v_2 may be found by resolving w into two components, one of which shall be v_1 ; the other will be v_2 .

If w is the absolute velocity and direction of the *wind*, the *vane* on the mast-head will be parallel to MT , i.e., to v_2 the relative velocity; while if the vessel be rolling and the mast-head therefore describing a sinuous path, the direction of the vane varies periodically.

Evidently the effect of the wind on the sails, if any, will depend on v , the relative, and not directly on w the absolute, velocity. Similarly, if w is the velocity of a jet of water, and v , that of a water-wheel channel, which the water is to enter without sudden deviation, or impact, the channel-partition should be made tangent to v , and not to w .

Again, the *aberration of light* of the stars depends on the same construction; v , is the absolute velocity of a locality of the earth's surface (being practically equal to that of the centre); w is the absolute direction and velocity of the light from a certain star. To see the star, a telescope must be directed along MT , i.e., parallel to v , the relative velocity; just as in the case of the moving vessel, the groove must have the direction MT , if the moving material point, having an absolute velocity w , is to pass down the groove without touching its sides. Since the velocity of light = 192,000 miles per second = w , and that of the earth in its orbit = 19 miles per second = v , the angle of aberration SMT , Fig. 98, will not exceed 20 seconds of arc; while it is zero when w and v are parallel.

Returning to the wind and sail-boat,* it will be seen from Fig. 98 that when v , = or even $> w$, it is still possible for v , to be of such an amount and direction as to give, on a sail properly placed, a small wind-pressure, having a small fore-and aft component, which in the case of an ice-boat may exceed the small fore-and-aft resistance of such a craft, and thus v , will be still further increased; i.e., an ice-boat may sometimes travel faster than the wind which drives it. This has often been proved experimentally on the Hudson River.

* See § 571 for the mechanics of the sail-boat.

CHAPTER IV.

MOMENT OF INERTIA.

[NOTE.—For the propriety of this term and its use in Mechanics, see §§ 114, 216, and 220; for the present we deal only with the geometrical nature of these two kinds of quantity.]

85. Plane Figures.—Just as in dealing with the centre of gravity of a plane figure (§ 23), we had occasion to sum the series $\int z dF$, z being the distance of any element of area, dF , from an axis; so in subsequent chapters it will be necessary to know the value of the series $\int z^2 dF$ for plane figures of various shapes referred to various axes. This summation $\int z^2 dF$ of the products arising from multiplying each elementary area of the figure by the *square* of its distance from an axis is called the *moment of inertia of the plane figure with respect to the axis in question*; its symbol will be I . If the axis is perpendicular to the plane of the figure, it may be named the *polar mom. of inertia* (§ 94); if the axis lies in the plane, the *rectangular mom. of inertia* (§§ 90–93). Since the I of a plane figure evidently consists of *four dimensions of length*, it may always be resolved into two factors, thus $I = Fk^2$, in which F = total area of the figure, while $k = \sqrt{I \div F}$, is called the *radius of gyration*, because if all the elements of area were situated at the *same* radial distance, k , from the axis, the moment of inertia would still be the same, viz.,

$$I = \int k^2 dF = k^2 \int dF = Fk^2.$$

86. Rigid Bodies.—Similarly, in dealing with the rotary motion of a rigid body, we shall need the sum of the series $\int \rho^2 dM$, meaning the summation of the products arising from multiplying the mass dM of each elementary volume dV of a

rigid body by the square of its distance from a specified axis. This will be called the *moment of inertia of the body with respect to the particular axis mentioned* (often indicated by a subscript), and will be denoted by I . As before, it can often be conveniently written Mk^2 , in which M is the whole mass, and k its "radius of gyration" for the axis used, k being $= \sqrt{I \div M}$. If the body is *homogeneous*, the heaviness, γ , of all its particles will be the same, and we may write

$$I = \int \rho^2 dM = (\gamma \div g) \int \rho^2 dV = (\gamma \div g) V k^2.$$

87. If the body is a homogeneous plate of an *infinitely small thickness* $= \tau$, and of area $= F$, we have $I = (\gamma \div g) \int \rho^2 dV = (\gamma \div g) \tau \int \rho^2 dF$; i.e., $= (\gamma \div g) \times \text{thickness} \times \text{mom. inertia of the plane figure}$.

88. Two Parallel Axes. Reduction Formula.—Fig. 99. Let

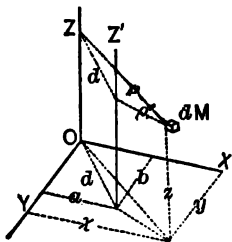

FIG. 99.

Z and Z' be two parallel axes. Then $I_z = \int \rho^2 dM$, and $I_{z'} = \int \rho'^2 dM$. But d being the distance between the axes, so that $a^2 + b^2 = d^2$, we have $\rho'^2 = (x - a)^2 + (y - b)^2 = (x^2 + y^2) + d^2 - 2ax - 2by$, and \therefore

$$I_{z'} = \int \rho'^2 dM = \int (x^2 + y^2) dM + \int d^2 dM - 2 \int ax dM - 2 \int by dM. \quad (1)$$

But $\int \rho^2 dM = I_z$, $\int dM = M$, and from the theory of the centre of gravity (see § 23, eq. (1), knowing that $dM = \gamma dV \div g$, and \therefore that $[\int \gamma dV] \div g = M$) we have $\int ax dM = M\bar{x}$ and $\int by dM = M\bar{y}$; hence (1) becomes

$$I_{z'} = I_z + M(d^2 - 2a\bar{x} - 2b\bar{y}), \dots \quad (2)$$

in which a and b are the x and y of the axis Z' ; \bar{x} and \bar{y} refer to the centre of gravity of the body. If Z is a gravity-axis (call it g), both \bar{x} and $\bar{y} = 0$, and (2) becomes

$$I_{z'} = I_g + Md^2 \dots \text{ or } k_{z'}^2 = k_g^2 + d^2 \dots \quad (3)$$

It is therefore evident that the mom. of inertia about a gravity-axis is smaller than about any other *parallel* axis.

Eq. (3) includes the particular case of a *plane figure*, by

writing area instead of mass, i.e., when Z (now g) is a gravity-axis,

$$I_g = I_o + Fd^2. \dots \dots \dots (4)$$

89. Other Reduction Formulæ; for Plane Figures.—(The axes here mentioned lie in the plane of the figure.) For *two sets of rectangular axes*, having the *same origin*, the following holds good. Fig. 100. Since

$$I_x = \int y^2 dF, \text{ and } I_y = \int x^2 dF,$$

we have $I_x + I_y = \int (x^2 + y^2) dF$.

Similarly, $I_u + I_v = \int (v^2 + u^2) dF$.

But since the x and y of any dF have the same hypotenuse as the u and v , we have $v^2 + u^2 = x^2 + y^2$; $\therefore I_x + I_y = I_u + I_v$.

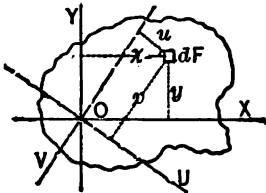

FIG. 100.

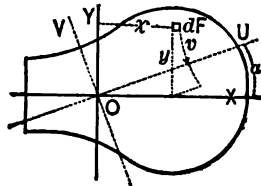

FIG. 100a.

Let X be an axis of symmetry; then, given I_x and I_y (O is anywhere on X), required I_v , U being an axis through O and making any angle α with X .

$$I_v = \int v^2 dF = \int (y \cos \alpha - x \sin \alpha)^2 dF; \text{ i.e.,}$$

$$I_v = \cos^2 \alpha \int y^2 dF - 2 \sin \alpha \cos \alpha \int xy dF + \sin^2 \alpha \int x^2 dF.$$

But since the area is symmetrical about X , in summing up the products $xy dF$, for every term $x(+y) dF$, there is also a term $x(-y) dF$ to cancel it; which gives $\int xy dF = 0$. Hence

$$I_v = \cos^2 \alpha I_x + \sin^2 \alpha I_y.$$

The student may easily prove that if two distances a and b be set off from O on X and Y respectively, made inversely proportional to $\sqrt{I_x}$ and $\sqrt{I_y}$, and an ellipse described on a and b as semi-axes; then the moments of inertia of the figure about

any axes through O are inversely proportional to the squares of the corresponding semi-diameters of this ellipse; called therefore the *Ellipse of Inertia*. It follows therefore that the moments of inertia about *all gravity-axes* of a circle, or a regular polygon, are equal; since their ellipse of inertia must be a circle. Even if the plane figure is not symmetrical, an "ellipse of inertia" can be located at any point, and has the properties already mentioned; its axes are called the *principal axes* for that point.

90. The Rectangle.—*First, about its base.* Fig. 101. Since all points of a strip parallel to the base have the same co-ordinate, z , we may take the area of such a strip for $dF = b dz$;

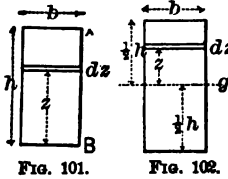

$$\therefore I_B = \int_0^h z^2 dF = b \int_0^h z^2 dz = \frac{1}{3} b \left[z^3 \right]_0^h = \frac{1}{3} b h^3.$$

Secondly, about a gravity-axis parallel to base.

$$dF = b dz \therefore I_g = \int_{-h}^{+h} z^2 dF = b \int_{-h}^{+h} z^2 dz = \frac{1}{3} b h^3.$$

Thirdly, about any other axis in its plane. Use the results already obtained in connection with the reduction-formulae of §§ 88, 89.

90a. The Triangle.—*First, about an axis through the vertex and parallel to the base;* i.e., I_V in Fig. 103. Here the length of the strip is variable; call it y . From similar triangles

$$y = (b \div h)z;$$

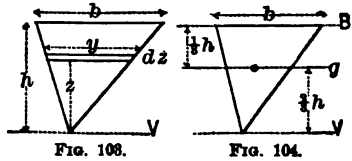

$$\therefore I_V = \int z^2 dF = \int z^2 y dz = (b \div h) \int_0^h z^3 dz = \frac{1}{4} b h^3.$$

Secondly, about g, a gravity-axis parallel to the base. Fig. 104. From § 88, eq. (4), we have, since $F = \frac{1}{2} b h$ and

$$d = \frac{2}{3} h, I_g = I_V - F d^2 = \frac{1}{4} b h^3 - \frac{1}{2} b h \cdot \frac{4}{9} h^2 = \frac{1}{36} b h^3.$$

Thirdly, Fig. 104, about the base; $I_B = ?$ From § 88, eq. (4), $I_B = I_o + Fd^2$, with $d = \frac{1}{3}h$; hence

$$I_B = \frac{1}{36}bh^3 + \frac{1}{3}bh \cdot \frac{1}{9}h^2 = \frac{1}{18}bh^3.$$

91. The Circle.—About any diameter, as g , Fig. 105. Polar co-ordinates, $I_o = \int z^2 dF$. Here we take $dF =$ area of an elementary rectangle $= \rho d\varphi \cdot d\rho$, while $z = \rho \sin \varphi$.

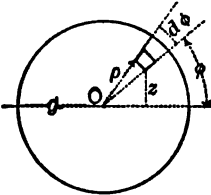

FIG. 105.

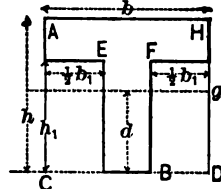

FIG. 106.

$$\begin{aligned} I_o &= \int \int (\rho \sin \varphi)^2 \rho d\varphi d\rho = \int_0^{2\pi} \left[\sin^2 \varphi d\varphi \int_0^r \rho^3 d\rho \right] \\ &= \frac{r^4}{4} \int_0^{2\pi} \sin^2 \varphi d\varphi = \frac{r^4}{4} \int_0^{2\pi} \frac{1}{2}(1 - \cos 2\varphi) d\varphi \\ &= \frac{r^4}{4} \int_0^{2\pi} \left[\frac{1}{2} d\varphi - \frac{1}{4} \cdot \cos 2\varphi d(2\varphi) \right] \\ &= \frac{1}{4} r^4 \left[\frac{1}{2} \varphi - \frac{1}{4} \sin 2\varphi \right] \\ &= \frac{1}{4} r^4 \left[\left(\frac{2\pi}{2} - 0 \right) - (0 - 0) \right]. \quad \text{i.e., } I_o = \frac{1}{4} \pi r^4. \end{aligned}$$

92. Compound Plane Figures.—Since $I = \int z^2 dF$ is an infinite series, it may be considered as made up of separate groups or subordinate series, combined by algebraic addition, corresponding to the subdivision of the compound figure into component figures, each subordinate series being the moment of inertia of one of these component figures; but these separate moments *must all be referred to the same axis*. It is convenient to remember that the (rectangular) I of a plane figure remains unchanged if we conceive some or all of its elements shifted any distance parallel to the axis of reference. E.g., in Fig. 106, the sum of the I_B of the rectangle CE , and that of FD is = to the I_B of the imaginary rectangle

formed by shifting one of them parallel to B , until it touches the other; i.e., I_B of $CE + I_B$ of $FD = \frac{1}{3}bh_1^3$ (§ 90). Hence the I_B of the Υ shape in Fig. 106 will be = I_B of rectangle $AD - I_B$ of rect. $CE - I_B$ of rect. FD .

That is, I_B of $\Upsilon = \frac{1}{3}[bh^3 - b_1h_1^3] \dots$ (§ 90). . . (1)

About the gravity-axis, g , Fig. 106. To find the distance d from the base to the centre of gravity, we may make use of eq. (3) of § 23, writing areas instead of volumes, or, experimentally, having cut the given shape out of sheet-metal or card-board, we may balance it on a knife-edge. Supposing d to be known by some such method, we have, from eq. (4) of § 88, since the area $F = bh - b_1h_1$, $I_g = I_B - Fd^2$;

i.e., $I_g = \frac{1}{3}[bh^3 - b_1h_1^3] - (bh - b_1h_1)d^2 \dots$ (2)

The double- Υ (or Ξ), and the box forms of Fig. 106a, if

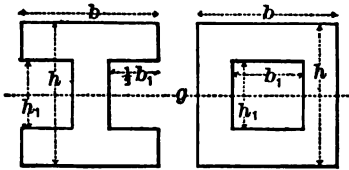

Fig. 106a.

symmetrical about the gravity-axis g , have moments of inertia alike in form. Here the gravity-axis (parallel to base) of the compound figure is also a gravity-axis (parallel to base) of each

of the two component rectangles, of dimensions b and h , b_1 and h_1 , respectively.

Hence by algebraic addition we have (§ 90), for either compound figure,

$$I_g = \frac{1}{12}[bh^3 - b_1h_1^3] \dots \dots \dots (3)$$

(If there is no axis of symmetry parallel to the base we must proceed as in dealing with the Υ -form.) Similarly for the ring,

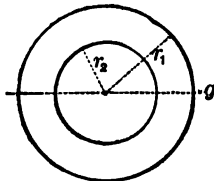

Fig. 107.

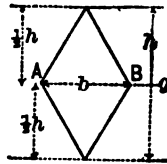

Fig. 108.

Fig. 107, or space between two concentric circumferences, we have, about any diameter or g (§ 91),

$$I_g = \frac{1}{4}\pi(r_1^4 - r_2^4) \dots \dots \dots (4)$$

The *rhombus* about a gravity-axis, g , perpendicular to a diagonal, Fig. 108.—This axis divides the figure into two equal triangles, *symmetrically placed*, hence the I_g of the rhombus equals double the moment of inertia of one triangle about its base; hence (§ 90a)

$$I_g = 2 \cdot \frac{1}{12} b \left(\frac{1}{2}h\right)^3 = \frac{1}{48} bh^3. \dots \dots (5)$$

(The result is the same, if either vertex, or both, be shifted any distance parallel to AB .)

For practice, the student may derive results for the *trapezoid*; for the forms in Fig. 106, when the inner corners are rounded into equal quadrants of circles; for the double- \top , when the lower flanges are shorter than the upper; for the regular polygons, etc.

93. If the plane figure be bounded, wholly or partially, by curves, it may be subdivided into an infinite number of strips, and the moments of inertia of these (referred to the desired axis) added by integration, *if the equations of the curves are known*; if not, Simpson's Rule, for a finite even number of strips, of equal width, may be employed for an approximate result. If these strips are parallel to the axis, the I of any one strip = its length \times its width \times square of distance from axis; while if perpendicular to, and *terminating in*, the axis, its $I = \frac{1}{3}$ its width \times cube of its length (see § 90).

A graphic method of determining the moment of inertia of any irregular figure will be given in a subsequent chapter.

94. **Polar Moment of Inertia of Plane Figures** (§ 85).—Since the axis is now perpendicular to the plane of the figure, intersecting it in a point, O , the distances of the elements of area will all *radiate* from this point, and would better be denoted by ρ instead of z ;

hence, Fig. 109, $\int \rho^2 dF$ is the polar moment of inertia of any plane figure about a specified point O ; this may be denoted by I_p . But $\rho^2 = x^2 + y^2$, for each dF ; hence

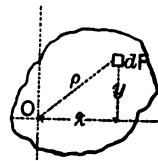

FIG. 109.

$$I_p = \int (x^2 + y^2) dF = \int x^2 dF + \int y^2 dF = I_y + I_x.$$

i.e., the polar moment of inertia about any given point in the plane equals the sum of the rectangular moments of inertia about any two axes of the plane figure, which intersect at right angles in the given point. We have therefore for the circle about its centre

$$I_p = \frac{1}{2}\pi r^4 + \frac{1}{2}\pi r^4 = \pi r^4;$$

For a ring of radii r_1 and r_2 ,

$$I_p = \frac{1}{2}\pi(r_1^4 - r_2^4);$$

For the rectangle about its centre,

$$I_p = \frac{1}{12}bh^3 + \frac{1}{12}hb^3 = \frac{1}{12}bh(b^2 + h^2);$$

For the square, this reduces to

$$I_p = \frac{1}{3}b^4.$$

(See §§ 90 and 91.)

95. Slender, Prismatic, Homogeneous Rod.—Returning to the moment of inertia of rigid bodies, or solids, we begin with that

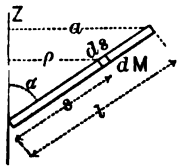

FIG. 110.

of a material line, as it might be called, about an axis through its extremity making some angle α with the rod. Let l = length of the rod, F its cross-section (very small, the result being strictly true only when $F = 0$). Subdivide the rod into an infinite number of small prisms, each having F as a base, and an altitude = ds . Let γ = the heaviness of the material; then the mass of an elementary prism, or dM , = $(\gamma \div g)Fds$, while its distance from the axis Z is $\rho = s \sin \alpha$. Hence the moment of inertia of the rod with respect to Z as an axis is

$$I_Z = \int \rho^2 dM = (\gamma \div g)F \sin^2 \alpha \int_0^l s^2 ds = \frac{1}{3}(\gamma \div g)F l^3 \sin^2 \alpha.$$

But $\gamma F l \div g$ = mass of rod and $l \sin \alpha = a$, the distance of the further extremity from the axis; hence $I_Z = \frac{1}{3}M a^2$ and the radius of gyration, or k , is found by writing $\frac{1}{3}M a^2 = M k^2$; $\therefore k^2 = \frac{1}{3}a^2$, or $k = \sqrt{\frac{1}{3}}a$ (see § 86). If $\alpha = 90^\circ$, $a = l$.

96. Thin Plates. Axis in the Plate.—Let the plates be homogeneous and of small constant thickness = τ . If the surface of

the plate be = F , and its heaviness γ , then its mass = $\gamma F\tau \div g$. From § 87 we have for the plate, about any axis,

$$I = (\gamma \div g)\tau \times \text{mom. of inertia of the plane figure formed by the shape of the plate.} \dots \dots \dots (1)$$

Rectangular plate. Gravity-axis parallel to base.—Dimensions b and h . From eq. (1) and § 90 we have

$$I_o = (\gamma \div g)\tau \cdot \frac{1}{12}bh^3 = (\gamma bh\tau \div g)\frac{1}{12}h^3 = \frac{1}{12}Mh^3; \therefore k^2 = \frac{1}{12}h^2.$$

Similarly, if the base is the axis, $I_B = \frac{1}{12}Mh^3$, $\therefore k^2 = \frac{1}{12}h^2$.

Triangular plate. Axis through vertex parallel to base.—From eq. (1) and § 90a, dimensions being b and h ,

$$I_v = (\gamma \div g)\tau \frac{1}{4}bh^3 = (\gamma \frac{1}{2}bh\tau \div g)\frac{1}{3}h^3 = \frac{1}{6}Mh^3; \therefore k^2 = \frac{1}{6}h^2.$$

Circular plate, with any diameter as axis.—From eq. (1) and § 91 we have

$$I_o = (\gamma \div g)\tau \frac{1}{2}\pi r^4 = (\gamma \pi r^2 \tau \div g)\frac{1}{2}r^2 = \frac{1}{2}Mr^2; \therefore k^2 = \frac{1}{2}r^2.$$

97. Plates or Right Prisms of any Thickness (or Altitude). Axis Perpendicular to Surface (or Base).—As before, the solid is

homogeneous, i.e., of constant heaviness γ ; let the altitude = h . Consider an elementary prism, Fig. 111, whose length is parallel to the axis of reference Z . Its altitude = h = that of the whole solid; its base = dF = an element of F the area of the base of solid; and each point of it has the same ρ . Hence we may take its mass, = $\gamma h dF \div g$, as the dM in summing the series

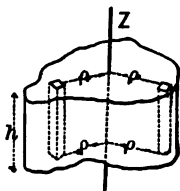

FIG. 111.

$$I_z = \int \rho^2 dM; \\ \therefore I_z = (\gamma h \div g) \int \rho^2 dF \\ = (\gamma h \div g) \times \text{polar mom. of inertia of base.} \dots (2)$$

By the use of eq. (2) and the results in § 94 we obtain the following:

Circular plate, or right circular cylinder, about the geometrical axis. r = radius, h = altitude.

$$I_o = (\gamma h \div g)\frac{1}{2}\pi r^4 = (\gamma h \pi r^2 \div g)\frac{1}{2}r^2 = \frac{1}{2}Mr^2; \therefore k^2 = \frac{1}{2}r^2.$$

Right parallelepiped or rectangular plate.—Fig. 112,

$$I_o = (\gamma h \div g)\frac{1}{12}bb(b_1^2 + b^2) = M\frac{1}{12}d^2; \therefore k^2 = \frac{1}{12}d^2.$$

For a *hollow cylinder*, about its geometric axis,
 $I_g = (\gamma h + g) \frac{1}{2} \pi (r_1^4 - r_2^4) = \frac{1}{2} M (r_1^2 + r_2^2)$; $\therefore k^2 = \frac{1}{2} (r_1^2 + r_2^2)$.

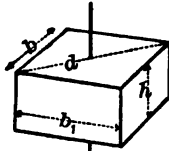

FIG. 112.

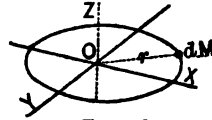

FIG. 113.

98. Circular Wire.—Fig. 113 (perspective). Let Z be a gravity-axis perpendicular to the plane of the wire; X and Y lie in this plane, intersecting at right angles in the centre O . The wire is homogeneous and of constant (small) cross-section. Since, referred to Z , each dM has the same $\rho = r$, we have $I_Z = \int r^2 dM = Mr^2$. Now I_X must equal I_Y , and (§ 94) their sum = I_Z ,

$$\therefore I_X, \text{ or } I_Y, = \frac{1}{2} Mr^2, \quad \text{and} \quad k_X^2, \text{ or } k_Y^2 = \frac{1}{2} r^2.$$

99. Homogeneous Solid Cylinder, about a diameter of its base.
 —Fig. 114. $I_X = ?$ Divide the cylinder into an infinite number of laminæ, or thin plates, parallel to the base. Each is some distance z from X , of thickness dz , and of radius r (constant). In each draw a gravity-axis (of its own) parallel to X . We may now obtain the I_X of the whole cylinder by adding the I_X 's of all the laminæ. The I_g of any one lamina (§ 96, circular plate) = its mass $\times \frac{1}{2} r^2$; hence its I_X (eq. (3), § 88) = its $I_g + (\text{its mass}) \times z^2$. Hence for the whole cylinder

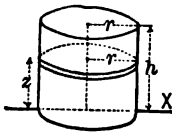

FIG. 114.

$$\begin{aligned} I_X &= \int_0^h [(\gamma dz \pi r^2 \div g) (\frac{1}{2} r^2 + z^2)] \\ &= (\pi r^2 \gamma \div g) \left[\frac{1}{2} r^2 \int_0^h dz + \int_0^h z^2 dz \right]; \end{aligned}$$

$$\text{i.e., } I_X = (\pi r^2 h \gamma \div g) (\frac{1}{2} r^2 + \frac{1}{3} h^2) = M (\frac{1}{2} r^2 + \frac{1}{3} h^2).$$

100. Let the student prove (1) that if Fig. 114 represent any right prism, and k_F denote the radius of gyration of any one lamina, referred to its gravity-axis parallel to X , then the I_X of whole prism = $M(k_F^2 + \frac{1}{3} h^2)$; and (2) that the moment

of inertia of the cylinder about a gravity-axis parallel to the base is $= M(\frac{1}{2}r^2 + \frac{1}{12}h^2)$.

101. **Homogeneous Right Cone.**—Fig. 115. *First*, about an axis V , through the vertex and parallel to the base. As before, divide into laminæ parallel to the base. Each is a circular thin plate, but its radius, x , is not $= r$, but, from proportion, is $x = (r \div h)z$.

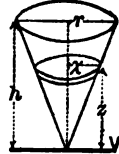

FIG. 115.

The I of any lamina referred to its own gravity-axis parallel to V is (§ 96) = (its mass) $\times \frac{1}{2}x^2$, and its I_V (eq. (3), § 88) is \therefore = its mass $\times \frac{1}{2}x^2 +$ its mass $\times z^2$.

Hence for the whole cone,

$$I_V = \int_0^h (\pi x^2 dz \div g) [\frac{1}{2}x^2 + z^2]$$

$$= \frac{\gamma \pi r^3}{gh^3} \left[\frac{1}{4} \cdot \frac{r^2}{h^2} + 1 \right] \int_0^h z^2 dz = M \frac{3}{20} [r^2 + 4h^2].$$

Secondly, about a gravity-axis parallel to the base.—From eq. (3), § 88, with $d = \frac{3}{2}h$ (see Prob. 7, § 26), and the result just obtained, we have $I = M \frac{3}{10} [r^2 + \frac{1}{2}h^2]$.

Thirdly, about its geometrical axis, Z .—Fig. 116. Since the axis is perpendicular to each circular lamina through the centre, its I_Z (§ 97) is

$$= \text{its mass} \times \frac{1}{2}(\text{rad.})^2 = (\gamma \pi x^2 dz \div g) \frac{1}{2}x^2.$$

Now $x = (r \div h)z$, and hence for the whole cone

$$I_Z = \frac{1}{2}(\gamma \pi r^2 \div gh^3) \int_0^h z^3 dz = (\frac{1}{8} \pi r^2 h \gamma \div g) \frac{1}{4} r^2 = M \frac{3}{16} r^2.$$

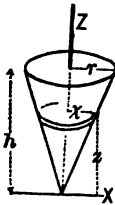

FIG. 116.

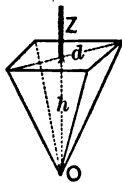

FIG. 117.

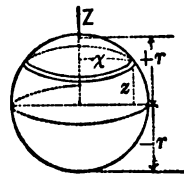

FIG. 118.

102. **Homogeneous Right Pyramid of Rectangular Base.**—*About its geometrical axis.*, Proceeding as in the last para-

graph, we derive $I_z = M \frac{1}{10} d^2$, in which d is the diagonal of the base.

103. Homogeneous Sphere.—About any diameter. Fig. 118. $I_z = ?$ Divide into laminæ perpendicular to Z . By § 97, and noting that $x^2 = r^2 - z^2$, we have finally, for the whole sphere,

$$\begin{aligned} I_z &= (\gamma \pi \div 2g) \left[\int_{-r}^{+r} (r^2 z - \frac{2}{3} r^2 z^3 + \frac{1}{5} z^5) dz \right] = \frac{2}{15} \gamma \pi r^5 \div g \\ &= (\frac{2}{15} \pi r^3 \gamma \div g) \frac{2}{5} r^2 = M \frac{2}{5} r^2; \therefore k_z^2 = \frac{2}{5} r^2. \end{aligned}$$

For a *segment*, of one or two bases, put proper limits for z in the foregoing, instead of $+r$ and $-r$.

104. Other Cases.—*Parabolic plate*, Fig. 119, homogeneous

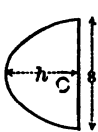

FIG. 119.

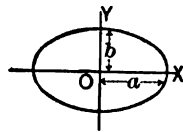

FIG. 120.

and of (any) constant thickness, about an axis through O , the middle of the chord, and perpendicular to the plate. This is

$$I = M \frac{1}{8} (\frac{1}{2} s^2 + \frac{2}{3} h^2).$$

The area of the segment is $= \frac{2}{3} h s$.

For an *elliptic plate*, Fig. 120, homogeneous and of any constant thickness, semi-axes a and b , we have about an axis through O , normal to surface $I_o = M \frac{1}{4} [a^2 + b^2]$; while for a very small constant thickness

$$I_x = M \frac{1}{4} b^2, \quad \text{and} \quad I_y = M \frac{1}{4} a^2.$$

The area of the ellipse $= \pi ab$.

Considering Figs. 119 and 120 as *plane figures*, let the student determine their polar and rectangular moments of inertia about various axes.

(For still other cases, see p. 518 of Rankine's Applied Mechanics, and pp. 593 and 594 of Coxe's Weisbach.)

105. Numerical Substitution.—The *moments of inertia of plane figures* involve dimensions of length alone, and will be utilized in the problems involving flexure and torsion of beams, where the inch is the most convenient linear unit. E.g., the

polar moment of inertia of a circle of two inches radius about its centre is $\frac{1}{2}\pi r^4 = 25.13 + \text{biquadratic}$, or *four-dimension*, inches, as it may be called. Since this quantity contains four dimensions of length, the use of the foot instead of the inch would diminish its numerical value in the ratio of the fourth power of twelve to unity.

The *moment of inertia of a rigid body, or solid*, however, $= Mk^2 = (G \div g)k^2$, in which G , the weight, is expressed in units of *force*, g involves both time and space (length), while k^2 involves length (two dimensions). Hence in any homogeneous formula in which the I of a solid occurs, we must be careful to employ units consistently; e.g., if in substituting $G \div g$ for M (as will always be done numerically) we put $g = 32.2$, we should use the *second* as unit of time, and the *foot* as linear unit.

106. Example.—Required the moment of inertia, about the axis of rotation, of a pulley consisting of a rim, four parallelepipedical arms, and a cylindrical hub which may be considered solid, being filled by a portion of the shaft.

Fig. 121. Call the weight of the hub G , its radius r ; similarly, for the rim, G_2 , r_1 and r_2 ; the weight of one arm being $= G_1$. The total I will be the sum of the I 's of the component parts, referred to the same axis, viz.: Those of the hub and rim will be $(G \div g)\frac{1}{2}r^2$ and $(G_2 \div g)\frac{1}{2}(r_1^2 + r_2^2)$, respectively (§ 97), while if the arms are

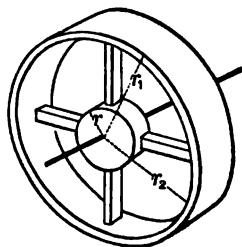

FIG. 121.

not very thick compared with their length, we have for them (§§ 95 and 88)

$$4(G_1 \div g) \left[\frac{1}{3}(r_2 - r)^2 - \frac{1}{2}(r_2 - r)^2 + \left[r + \frac{1}{3}(r_2 - r) \right]^2 \right],$$

as an approximation (obtained by reduction from the axis at the extremity of an arm to a parallel gravity-axis, then to the required axis, then multiplying by four). In most fly-wheels, the rim is proportionally so heavy, besides being the farthest removed from the axis of rotation, that the moment of inertia of the other parts may be for practical purposes neglected.

107. Ellipsoid of Inertia.—The moments of inertia about all axes passing through any given point of any rigid body whatever may be proved to be inversely proportional to the squares of the diameters which they intercept in an imaginary ellipsoid, whose centre is the given point, and whose position in the body depends on the distribution of its mass and the location of the given point. The three axes which contain the three principal diameters of the ellipsoid are called the *Principal Axes* of the body for the given point. This is called the **ellipsoid of inertia**. (Compare § 89.) Hence the moments of inertia of any homogeneous regular polyedron about all gravity-axes are equal, since then the ellipsoid becomes a sphere. It can also be proved that for any rigid body, if the co-ordinate axes X , Y , and Z , are taken coincident with the three principal axes at any point, we shall have

$$\int xy dM = 0; \quad \int yz dM = 0; \quad \text{and} \quad \int zx dM = 0.$$

CHAPTER V.

DYNAMICS OF A RIGID BODY.

108. General Method.—Among the possible motions of a rigid body the most important for practical purposes (and fortunately the most simple to treat) are: a *motion of translation*, in which the particles move in parallel right lines with equal accelerations and velocities at any given instant; and *rotation about a fixed axis*, in which the particles describe circles in parallel planes with velocities and accelerations proportional (at any given instant) to their distances from the axis. Other motions will be mentioned later. To determine relations, or equations, between the elements of the motion, the mass and form of the body, and the forces acting (which do not necessarily form an unbalanced system), the most direct method to be employed is that of two *equivalent systems* of forces (§ 15), one consisting of the actual forces acting on the body, *considered free*, the other imaginary, consisting of the infinite number of forces which, applied to the separate material points composing the body, would account for their individual motions, as if they were an assemblage of particles without mutual actions or coherence. If the body were at rest, then considered *free*, and the forces referred to three co-ordinate axes, they would constitute a balanced system, for which the six summations ΣX , ΣY , ΣZ , $\Sigma(\text{mom.})_x$, $\Sigma(\text{mom.})_y$, and $\Sigma(\text{mom.})_z$ would each = 0; but in most cases of motion some or all of these sums are equal (at any given instant), not to zero, but to the corresponding summation of the imaginary equivalent system, i.e., to expressions involving the masses of the particles (or material points), their distribution in the body, and the

elements of the motion. That is, we obtain six equations by putting the ΣX of the actual system equal to the ΣX of the imaginary, and so on; for a definite instant of time (since some of the quantities may be variable).

109. Translation.—Fig. 122. At a given instant all the particles have the same velocity $= v$, in parallel right lines (parallel to the axis X , say), and the same acceleration p . Required the ΣX of the acting forces, shown at (I.). (II.) shows the imaginary equivalent system, consisting of a force $= \text{mass} \times \text{acc.} = dMp$ applied parallel to X to each particle, since such a force would be necessary (from eq. (IV.)

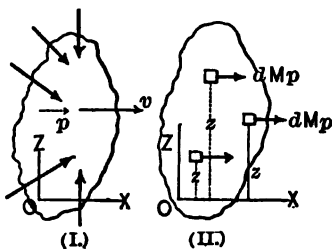

FIG. 122.

§ 55) to account for the accelerated rectilinear motion of the particle, independently of the others. Putting $(\Sigma X)_I = (\Sigma X)_{II}$ we have

$$(\Sigma X)_I = \int p dM = p \int dM = Mp. . . . (V.)$$

It is evident that the resultant of system (II.) must be parallel to X ; hence that of (I.), which $= (\Sigma X)_I$ and may be denoted by R , must also be parallel to X ; let a = perpendicular distance from R to the plane YX ; a will be parallel to Z . Now pnt $[\Sigma(\text{mom.})_Y]_I = [\Sigma(\text{mom.})_Y]_{II}$ (Y is an axis perpendicular to paper through O) and we have $-Ra = -\int dMpz = -p \int dMz = -pM\bar{z}$ (§ 88), i.e., $a = \bar{z}$. A similar result may be proved as regards \bar{y} . Hence, *if a rigid body has a motion of translation, the resultant force must act in a line through the centre of gravity (here more properly called the centre of mass), and parallel to the direction of motion.* Or, practically, in dealing with a rigid body having a motion of translation, we may consider it concentrated at its centre of mass. If the velocity of translation is uniform, $R = M \times 0 = 0$, i.e., the forces are balanced.

110. **Rotation about a Fixed Axis.**—First, as to the elements of space and time involved. Fig. 123. Let O be the axis of rotation (perpendicular to paper), OY a fixed line of reference, and OA a convenient line of the rotating body, passing through the axis and perpendicular to it, accompanying the body in its angular motion, which is the same as that of OA . Just as in linear motion we dealt with linear space (s), linear velocity (v), and linear acceleration (p), so here we distinguish at any instant;

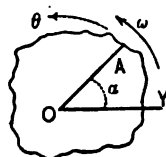

FIG. 123.

α , the *angular space* between OY and OA ;

$\omega = \frac{d\alpha}{dt}$, the *angular velocity*, or rate at which α is changing;

and

$\theta = \frac{d\omega}{dt} = \frac{d^2\alpha}{dt^2}$, the *angular acceleration*, or rate at which ω is changing.

These are all reckoned in π -measure and may be + or -, according to their direction against or with the hands of a watch.

(Let the student interpret the following cases: (1) at a certain instant ω is +, and θ -; (2) ω is -, and θ +; (3) α is -, ω and θ both +; (4) α +, ω and θ both -.) For rotary motion we have therefore, *in general*,

$$\omega = \frac{d\alpha}{dt}; \dots \dots \dots \text{(VI.)} \quad \theta = \frac{d\omega}{dt} = \frac{d^2\alpha}{dt^2}; \dots \dots \text{(VII.)}$$

$$\text{and} \quad \therefore \omega d\omega = \theta d\alpha; \dots \dots \dots \text{(VIII.)}$$

corresponding to eqs. (I.), (II.), and (III.) in § 50, for rectilinear motion.

Hence, for *uniform rotary motion*, ω being constant and $\theta = 0$, we have $\alpha = \omega t$, t being reckoned from the instant when $\alpha = 0$.

For *uniformly accelerated rotary motion* θ is constant, and

if ω_0 denote the *initial* angular velocity (when α and $t = 0$), we may derive, precisely as in § 56,

$$\omega = \omega_0 + \theta t; \quad \dots (1) \quad \alpha = \omega_0 t + \frac{1}{2}\theta t^2; \quad \dots (2)$$

$$\alpha = \frac{\omega^2 - \omega_0^2}{2\theta}; \quad \dots (3) \quad \text{and} \quad \alpha = \frac{1}{2}(\omega_0 + \omega)t. \quad \dots (4)$$

If in any problem in rotary motion θ , ω , and α have been determined for any instant, the corresponding *linear* values for any point of the body whose radial distance from the axis is ρ , will be $s = \alpha\rho$ (= distance described by the point measured along its circular path from its initial position), $v = \omega\rho$ = its velocity, and $p_t = \theta\rho$ its tangential acceleration, at the instant in question.

Examples.—(1) What value of ω , the angular velocity, is implied in the statement that a pulley is revolving at the rate of 100 revolutions per minute?

100 revolutions per minute is at the rate of $2\pi \times 100 = 628.32$ (π -measure units) of angular space per minute = 10.472 per second; $\therefore \omega = 628.32$ per minute or 10.472 per second.

(2) A grindstone whose initial speed of rotation is 90 revolutions per minute is brought to rest in 30 seconds, the angular retardation (or negative angular acceleration) being constant; required the angular acceleration, θ , and the angular space α described. Use the second as unit of time.

$$\omega_0 = 2\pi \frac{90}{60} = 9.4248 \text{ per second; } \therefore \text{from eq. (1)}$$

$$\theta = \frac{\omega - \omega_0}{t} = -9.424 \div 30 = -0.3141 \text{ (}\pi\text{-measure units)}$$

per "square second." The angular space, from eq. (2) is

$$\alpha = \omega_0 t + \frac{1}{2}\theta t^2 = 30 \times 9.42 - \frac{1}{2}(0.314)900 = 141.3$$

(π -measure units), i.e., the stone has made 22.4 revolutions in coming to rest and a point 2 ft. from the axis has described a distance $s = \alpha\rho = 141.3 \times 2 = 282.6$ ft. in its circular path.

111. Rotation. Preliminary Problem. Axis Fixed.—For clearness in subsequent matter we now consider the following

simple case. Fig. 124 shows a rigid body, consisting of a drum, an axle, a projecting arm, all of which are *imponderable*, and a *single material point*, whose weight is G and mass M . An imponderable flexible cord, in which the tension is kept constant and $= P$, unwinds from the drum. The axle coincides with the vertical axis Z , while the cord is always parallel to Y . Initially (i.e., when $t = 0$) M lies at rest in the plane ZY . Required its position at the end of any time t (i.e., at any instant) and also the reactions at the end of the bearings at O and O_1 , supposing no vertical pressure to exist at O_1 , and that P and M are at the same level. No friction. At any instant the eight unknowns, $\alpha, \omega, \theta, X_o, Y_o, Z_o, X_1,$ and Y_1 , may be found from the six equations formed by putting ΣX , etc., of the system of forces in Fig. 124, equal, respectively, to the ΣX , etc., of the imaginary equivalent system in Fig. 125, and two others to be mentioned subsequently. Since, at this instant, the velocity of M must be $v = \omega\rho$ and its tangential acceleration $p_t = \theta\rho$, its circular motion could be produced, considering it *free* (eq. (5), § 74), by a tangential force $T = \text{mass} \times p_t = M\theta\rho$, and a normal centripetal force $N = Mv^2 \div \rho = M(\omega\rho)^2 \div \rho = \omega^2 M\rho$.

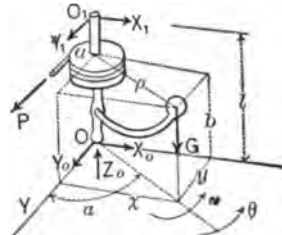

FIG. 124.

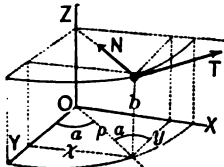

FIG. 125.

Hence the system in Fig. 125 is equivalent to that of Fig. 124, and from putting the $\Sigma (\text{mom.})_Z$ of one = that of the other, we derive

$$Pa = T\rho; \text{ i.e., } Pa = \theta M\rho^2, \dots \dots (1)$$

whence θ becomes known, and is evidently *constant*, since $P, a, M,$ and ρ are such. \therefore the angular motion is *uniformly accelerated*, and from eqs. (1) and (2), § 110, ω and α become known;

$$\text{i.e., } \omega = \theta t, \dots \dots (2) \text{ and } \alpha = \frac{1}{2}\theta t^2. \dots \dots (3)$$

Putting $(\Sigma Z \text{ of } 124) = (\Sigma Z \text{ of } 125)$, gives

$$Z_o - G = 0; \text{ i.e., } Z_o = G. \dots \dots (4)$$

Proceeding similarly with the ΣX of each system,

$$X_0 + X_1 = T \cos \alpha - N \sin \alpha = \theta M \rho \cos \alpha - \omega^2 M \rho \sin \alpha, \quad (5)$$

and with the ΣY of each,

$$P + Y_0 + Y_1 = -T \sin \alpha - N \cos \alpha = -\theta M \rho \sin \alpha - \omega^2 M \rho \cos \alpha; \quad (6)$$

while with the Σ (mom.)_x we have, conceiving all the forces in each system projected on the plane ZY (see § 38), and noting that $y = \rho \cos \alpha$ and $x = \rho \sin \alpha$,

$$+ G \rho \cos \alpha + Y_1 l + P b = -(\theta M \rho \sin \alpha) b - (\omega^2 M \rho \cos \alpha) b, \quad (7)$$

and with the Σ (mom.)_y,

$$- G \rho \sin \alpha - X_1 l = -(\theta M \rho \cos \alpha) b + (\omega^2 M \rho \sin \alpha) b. \quad (8)$$

From (7) we may find Y_1 ; from (8), X_1 ; then X_0 and Y_0 from (5) and (6). It will be noted that as the motion proceeds θ remains constant; ω increases with the time, α with the square of the time; Z_0 is constant, = G ; while X_0 , Y_0 , X_1 , and Y_1 have variable values dependent on $\rho \cos \alpha$ and $\rho \sin \alpha$, i.e., on the co-ordinates y and x of the moving material point.

112. Particular Supposition in the Preceding Problem with Numerical Substitution.—Suppose we have given (using the *foot-pound-second system* of units in which $g = 32.2$) $G = 64.4$ lbs., whence

$M = (G \div g) = 2$; $P = 4$ lbs., $l = 4$ ft., $b = 2$ ft., $a = 2$ ft., and $\rho = 4$ ft.; and that M is just passing through the plane ZX , i.e., that $\alpha = \frac{1}{4}\pi$. We obtain, first, the angular acceleration, eq. (1),

$$\theta = Pa \div M\rho^2 = 8 \div 32 = 0.25 = \frac{1}{4}.$$

From eqs. (2) and (3) we have *at the instant mentioned* (noting that when α was = 0, t was = 0)

$$\omega^2 = 2\alpha\theta = \frac{1}{4}\pi = 0.7854 +,$$

while (2) gives, for the time of describing the quadrant,

$$t = \omega \div \theta = 3.544. \dots \text{seconds.}$$

Since at this instant $\cos \alpha = 0$ and $\sin \alpha = 1$, we have, from (7),

$$+ 0 + Y_1 \times 4 + 4 \times 2 = -\frac{1}{4} \times 2 \times 4 \times 2; \therefore Y_1 = -3 \text{ lbs.}$$

The minus sign shows it should point in a direction contrary to that in which it is drawn in Fig. 124. Eq. (8) gives

$$-64.4 \times 4 - X_1 \times 4 = -0 + \frac{1}{2}\pi \times 2 \times 4 \times 2; \therefore X_1 = -67.54 \text{ lbs.}$$

And similarly, knowing Y_1 and X_1 , we have from (5) and (6),

$$X_0 = +61.26 \text{ lbs., and } Y_0 = -3.00 \text{ lbs.}$$

The resultant of X_1 and Y_1 , also that of X_0 , Y_0 , and Z_0 , can now be found by the parallelogram (and parallelipedon) of forces, both in amount and position, noting carefully the directions of the components. These resultants are the actions of the supports upon the ends of the axle; *their equals and opposites* would be the actions or pressures of the axle against the supports, at the instant considered (when M is passing through the plane ZX ; i.e., with $\alpha = \frac{1}{2}\pi$). (At the same instant, suppose *the string to break*; what would be the effect on the eight quantities mentioned?)

113. Centre of Percussion of a Rod suspended from one End.—

Fig. 126. The rod is initially at rest (see (I.) in figure), is straight, homogeneous, and of constant (small) cross-section. Neglect its weight. A horizontal force or pressure, P , due to a blow (and varying in amount during the blow), now acts upon it from the left, perpendicularly to the axis, Z , of suspension. An accelerated rotary motion begins about the fixed axis Z .

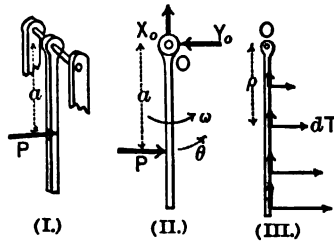

FIG. 126.

(II.) shows the rod *free*, at a certain instant, with the reactions X_0 and Y_0 put in at O . (III.) shows an imaginary system which would produce the same effect at this instant, and consisting of a $dT = dM\theta\omega$, and a $dN = \omega^2 dM\rho$ applied to each dM , the rod being composed of an infinite number of dM 's, each at some distance ρ from the axis. Considering that *the rotation has just begun*, ω , the angular velocity is as yet small, and will be neglected. Required Y_0 , the horizontal reaction of the support at O in terms of P . By putting $\sum Y_{II} = \sum Y_{III}$, we have

$$P - Y_0 = \int dT = \int \theta \rho dM = \theta M \bar{\rho}.$$

$\therefore Y_0 = P - \theta M \bar{\rho}$; $\bar{\rho}$ is the distance of the centre of gravity from the axis (N.B. $\int \rho dM = M \bar{\rho}$ is only true when all the ρ 's are parallel to each other). But the value of the angular acceleration θ at this instant depends on P and a , for Σ (mom.)_z in (II.) = Σ (mom.)_z in (III.), whence $Pa = \theta \int \rho^2 dM = \theta I_z$, where I_z is the *moment of inertia* of the rod about Z , and from § 95 = $\frac{1}{3} M l^2$. Now $\bar{\rho} = \frac{1}{3} l$; hence, finally,

$$Y_0 = P \left[1 - \frac{3}{2} \cdot \frac{a}{l} \right].$$

If now Y_0 is to be = 0, i.e., if there is to be *no shock between the rod and axis*, we need only apply P at a point whose distance $a = \frac{2}{3} l$ from the axis; for then $Y_0 = 0$. This point is called the **centre of percussion** for the given rod and axis. It and the point of suspension O are interchangeable (see § 118). (Lay a pencil on a table; tap it at a point distant one third of the length from one end; it will *begin to rotate* about a vertical axis through the farther end. Tap it at one end; it will begin to rotate about a vertical axis through the point first mentioned. Such an axis of rotation is called an *axis of instantaneous rotation*, and is different for each point of impact—just as the point of contact of a wheel and rail is the one point of the wheel which is momentarily at rest, and about which, therefore, all the others are turning *for the instant*. Tap the pencil at its centre of gravity, and a motion of translation begins; see § 109.)

114. Rotation. Axis Fixed. General Formulæ.—Consider

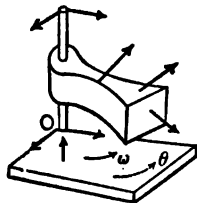

FIG. 127.

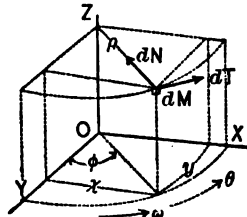

FIG. 128.

ing now a rigid body of any shape whatever, let Fig. 127 indicate the system of forces acting *at any given instant*, Z being

the fixed axis of rotation, ω and θ the angular velocity and angular acceleration, *at the given instant*. X and Y are two axes, at right angles to each other and to Z , fixed in space. At this instant each dM of the body has a definite x, y , and φ (see Fig. 128), which will change, and also a ρ , and z , which will not change, as the motion progresses, and is pursuing a circular path with a velocity $= \omega\rho$ and a tangential acceleration $= \theta\rho$. Hence, if to each dM of the body (see Fig. 128) we imagine a tangential force $dT = dM\theta\rho$ and a normal force $= dM(\omega\rho)^2 \div \rho = \omega^2 dM\rho$ to be applied (eq. (5), § 74), and these alone, we have a system comprising an infinite number of forces, all parallel to XY , and equivalent to the actual system in Fig. 127. Let ΣX , etc., represent the sums (six) for Fig. 127, whatever they may be in any particular case, while for 128 we shall write the corresponding sums in detail. Noting that

$$fdN \cos \varphi = \omega^2 fdM\rho \cos \varphi = \omega^2 fdMy = \omega^2 My\bar{y}, (\S 88);$$

that $fdN \sin \varphi = \omega^2 fdM\rho \sin \varphi = \omega^2 fdMx = \omega^2 Mx\bar{x}$;

and similarly, that $fdT \cos \varphi = \theta fdM\rho \cos \varphi = \theta My\bar{y}$, and $fdT \sin \varphi = \theta Mx\bar{x}$; while in the moment sums (the moment of $dT \cos \varphi$ about Y , for example, being $-dT \cos \varphi \cdot z = -\theta dM\rho (\cos \varphi)z = -\theta dMyz$, the sum of the moms. _{Y} of all the $(dT \cos \varphi)$'s $= -\theta fdMyz$)

$$fdT \cos \varphi z = \theta fdMyz, fdN \sin \varphi z = \omega^2 fdMxz, \text{ etc.,}$$

we have, since the systems are equivalent,

$$\Sigma X = +\theta My\bar{y} - \omega^2 Mx\bar{x}; \dots \dots \dots (IX.)$$

$$\Sigma Y = -\theta Mx\bar{x} - \omega^2 My\bar{y}; \dots \dots \dots (X.)$$

$$\Sigma Z = 0; \dots \dots \dots (XI.)$$

$$\Sigma \text{ moms.}_X = -\theta fdMxz - \omega^2 fdMyz; \dots (XII.)$$

$$\Sigma \text{ moms.}_Y = -\theta fdMyz + \omega^2 fdMxz; \dots (XIII.)$$

$$\Sigma \text{ moms.}_Z = \theta fdM\rho^2 = \theta I_Z \dots \dots (XIV.)$$

These hold good for any instant. As the motion proceeds \bar{x} and \bar{y} change, as also the sums $fdMxz$ and $fdMyz$. If the body, however, is homogeneous, and *symmetrical about the plane XY* , $fdMxz$ and $fdMyz$ would always $=$ zero; since

the z of any dM does not change, and for every term $dMy(+z)$, there would be a term $dMy(-z)$ to cancel it; similarly for $fdMxz$. The eq. (XIV.), Σ (mom. about axis of rotat.) = $fdT\rho = \theta fdM\rho^2 =$ (angular accel.) \times (mom. of inertia of body about axis of rotat.), shows how the sum $fdM\rho^2$ arises in problems of this chapter. That a force $dT = dM\theta\rho$ should be necessary to account for the acceleration (tangential) $\theta\rho$ of the mass dM , is due to the so-called *inertia* of the mass (§ 54), and its moment $dT\rho$, or $\theta dM\rho^2$, might, with some reason, be called the *moment of inertia* of the dM , and $\int \theta dM\rho^2 = \theta \int dM\rho^2$ that of the whole body. But custom has restricted the name to the sum $\int dM\rho^2$, which, being without the θ , has no term to suggest the idea of inertia. For want of a better the name is still retained, however, and is generally denoted by I . (See §§ 86, etc.)

115. Example of the Preceding.—A homogeneous right parallelepiped is mounted on a vertical axle (no friction), as in figure.

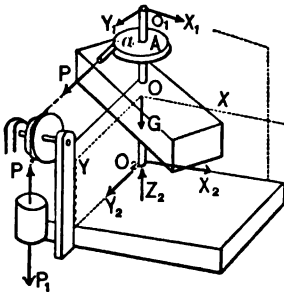

FIG. 129.

as in figure. O is at its centre of gravity, hence both \bar{x} and \bar{y} are zero. Let its heaviness be γ , its dimensions h, b_1 , and b_2 (see § 97). XY is a plane of symmetry, hence both $\int dMxz$ and $\int dMyz$ are zero at all times (see above). The tension P in the (inextensible) cord is caused by the hanging weight P_1 (but is not $= P_1$, unless the rotation is uniform). The figure shows both rigid bodies *free*. P_1 will have a motion of translation; the parallelepiped, one of rotation about a fixed axis. No masses are considered except $P_1 \div g$, and $hb_1b_2\gamma \div g$. The $I_z = Mk_z^2$ of the latter = its mass $\times \frac{1}{12}(b_1^2 + b_2^2)$, § 97. At any instant, the cord being taut, if $p =$ linear acceleration of P_1 , we have

$$p = \theta a. \quad \dots \dots \dots \text{eq. (a)}$$

From (XIV.), $Pa = \theta I_z$; $\therefore P = \theta I_z \div a. \quad \dots \dots (1)$

For the free mass $P_1 \div g$ we have (§109) $P_1 - P = \text{mass} \times \text{acc.}$,

$$= (P_1 \div g)p = (P_1 \div g)\theta a; \therefore P = P_1(1 - \theta a \div g). \quad (2)$$

Equate these two values of P and solve for θ , whence

$$\theta = \frac{P_1 a}{Mk_z^2 + (P_1 \div g)a^2} \quad \dots \quad (3)$$

All the terms here are *constant*, hence θ is constant; therefore the rotary motion is *uniformly accelerated*, as also the translation of P_1 . The formulæ of § 56, and (1), (2), (3), and (4) of § 110, are applicable. The tension P is also constant; see eq. (1). As for the five unknown reactions (components) at O_1 and O_2 , the bearings, we shall find that they too are constant; for

from (IX.) we have $X_1 + X_2 = 0; \quad (4)$

from (X.) we have $P + Y_1 + Y_2 = 0; \quad (5)$

from (XI.) we have $Z_2 - G = 0; \quad (6)$

from (XII.) we have $P \cdot \overline{AO} + Y_1 \cdot \overline{O_1O} - Y_2 \cdot \overline{O_2O} = 0; \quad (7)$

from (XIII.) we have $-X_1 \cdot \overline{O_1O} + X_2 \cdot \overline{O_2O} = 0. \quad (8)$

Numerical substitution in the above problem.—Let the parallelepiped be of wrought-iron; let $P_1 = 48$ lbs.; $a = 6$ in. = $\frac{1}{2}$ ft.; $b = 3$ in. = $\frac{1}{4}$ ft. (see Fig. 112); $b_1 = 2$ ft. 3 in. = $\frac{5}{4}$ ft.; and $h = 4$ in. = $\frac{1}{3}$ ft. Also let $\overline{O_1O} = \overline{O_2O} = 18$ in. = $\frac{3}{2}$ ft., and $\overline{AO} = 3$ in. = $\frac{1}{4}$ ft. Selecting the *foot-pound-second* system of units, in which $g = 32.2$, the linear dimensions must be used in feet, the heaviness, γ , of the iron must be used in *lbs. per cubic foot*, i.e., $\gamma = 480$ (see § 7), and all forces in lbs., times in seconds.

The weight of the iron will be $G = V\gamma = bb_1h\gamma = \frac{1}{4} \cdot \frac{5}{4} \cdot \frac{1}{3} \times 480 = 90$ lbs.; its mass = $90 \div 32.2 = 2.79$; and its moment of inertia about $Z = I_z = Mk_z^2 = M\frac{1}{12}(b_1^2 + b^2) = 2.79 \times 0.426 = 1.191$. (That is, the *radius of gyration*, $k_z = \sqrt{0.426} = 0.653$ ft.; or the moment of inertia, or any result depending solely upon it, is just the same as if the mass were concentrated in a thin shell, or a line, or a point, at a distance of 0.653 feet from the axis.) We can now compute the angular acceleration, θ , from eq. (3);

$$\theta = \frac{48 \times \frac{1}{4}}{1.191 + (48 \div 32.2) \times \frac{1}{4}} = \frac{24}{1.191 + 0.372} = 15.36$$

π -measure units per "square second." The linear acceleration of P , is $p = \theta a = 7.68$ feet per square second for the uniformly accelerated translation.

Nothing has yet been said of the velocities and initial conditions of the motions; for what we have derived so far applies to any point of time. Suppose, then, that the angular velocity $\omega = \text{zero}$ when the time, $t = 0$; and correspondingly the velocity, $v = \omega a$, of translation of P , be also = 0 when $t = 0$. At the end of any time t , $\omega = \theta t$ (§§ 56 and 110) and $v = \theta t a = \theta a t$; also the angular space, $\alpha = \frac{1}{2} \theta t^2$, described by the parallelopiped during the time t , and the linear space $s = \frac{1}{2} \theta a t^2 = \frac{1}{2} \theta a t^2$, through which the weight P , has sunk vertically. For example, during the first second the parallelopiped has rotated through an angle $\alpha = \frac{1}{2} \theta t^2 = \frac{1}{2} \times 15.36 \times 1 = 7.68$ units, π -measure, i.e., $(7.68 \div 2\pi) = 1.22$ revolutions, while P , has sunk through $s = \frac{1}{2} \theta a t^2 = 3.84$ ft., vertically.

The tension in the cord, from (2), is

$$P = 48(1 - 15.36 \times \frac{1}{4} \div g) = 48(1 - 0.24) = 36.48 \text{ lbs.}$$

The pressures at the bearings will be as follows, *at any instant*: from (4) and (8), X_1 and X_2 must individually be zero; from (6) $Z_1 = G = V\gamma = 90$ lbs.; while from (5) and (7), $Y_1 = -21.28$ lbs., and $Y_2 = -15.20$ lbs., and should point in a direction opposite to that in which they were assumed in Fig. 129 (see last lines of § 39).

116. Torsion Balance. A Variably Accel. Rotary Motion. Axis Fixed.—

A homogeneous solid having an axis of symmetry is suspended by an elastic prism, or filament (whose mass may be neglected), so that the latter is vertical and coincident with the axis of symmetry, and is not only supported, but prevented from turning at its upper extremity. If the solid is turned about its axis away from its position of rest and set free, the torsional

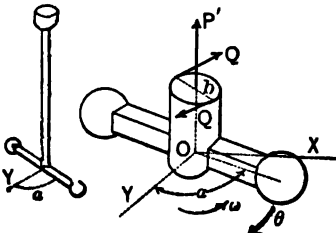

FIG. 180.

elasticity of the rod or filament, which is fixed in the solid, causes an oscillatory rotary motion. Required the duration of an oscillation. Fig. 130.

Take the axis Y at the middle of the oscillation (the original position of rest). Reckon the time from the instant of passing this position. Let the initial angular velocity $= \omega$. As the motion progresses ω diminishes, i.e., θ is negative.

To consider the body *free*, conceive the rod cut close to the body (in which it is *firmly inserted*), and in the section thus exposed put in the vertical tension P' , and also the horizontal forces forming a couple to which at any instant the twisting action (of the portion of rod removed upon the part left in the free body) is known to be due. Call the moment of this couple Qb (known as the *moment of torsion*); it is variable, being directly proportional to the angle α ; hence, if by experiment it is found to be $= Q_1 b_1$, when α is $= \alpha_1$, for any value of α it will be $Qb = (Q_1 b_1 \div \alpha_1) \alpha = C\alpha$, in which C is the constant factor.

At any instant, therefore, the forces acting are G , P' , and those equivalent to the couple whose moment $= Qb = C\alpha$. (No lateral support is required; the student would find the X_1 , Y_1 , X_2 , and Y_2 of Fig. 129 to be individually zero, if put in; remembering that here, \bar{x} and \bar{y} both $= 0$, as also $\int dMxz$ and $\int dMyz$; and that the forces of the couple will not be represented in any of the six summations of § 114, except in Σ moms._z)

From eq. (XIV.), § 114, we have $-Qb$, i.e., $-C\alpha$, $= \theta I_z$, from which

$$\theta = -(C \div I_z)\alpha, \text{ or, for short, } \theta = -B\alpha. \quad (1)$$

Since B is constant, and there is an initial (angular) velocity $= \omega$, and since the variables θ , ω , and α , in angular motion correspond precisely to those (p , v , and s) of rectilinear motion, it is evident that the present is a case of *harmonic motion*, already discussed in Problem 2 of § 59. Applying the results there obtained, since B of eq. (1) corresponds to the a of that problem, we find that the oscillations are *isochronal*, i.e., their

durations are the same whatever the amplitude (provided the elasticity of the rod is not impaired), and that the duration of one oscillation (from one extreme position to the other) is $t' = \pi \div \sqrt{B}$, or finally,

$$t' = \pi \sqrt{\alpha, I_z \div Q, b_1} \dots \dots \dots (2)$$

117. **The Compound Pendulum** is any rigid body allowed to oscillate without friction under the action of gravity when mounted on a horizontal axis. Fig. 131 shows the body *free*, in any position during the progress of the oscillation. *C* is the centre of gravity; let $\overline{OC} = s$. From (XIV.), § 114, we have Σ (mom. about fixed axis)

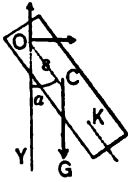

FIG. 131.

$$= \text{angul. acc.} \times \text{mom. of inertia.}$$

$$\begin{aligned} \therefore -Gs \sin \alpha &= \theta I_o, \\ \text{and } \theta &= -Gs \sin \alpha \div I_o = -Mgs \sin \alpha \div Mk_o^2, \\ \text{i.e., } \theta &= -g \sin \alpha \div k_o^2 \dots \dots \dots (1) \end{aligned}$$

Hence θ is variable, proportional to $\sin \alpha$. Let us see what the length $l = \overline{OK}$, of a simple circular pendulum, must be, to have at this instant (i.e., for this value of α) the same angular acceleration as the rigid body. The linear (tangential) accelerations of *K*, the extremity of the required simple pendulum would be (§ 77) $p_t = -g \sin \alpha$, and hence its angular acceleration would be $-g \sin \alpha \div l$. Writing this equal to θ in eq. (1), we obtain

$$l = k_o^2 \div s \dots \dots \dots (2)$$

But this is *independent of* α ; therefore the length of the simple pendulum having an angular acceleration equal to that of the oscillating body is *the same in all positions of the latter*, and if the two begin to oscillate simultaneously from a position of rest at any given angle α , with the vertical, they will keep abreast of each other during the whole motion, and hence have

the same duration of oscillation; which is \therefore , for small amplitudes (§ 78),

$$t = \pi \sqrt{l \div g} = \pi \sqrt{k_o^2 \div gs}, \dots (3)$$

K is called the *centre of oscillation* corresponding to the given *centre of suspension* O , and is identical with the *centre of percussion* (§ 113).

Example.—Required the time of oscillation of a cast-iron cylinder, whose diameter is 2 in. and length 10 in., if the axis of suspension is taken 4 in. above its centre. If we use 32.2 for g , all linear dimensions should be in feet and times in seconds. From § 100, we have

$$I_C = M(\frac{1}{4}r^2 + \frac{1}{12}h^2) = M(\frac{1}{4} \cdot \frac{1}{144} + \frac{1}{12} \cdot \frac{100}{144}) = M_{\frac{1}{144}} \cdot \frac{103}{12}$$

From eq. (3), § 88,

$$I_o = I_C + Ms^2 = M[\frac{1}{144} \cdot \frac{103}{12} + \frac{1}{9}] = M \times 0.170;$$

$\therefore k_o^2 = 0.170$ sq. ft.; $\therefore t = \pi \sqrt{0.170 \div (32.2 \times \frac{1}{3})} = 0.395$ sec.

118. The Centres of Oscillation and Suspension are Interchangeable.—(Strictly speaking, these centres are points in the line through the centre of gravity perpendicular to the axis of suspension.) Refer the centre of oscillation K to the centre of gravity, thus (Fig. 132, at (I.)):

$$s_1 = l - s = \frac{Mk_o^2}{Ms} - s = \frac{Mk_c^2 + Ms^2}{Ms} - s = \frac{k_c^2}{s}. \quad (1)$$

Now invert the body and suspend it at K ; required CK_1 , or s_2 , to find the centre of oscillation corresponding to K as centre of suspension. By analogy from (1) we have $s_2 = k_c^2 \div s_1$; but from (1), $k_c^2 \div s_1 = s \therefore s_2 = s$; in other words, K_1 is identical with O . Hence the proposition is proved.

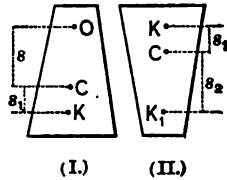

FIG. 132.

Advantage may be taken of this to determine the length L of the theoretical simple pendulum vibrating seconds, and thus finally the acceleration of gravity from formula (3), § 117, viz.,

when $t' = 1.0$ and l (now = L) has been determined experimentally, we have

$$g \text{ (in ft. per sq. second)} = L \text{ (in ft.)} \times \pi^2. \quad (2)$$

This most accurate method of determining g at any locality requires the use of a bar of metal, furnished with a sliding weight for shifting the centre of gravity, and with two projecting blocks provided with knife-edges. These blocks can also be shifted and clamped. By suspending the bar by one knife-edge on a proper support, the duration of an oscillation is computed by counting the total number in as long a period of time as possible; it is then reversed and suspended on the other with like observations. By shifting the blocks between successive experiments, the duration of the oscillation in one position is made the same as in the other, i.e., the distance between the knife-edges is the length, l , of the simple pendulum vibrating in the computed time (if the knife-edges are not equidistant from the centre of gravity), and is carefully measured. The l and t' of eq. (3), § 117, being thus known, g may be computed. Professor Bartlett gives as the length of the simple pendulum vibrating seconds at any latitude β

$$L \text{ (in feet)} = 3.26058 - 0.008318 \cos 2\beta.$$

119. Isochronal Axes of Suspension.—*In any compound pendulum, for any axis of suspension, there are always three others, parallel to it in the same gravity-plane, for which the oscillations are made in the same time as for the first.* For any assigned time of oscillation t' , eq. (3), § 117, compute the corresponding distance $\overline{CO} = s$ of O from C ;

$$\text{i.e., from} \quad t'^2 = \pi^2 \frac{Mk_o^2}{Mgs} = \frac{\pi^2(Mk_c^2 + Ms^2)}{Mgs},$$

$$\text{we have} \quad s = (gt'^2 \div 2\pi^2) \pm \sqrt{(gt'^2 \div 4\pi^2) - k_c^2}. \quad (1)$$

Hence for a given t' , there are two positions for the axis O parallel to any axis through C , in any gravity-plane, on both sides; i.e., *four parallel axes of suspension*, in any gravity-plane, giving equal times of vibration; for two of these axes

we must reverse the body. E.g., if a slender, homogeneous, prismatic rod be marked off into thirds, the (small) vibrations will be of the same duration, if the centre of suspension is taken at either extremity, or at either point of division.

Example.—Required the positions of the axes of suspension, parallel to the base, of a right cone of brass, whose altitude is six inches, radius of base, 1.20 inches, and weight per cubic inch is 0.304 lbs., so that the time of oscillation may be a half-second. (N.B. For variety, use the inch-pound-second system of units, first consulting § 51.)

120. The Fly-Wheel in Fig. 133 at any instant experiences a pressure P' against its crank-pin from the connecting-rod and a resisting pressure P'' from the teeth of a spur-wheel with

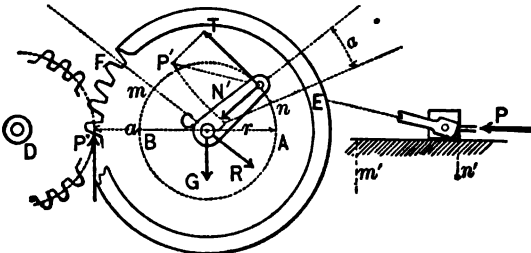

FIG 133.

which it gears. Its weight G acts through C (nearly), and there are pressures at the bearings, but these latter and G have no moments about the axis C (perpendicular to paper). The figure shows it *free*, P'' being assumed constant (in practice this depends on the resistances met by the machines which D drives, and the fluctuation of velocity of their moving parts). P' , and therefore T its tangential component, are variable, depending on the effective steam-pressure on the piston at any instant, on the obliquity of the connecting-rod, and in high-speed engines on the masses and motions of the piston and connecting-rod. Let r = radius of crank-pin circle, and a the perpendicular from C on P'' . From eq. (XIV.), § 114, we have

$$Tr - P''a = \theta I_C, \therefore \theta = (Tr - P''a) \div I_C \quad (1)$$

as the angular acceleration at any instant ; substituting which in the general equation (VIII.), § 110, we obtain

$$I_C \omega d\omega = Trd\alpha - P''ada. \dots (2)$$

From (1) it is evident that if at any position of the crank-pin the variable Tr is equal to the constant $P''a$, θ is zero, and consequently the angular velocity ω is either a maximum or a minimum. Suppose this is known to be the case both at m and n ; i.e., suppose T , which was zero at the dead-point A , has been gradually increasing, till at n , $Tr = P''a$; and thereafter increases still further, then begins to diminish, until at m Tr again $= P''a$, and continues to diminish toward the dead-point B . The angular velocity ω , whatever it may have been on passing the dead-point A , diminishes, since θ is negative, from A to n , where it is ω_n , a minimum ; increases from n to m , where it reaches a maximum value, ω_m . n and m being known points, and supposing ω_n known, let us inquire what ω_m will be. From eq. (2) we have

$$I_C \int_n^m \omega d\omega = \int_n^m Trd\alpha - P'' \int_n^m ada. \dots (3)$$

But $rda = ds =$ an element of the path of the crank-pin, and also the "virtual velocity" of the force T , and $ada = ds''$, an element of the path of a point in the pitch-circle of the fly-wheel, the small space through which P'' is overcome in dt . Hence (3) becomes

$$I_C \frac{1}{2} (\omega_m^2 - \omega_n^2) = \int_n^m Tds - P'' \times \text{linear arc } \overline{EF}. (4)$$

To determine $\int_n^m Tds$ we might, by a knowledge of the varying steam-pressure, the varying obliquity of the connecting-rod, etc., determine T for a number of points equally spaced along the curve nm , and obtain an approximate value of this sum by Simpson's Rule ; but a simpler method is possible by noting (see eq. (1), § 65) that each term Tds of this sum = the corresponding term Pdx in the series $\int_n^{m'} Pdx$, in which $P =$ the

effective steam-pressure on the piston in the cylinder at any instant, dx the small distance described by the piston while the crank-pin describes any ds , and n' and m' the positions of the piston (or of cross-head, as in Fig. 133) when the crank-pin is at n and m respectively. (4) may now be written

$$I_{c\frac{1}{2}}(\omega_m^2 - \omega_n^2) = \int_{n'}^{m'} P dx - P'' \times \text{linear arc } \overline{EF}, \quad (5)$$

from which ω_m may be found as proposed. More generally, it is available, alone (or with other equations), to determine any one (or more, according to the number of equations) unknown quantity. This problem, in rotary motion, is analogous to that in § 59 (Prob. 4) for rectilinear motion. Friction and the inertia of piston and connecting-rod have been neglected. As to the time of describing the arc nm , from equations similar to (5), we may determine values of ω for points along nm , dividing it into an even number of equal parts, calling them $\omega_1, \omega_2, \text{etc.}$, and then employ Simpson's Rule for an approximate value of the sum $\int_n^m t = \int_n^m \frac{d\alpha}{\omega}$ (from eq. (VI.), § 110); e.g., with four parts, we would have

$$\int_n^m t = \frac{1}{12} (\text{angle } nCm, \pi\text{-meas.}) \left[\frac{1}{\omega_n} + \frac{4}{\omega_1} + \frac{2}{\omega_2} + \frac{4}{\omega_3} + \frac{1}{\omega_m} \right]. \quad (6)$$

121. Numerical Example. Fly-Wheel.—(See Fig. 133 and the equations of § 120.) Suppose the engine is non-condensing and non-expansive (i.e., that P is constant), and that

$$P = 5500 \text{ lbs.}, \quad r = 6 \text{ in.} = \frac{1}{2} \text{ ft.}, \quad a = 2 \text{ ft.},$$

and also that the wheel is to make 120 revolutions per minute, i.e., that its *mean angular velocity* is to be

$$\omega' = \frac{120}{60} \times 2\pi, \text{ i.e., } \omega' = 4\pi \text{ "radians" per sec.}$$

First, required the amount of the resistance P'' (constant) that there shall be no permanent change of speed, i.e., that the angular velocity shall have the same value at the end of a complete revolution as at the beginning. Since an equation of the form of eq. (5) holds good for any range of the motion, let

that range be a complete revolution, and we shall have zero as the left-hand member; $\int P dx = P \times 2 \text{ ft.} = 5500 \text{ lbs.} \times 2 \text{ ft.}$, or 11,000 foot-pounds (as it may be called); while P'' is unknown, and instead of lin. arc \overline{EF} we have a whole circumference of 2 ft. radius, i.e., 4π ft.;

$$\therefore 0 = 11,000 - P'' \times 4 \times 3.1416; \text{ whence } P'' = 875 \text{ lbs.}$$

Secondly, required the proper mass to be given to the fly-wheel of 2 ft. radius that in the forward stroke (i.e., while the crank-pin is describing its *upper* semicircle) the max. angular velocity ω_m shall exceed the minimum ω_n by only $\frac{1}{10}\omega'$, assuming (which is nearly true) that $\frac{1}{2}(\omega_m + \omega_n) = \omega'$. There being now three unknowns, we require three equations, which are, including eq. (5) of § 120, viz.:

$$Mk_C \frac{1}{2}(\omega_m + \omega_n)(\omega_m - \omega_n) = \int_n^{m'} P dx - P'' \times \text{linear arc } \overline{EF}; \quad (5)$$

$$\frac{1}{2}(\omega_m + \omega_n) = \omega' = 4\pi; \quad (7) \quad \text{and} \quad \omega_m - \omega_n = \frac{1}{10}\omega' = \frac{2}{5}\pi. \quad (8)$$

The points n and m are found most easily and with sufficient accuracy by a graphic process. Laying off the dimensions to scale, by trial such positions of the crank-pin are found that T , the tangential component of the thrust P' produced in the connecting-rod by the steam-pressure P (which may be resolved into two components, along the connecting-rod and a normal to itself) is $= (a \div r)P''$, i.e., is = 3500 lbs. These points will be n and m (and two others on the lower semicircle). The positions of the piston n' and m' , corresponding to n and m of the crank-pin, are also found graphically in an obvious manner. We thus determine the angle nOm to be 100° , so that linear arc $\overline{EF} = \frac{1}{10}\pi \times 2 \text{ ft.} = \frac{1}{5}\pi \text{ ft.}$, while

$$\int_n^{m'} P dx = 5500 \text{ lbs.} \times \int_n^{m'} dx = 5500 \times n'm' = 5500 \times 0.77 \text{ ft.},$$

$n'm'$ being scaled from the draft.

Now substitute from (7) and (8) in (5), and we have, with $k_C = 2 \text{ ft.}$ (which assumes that the mass of the fly-wheel is concentrated in the rim),

$(G \div g) \times 4 \times 4\pi \times \frac{3}{4}\pi = 5500 \times 0.77 - 875 \times \frac{1}{2}\pi$,
 which being solved for G (with $g = 32.2$; since we have used
 the foot and second), gives $G = 600.7$ lbs.

The points of max. and min. angular velocity on the back-
 stroke may be found similarly, and their values for the fly-
 wheel as now determined; they will differ but slightly from
 the ω_m and ω_n of the forward stroke. Professor Cotterill says
 that the rim of a fly-wheel should never have a max. velocity
 > 80 ft. per sec.; and that if made in segments, not more than
 40 to 50 feet per second. In the present example we have for
 the forward stroke, from eqs. (7) and (8), $\omega_m = 13.2$ (π -measure
 units) per second; i.e., the corresponding velocity of the wheel-
 rim is $v_m = \omega_m a = 26.4$ feet per second.

122. Angular Velocity Constant. Fixed Axis.—If ω is con-
 stant, the angular acceleration, θ , must be = zero at all times,
 which requires Σ (mom.) about the axis of
 rotation to be = 0 (eq. (XIV.), § 114). An
 instance of this occurs when the only forces
 acting are the reactions at the bearings on
 the axis, and the body's weight, parallel to
 or intersecting the axis; the values of these
 reactions are now to be determined for dif-
 ferent forms of bodies, in various positions
 relatively to the axis. (The opposites and equals of these reac-
 tions, i.e., the forces with which the axis acts upon the bearings,
 are sometimes stated to be due to the "*centrifugal forces*," or
 "*centrifugal action*," of the revolving body.)

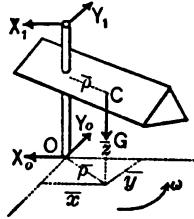

FIG. 134.

Take the axis of rotation for Z , then, with $\theta = 0$, the equa-
 tions of § 114 reduce to

$$\begin{aligned} \Sigma X &= -\omega^2 M\bar{x}; & & \text{(IXa.)} \\ \Sigma Y &= -\omega^2 M\bar{y}; & & \text{(Xa.)} \\ \Sigma Z &= 0; & & \text{(XIa.)} \\ \Sigma \text{ moms.}_X &= -\omega^2 \int dM yz; & & \text{(XIIa.)} \\ \Sigma \text{ moms.}_Y &= +\omega^2 \int dM xz; & & \text{(XIIIa.)} \\ \Sigma \text{ moms.}_Z &= 0. & & \text{(XIVa.)} \end{aligned}$$

For greater convenience, let us suppose the axes X and Y (since their position is arbitrary so long as they are perpendicular to each other and to Z) to revolve with the body in its uniform rotation.

122a. If a homogeneous body have a plane of symmetry and rotate uniformly about any axis Z perpendicular to that plane (intersecting it at O), then the acting forces are equivalent to a single force, $= \omega^2 M \bar{\rho}$, applied at O and acting in a gravity-line, but directed away from the centre of gravity.

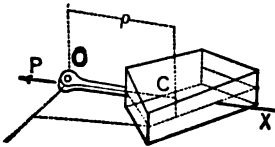

FIG. 135.

It is evident that such a force $P = \omega^2 M \bar{\rho}$, applied as stated (see Fig. 135), will satisfy all six conditions expressed in the foregoing equations, taking X through the centre of gravity, so that $\bar{x} = \bar{\rho}$. For, from (IXa.), P must $= \omega^2 M \bar{\rho}$, while in each of the other summations the left-hand member will be zero, since P lies in the axis of X ; and as their right-hand members will also be zero for the present body ($\bar{y} = 0$; and each of the sums $\int dMyz$ and $\int dMxz$ is zero, since for each term $dMy(+z)$ there is another $dMy(-z)$ to cancel it; and similarly, for $\int dMxz$), they also are satisfied; Q. E. D.*

Hence a single point of support at O will suffice to maintain the uniform motion of the body, and the pressure against it will be equal and opposite to P .

First Example.—Fig. 136. Supposing (for greater safety) that the uniform rotation of 210 revolutions per minute of each segment of a fly-wheel is maintained solely by the tension in the corresponding arm, P ; required the value of P if the segment and arm together weigh $\frac{1}{30}$ of a ton, and the distance of their centre of gravity from the axis is $\bar{\rho} = 20$ in., i.e., $= \frac{1}{3}$ ft. With the foot-ton-second system of units, with $g = 32.2$, we have

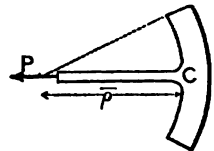

FIG. 136.

$$P = \omega^2 M \bar{\rho} = \left[\frac{210}{60} \times 2\pi \right]^2 \times \left[\frac{1}{30} \div 32.2 \right] \times \frac{1}{3} = 0.83 \text{ tons,}$$

or 1660 lbs.

* That is, neglecting gravity.

Second Example.—Fig. 137. Suppose the uniform rotation of the same fly-wheel depends solely on the tension in the rim, required its amount. The figure shows the half-rim free, with the two equal tensions, P' , put in at the surfaces exposed. Here it is assumed that the arms exert no tension on the rim. From § 122a we have $2P' = \omega^2 M \bar{\rho}$, where M is the mass of the half-rim, and $\bar{\rho}$ its gravity co-ordinate, which may be obtained approximately by § 26, Problem 1, considering the rim as a circular wire, viz., $\bar{\rho} = 2r \div \pi$.

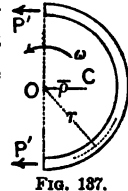

FIG. 137.

Let $M = (180 \text{ lbs.}) \div g$, with $r = 2 \text{ ft.}$ We have then

$$P' = \frac{1}{2}(22)^2(180 \div 32.2)(4 \div \pi) = 1718.0 \text{ lbs.}$$

(In reality neither the arms nor the rim sustain the tensions just computed; in treating the arms we have supposed no duty done by the rim, and *vice versa*. The actual stresses are less, and depend on the yielding of the parts. Then, too, we have supposed the wheel to take no part in the transmission of motion by belting or gearing, which would cause a bending of the arms, and have neglected its weight.)

122b. *If a homogeneous body have a line of symmetry and rotate uniformly about an axis parallel to it (O being the foot of the perpendicular from the centre of gravity on the axis), then the acting forces are equivalent to a single force $P = \omega^2 M \bar{\rho}$, applied at O and acting in a gravity-line away from the centre of gravity.*

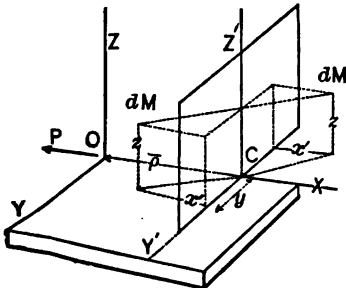

FIG. 138.

Taking the axis X through the centre of gravity, Z being the axis of rotation, Fig. 138; while Z' is the line of symmetry, pass an auxiliary plane $Z'Y'$ parallel to ZY . Then the sum $\int dM \omega^2 z$ may be written $\int dM(\bar{\rho} + x')z$ which $= \bar{\rho} \int dM z + \int dM x' z$. But $\int dM z = \bar{M} z = 0$, since $\bar{z} = 0$, and every term $dM(+x')z$ is cancelled by a numerically

$= 0$, and every term $dM(+x')z$ is cancelled by a numerically

equal term $dM(-x')z$ of opposite sign. Hence $\int dMxz = 0$. Also $\int dMyz = 0$, since each positive product is annulled by an equal negative one (from symmetry about Z'). Since, also, $\bar{y} = 0$, all six conditions in § 122 are satisfied. Q. E. D.

If the homogeneous body is any solid of revolution whose geometrical axis is parallel to the axis of rotation, the foregoing is directly applicable.

122c. If a homogeneous body revolve uniformly about any axis lying in a plane of symmetry, the acting forces are equivalent to a single force $P = \omega^2 M\bar{\rho}$, acting parallel to the gravity-line which is perpendicular to the axis (Z), and away from the centre of gravity, its distance from any origin O in the axis Z being $= [\int dMxz] \div M\bar{\rho}$ (the plane ZX being a gravity-plane).—Fig. 139.

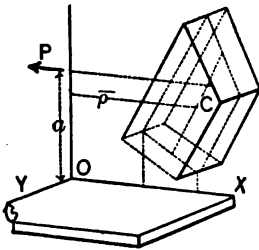

FIG. 139.

From the position of the body we have $\bar{\rho} = \bar{x}$, and $\bar{y} = 0$; hence if a value $\omega^2 M\bar{\rho}$ be given to P and it be made to act through Z and parallel to X , and away from the centre of gravity, all the conditions of § 122 are satisfied except (XIIa.) and (XIIIa.). But symmetry about the plane XZ makes $\int dMyz = 0$, and satisfies (XIIa.), and

by placing P at a distance $a = \int dMxz \div M\bar{\rho}$ from O along Z we satisfy (XIIIa.). Q. E. D.

Example.—A slender, homogeneous, prismatic rod, of length $= l$, is to have a uniform motion, about a vertical axis passing through one extremity, maintained by a cord-connection with a fixed point in this axis. Fig. 140. Given ω, φ, l , ($\bar{\rho} = \frac{1}{2}l \cos \varphi$), and F the cross-section of the rod, let s = the distance from O to any dM of the rod. dM being $= F\gamma ds \div g$. The x of any $dM = s \cos \varphi$; its $z = s \cdot \sin \varphi$;

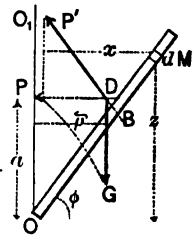

FIG. 140.

$$\begin{aligned} \therefore \int dMxz &= (F\gamma \div g) \sin \varphi \cos \varphi \int_0^l s^2 ds \\ &= \frac{1}{3}(F\gamma l + g)l^3 \sin \varphi \cos \varphi = \frac{1}{3}Ml^2 \sin \varphi \cos \varphi. \end{aligned}$$

Hence $a, = \int dMxz \div \bar{M}\bar{\rho}$, is $= \frac{1}{2}l \sin \varphi$, and the line of action of $P (= \omega^2 \bar{M}\bar{\rho} = \omega^2 (Fyl \div g) \frac{1}{2}l \cos \varphi)$ is therefore *higher up than the middle of the rod*. Find the intersection D of G and the horizontal drawn through Z at distance a from O . Determine P' by completing the parallelogram GP' , attaching the cord so as to make it coincide with P' ; for this will satisfy the condition of maintaining the motion, when once begun, viz., that the acting forces G , and the cord-tension P' , shall be equivalent to a force $P = \omega^2 \bar{M}\bar{\rho}$, applied horizontally through Z at a distance a from O .

123. Free Axes. Uniform Rotation.—Referring again to § 122 and Fig. 134, let us inquire under what circumstances the lateral forces, X_1, Y_1, X_0, Y_0 , with which the bearings press the axis, to maintain the motion, are individually zero, i.e., *that the bearings are not needed, and may therefore be removed* (except a smooth horizontal plane to sustain the body's weight), leaving the motion undisturbed like that of a top "asleep." For this, not only must ΣX and ΣY both be zero, but also (since otherwise X_1 and X_0 might form a *couple*, or Y_1 and Y_0 similarly) $\Sigma (\text{moms.})_X$ and $\Sigma (\text{moms.})_Y$ must each = zero. The necessary peculiar distribution of the body's mass about the axis of rotation, then, must be as follows (see the equations of § 122):

First, \bar{x} and \bar{y} each = 0, i.e., the axis must be a gravity-axis.

Secondly, $\int dMyz = 0$, and $\int dMxz = 0$, the origin being anywhere on Z , the axis of rotation.

An axis (Z) (of a body) fulfilling these conditions is called a **Free Axis**, and since, if either one of the three *Principal Axes* for the centre of gravity (see § 107) be made an axis of rotation (the other two being taken for X and Y), the conditions $\bar{x} = 0, \bar{y} = 0, \int dMxz = 0$, and $\int dMyz = 0$, are all satisfied, *it follows that every rigid body has at least three free axes, which are the Principal Axes of Inertia of the centre of gravity at right angles to each other.*

In the case of *homogeneous bodies* free axes can often be determined by inspection: e.g., any diameter of a sphere; any

transverse diameter of a right circular cylinder through its centre of gravity, as well as its geometrical axis; the geometrical axis of any solid of revolution; etc.

124. Rotation about an Axis which has a Motion of Translation.

—Take only the particular case where the moving axis is a gravity-axis. At any instant, let the velocity and acceleration of the axis be v and p ; the angular velocity and acceleration about that axis, ω and θ . Then, since the actual motion of a dM in any dt is compounded of its motion of rotation about the gravity-axis and the motion of translation in common with that axis, we may, in forming the imaginary equivalent system in Fig. 141, consider each dM as subjected to the simultaneous action of $dP = dM p$ parallel to X , of the tangential $dT = dM \theta \rho$, and of the normal $dN = dM (\omega \rho)^2 \div \rho = \omega^2 dM \rho$. Take X in the direction of translation, Z (perpendicular to paper through O) is the moving gravity-axis; Y perpendicular to both. At any instant we shall have, then, the following conditions for the acting forces (remembering that $\rho \sin \phi = y, \int dM y = \bar{M} y = 0$; etc.):

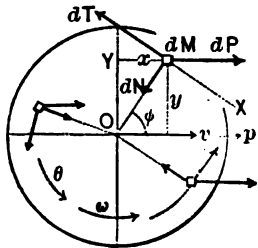

FIG. 141.

$\Sigma X = \int dP - \int dT \sin \phi - \int dN \cos \phi = M p; \dots (1)$
 $\Sigma Y = \int dT \cos \phi - \int dN \sin \phi = 0; \dots (2)$
 $\Sigma \text{ moms.}_Z = \int dT \rho - \int dP y = \theta \int dM \rho^2 = \theta I_Z = \theta M k_Z^2, (3)$

and three other equations not needed in the following example.
Example.—A homogeneous solid of revolution rolls (without slipping) down a rough inclined plane. Investigate the motion. Considering the body free, the acting forces are G (known) and N and P , the unknown normal and tangential components of the action of the plane on the roller. If slipping occurs, then P is the sliding friction due to the pressure N (§ 156); here, however, it is

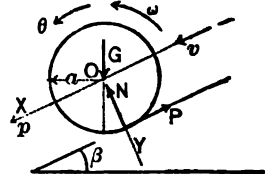

FIG. 142.

less by hypothesis (perfect rolling). At any instant the four unknowns are found by the equations

$$\Sigma X, \text{ i.e., } G \sin \beta - P, = (G \div g)p; \quad . \quad (1)$$

$$\Sigma Y, \text{ i.e., } G \cos \beta - N, = 0; \quad . \quad . \quad . \quad (2)$$

$$\Sigma \text{ moms.}_z, \text{ i.e., } Pa, = \theta M k_z^2; \quad . \quad . \quad (3)$$

while on account of the perfect rolling,

$$\theta a = p. \quad . \quad . \quad . \quad . \quad . \quad (4)$$

Solving, we have, for the acceleration of translation,

$$p = g \sin \beta \div [1 + (k_z^2 \div a^2)].$$

(If the body slid without friction, p would = $g \sin \beta$.) Hence for a cylinder (§ 97), k_z^2 being = $\frac{1}{2}a^2$, we have $p = \frac{2}{3}g \sin \beta$; and for a sphere (§ 103) $p = \frac{7}{10}g \sin \beta$.

(If the plane is so steep or so smooth that both rolling and slipping occur, then θa no longer = p , but the ratio of P to N is known from experiments on sliding friction; hence there are still four equations.)

The motion of translation being thus found to be uniformly accelerated, we may use the equations of § 56 for finding distance, time, etc.

Query.—How may we distinguish two spheres by allowing them to roll down the same inclined plane, if one of them is silver and solid, while the other is of gold, but silvered and hollow. so as to be the same as the first in diameter, weight, and appearance?

125. Parallel-Rod of a Locomotive.—When the locomotive moves uniformly, each dM of the rod between the two (or three) driving-wheels rotates with uniform velocity about a centre of its own on the line BD , Fig. 143, and with a velocity v and radius r common to all, and likewise has a horizontal *uniform* motion of translation. Hence if we inquire what are the reactions P of its supports, as induced *solely by its weight and motion*, when in its lowest position (independently of any thrust along

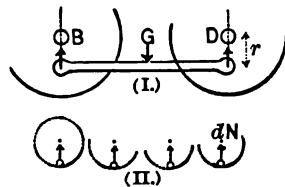

FIG. 143.

the rod), we put ΣY of (I.) = ΣY of (II.) (II. shows the imaginary equivalent system), and obtain

$$2P - G = \int dN = \int dMv^2 \div r = (v^2 \div r) \int dM = Mv^2 \div r.$$

Example.—Let the velocity of translation = 50 miles per hour, the radius of the pins be 18 in. = $\frac{3}{4}$ ft., and = *half that of the driving-wheels*, while the weight of the rod is 200 lbs. With $g = 32.2$, we must use the foot and second, and obtain

$$v = \frac{1}{2}[50 \times 5280 \div 3600] \text{ ft. per second} = 36.6;$$

$$\text{while } M = 200 \div 32.2 = 200 \times .0310 = 6.20;$$

$$\text{and finally } P = \frac{1}{2}[200 + 6.2(36.6)^2 \div \frac{3}{4}] = 2868.3 \text{ lbs.},$$

or nearly $1\frac{1}{2}$ tons, *about thirty times that due to the weight alone.*

126. So far in this chapter the motion has been prescribed, and the necessary conditions determined, to be fulfilled by the acting forces at any instant. Problems of a converse nature, i.e., where the initial state of the body and the acting forces are given while the resulting motion is required, are of much greater complexity, but of rare occurrence in practice. The reader is referred to Rankine's *Applied Mechanics*. A treatment of the Gyroscope will be found in the *American Journal of Science* for 1857, and in the article of that name in Johnson's *Cyclopædia*.

CHAPTER VI.

WORK, ENERGY, AND POWER.

127. **Remark.**—These quantities as defined and developed in this chapter, though compounded of the fundamental ideas of matter, force, space, and time, enter into theorems of such wide application and practical use as to more than justify their consideration as separate kinds of quantity.

128. **Work in a Uniform Translation. Definition of Work.**—Let Fig. 144 represent a rigid body having a motion of translation parallel to X , acted on by a system of forces $P_1, P_2, R_3,$ and $R_4,$ which remain constant.

Let s be any distance described by the body during its motion; then $\sum X$ must be zero (§ 109), i.e., noting that R_3 and R_4 have negative X components (the supplements of their angles with X are used),

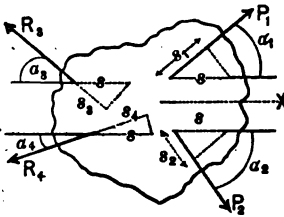

FIG. 144.

$$P_1 \cos \alpha_1 + P_2 \cos \alpha_2 - R_3 \cos \alpha_3 - R_4 \cos \alpha_4 = 0;$$

or, multiplying by s and transposing, we have (noting that $s \cos \alpha_1 = s_1$, the projection of s on P_1 , that $s \cos \alpha_2 = s_2$, the projection of s on P_2 , and so on),

$$P_1 s_1 + P_2 s_2 = R_3 s_3 + R_4 s_4. \quad \dots \dots (a)$$

The projections $s_1, s_2,$ etc., may be called the *distances described in their respective directions* by the forces $P_1, P_2,$ etc.; P_1 and P_2 having moved *forward*, since s_1 and s_2 fall *in front* of the initial position of their points of application; R_3 and R_4 *backward*, since s_3 and s_4 fall *behind* the initial positions in their case. (By forward and backward we refer to the direc-

tion of each force in turn.) The name **Work** is given to the *product of a force by the distance described in the direction of the force by the point of application*. If the force moves *forward* (see above), it is called a *working-force*, and is said to *do* the work (e.g., P, s_1) expressed by this product; while if *backward*, it is called a *resistance*, and is then said to *have the work* (e.g., R, s_2), *done upon it*, in *overcoming it* through the distance mentioned (it might also be said to have done negative work).

Eq. (a) above, then, proves the theorem that : *In a uniform translation, the working forces do an amount of work which is entirely applied to overcoming the resistances.*

129. Unit of Work.—Since the work of a force is a product of force by distance, it may logically be expressed as so many foot-pounds, inch-pounds, kilogram-meters, according to the system of units employed. The ordinary English unit is the foot-pound, or ft.-lb. It is of the same quality as a force-moment.

130. Power.—Work as already defined does not depend on the time occupied, i.e., the work P, s_1 is the same whether performed in a long or short time; but the element of time is of so great importance in all the applications of dynamics, as well as in such practical commercial matters as water-supply, consumption of fuel, fatigue of animals, etc., that the *rate of work* is a consideration both of interest and necessity.

Power is the rate at which work is done, and one of its units is one foot-pound per second in English practice; a larger one will be mentioned presently.

The *power exerted by a working force*, or *expended upon a resistance*, may be expressed symbolically as

$$L = P, s_1 \div t, \quad \text{or} \quad R, s_2 \div t,$$

in which t is the time occupied in doing the work P, s_1 , or R, s_2 , (see Fig. 144); or if v , is the component in the direction of the force P , of the velocity v of the body, we may also write

$$L = P, v. \quad (b)$$

131. *Example.*—Fig. 145, shows as a *free body*, a sledge which is being drawn *uniformly* up a rough inclined plane by a cord parallel to the plane. Required the total power exerted (and expended), if the tension in the cord is $P_1 = 100$ lbs., the weight of sledge $R_s = 160$

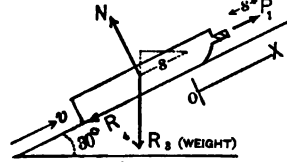

FIG. 145.

lbs., $\beta = 30^\circ$, and the sledge moves 240 ft. each minute. N and R_s are the normal and parallel (i.e., $R_s =$ friction) components of the reaction of the plane on the sledge. From eq. (1), § 128, the work done while the sledge advances through $s = 240$ ft. may be obtained either from the working forces, which in this case are represented by P_1 alone, or from the resistances R_s and R_s . Take the former method first. Projecting s upon P_1 we have $s_1 = s$.

Hence $P_1 s_1$, or $100 \text{ lbs.} \times 240 \text{ ft.} = 24,000 \text{ ft.-lbs.}$

of work done in 60 seconds. That is, the *power exerted by the working forces* is

$$L = P_1 s_1 \div t = 400 \text{ ft.-lbs. per second.}$$

As to the other method, we notice that R_s and R_s are resistances, since the projections $s_s = s \sin \beta$, and $s_1 = s$, would fall back of their points of application in the initial position, while N is *neutral*, i.e., is neither a working force nor a resistance, since the projection of s upon it is zero.

From $\sum X = 0$ we have $-R_s - R_s \sin \beta + P_1 = 0$,
and from $\sum Y = 0$ (§ 109) $N - R_s \cos \beta = 0$;

whence R_s , the friction = 20 lbs., and $N = 138.5$ lbs. Also, since $s_s = s \sin \beta = 240 \times \frac{1}{2} = 120$ ft., and $s_1 = s = 240$ ft., we have for the work done upon the resistances (i.e., in overcoming them) in 60 seconds

$$R_s s_s + R_s s_1 = 160 \times 120 + 20 \times 240 = 24,000 \text{ ft.-lbs.,}$$

and the *power expended in overcoming resistances*,

$$L = 24,000 \div 60 = 400 \text{ ft.-lbs. per second,}$$

as already derived. Or, in words the power exerted by the

tension in the cord is expended entirely in raising the weight a vertical height of 2 feet, and overcoming the friction through a distance of 4 feet along the plane, every second; *the motion being a uniform translation.*

132. Horse-Power.—As an average, a horse can exert a tractive effort or pull of 100 lbs., at a uniform pace of 4 ft. per second, for ten hours a day without too great fatigue. This gives a power of 400 ft.-lbs. per second; but Boulton & Watt in rating their engines, and experimenting with the strong dray-horses of London, fixed upon 550 ft.-lbs. per second, or 33,000 ft.-lbs. per minute, as a convenient large unit of power. (The French horse-power, or *cheval-vapeur*, is slightly less than the English, being 75 kilogrammeters per second, or 32,550 ft.-lbs. per minute.) This value for the horse-power is in common use. In the example in § 131, then, the power of 400 ft.-lbs. per second exerted in raising the weight and overcoming friction may be expressed as $(400 \div 550 =) \frac{8}{11}$ of a horse-power. A man can work at a rate equal to about $\frac{1}{12}$ of a horse-power, with proper intervals for eating and sleeping.

133. Kinetic Energy. Retarded Translation.—In a retarded translation of a rigid body whose mass = M , suppose there are no working-forces, and that the resistances are constant and their resultant is R . (E.g., Fig. 146 shows such a case; a sledge, having an initial velocity c and sliding on a rough horizontal plane, is gradually retarded by the friction R .) R is parallel to the direction of translation (§ 109) and the acceleration is $p = -R \div M$;

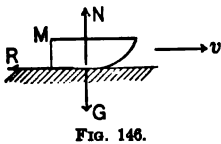

FIG. 146.

hence from $vdv = pd s$ we have

$$\int vdv = -(1 \div M) \int Rds. \quad (1)$$

But the projection of each ds of the motion upon R is = ds itself; i.e. (§ 128), Rds is the *work done upon R*, in overcoming it through the small distance ds , and $\int Rds$ is the sum of all such amounts of work throughout any definite portion of the motion. Let the range of motion be between the points

where the velocity = c , and where it = zero (i.e., the mass has come to rest). With these limits in eq. (1) (0 and s' being the corresponding limits for s), we have

$$\frac{Mc^2}{2} = \int_0^{s'} R ds. \dots \dots \dots (c)$$

That is, in giving up all its velocity c the body has been able to do the work $\int R ds$ (this, if R remains constant, reduces to Rs') or its equal $\frac{Mc^2}{2}$. If, then, by **energy** we designate the ability to perform work, we give the name **kinetic energy** of a moving body to the product of its mass by half the square of its velocity ($\frac{Mv^2}{2}$); i.e., energy due to motion. (The antiquated term *vis viva* was once applied to the form Mv^2 .)

134. Work and Kinetic Energy in any Translation.—Let P be the resultant of the working forces at any instant, R that of the resistances; they (§ 109) will both act in a gravity-line parallel to the direction of translation. The acceleration at any instant is $p = (\Sigma X \div M)$ = $(P - R) \div M$; hence from $vdv = pds$ we have

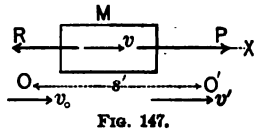

$$Mvdv = Pds - Rds. \dots \dots \dots (1)$$

Integrating between any two points of the motion as O and O' where the velocities are v_0 and v' , we have after transposition

$$\int_0^{s'} Pds = \int_0^{s'} Rds + \left[\frac{Mv'^2}{2} - \frac{Mv_0^2}{2} \right]. \dots (d)$$

But P being the resultant of P_1, P_2 , etc., and R that of R_1, R_2 , etc., we may prove, as in § 62, that if du_1, du_2 , etc., be the respective projections of any ds upon P_1, P_2 , etc., while dw_1, dw_2 , etc., are those upon R_1, R_2 , etc., then

$Pds = P_1 du_1 + P_2 du_2 + \dots$ and $Rds = R_1 dw_1 + R_2 dw_2 + \dots$; and (d) may be rewritten

$$\int_0^{v'} P_1 du_1 + \int_0^{v'} P_2 du_2 + \dots$$

$$= \int_0^{v'} R_1 dw_1 + \int_0^{v'} R_2 dw_2 + \dots + \left[\frac{Mv'^2}{2} - \frac{Mv_0^2}{2} \right]; \quad (e)$$

or, in words: *In any translation, a portion of the work done by the working forces is applied in overcoming the resistances while the remainder equals the change in the kinetic energy of the body.*

It will be noted that the bracket in (e) depends only on the initial and final velocities, and not upon any intermediate values; hence, if the initial state is one of rest, and also the final, the total change in kinetic energy is zero, and the work of the working forces has been entirely expended in the work of overcoming the resistances; but at intermediate stages the former exceeds the work so far needed to overcome resistances, and this excess is said to be *stored* in the moving mass; and as the velocity gradually becomes zero, this stored energy becomes available for aiding the working forces (which of themselves are then insufficient) in overcoming the resistances, and is then said to be *restored*. (The function of a fly-wheel might be stated in similar terms, but as that involves rotary motion it will be deferred.)

Work applied in increasing the kinetic energy of a body is sometimes called "work of inertia," as also the work done by a moving body in overcoming resistances, and thereby losing speed.

135. Example of Steam-Hammer.—Let us apply eq. (e) to determine the velocity v' attained by a steam-hammer at the lower end of its stroke (the initial velocity being = 0), just before delivering its blow upon a forging, supposing that the steam-pressure P , at all stages of the downward stroke is given by an *indicator*. Fig. 148. Weight of moving mass is 322 lbs.; $\therefore M = 10$ (foot-pound-second system), $l = 1$ foot. The *working forces* at any instant are $P_1 = G = 322$ lbs.; P_2 , which is variable, but whose values at the seven *equally spaced*

points *a, b, c, d, e, f, g*, are 800, 900, 900, 800, 600, 500, 450 lbs., respectively. R_1 , the exhaust-pressure (16 lbs. per sq. inch \times 20 sq. inches piston-area) = 320 lbs., is the only resistance, and is constant. Hence from eq. (e), since here the projections du , etc., of any ds upon the respective forces are equal to each other and = ds ,

$$P_1 \int_0^1 ds + \int_0^1 P_2 ds = R_1 \int_0^1 ds + \frac{Mv^2}{2}. \quad (1)$$

The term $\int P_2 ds$ can be obtained approximately by Simpson's Rule, using the above values for six equal divisions, which gives

$$\frac{1}{18} [800 + 4(900 + 800 + 500) + 2(900 + 600) + 450]$$

= 725 ft.-lbs. of work. Hence, making all the substitutions,

we have, since $\int_0^1 ds = 1$ ft.,

$$322 \times 1 + 725 = 320 \times 1 + \frac{1}{2} Mv^2; \therefore \frac{1}{2} Mv^2 = 727 \text{ ft.-lbs.}$$

of energy to be expended in the forging. (Energy is evidently expressed in the same kind of unit as work.) We may then say that the forging receives a blow of 727 ft.-lbs. energy. The pressure actually felt at the surface of the hammer varies from instant to instant during the compression of the forging and the gradual stopping of the hammer, and depends on the readiness with which the hot metal yields.

If the *mean resistance* encountered is R_m , and the depth of compression s'' , we would have (neglecting the force of gravity, and noting that now the initial velocity is v' , and the final zero), from eq. (c),

$$\frac{1}{2} Mv'^2 = R_m s''; \text{ i.e., } R_m = [727 \div s'' \text{ (ft.)}] \text{ lbs.}$$

E.g., if $s'' = \frac{1}{8}$ of an inch = $\frac{1}{96}$ of a foot, $R_m = 43620$ lbs., and the maximum value of R would probably be about double this near the end of the impact. If the anvil also sinks during the impact a distance s''' , we must substitute $s''' + s''$ instead of s'' ; this will give a smaller value for R_m .

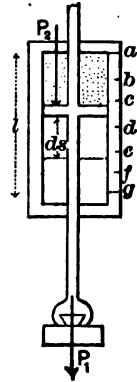

FIG. 148.

By mean value for R is meant [eq. (c)] that value, R_m , which satisfies the relation

$$R_m s' = \int_0^{s'} R ds.$$

This may be called more explicitly a *space-average*, to distinguish it from a *time-average*, which might appear in some problems, viz., a value R_{tm} , to satisfy the relation (t' being the duration of the impact)

$$R_{tm} t' = \int_0^{t'} R dt,$$

and is different from R_m .

From $\frac{1}{2} M v'^2 = 727$ ft.-lbs., we have $v' = 12.06$ ft. per sec., whereas for a free fall it would have been $\sqrt{2 \times 32.2 \times 1} = 8.03$. (This example is virtually of the same kind as Prob. 4, § 59, differing chiefly in phraseology.)

136. Pile-Driving.—The safe load to be placed upon a pile after the driving is finished is generally taken as a fraction (from $\frac{1}{4}$ to $\frac{1}{3}$) of the resistance of the earth to the passage of the pile as indicated by the effect of the last few blows of the ram, in accordance with the following approximate theory: Toward the end of the driving the resistance R encountered by the pile is nearly constant, and is assumed to be that met by the ram at the head of the pile; the distance s' through which the head of the pile sinks as an effect of the last blow is observed. If G , then, is the weight of the ram, $= Mg$, and h the height of free fall, the velocity due to h , on striking the pile, is $c = \sqrt{2gh}$ (§ 52), and we have, from eq. (c),

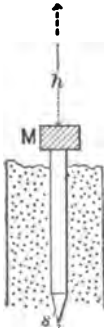

FIG. 149.

$$\frac{1}{2} M c^2, \text{ i.e., } Gh, = \int_0^{s'} R ds = R s' \quad \dots (1)$$

(R being considered constant); hence $R = Gh \div s'$, and the *safe load* (for ordinary wooden piles),

$$P = \text{from } \frac{1}{4} \text{ to } \frac{1}{3} \text{ of } Gh \div s'. \quad \dots (2)$$

Maj. Sanders recommends $\frac{1}{3}$ from experiments made at Fort

Delaware in 1851; Molesworth, $\frac{1}{8}$; General Barnard, $\frac{1}{8}$, from extensive experiments made in Holland.

Of course from eq. (2), given P , we can compute s' .

(Owing to the uncertainty as to how much of the resistance R is due to friction of the soil on the sides of the pile, and how much to the inertia of the soil around the shoe, the more elaborate theories of Weisbach and Rankine seem of little practical account.)

137. Example.—In preparing the foundation of a bridge-pier it is found that each pile (placing them 4 ft. apart) must bear safely a load of 72 tons. If the ram weighs one ton, and falls 12 ft., what should be the effect of the last blow on each pile? Using the foot-ton-second system of units, and Molesworth factor $\frac{1}{8}$, eq. (2) gives

$$s' = \frac{1}{8}(1 \times 12 \div 72) = \frac{1}{8} \text{ of a foot} = \frac{1}{4} \text{ of an inch.}$$

That is, the pile should be driven until it sinks only $\frac{1}{4}$ inch under each of the last few blows.

138. Kinetic Energy Lost in Inelastic Direct Central Impact.—Referring to § 60, and using the same notation as there given, we find that if the united kinetic energy possessed by two inelastic bodies after their impact, viz., $\frac{1}{2}M_1C^2 + \frac{1}{2}M_2C^2$, C having the value $(M_1c_1 + M_2c_2) \div (M_1 + M_2)$, be deducted from the amount before impact, viz., $\frac{1}{2}M_1c_1^2 + \frac{1}{2}M_2c_2^2$, the *loss of kinetic energy during impact of two inelastic bodies* is

$$W = \frac{\frac{1}{2}M_1M_2}{M_1 + M_2}(c_1 - c_2)^2 \dots \dots \dots (1)$$

An equal amount of energy is also lost by partially elastic bodies during the first period of the impact, but is partly regained in the second. If the bodies were perfectly elastic, we would find it wholly regained and the resultant loss zero, from the equations of § 60; but this is not quite the reality, on account of internal vibrations.

The *kinetic energy still remaining in two inelastic bodies after impact* (they move together as one mass) is

$\frac{1}{2}(M_1 + M_2)C^2$, or, after inserting the value of $C = (M_1c_1 + M_2c_2) \div (M_1 + M_2)$, we have

$$W = \frac{1}{2} \cdot \frac{[M_1c_1 + M_2c_2]^2}{M_1 + M_2} \dots \dots \dots (2)$$

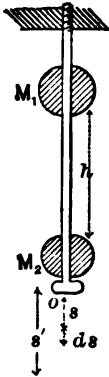

FIG. 150.

Example 1.—The weight $G_1 = M_1g$ falls freely through a height h , impinging upon a weight $G_2 = M_2g$, which was initially at rest. After their (*inelastic*) impact they move on together with the combined kinetic energy just given in (2), which, since c_1 and c_2 , the velocities before impact, are respectively $\sqrt{2gh}$ and 0, may be reduced to a simpler form. This energy is soon absorbed in overcoming the flange-pressure R , which is proportional (so long as the elasticity of the rod is not impaired) to the elongation s , as with an ordinary spring. If from previous experiment it is known that a force R_0 produces an elongation s_0 , then the variable $R = (R_0 \div s_0)s$. Neglecting the weight of the two bodies as a working force, we now have, from eq. (2),

$$0 = \frac{R_0}{s_0} \int_0^{s'} s ds + 0 - \frac{M_1^2 gh}{M_1 + M_2};$$

i.e., $\frac{R_0}{s_0} \cdot \frac{s'^2}{2} = \frac{M_1^2 gh}{M_1 + M_2} \dots \dots \dots (3)$

When $s = s'$, i.e., when the masses are (momentarily) at rest in the lowest position, the flange-pressure or tensile stress in the rod is a maximum, $R' = (R_0 \div s_0)s'$, whence $s' = R's_0 \div R_0$; and (3) may be written

$$\frac{R'}{2} s' = \frac{M_1^2 gh}{M_1 + M_2} \dots \dots \dots (4)$$

or $\frac{R'^2 s_0}{2R_0} = \frac{M_1^2 gh}{M_1 + M_2} \dots \dots \dots (5)$

Eq. (3) gives the final elongation of the rod, and (5) the greatest tensile force upon it, provided the elasticity of the rod is not

impaired. The form $\frac{1}{2}R's'$ in (4) may be looked upon as a direct integration of $\int_0^{s'} Rds$, viz., the mean resistance ($\frac{1}{2}R'$) multiplied by the whole distance (s') gives the work done in overcoming the variable R through the successive ds 's.

If the elongation is considerable, the working-forces G_1 and G_2 cannot be neglected, and would appear in the term $+(G_1 + G_2)s'$ in the right-hand members of (3), (4), and (5). The upper end of the rod is firmly fixed, and the rod itself is of small mass compared with M_1 and M_2 .

Example 2.—Two cars, Fig. 151, are connected by an elastic chain on a horizontal track. Velocities before impact (i.e., before the stretching of the chain begins, by means of which they are brought to a common velocity at the instant of greatest tension R' , and elongation s' of the chain) are $c_1 = c_1$, and $c_2 = 0$.

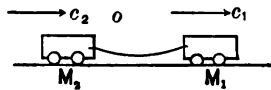

FIG. 151.

During the stretching, i.e., the first period of the impact, the kinetic energy lost by the masses has been expended in stretching the chain, i.e., in doing the work $\frac{1}{2}R's'$; hence we may write (the elasticity of the chain not being impaired) (see eq. (1))

$$\frac{1}{2} \frac{M_1 M_2 c_1^2}{M_1 + M_2} = \frac{1}{2} R' s' = \frac{R_0}{s_0} \cdot \frac{s'^2}{2} = \frac{R'^2 s_0}{2 R_0}, \quad \dots (6)$$

in which the different symbols have the same meaning as in Example 1, in which the rod corresponds to the chain of this example.

In this case the mutual accommodation of velocities is due to the presence of the chain, whose *stretching* corresponds to the *compression* (of the parts in contact) in an ordinary impact.

In numerical substitution, 32.2 for g requires the use of the units foot and second for space and time, while the unit of force may be anything convenient.

139. Work and Energy in Rotary Motion. Axis Fixed.—

The rigid body being considered free, let an axis through O perpendicular to the paper be the axis of rotation, and resolve all forces not intersecting the axis into components parallel

and perpendicular to the axis, and the latter again into components tangent and normal to the circular path of the point of application. These tangential components are evidently the only ones of the three sets mentioned which have moments about the axis, those having moments of the same sign as ω (the angular velocity at any instant) being called *working forces*, T_1, T_2 , etc.; those of opposite sign, *resistances*, T'_1, T'_2 , etc.; for when in time dt the point of application B_1 , of T_1 , describes the small arc $ds_1 = a_1 d\alpha$, whose projection on T_1 is $= ds_1$, this projection falls *ahead* (i.e., in direction of force) of the position of the point at the beginning of dt , while the reverse is true for T'_1 .

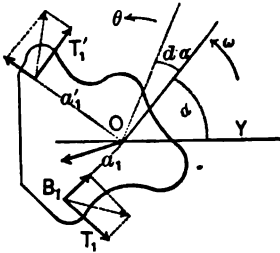

FIG. 132.

From eq. (XIV.), § 114, we have for θ (angul. accel.)

$$\theta = \frac{(T_1 a_1 + T_2 a_2 + \dots) - (T'_1 a'_1 + T'_2 a'_2 + \dots)}{I}, \quad (1)$$

which substituted in $\omega d\omega = \theta d\alpha$ (from § 110) gives (remembering that $a_1 d\alpha = ds_1$, etc.), after integration and transposition,

$$\int_0^n T_1 ds_1 + \int_0^n T_2 ds_2 + \text{etc.} = \int_0^n T'_1 ds'_1 + \int_0^n T'_2 ds'_2 + \text{etc.} + \left[\frac{1}{2} \omega_n^2 I - \frac{1}{2} \omega_0^2 I \right], \quad (2)$$

where 0 and n refer to any two (initial and final) positions of the rotating body. Eq. (4), § 120, is an example of this.

Now $\frac{1}{2} \omega_n^2 I = \frac{1}{2} \omega_n^2 dM \rho^2 = \int \frac{1}{2} dM (\omega_n \rho)^2$, which, since $\omega_n \rho$ is the actual velocity of any dM at this (final) instant, is nothing more than the sum of the amounts of kinetic energy possessed at this instant by all the particles of the body; a similar statement may be made for $\frac{1}{2} \omega_0^2 I$.

Eq. (2) therefore may be put into words as follows:

Between any two positions of a rigid body rotating about a fixed axis, the work done by the working forces is partly used in overcoming the resistances, and the remainder in changing the kinetic energy of the individual particles. If in any case

this remainder is negative, the final kinetic energy is less than the initial, i.e., the work done by the working forces is less than that necessary to overcome the resistances through their respective spaces, and the deficiency is made up by the *restoring* of some of the initial kinetic energy of the rotating body. A moving fly-wheel, then, is a reservoir of kinetic energy.

Eq. (2) has already been illustrated numerically in § 121, where the additional relation was utilized (for a connecting-rod and piston of small mass), that the work done in the steam-cylinder is the same as that done directly at the crank-pin by the working-force there.

140. Work of Equivalent Systems the Same.—*If two plane systems of forces acting on a rigid body are equivalent (§ 15a), the aggregate work done by either of them during a given slight displacement or motion of the body parallel to their plane is the same.* By aggregate work is meant what has already been defined as the sum of the “virtual moments” (§§ 61 to 64), in any small displacement of the body, viz., the algebraic sum of the products, $\Sigma(Pdu)$, obtained by multiplying each force by the projection (du) of the displacement of (or small space described by) its point of application upon the force. (We here class resistances as negative working forces.)

Call the systems A and B ; then, if all the forces of B were *reversed in direction* and applied to the body along with those of A , the compound system would be a *balanced system*, and hence we would have (§ 64), for a small motion parallel to the plane of the forces,

$$\Sigma(Pdu) = 0, \text{ i.e., } \Sigma(Pdu) \text{ for } A - \Sigma(Pdu) \text{ for } B = 0,$$

or
$$+ \Sigma(Pdu) \text{ for } A = + \Sigma(Pdu) \text{ for } B.$$

But $+ \Sigma(Pdu)$ for A is the aggregate work done by the forces of A during the given motion, and $+ \Sigma(Pdu)$ for B is a similar quantity for the forces of B (not reversed) during the same small motion if B acted alone. Hence the theorem is proved, and could easily be extended to space of three dimensions.

141. Relation of Work and Kinetic Energy for any Extended Motion of a Rigid Body Parallel to a Plane.—(If at any instant

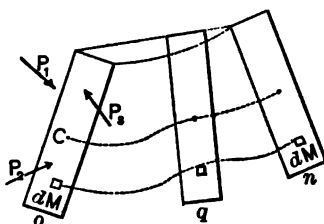

FIG. 153.

any of the forces acting are not parallel to the plane mentioned, their components lying in or parallel to that plane, will be used instead, since the other components obviously would be neither working forces nor resistances.)

Fig. 153 shows an initial position, *o*, of the body; a final, *n*; and any intermediate, as *q*. The forces of the system acting may vary in any manner during the motion.

In this motion each *dM* describes a curve of its own with varying velocity *v*, tangential acceleration *p_t*, and radius of curvature *r*; hence in any position *q*, an imaginary system *B* (see Fig. 154), equivalent to the actual system *A* (at *q* in Fig. 153), would be formed by applying to each *dM* a tangential force $dT = dMp_t$, and a normal force $dN = dMv^2 \div r$. By an infinite number of consecutive small displacements, the body passes from *o* to *n*. In the small displacement of which *q* is the initial position, each *dM* describes a space *ds*, and *dT* does the work $dTds = dMvdv$, while *dN* does the work- $dN \times 0 = 0$. Hence the total work done by *B* in the small displacement at *q* would be

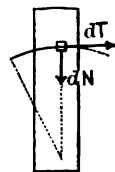

FIG. 154.

$$= dM'v'dv' + dM''v''dv'' + \text{etc.,} \dots (1)$$

including all the *dM*'s of the body and their respective velocities at this instant.

But the work at *q* in Fig. 153 by the actual forces (i.e., of system *A*) during the same small displacement must (by § 140) be equal to that done by *B*. hence

$$P_1 du_1 + P_2 du_2 + \text{etc.} = dM'v'dv' + dM''v''dv'' + \text{etc.} (q)$$

Now conceive an equation like (q) written out for each of

the small consecutive displacements between positions o and n and corresponding terms to be added ; this will give

$$\int_0^n P_1 du_1 + \int_0^n P_2 du_2 + \text{etc.}$$

$$= dM' \int_0^n v' dv' + dM'' \int_0^n v'' dv'' + \text{etc.}$$

$$= \frac{1}{2} dM'(v_n'^2 - v_0'^2) + \frac{1}{2} dM''(v_n''^2 - v_0''^2) + \text{etc.}$$

The second member may be rewritten so as to give, finally,

$$\int_0^n P_1 du_1 + \int_0^n P_2 du_2 + \text{etc.} = \Sigma(\frac{1}{2} dM v_n^2) - \Sigma(\frac{1}{2} dM v_0^2), \text{(XV.)}$$

or, in words, *the work done by the acting forces (treating a resistance as a negative working force) between any two positions is equal to the gain (or loss) in the aggregate kinetic energy of the particles of the body between the two positions.* To avoid confusion, Σ has been used instead of the sign \int in one member of (XV.), in which v_n is the final velocity of any dM (not the same for all necessarily) and v_0 the initial.

(The same method of proof can be extended to three dimensions.)

Since kinetic energy is always essentially positive, if an expression for it comes out negative as the solution of a problem, some impossible conditions have been imposed.

142. Work and Kinetic Energy in a Moving Machine.—

Defining a *mechanism* or *machine* as a series of rigid bodies jointed or connected together, so that working-forces applied to one or more may be the means of overcoming resistances occurring anywhere in the system, and also of changing the amount of kinetic energy of the moving masses, let us for simplicity consider a machine the motions of whose parts are all parallel to a plane, and let all the forces acting on any one piece, considered free, at any instant be parallel to the same plane.

Now consider each piece of the machine, or of any series of its pieces, as a free body, and write out eq. (XV.) for it between any two positions (whatever initial and final positions are

selected for the first piece, those of the others must be corresponding initial and corresponding final positions), and it will be found, on adding up corresponding members of these equations, that the terms involving those components of the mutual pressures (between the pieces considered) which are *normal* to the rubbing surfaces at any instant will cancel out, while their components tangential to the rubbing surfaces (i.e., *friction*, since if the surfaces are perfectly smooth there can be no tangential action) will appear in the algebraic addition as resistances multiplied by the distances rubbed through, *measured on the rubbing surfaces*. For example, Fig. 155, where one rotating piece both presses and rubs on another. Let the normal pressure between them at A be $R_1 = P_1$; it is a working force for the body of mass M'' , but a resistance for M' , hence the separate symbols for the numerically equal forces (action and reaction).

Similarly, the friction at A is $R_2 = P_2$; a resistance for M' , a working-force for M'' . (In some cases, of course, friction may be a resistance for both bodies.) For a small motion, A describes the small arc AA' about O' in dealing with M' , but for M'' it describes the arc AA'' about O'' , $A'A''$ being parallel to the surface of contact AD , while AB is perpen-

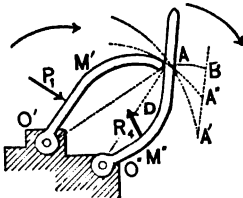

FIG. 155.

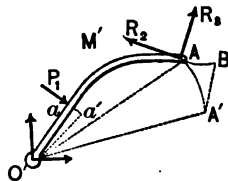

FIG. 156.

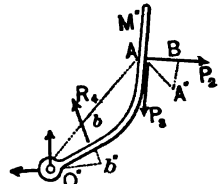

FIG. 157.

dicular to $A'A''$. In Figs. 156 and 157 we see M' and M'' free, and their corresponding small rotations indicated. During these motions the kinetic energy (K. E.) of each mass has changed by amounts $d(\text{K. E.})_{M'}$ and $d(\text{K. E.})_{M''}$, respectively, and hence eq. (XV.) gives, for each free body in turn,

$$P_1 \overline{aa'} - R_2 \overline{AB} - R_1 \overline{A'B} = d(\text{K. E.})_{M'} \quad . \quad (1)$$

$$- R_2 \overline{bb''} + P_2 \overline{AB} + P_1 \overline{A''B} = d(\text{K. E.})_{M''} \quad . \quad (2)$$

Now add (1) and (2), member to member, remembering that $P_1 = R_1$, and $P_2 = R_2 = F_1 =$ friction, and we have

$$P_1 \overline{aa'} - F_1 \overline{A'A''} - R_2 \overline{bb''} = d(\text{K. E.})_M + d(\text{K. E.})_{M'}, \quad (3)$$

in which the mutual actions of M and M' do not appear, except the friction, *the work done in overcoming which, when the two bodies are thus considered collectively, is the product of the friction by the distance $A'A''$ of actual rubbing measured on the rubbing surface.* For any number of pieces, then, considered free collectively, the assertion made at the beginning of this article is true, since any finite motion consists of an infinite number of small motions to each one of which an equation like (3) is applicable.

Summing the corresponding terms of all such equations, we have

$$\int_0^n P_1 du_1 + \int_0^n P_2 du_2 + \text{etc.} = \Sigma(\text{K. E.})_n - \Sigma(\text{K. E.})_0. \quad (\text{XVI.})$$

This is of the same form as (XV.), but instead of applying to a single rigid body, deals with any assemblage of rigid parts forming a machine, or any part of a machine (a similar proof will apply to three dimensions of space); but it must be remembered that it excludes all the *mutual* actions of the pieces considered except friction, which is to be introduced in the manner just illustrated. A flexible inextensible cord may be considered as made up of a great number of short rigid bodies jointed without friction, and hence may form part of a machine without vitiating the truth of (XVI.).

$\Sigma(\text{K. E.})_n$ signifies the sum obtained by adding the amounts of kinetic energy ($\frac{1}{2}dMv_n^2$ for each elementary mass) possessed by all the particles of all the rigid bodies at their final positions; $\Sigma(\text{K. E.})_0$, a similar sum at their initial positions. For example, the K. E. of a rigid body having a motion of translation of velocity v , $= \frac{1}{2}v^2 \int dM = \frac{1}{2}Mv^2$; that of a rigid body having an angular velocity ω about a fixed axis Z , $= \frac{1}{2}\omega^2 I_Z$ (§ 139); while, if it has an angular velocity ω about a gravity-

axis Z , which has a velocity v_z of translation at right angles to itself, the (K. E.) at this instant may be proved to be

$$\frac{1}{2}Mv_z^2 + \frac{1}{2}\omega^2 I_z,$$

i.e., is the sum of the amounts *due to the two motions separately.*

143. K. E. of Combined Rotation and Translation.—The last

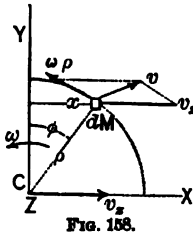

FIG. 158.

statement may be thus proved. Fig. 158. At a given instant the velocity of any dM is v , the diagonal formed on the velocity v_z of translation, and the rotary velocity $\omega\rho$ relatively to the moving gravity-axis Z (perpendicular to paper),

i.e., $v^2 = v_z^2 + (\omega\rho)^2 - 2(\omega\rho)v_z \cos \phi$;

hence we have K. E., at this instant,

$$= \int \frac{1}{2}dMv^2 = \frac{1}{2}v_z^2 \int dM + \frac{1}{2}\omega^2 \int dM\rho^2 - \omega v_z \int dM\rho \cos \phi,$$

but $\rho \cos \phi = y$, and $\int dMy = \bar{M}y = 0$, since Z is a gravity-axis,

$$\therefore \text{K. E.} = \frac{1}{2}Mv_z^2 + \frac{1}{2}\omega^2 I_z \quad \text{Q. E. D.}$$

It is interesting to notice that the K. E. due to rotation, viz., $\frac{1}{2}\omega^2 I_z = \frac{1}{2}M(\omega k)^2$, is the same as if the whole mass were concentrated in a point, line, or thin shell, at a distance k , the radius of gyration, from the axis.

144. Example of a Machine in Operation.—Fig. 159. Consider the four consecutive moving masses, M , M'' , M''' , and M^{iv} (being the piston; connecting-rod; fly-wheel, crank, drum, and chain; and weight on inclined plane) as *free*, collectively. Let us apply eq. (XVI.), the initial and final positions being taken when the crank-pin is at its dead-points o and n ; i.e., we deal with the progress of the pieces made while the crank-pin describes its upper semicircle. Remembering that the mutual actions between any two of these four masses can be left out of account (except friction), the only forces to be put in are the actions of other bodies on each one of these four, and are

shown in the figure. The only *mutual* friction considered will be at the crank-pin, and if this as an average = F' , the work done on it between o and $n = F'\pi r''$, where $r'' =$ radius of crank-pin. The work done by P , the effective steam-pressure (let it be constant) during this period is = $P_1 l'$; that done in overcoming F_1 , the friction between piston and cylinder, = $F_1 l'$; that done *upon* the weight G' of connecting-rod is cancelled by the work done *by it* in the descent following; the work done

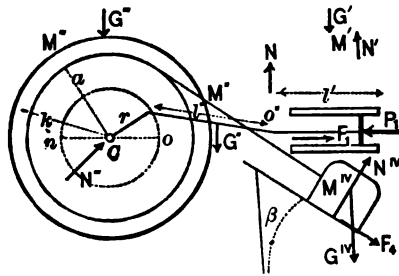

FIG. 150.

upon $G'' = G''\pi a \sin \beta$, where $a =$ radius of drum; that upon the friction $F_1 = F_1\pi a$. The pressures $N, N', N'',$ and N''' , and weights G' and G'' , are neutral, i.e., do no work either positive or negative. Hence the left-hand member of (XVI.) becomes, between o and n ,

$$P_1 l' - F_1 l' - F' \pi r'' - G'' \pi a \sin \beta - F_1 \pi a, \dots (1)$$

provided the respective distances are *actually described* by these forces, i.e., if the masses have sufficient initial kinetic energy to carry the crank-pin beyond the point of minimum velocity, with the aid of the working force P_1 , whose effect is small up to that instant.

As for the total initial kinetic energy, i.e., $\Sigma(\text{K. E.})_o$, let us express it in terms of the velocity of crank-pin at o , viz., V_o . The (K.E.) of M^o is nothing; that of $M^{o'}$, which at this instant is rotating about its right extremity (*fixed* for the instant) with angular velocity $\omega' = V_o \div l'$, is $\frac{1}{2} \omega'^2 I_{o'}$; that of $M^{o''}$ = $\frac{1}{2} \omega''^2 I_C$, in which $\omega'' = V_o \div r$; that of $M^{o''}$ (translation) = $\frac{1}{2} M^{o''} v_o^2$, in which $v_o = (a \div r) V_o$. $\Sigma(\text{K. E.})_o$ is expressed

in a corresponding manner with V_n (final velocity of crank-pin) instead of V_o . Hence the right-hand member of (XVI.) will give (putting the radius of gyration of M'' about $O'' = k''$, and that of M''' about $C = k$)

$$\frac{1}{2}(V_n^2 - V_o^2) \left[M'' \frac{k''^2}{l'^2} + M''' \frac{k^2}{r^2} + M^{iv} \frac{a^2}{r^2} \right]. \dots (2)$$

By writing (1)=(2), we have an equation of condition, capable of solution for any one unknown quantity, to be satisfied for the extent of motion considered. It is understood that the chain is always taut, and that its weight and mass are neglected.

145. Numerical Case of the Foregoing.—(Foot-pound-second system of units for space, force, and time; this requires $g = 32.2$.)

Suppose the following data :

FEET.	LS.	LS.	MASS UNITS.
$l' = 2.0$	$P_1 = 6000$	$G' = 60$	(and ∴) $M' = 1.86$
$l'' = 4.0$	$F_1 = 200$	$G'' = 50$	$M'' = 1.55$
$a = 1.5$	F'' (av'ge) = 400	$G''' = 400$	$M''' = 12.4$
$r = 1.0$	$F_2 = 800$	$G^{iv} = 3220$	$M^{iv} = 100.0$
$k = 1.8$			
$k'' = 2.8$			
$r'' = 0.1$			
Also let $V_o = 4$ ft. per sec.; $\beta = 30^\circ$			

Denote (1) by W and the large bracket in (2) by \overline{M} (this by some is called the total mass “reduced” to the crank-pin). Putting (1) = (2) we have, solving for the unknown V_n ,

$$V_n = \sqrt{\frac{2W}{\overline{M}} + V_o^2} \dots \dots \dots (3)$$

For above values,

$$W = 12,000 - 400 - 125.7 - 7590.0 - 1417.3 = 2467 \text{ foot-pounds;}$$

while $\overline{M} = 0.5 + 40.3 + 225.0 = 265.8$ mass-units;

whence

$$V_n = \sqrt{18.56 + 16} = \sqrt{34.56} = 5.88 \text{ ft. per second.}$$

As to whether the crank-pin actually reaches the dead-point n , requires separate investigations to see whether V becomes zero or negative between o and n (a negative value is inadmissible, since a reversal of direction implies a different value for W), i.e., whether the proposed extent of motion is realized; and these are made by assigning some other intermediate position m , as a final one, and computing V_m , remembering that when m is not a dead-point the (K. E.) _{m} of M' is not zero, and must be expressed in terms of V_m , and that the (K. E.) _{m} of the connecting-rod M' must be obtained from § 143.

146. Regulation of Machines.—As already illustrated in several examples (§ 121), a fly-wheel of sufficient weight and radius may prevent too great fluctuation of speed in a single stroke of an engine; but to prevent a permanent change, which must occur if the work of the working force or forces (such as the steam-pressure on a piston, or water-impulse in a turbine) exceeds for several successive strokes or revolutions the work required to overcome resistances (such as friction, gravity, resistance at the teeth of saws, etc., etc.) through their respective spaces, automatic governors are employed to diminish the working force, or the distance through which it acts per stroke, until the normal speed is restored; or *vice versa*, if the speed slackens, as when new resistances are temporarily brought into play. Hence when several successive periods, strokes (or other cycle), are considered, the kinetic energy of the moving parts will disappear from eq. (XVI.), leaving it in this form:

$$\text{work of working-forces} = \text{work done upon resistances.}$$

147. Power of Motors.—In a mill where the same number of machines are run continuously at a constant speed proper for their work, turning out per hour the same number of barrels of flour, feet of lumber, or other commodity, the motor (e.g., a steam-engine, or turbine) works at a constant rate, i.e., develops a definite horse-power (H.P.), which is thus found in the case of *steam-engines* (double-acting):

$$\text{H.P.} = \left. \begin{array}{l} \text{total mean effective} \\ \text{steam-pressure on} \\ \text{piston in lbs.} \end{array} \right\} \times \left\{ \begin{array}{l} \text{distance in feet} \\ \text{travelled by pis-} \\ \text{ton per second.} \end{array} \right\} \div 550,$$

i.e., the work (in ft.-lbs) done per second by the working force divided by 550 (see § 132). The total effective pressure at any instant is the excess of the forward over the back-pressure, and by its mean value (since steam is usually used expansively) is meant such a value P' as, multiplied by the length of stroke l , shall give

$$P'l = \int_0^l P dx,$$

where P is the variable effective pressure and dx an element of its path. If u is the number of strokes per second, we may also write (*foot-pound-second system*)

$$\text{H.P.} = P'lu \div 550 = \left[\int_0^l P dx \right] u \div 550. \quad (\text{XVII.})$$

Very often the number of revolutions *per minute*, m , of the crank is given, and then

$$\text{H.P.} = P' (\text{lbs.}) \times 2l (\text{feet}) \times m \div 33,000.$$

If F = area of piston we may also write $P' = Fp'$, where p' is the mean effective steam-pressure per unit of area. Evidently, to obtain P' in lbs., we multiply F in sq. in. by p' in lbs. per sq. in., or F in sq. ft. by p' in lbs. per sq. foot; the former is customary. p' in practice is obtained by measurements and computations from "indicator-cards" (see § 135, in which $(P_s - R_s)$ corresponds to P of this section); or $P'l$, i.e., $\int_0^l P dx$, may be computed theoretically as in § 59, Problem 4.

The power as thus found is expended in overcoming the friction of all moving parts (which is sometimes a large item), and the resistances peculiar to the kind of work done by the machines. The work periodically *stored* in the increased kinetic energy of the moving masses is *restored* as they periodically resume their minimum velocities.

148. Potential Energy.—There are other ways in which work or energy is stored and then restored, as follows:

First. In raising a weight G through a height h , an amount of work $= Gh$ is done upon G , as a *resistance*, and if at any subsequent time the weight is allowed to descend through the same vertical distance h (the form of path is of no account), G , now a *working force*, does the work Gh , and thus in aiding the motor repays, or restores, the Gh expended by the motor in raising it. If h is the vertical height through which the centre of gravity rises and sinks periodically in the motion of the machine, the force G may be left out of account in reckoning the expenditure of the motor's work, and the body when at its highest point is said to possess an amount Gh of **potential energy**, i.e., *energy of position*, since it is capable of doing the work Gh in sinking through its vertical range of motion.

Second. So far, all bodies considered have been by express stipulation *rigid*, i.e., incapable of changing shape. To see the effect of a lack of rigidity as affecting the principle of work and energy in machines, take the simple case in Fig. 160.

A helical spring at a given instant is acted on at each end by a force P in an axial direction (they are equal, supposing the

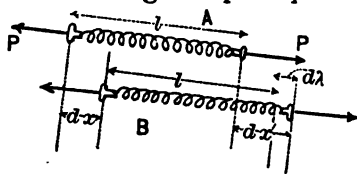

FIG. 160.

mass of the spring small). As the machine operates of which it is a member, it moves to a new consecutive position B , suffering a further elongation $d\lambda$ in its length (if P is increasing). P on the right, a working force, does the work Pdx' ; how is this expended? P on the left has the work Pdx done upon it, and the mass is too small to absorb kinetic energy or to bring its weight into consideration. The remainder, $Pdx' - Pdx = Pd\lambda$, is expended in stretching the spring an additional amount $d\lambda$, and is capable of restoration if the spring retains its elasticity. Hence the work done in changing the form of bodies *if they are elastic* is said to be stored in the form of **potential energy**. That is, in the operation of machines, the name *potential energy* is also given to the energy

stored and restored periodically in the changing and regaining of form of elastic bodies.

149. Other Forms of Energy.—Numerous experiments with various kinds of apparatus have proved that for every 772 (about) ft.-lbs. of work spent in overcoming friction, one British unit of heat is produced (viz., the quantity of heat necessary to raise the temperature of one pound of water from 32° to 33° Fahrenheit); while from converse experiments, in which the amount of heat used in operating a steam-engine was all carefully estimated, the disappearance of a certain portion of it could only be accounted for by assuming that it had been converted into work at the same rate of (about) 772 ft.-lbs. of work to each unit of heat (or 425 kilogrammetres to each French unit of heat). This number 772, or 425, according to the system of units employed, is called the *Mechanical Equivalent of Heat*, first discovered by Joule and confirmed by Hirn.*

Heat then is energy, and is supposed to be of the kinetic form due to the rapid motion or vibration of the molecules of a substance. A similar agitation among the molecules of the (hypothetical) ether diffused through space is supposed to produce the phenomena of light, electricity, and magnetism. Chemical action being also considered a method of transforming energy (its possible future occurrence as in the case of coal and oxygen being called potential energy), the well-known doctrine of the *Conservation of Energy*, in accordance with which energy is indestructible, and the doing of work is simply the conversion of one or more kinds of energy into equivalent amounts of others, is now one of the accepted hypotheses of physics.

Work consumed in friction, though practically lost, still remains in the universe as heat, electricity, or some other subtle form of energy.

150. Power Required for Individual Machines. Dynamometers of Transmission.—If a machine is driven by an endless belt from the main-shaft, *A*, Fig. 161, being the driving-pulley

* Prof. Rowland's recent experiments result in the value 429.8 kilogrammetres at a temperature of 5° Cent.

on the machine, the working force which drives the machine, in other words the "grip" with which the belt takes hold of the pulley tangentially, $= P - P'$, P and P' being the tensions in the "driving" and "following" sides of the belt respectively. The belt is supposed not to slip on the pulley. If v is the velocity of the pulley-circumference, the work expended on the machine per second, i.e., the *power*, is

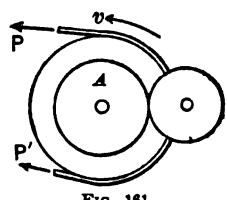

FIG. 161.

$$L = (P - P')v. \dots \dots (1)$$

To measure the force $(P - P')$, an apparatus called a *Dynamometer of Transmission* may be placed between the main shaft and the machine, and the belt made to pass through it in such a way as to measure the tensions P and P' , or principally their difference, without meeting any resistance in so doing; that is, the power is *transmitted*, not absorbed, by the apparatus. One invention for this purpose (mentioned in the *Journal of the Franklin Institute* some years ago) is shown

(*in principle*) in Fig. 162. A vertical plate carrying four pulleys and a scale-pan is first balanced on the pivot C . The belt being then adjusted, as shown, and the power turned on, a sufficient weight G is placed in the scale-pan to balance the plate again, for whose equilibrium we must have $Gb = Pa - P'a$, since the P and P' on the right are purposely given no leverage about C . The velocity of belt, v , is obtained by a simple counting device.

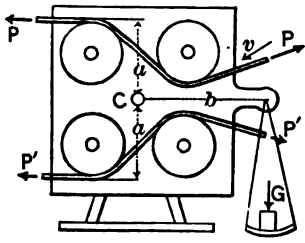

FIG. 162.

Hence $(P - P')$ and v become known, and $\therefore L$ from (1).

Many other forms of transmission-dynamometers are in use, some applicable whether the machine is driven by belting or gearing from the main shaft. Emerson's *Hydrodynamics* describes his own invention on p. 283, and gives results of measurements with it; e.g., at Lowell, Mass., the power required to drive 112 looms, weaving 36-inch sheetings, No. 20 yarn.

60 threads to the inch, speed 130 picks to the minute, was found to be 16 H.P., i.e., $\frac{1}{4}$ H.P. to each loom (p. 335).

151. Dynamometers of Absorption.—These are so named since they furnish in themselves the resistance (friction or a weight) in the overcoming (or raising) of which the power is expended or absorbed. Of these the *Prony Friction Brake* is the most common, and is used for measuring the power developed by a given motor (e.g., a steam-engine or turbine) not absorbed in the friction of the motor itself. Fig. 163

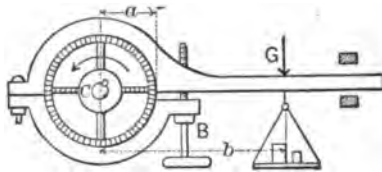

FIG. 163.

shows one fitted to a vertical pulley driven by the motor. By tightening the bolt *B*, the velocity *v* of pulley-rim may be made constant at any desired value (within certain limits) by the consequent friction. *v* is measured by a counting apparatus, while the friction (or *tangential* components of action between pulley and brake), = *F*, becomes known by noting the weight *G* which must be placed in the scale-pan to balance the arm between the checks ; then

$$Fa = Gb, \dots \dots \dots (1)$$

for the equilibrium of the brake (supposing the weight of brake and scale-pan previously balanced on *C*) and the work done per unit of time, or *power*, is

$$L = Fv. \dots \dots \dots (2)$$

A “dash-pot” is frequently connected with the arm to prevent sudden oscillations. In case the pulley is horizontal, a bell-crank lever is added between the arm and the scale-pan, and then eq. (1) will contain two additional lever-arms.

152. The Indicator, used with steam and other fluid engines, is a special kind of dynamometer in which the automatic motion of a pencil describes a curve on paper whose ordinates are proportional to the fluid pressures exerted in the cylinder at successive points of the stroke. Thus, Fig. 164, the back-pressure being constant and = P_b , the ordinates P_0, P_1 , etc., represent the effective pressures at equally spaced points of division. The mean effective pressure P' (see § 147) is, for this figure, by Simpson's Rule (six equal spaces),

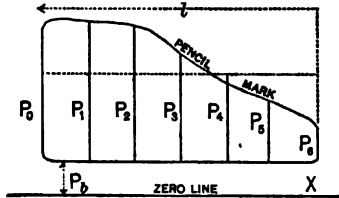

FIG. 164.

$$P' = \frac{1}{18}[P_0 + 4(P_1 + P_3 + P_5) + 2(P_2 + P_4) + P_6].$$

This gives a near approximation. The power is now found by § 147.

153. The theory of **Atwood's Machine** is most directly expressed by the principle of work and energy; i.e., by eq.

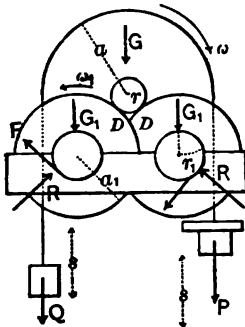

FIG. 165.

(XVI.), § 142. Fig. 165. The parts considered free, collectively, are the rigid bodies P, Q, G , and four friction-wheels like G_1 ; and the flexible cord, which does not slip on the upper pulley. There is no slipping at D , hence no sliding friction there. The actions of external bodies on these eight consist of the working force P , the resistances Q and the four F 's (at bearings of friction-wheel axles); all others ($G, 4G_1$, and the four R 's) are neutral. Since there is no rubbing between any two of the eight bodies, no mutual actions whatever will enter the equation. Let $P > Q$, and I and I_1 be the moments of inertia of G and G_1 , respectively, about their respective axes of figure. Let the apparatus start from rest, then when P has descended through any vertical distance s , and ac-

quired the velocity v , Q has been drawn up an equal distance and acquired the same velocity, while the pulley G has acquired an angular velocity $\omega = v \div a$, each friction-pulley an angular velocity $\omega_1 = (r : a)v \div a_1$. As to the forces, P has done the work Ps , Q has had the work Qs done upon it, while each F has been overcome through the space $(r_1 : a_1)(r : a)s$; all the other forces are neutral. Hence, from eq. (XVI.), § 142 (see also § 139), we have

$$Ps - Qs - 4F \frac{r_1}{a_1} \cdot \frac{r}{a} s = \left[\frac{P}{g} + \frac{Q}{g} \right] \frac{v^2}{2} + \frac{1}{2} \frac{v^2}{a^2} I + \frac{1}{2} \cdot \frac{r^2}{a^2} \cdot \frac{v^2}{a_1^2} 4I_1 - 0.$$

Evidently $v = \sqrt{s} \times \text{constant}$, i.e., the motion of P and Q is uniformly accelerated. If, after the observed space s has been described, P is suddenly diminished to such a value P' that the motion continues with a constant velocity $= v$, we shall have, for any further space s' ,

$$P's' - Qs' - 4F \frac{r_1}{a_1} \cdot \frac{r}{a} s' = 0,$$

from which F can be obtained (nearly); while if t' be the observed time of describing s' , $v = s' \div t'$ becomes known. Also we may write $I = (G \div g)k^2$ and $I_1 = (G_1 \div g)k_1^2$, and thus finally compute the acceleration of gravity, g , from our first equation above.

154. Boat-Rowing.—Fig. 166. During the stroke proper, let P = mean pressure on one oar-handle; hence the pressures on the foot-rest are $2P$, resistances. Let M = mass of boat and load, v_1 and v_2 its velocities at beginning and end of stroke. P_1 = pressures between oar-blade and water. R = mean resistance of water to the boat's passage at this (mean) speed. These are the only (horizontal) forces to be considered as acting on the boat and two oars, considered free collectively. During the stroke the boat describes the space $s_1 = CD$, the oar-handle the space $s_2 = AB$, while the oar-blade slips back-

ward through the small space (the "slip") = s , (average). Hence by eq. (XVI.), § 142,

$$2P_s - 2P_s - R_s - 2P_1s_1 = \frac{1}{2}M(v_n^2 - v_o^2);$$

$$\text{i.e., } 2P(s_1 - s) = 2P \times \overline{AE} = 2Ps = R_s + 2P_1s_1 + \frac{1}{2}M(v_n^2 - v_o^2);$$

or, in words, the product of the oar-handle pressures into the distance described by them *measured on the boat*, i.e., the work done by these pressures *relatively to the boat*, is entirely accounted for in the work of slip and of liquid-resistance, and in-

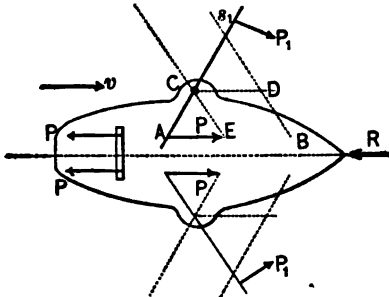

FIG. 106.

creasing the kinetic energy of the mass. (The useless work due to slip is inevitable in all paddle or screw propulsion, as well as a certain amount lost in machine-friction, not considered in the present problem.) During the "recover" the velocity decreases again to v_o .

155. Examples.—1. What work is done on a level track, in bringing up the velocity of a train weighing 200 tons, from zero to 30 miles per hour, if the total frictional resistance (at any velocity, say) is 10 lbs. per ton, and if the change of speed is accomplished in a length of 3000 feet?

(*Foot-ton-second system.*) 30 miles per hour = 44 ft. per sec. The mass

$$= 200 \div 32.2 = 6.2;$$

\therefore the change in kinetic energy,

$$\begin{aligned} & (= \frac{1}{2}Mv^2 - \frac{1}{2}M \times 0^2), \\ & = \frac{1}{2}(6.2) \times 44^2 = 6001.6 \text{ ft.-tons.} \end{aligned}$$

The work done in overcoming friction = Fs , i.e.,
 $= 200 \times 10 \times 3000 = 6,000,000$ ft.-lbs. = 3000 ft.-tons ;
 \therefore total work $= 6001.6 + 3000 = 9001.6$ ft.-tons.

(If the track were an up-grade, 1 in 100 say, the item of $200 \times 30 = 6000$ ft.-tons would be added.)

Example 2.—Required the rate of work, or power, in Example 1. The power is variable, depending on the velocity of the train at any instant. Assume the motion to be uniformly accelerated, then the working force is constant; call it P . The acceleration (§ 56) will be $p = v^2 \div 2s = 1936 \div 6000 = 0.322$ ft. per sq. sec.; and since $P - F = Mp$, we have

$$P = 1 \text{ ton} + (200 \div 32.2) \times 0.322 = 3 \text{ tons,}$$

which is $6000 \div 200 = 30$ lbs. per ton of train, of which 20 is due to its inertia, since when the speed becomes uniform the work of the engine is expended on friction alone.

Hence when the velocity is 44 ft. per sec., the engine is working at the rate of $Pv = 264,000$ ft.-lbs. per sec., i.e., at the rate of 480 H. P.;

At $\frac{1}{2}$ of 3000 ft. from the start, at the rate of 240 H. P., half as much ;

At a uniform speed of 30 miles an hour the power would be simply $1 \times 44 = 44$ ft.-tons per sec. = 160 H. P.

Example 3.—The resistance offered by still water to the passage of a certain steamer at 10 knots an hour is 15,000 lbs. What power must be developed by its engines, at this uniform speed, considering no loss in "slip" nor in friction of machinery?
Ans. 461 H. P.

Example 4.—Same as 3, except that the speed is to be 15 knots (i.e., nautical miles; each = 6086 feet) an hour, assuming that the resistances are as the square of the speed (approximately true).
Ans. 1556 H. P.

Example 5.—Same as 3, except that 12% of the power is absorbed in the "slip" (i.e., in pushing aside and backwards the water acted on by the screw or paddle), and 8% in friction of machinery.
Ans. 576 H. P.

Example 6.—In Example 3, if the crank-shaft makes 60

revolutions per minute, the crank-pin describing a circle of 18 inches radius, required the average* value of the tangential component of the thrust (or pull) of the connecting-rod against the crank-pin.

Ans. 26890 lbs.

Example 7.—A solid sphere of cast-iron is *rolling* up an incline of 30° , and at a certain instant its centre has a velocity of 36 inches per second. Neglecting friction of all kinds, how much further will the ball mount the incline (see § 143)?

Ans. 0.390 ft.

Example 8.—In Fig. 163, with $b = 4$ ft. and $a = 16$ inches, it is found in one experiment that the friction which keeps the speed of the pulley at 120 revolutions per minute is balanced by a weight $G = 160$ lbs. Required the power thus measured.

Ans. 14.6 H. P.

Although in Examples 1 to 6 the steam cylinder is itself in motion, the work per stroke is still = mean effective steam-pressure on piston \times length of stroke, for this is the final form to which the separate amounts of work done by, or upon, the two cylinder heads and the two sides of the piston will reduce, when added algebraically. See § 154.

* By "average value" is meant such a value, T_m , as multiplied into the length of path described by the crank-pin per unit of time shall give the power exerted.

CHAPTER VII.

FRICITION.

156. **Sliding Friction.**—When the surfaces of contact of two bodies are perfectly smooth, the direction of the pressure or pair of forces between them is normal to these surfaces, i.e., to their tangent-plane; but when they are rough, and moving one on the other, the forces or actions between them incline away from the normal, each on the side opposite to the direction of the (relative) motion of the body on which it acts. Thus, Fig. 167, a block whose weight is G , is drawn on a rough horizontal table by a horizontal cord, the tension in which is P . On account of the roughness of one or both bodies the action of the table upon the block is a force P_1 , inclined to the normal (which is vertical in this case) at an angle $= \varphi$ away from the direction of the relative velocity v . This angle φ is called the *angle of friction*, while the tangential component of P_1 is called the *friction* $= F$. The normal component N , which in this case is equal and opposite to G the weight of the body, is called the *normal pressure*.

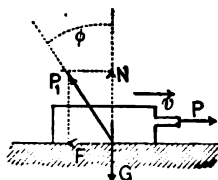

FIG. 167.

Obviously $F = N \tan \varphi$, and denoting $\tan \varphi$ by f , we have

$$F = fN. \quad \dots \dots \dots (1)$$

f is called the *coefficient of friction*, and may also be defined as the ratio of the friction F to the normal pressure N which produces it.

In Fig. 167, if the motion is accelerated ($\text{acc.} = p$), we have (eq. (IV.), § 55) $P - F = Mp$; if uniform, $P - F = 0$; from which equations (see also (1)) f may be computed. In the latter case f may be found to be different with different velocities (the surfaces retaining the same character of course), and then a uniformly accelerated motion is impossible unless $P - F$ were constant.

As for the lower block or table, forces the equals and opposites of N and F (or a single force equal and opposite to P), are comprised in the system of forces acting upon it.

As to whether F is a *working force* or a *resistance*, when either of the two bodies is considered free, depends on the circumstances of its motion. For example, in friction-gearing the tangential action between the two pulleys is a resistance for one, a working force for the other.

If the force P , Fig. 167, is just sufficient to start the body, or is just on the point of starting it (this will be called *impending motion*), F is called the *friction of rest*. If the body is at rest and P is not sufficient to start it, the tangential component will then be $<$ the friction of rest, viz., just $= P$. As P increases, this component continually equals it in value, and P acquires a direction more and more inclined from the normal, until the instant of impending motion, when the tangential component $= fN =$ the *friction of rest*. When motion is once in progress, the friction, called then the *friction of motion*, $= fN$, in which f is not necessarily the same as in the friction of rest.

157. Laws of Sliding Friction.—Experiment has demonstrated the following relations approximately, for two given rubbing surfaces: (See § 175.)

(1) The coefficient, f , is independent of the normal pressure N .

(2) The coefficient, f , for friction of motion, is the same at all velocities.

(3) The coefficient, f , for friction of rest (i.e., impending motion) is usually greater than that for friction of motion (probably on account of adhesion).

(4) The coefficient, f , is independent of the extent of rubbing surface.

(5) The interposition of an unguent (such as oil, lard, tallow, etc.) diminishes the friction very considerably.

158. Experiments on Sliding Friction.—These may be made with simple apparatus. If a block of weight = G , Fig. 168, be placed on an inclined plane of uniformly rough surface, and the latter be gradually more and more inclined from the horizontal until the block *begins* to move, the value of β at

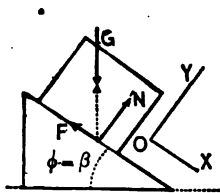

FIG. 168.

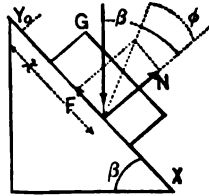

FIG. 169.

this instant = ϕ , and $\tan \phi = f =$ coefficient of friction of rest. For from $\Sigma X = 0$ we have F , i.e., fN , = $G \sin \beta$; from $\Sigma Y = 0$, $N = G \cos \beta$; whence $\tan \beta = f$, $\therefore \beta$ must = ϕ .

Suppose β so great that the motion is accelerated, the body starting from rest at o , Fig. 169. It will be found that the distance x varies as the square of the time, hence (§ 56) the motion is uniformly accelerated (along the axis X). (Notice in the figure that G is no longer equal and opposite to P , the resultant of N and F , as in Fig. 168.)

$$\Sigma Y = 0, \quad \text{which gives } N - G \cos \beta = 0;$$

$$\Sigma X = Mp, \quad \text{which gives } G \sin \beta - fN = (G \div g)p;$$

while (from § 56)

$$p = 2x \div t^2.$$

Hence, by elimination, x and the corresponding time t having been observed, we have for the coefficient of friction of motion

$$f = \tan \beta - \frac{2x}{gt^2 \cos \beta}$$

In view of (3), § 157, it is evident that if a value β_m has been found experimentally for β such that the block, *once started by hand*, preserves a uniform motion down the plane, then, since $\tan \beta_m = f$ for friction of motion, β_m may be less than the β in Fig. 168, for friction of rest.

159. Another apparatus consists of a horizontal plane, a pulley, cord, and two weights, as shown in Fig. 59. The masses of the cord and pulley being small and hence neglected, the analysis of the problem when G is so large as to cause an accelerated motion is the same as in that example [(2) in § 57], except in Fig. 60, where the frictional resistance fN should be put in pointing toward the left. N still = G_1 , and \therefore

$$S - fG_1 = (G_1 \div g)p; \dots \dots \dots (1)$$

while for the other free body in Fig. 61 we have, as before,

$$G - S = (G \div g)p. \dots \dots \dots (2)$$

From (1) and (2), S the cord-tension can be eliminated, and solving for p , writing it equal to $2s \div t^2$, s and t being the observed distance described (from rest) and corresponding time, we have finally for friction of motion

$$f = \frac{G}{G_1} - \frac{G + G_1}{G_1} \cdot \frac{2s}{gt^2} \dots \dots \dots (3)$$

If G , Fig. 59, is made just sufficient to start the block, or sledge, G_1 , we have for the friction of rest

$$f = \frac{G}{G_1} \dots \dots \dots (4)$$

160. **Results of Experiments on Sliding Friction.**—Professor Thurston in his article on Friction (which the student will do well to read) in Johnson's Cyclopædia gives the following epitome of results from General Morin's experiments (made for the French Government in 1833):

TABLE FOR FRICTION OF MOTION.

No.	Surfaces.	Unguent.	Angle ϕ .	$f = \tan \phi$.
1	Wood on wood.	None.	14° to $26\frac{1}{2}^\circ$	0.25 to 0.50
2	Wood on wood.	Soap.	2° to $11\frac{1}{2}^\circ$	0.04 to 0.20
3	Metal on wood.	None.	$26\frac{1}{2}^\circ$ to $31\frac{1}{2}^\circ$	0.50 to 0.60
4	Metal on wood.	Water.	15° to 20°	0.25 to 0.35
5	Metal on wood.	Soap.	$11\frac{1}{2}^\circ$	0.20
6	Leather on metal.	None.	$29\frac{1}{2}^\circ$	0.56
7	Leather on metal.	Greased.	18°	0.23
8	Leather on metal.	Water.	20°	0.36
9	Leather on metal.	Oil.	$8\frac{1}{2}^\circ$	0.15
10	Smoothest and best lubricated surfaces.	$1\frac{1}{2}^\circ$ to 2°	0.03 to 0.036

For friction of rest, about 40% may be added to the coefficients in the above table.

In dealing with the stone blocks of an arch-ring, ϕ is commonly taken = 30° , i.e., $f = \tan 30^\circ = 0.58$ as a low safe value; it is considered that if the direction of pressure between two stones makes an angle $> 30^\circ$ with the normal to the joint (see § 161) slipping may take place (the adhesion of cement being neglected).

General Morin states that for a sledge on dry ground $f =$ about 0.66.

Weisbach gives for metal on metal, *dry* (R. R. brakes for example), $f =$ from 0.15 to 0.24. Trautwine's Pocket-Book gives values of f for numerous cases of friction.

161. Cone of Friction.—Fig. 170. Let A and B be two rough blocks, of which B is immovable, and P the resultant of all the forces acting on A , except the pressure from B . B can furnish any required normal pressure N to balance $P \cos \beta$, but the limit of its tangential resistance is fN . So long then as β is $< \phi$ the angle of friction, or in other words, so long as the line of action of P is *within the "cone of friction"* generated by revolving OC about ON , the block A will not

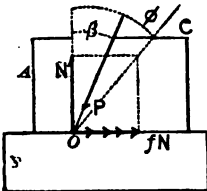

FIG. 170.

slip on B , and the tangential resistance of B is simply $P \sin \beta$; but if β is $> \varphi$, this tangential resistance being only fN and $< P \sin \beta$, A will begin to slip, with an acceleration.

162. Problems in Sliding Friction.—In the following problems f is supposed known at points where rubbing occurs, or is impending. As to the pressure N to which the friction is due, it is generally to be considered unknown until determined by the conditions of the problem. Sometimes it may be an advantage to deal with the single unknown force P (resultant of N and fN) acting in a line making the known angle φ with the normal (on the side *away* from the motion).

PROBLEM 1.—Required the value of the weight P , Fig. 171, the slightest addition to which will cause motion of the horizontal rod OB , resting on rough planes at 45° . The weight G of the rod may be applied at the middle. Consider the rod free; at each point of contact there is an unknown N and a friction due to it fN ; the tension in the cord will be $= P$, since there is no acceleration and no friction at pulley. Notice

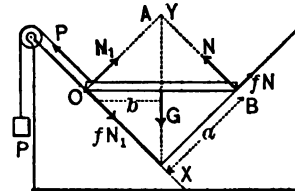

FIG. 171.

the direction of the frictions, both opposing the impending motion. [The student should not rush to the conclusion that N and N_1 are equal, and are the same as would be produced by the components of G if the latter were transferred to A and resolved along AO and AB ; but should await the legitimate results deduced by algebra, from the equations of condition for the equilibrium of a system of forces in a plane. Few problems in Mechanics are so simple as to admit of an immediate mental solution on inspection; and guess-work should be carefully avoided.]

Taking an origin and two axes as in figure, we have (eqs. (2), § 36), denoting the sine of 45° by m ,

$$\Sigma X \dots fN_1 + mG - N - P = 0; \dots (1)$$

$$\Sigma Y \dots N_1 + fN - mG = 0; \dots (2)$$

$$\Sigma(Pa) \dots fNa + Na - Gb = 0 \dots (3)$$

The three unknowns P , N , and N_1 can now be found. Divide (3) by a , remembering that $b : a = m$, and solve for N ; substitute it in (2) and N_1 also becomes known; while P is then found from (1) and is

$$P = \frac{2mfG}{1+f} = \frac{f\sqrt{2}}{1+f} \cdot G.$$

PROBLEM 2.—Fig. 172. A rod, centre of gravity at middle, leans against a rough wall, and rests on an equally rough floor;

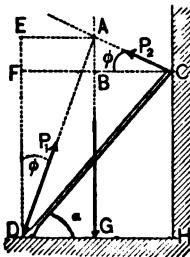

FIG. 172.

how small may the angle α become before it slips? Let $a =$ the half-length. The figure shows the rod free, and following the suggestion of § 162, a single unknown force P , making a known angle φ (whose $\tan = f$) with the normal DE , is put in at D , leaning away from the direction of the impending motion, instead of an N and fN ; similarly P_1 acts at C . The present system consisting of but three forces, the most direct method of finding α , without introducing the other two unknowns P_1 and P_2 at all, is to use the principle that if three forces balance, their lines of action must intersect in a point. That is, P_1 must intersect the vertical containing G , the weight, in the same point as P , viz., A .

Now \overline{EA} , and also \overline{BC} , $= a \cos \alpha$,

$\therefore ED = a \cos \alpha \cot \varphi$ and $AB = a \cos \alpha \tan \varphi$.

But DF , which $= 2a \sin \alpha$, $= DE - AB$;

$$\therefore 2a \sin \alpha = a \cos \alpha [\cot \varphi - \tan \varphi]. \quad \dots (1)$$

Dividing by $\cos \alpha$, and noting that $\tan \varphi = f = 1 \div \cot \varphi$, we obtain for the required value of α

$$\tan \alpha = \frac{1}{2} \cdot \frac{1-f^2}{f}; \quad \text{and finally,} \quad \tan \alpha = \cot 2\varphi,$$

after some trigonometrical reduction. That is, α is the complement of double the angle of friction.

PROBLEM 3.—Fig. 173. Given the resistance Q , acting parallel to the fixed guide C , the angle α , and the (equal) coefficients of friction at the rubbing surfaces, required the

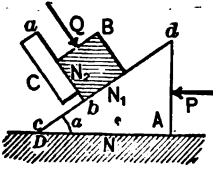

Fig. 173.

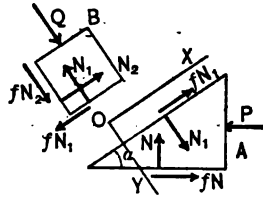

Fig. 174.

amount of the horizontal force P , at the head of the block A (or *wedge*), to overcome Q and the frictions. D is fixed, and ab is perpendicular to cd . Here we have four unknowns, viz., P , and the three pressures N , N_1 , and N_2 , between the blocks. Consider A and B as free bodies, separately (see Fig. 174), remembering Newton's law of action and reaction. The full values (e.g., fN) of the frictions are put in, since we suppose a slow uniform motion taking place.

For A , $\Sigma X = 0$ and $\Sigma Y = 0$ give

$$N_1 - N \cos \alpha + fN \sin \alpha - P \sin \alpha = 0; \dots (1)$$

$$fN_1 + N \sin \alpha + fN \cos \alpha - P \cos \alpha = 0. \dots (2)$$

For B , ΣX and ΣY give

$$Q - N_1 + fN_1 = 0; \dots (3) \quad \text{and} \quad N_2 - fN_2 = 0. \dots (4)$$

Solve (4) for N_2 and substitute in (3), whence

$$N_1(1 - f^2) = Q. \dots (5)$$

Solve (2) for N , substitute the result in (1), as also the value of N_1 from (5), and the resulting equation contains but one unknown, P . Solving for P , putting for brevity

$$f \cos \alpha + \sin \alpha = m \quad \text{and} \quad \cos \alpha - f \sin \alpha = n,$$

we have
$$P = \frac{(m + fn)Q}{(n \cdot \cos \alpha + m \cdot \sin \alpha)(1 - f^2)}. \dots (6)$$

or
$$P = Q(m + fn) \div (1 - f^2). \dots (7)$$

Numerical Example of Problem 3.—If $Q = 120$ lbs., $f = 0.20$ (an abstract number, and \therefore the same in any system of units), while $\alpha = 14^\circ$, whose sine = 0.240 and cosine = .970, then

$$m = 0.2 \times .97 + 0.24 = 0.43 \quad \text{and} \quad n = .97 - .2 \times .24 = 0.92,$$

whence

$$P = 0.64Q = 76.8 \text{ lbs.}$$

While the wedge moves 2 inches P does the work (or exerts an energy) of $2 \times 76.80 = 153.6$ in.-lbs. = 12.8 ft.-lbs.

For a distance of 2 inches described by the wedge horizontally, the block B (and \therefore the resistance Q) has been moved through a distance = $2 \times \sin 14^\circ = 0.48$ in. along the guide C , and hence the work of $120 \times 0.48 = 57.6$ in.-lbs. has been done upon Q . Therefore for the supposed portion of the motion $153.6 - 57.6 = 96.0$ in.-lbs. of work has been lost in friction (converted into heat).

It is noticeable in eq. (6), that if f should = 1.00, $P = \alpha$; and that if $\alpha = 90^\circ$, $P = Q$, and there is no friction (the weights of the blocks have been neglected).

PROBLEM 4. *Numerical.*—With what minimum pressure P should the pulley A be held against B , which it drives by “frictional gearing,” to transmit 2 H.P.; if $\alpha = 45^\circ$, f for impending (relative) motion, i.e., for impending slipping = 0.40, and the velocity of the pulley-rim

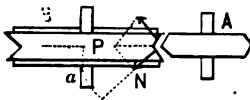

FIG. 175.

is 9 ft. per second?

The limit-value of the tangential “grip”

$$T = 2fN = 2 \times 0.40 \times P \sin 45^\circ,$$

$$2 \text{ H. P.} = 2 \times 550 = 1100 \text{ ft.-lbs. per second.}$$

Putting $T \times 9 \text{ ft.} = 1100$, we have

$$2 \times 0.40 \times \sqrt{\frac{1}{2}} \times P \times 9 = 1100; \therefore P = 215 \text{ lbs.}$$

PROBLEM 6.—A block of weight G lies on a rough plane, inclined an angle β from the horizontal; find the pull P , making an angle α with the first plane, which will maintain a uniform motion *up* the plane.

PROBLEM 7.—Same as 6, except that the pull P is to permit a uniform motion *down* the plane.

PROBLEM 8.—The thrust of a screw-propeller is 15 tons. The ring against which it is exerted has a mean radius of 8 inches, the shaft makes one revolution per second, and $f = 0.06$. Required the H. P. lost in friction from this cause.

Ans. 13.7 H. P.

163. The Bent-Lever with Friction. Worn Bearing.—Fig. 176. Neglect the weight of the lever, and suppose the plumb-

er-block so worn that there is contact along one element only of the shaft. Given the amount and line of action of the resistance R , and the line of action of P , required the amount of the latter for impending slipping in the direction of the dotted arrow. As P gradually increases, the shaft of the lever (or gear-wheel) rolls on its bearing until the line of contact has reached some position A , when rolling ceases and slipping begins.

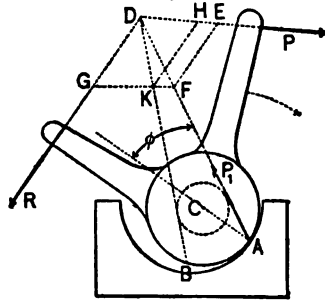

FIG. 176.

To find A , and the value of P , note that the total action of the bearing upon the lever is some force P_1 , applied at A and making a known angle φ ($f = \tan \varphi$) with the normal AC . P_1 must be equal and opposite to the resultant of the known R and the unknown P , and hence graphically (a graphic is much simpler here than an analytical solution) if we describe about C a circle of radius $= r \sin \varphi$, r being the radius of shaft (or gudgeon), and draw a tangent to it from D , we determine DA as the line of action of P_1 . If DG is made $= R$, to scale, and GF drawn parallel to D . . . P , P is determined, being $= DE$, while $P_1 = DF$.

If the known force R is capable of acting as a working force, by drawing the other tangent DB from D to the "friction-circle," we have $P = DH$, and $P_1 = DK$, for impending rotation in an opposite direction.

If R and P are the tooth-pressures upon two spur-wheels, keyed upon the same shaft and nearly in the same plane, the

same constructions hold good, and for a continuous uniform motion, since the friction = $P_1 \sin \varphi$,

$$\left. \begin{array}{l} \text{the work lost in friction} \\ \text{per revolution,} \end{array} \right\} = [P_1 \sin \varphi] 2\pi r.$$

It is to be remarked, that without friction P_1 would pass through C , and that the moments of R and P would balance about C (for rest or uniform rotation); whereas with friction they balance about the proper tangent-point of the friction-circle.

Another way of stating this is as follows: So long as the resultant of P and R falls within the "dead-angle" BDA , motion is impossible in either direction.

If the weight of the lever is considered, the resultant of it and the force R can be substituted for the latter in the foregoing.

164. Bent-Lever with Friction. Triangular Bearing.—Like the preceding, the gudgeon is much exaggerated in the figure

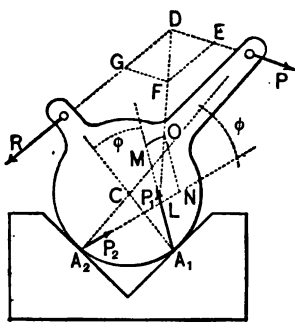

FIG. 177.

(177). For impending rotation in direction of the force P , the total actions at A_1 and A_2 must lie in known directions, making angles = φ with the respective normals, and inclined away from the slipping. Join the intersections D and L . Since the resultant of P and R at D must act along DL to balance that of P_1 and P_2 , having given one force, say R , we easily find $P = DE$, while

P_1 and $P_2 = LM$ and LN respectively, LO having been made = DF , and the parallelogram completed.

(If the direction of impending rotation is reversed, the change in the construction is obvious.) If $P_2 = 0$, the case reduces to that in Fig. 176; if the construction gives P_2 negative, the supposed contact at A_2 is not realized, and the angle A_1CA_2 should be increased, or shifted, until P_2 is positive.

As before, P and R may be the tooth-pressures on two

spur-wheels nearly in the same plane and on the same shaft; if so, then, for a uniform rotation,

$$\text{Work lost in fric. per revol.} = [P_1 \sin \varphi + P_2 \sin \varphi] 2\pi r.$$

165. Axle-Friction.—The two foregoing articles are introductory to the subject of axle-friction. When the bearing is new, or nearly so, the elements of the axle which are in contact with the bearing are infinite in number, thus giving an infinite number of unknown forces similar to P_1 and P_2 of the last paragraph, each making an angle φ with its normal. Refined theories as to the law of distribution of these pressures are of little use, considering the uncertainties as to the value of f' ($= \tan \varphi$); hence for practical purposes axle-friction may be written

$$F = f' R,$$

in which f' is a *coefficient of axle-friction* derivable from experiments with axles, and R the resultant pressure on the bearing. In some cases R may be partly due to the tightness of the bolts with which the cap of the bearing is fastened.

As before, the work lost in overcoming axle-friction *per revolution* is $= f' R 2\pi r$, in which r is the radius of the axle. f' , like f , is an abstract number. As in Fig. 176, a “friction-circle,” of radius $= f' r$, may be considered as subtending the “dead-angle.”

166. Experiments with Axle-Friction.—Prominent among recent experiments have been those of Professor Thurston (1872–73), who invented a special instrument for that purpose, shown (in principle only) in Fig. 178. By means of an internal spring, the amount of whose compression is read on a scale, a weighted bar or pendulum is caused to exert pressure on a projecting axle from which it is suspended. The axle is made to rotate at any desired

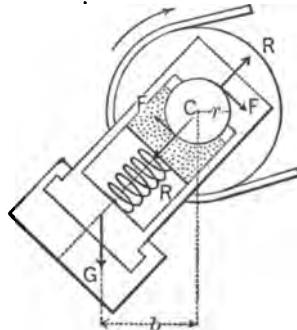

FIG. 178.

velocity by some source of power, the axle-friction causing

the pendulum to remain at rest at some angle of deviation from the vertical. The figure shows the pendulum free, the action of gravity upon it being G , that of the axle consisting of the two pressures, each = R , and of the two frictions (each being $F = f' R$), due to them. Taking moments about C , we have for equilibrium

$$2f' Rr = Gb,$$

in which all the quantities except f' are known or observed. The temperature of the bearing is also noted, with reference to its effect on the lubricant employed. Thus the instrument covers a wide range of relations.

General Morin's experiments as interpreted by Weisbach give the following practical results:

$$\text{For iron axles, in iron or } \left. \begin{array}{l} \text{brass bearings} \end{array} \right\} f' = \left\{ \begin{array}{l} 0.054 \text{ for well-sustained} \\ \text{lubrication;} \\ 0.07 \text{ to } .08 \text{ for ordinary} \\ \text{lubrication.} \end{array} \right.$$

By "pressure per square inch on the bearing" is commonly meant the quotient of the total *pressure in lbs.* by the area in *square inches* obtained by multiplying the width of the axle by the length of bearing (this length is quite commonly four times the diameter); call it p , and the velocity of rubbing in *feet per minute*, v . Then, according to Rankine, to prevent overheating, we should have

$$p(v + 20) < 44800 \dots \text{ (not homog.)}$$

Still, in marine-engine bearings $p v$ alone often reaches 60,000, as also in some locomotives (Cotterill). Good practice keeps p within the limit of 800 (lbs. per sq. in.) for other metals than steel (Thurston), for which 1200 is sometimes allowed.

With $v = 200$ (feet per min.) Professor Thurston found that for ordinary lubricants p should not exceed values ranging from 30 to 75 (lbs. per sq. in.).

The product $p v$ is obviously proportional to the power expended in wearing the rubbing surfaces, per unit of area.

167. **Friction-Wheels.**—A single example of their use will be given, with some approximations to avoid complexity. Fig. 179. G is the weight of a heavy wheel, P_1 is a known vertical resistance (tooth-pressure), and P an unknown vertical working force, whose value is to be determined to maintain a uniform rotation. The utility of the friction-wheels is also to be shown. The resultant of P_1 , G , and P is a vertical force R , passing nearly through the centre C of the main axle which rolls on the four friction-wheels. R , resolved along CA and CB , produces (nearly) equal pressures, each being $N = R \div 2 \cos \alpha$, at the two axes of the friction-wheels, which rub against their fixed plumber-blocks. $R = P + P_1 + G$, and \therefore contains the unknown P , but approximately $= G + 2P_1$, i.e., is nearly the same (in this case) whether friction-wheels are employed or not.

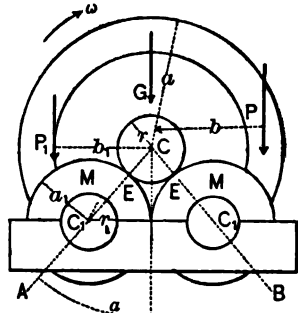

FIG. 179.

When G makes one revolution, the friction $f^r N$ at each axle C_1 is overcome through a distance $= (r_1 : a_1) 2\pi r$, and

$$\left. \begin{array}{l} \text{Work lost per revol.} \\ \text{with} \\ \text{friction-wheels,} \end{array} \right\} = 2 f^r N \frac{r_1}{a_1} 2\pi r = \frac{r_1}{a_1} \frac{1}{\cos \alpha} f^r R 2\pi r.$$

Whereas, if C revolved in a fixed bearing,

$$\left. \begin{array}{l} \text{Work lost per revol.} \\ \text{without} \\ \text{friction-wheels,} \end{array} \right\} = f^r R 2\pi r.$$

Apparently, then, there is a saving of work in the ratio $r_1 : a_1 \cos \alpha$, but strictly the R is not quite the same in the two cases; for with friction-wheels the force P is less than without, and R depends on P as well as on the known G and P_1 . By diminishing the ratio $r_1 : a_1$, and the angle α , the saving is increased. If α were so large that $\cos \alpha < r_1 : a_1$, there would be no saving, but the reverse.

As to the value of P to maintain uniform rotation, we have

for equilibrium of moments about C , with friction-wheels (considering the large wheel and axle *free*),

$$Pb = P_1b_1 + 2Tr, \dots \dots \dots (1)$$

in which T is the tangential action, or "grip," between one pair of friction-wheels and the axle C which rolls upon them. T would not equal fN unless slipping took place or were impending at E , but is known by considering a pair of friction-wheels free, when $\Sigma(Pa)$ about C_1 gives

$$Ta_1 = fNr_1 = f \frac{R}{2} \cdot \frac{r_1}{\cos \alpha},$$

which in (1) gives finally

$$P = \frac{b_1}{b}P_1 + \frac{r_1}{a_1 \cos \alpha} f R \frac{r}{b} \dots \dots \dots (2)$$

Without friction-wheels, we would have

$$P = \frac{b_1}{b}P_1 + f R \frac{r}{b} \dots \dots \dots (3)$$

The last term in (2) is seen to be less than that in (3) (unless α is too large), in the same ratio as already found for the saving of work, supposing the R 's equal.

If P_1 were on the same side of C as P , it would be of an opposite direction, and the pressure R would be diminished. Again, if P were horizontal, R would not be vertical, and the friction-wheel axles would not bear equal pressures. Since P depends on P_1 , G , and the frictions, while the friction depends on R , and R on P_1 , G , and P , an exact analysis is quite complex, and is not warranted by its practical utility.

Example.—If an empty vertical water-wheel weighs 25,000 lbs., required the force P to be applied at its circumference to maintain a uniform motion, with $a = 15$ ft., and $r = 5$ inches. Here $P_1 = 0$, and $R = G$ (nearly; neglecting the influence of P on R), i.e., $R = 25,000$ lbs.

First, without friction-wheels (adopting the foot-pound-second system of units), with $f = .07$ (abstract number). From eq. (3) we have

$$P = 0 + 0.07 \times 25,000 \times \left(\frac{5}{12} \div 15\right) = 48.6 \text{ lbs.}$$

The work lost in friction per revolution is

$$fR2\pi r = 0.07 \times 25,000 \times 2 \times 3.14 \times \frac{5}{12} = 4580 \text{ ft.-lbs.}$$

Secondly, with friction-wheels, in which $r_1 : a_1 = \frac{1}{4}$ and $\cos \alpha = 0.80$ (i.e., $\alpha = 36^\circ$). From eq. (2)

$$P = 0 + \frac{1}{4} \cdot \frac{1}{8} \times 48.6 = \text{only } 12.15 \text{ lbs.,}$$

while the work lost per revolution

$$= \frac{1}{4} \cdot \frac{1}{8} \times 4580 = 1145 \text{ ft.-lbs.}$$

Of course with friction-wheels the wheel is not so steady as without.

In this example the force P has been simply enough to overcome friction. In case the wheel is in actual use, P is the weight of water actually in the buckets at any instant, and does the work of overcoming P , the resistance of the mill machinery, and also the friction. By placing P , pointing upward on the same side of C as P , and making b , nearly = b , R will = G nearly, just as when the wheel is running empty; and the foregoing numerical results will still hold good for practical purposes.

168. Friction of Pivots.—In the case of a vertical shaft or axle, and sometimes in other cases, the extremity requires support against a thrust along the axis of the axle or pivot. If the end of the pivot is *flat* and also the surface against which it rubs, we may consider the pressure, and therefore the friction, as uniform over the surface. With a flat circular pivot, then, Fig. 180, the frictions on a small sector of the circle form a system of parallel forces whose resultant is equal to their sum, and is applied a distance of $\frac{2}{3}r$ from the centre. Hence the sum of the moments of all the frictions about the centre = $fR\frac{2}{3}r$, in which R is the axial pressure. Therefore a force P necessary to overcome the friction with uniform rotation must have a moment

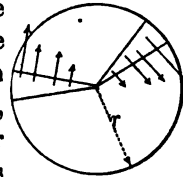

FIG. 180.

$$Pa = fR\frac{2}{3}r.$$

and the work lost in friction per revolution is

$$= fR2\pi \cdot \frac{2}{3}r = \frac{4}{3}\pi fRr. \dots (1)$$

As the pivot and step become worn, the resultant frictions in the small sectors probably approach the centre; for the greatest wear occurs first near the outer edge, since there the product pv is greatest (see § 166). Hence for $\frac{2}{3}r$ we may more reasonably put $\frac{1}{3}r$.

Example.—A vertical flat-ended pivot presses its step with a force of 12 tons, is 6 inches in diameter, and makes 40 revolutions per minute. Required the H. P. absorbed by the friction. Supposing the pivot and step new, and f for good lubrication = 0.07, we have, from eq. (1) (*foot-lb.-second*),

Work lost per revolution

$$= .07 \times 24,000 \times 6.28 \times \frac{2}{3} \cdot \frac{1}{3} = 1758.4 \text{ ft.-lbs.,}$$

and \therefore work per second

$$= 1758.4 \times \frac{40}{60} = 1172.2 \text{ ft.-lbs.,}$$

which $\div 550$ gives 2.13 H. P. absorbed in friction. If ordinary axle-friction also occurs its effect must be added.

If the flat-ended pivot is *hollow*, with radii r_1 and r_2 , we may put $\frac{1}{2}(r_1 + r_2)$ instead of the $\frac{2}{3}r$ of the preceding.

It is obvious that the smaller the lever-arm given to the resultant friction in each sector of the rubbing surface the smaller the power lost in friction. Hence pivots should be made as small as possible, consistently with strength.

For a *conical pivot* and step, Fig. 181, the resultant friction

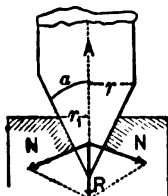

FIG. 181.

in each sector of the conical bearing surface has a lever-arm = $\frac{2}{3}r_1$, about the axis A , and a value $>$ than for a flat-ended pivot; for, on account of the wedge-like action of the bodies, the pressure causing friction is greater. The sum of the moments of these resultant frictions about A is the same as if only two elements of the cone received pressure (each = $N = \frac{1}{2}R \div \sin \alpha$). Hence the

moment of friction of the pivot, i.e., the moment of the force necessary to maintain uniform rotation, is

$$Pa = f2N\frac{2}{3}r_1 = f\frac{R}{\sin \alpha}\frac{2}{3}r_1,$$

and work lost per revolution = $\frac{4}{3}\pi f\frac{R}{\sin \alpha}r_1.$

By making r_1 small enough, these values may be made less than those for a flat-ended pivot of the same diameter = $2r$.

In Schiele's "anti-friction" pivots the outline is designed according to the following theory for securing uniform vertical wear. Let p = the pressure per horizontal unit of area (i.e., = $R \div$ horizontal projection of the *actual rubbing surface*); this is assumed constant. Let the unit of area be small, for algebraic simplicity. The friction on the rubbing surface, whose horizontal projection = unity, is = $fN = f(p \div \sin \alpha)$ (see Fig. 182; the horizontal component of p is annulled by a corresponding one opposite). The work per revolution in producing wear on this area = $fN2\pi y$. But the *vertical depth* of wear per revolution is to be the same at all parts of the surface; and this implies that the same volume of material is worn away under each horizontal unit of area. Hence $fN2\pi y$, i.e., $f\frac{p}{\sin \alpha}2\pi y$, is to be constant for all values of y ; and since fp and 2π are constant, we must have, as the law of the curve,

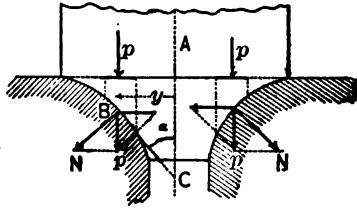

FIG. 182.

$$\frac{y}{\sin \alpha}, \text{ i.e., the tangent } BC = \text{the same at all points.}$$

This curve is called the "*tractrix*." Schiele's pivots give a very uniform wear at high speeds. The smoothness of wear prevents leakage in the case of cocks and faucets.

169. Normal Pressure of Belting.—When a perfectly flexible cord, or belt, is stretched over a smooth cylinder, both at rest,

the action between them is normal at every point. As to its amount, p , per linear unit of arc, the following will determine. Consider a semi-circle of the cord free, neglecting its weight. Fig. 183. The forces holding it in equilibrium are the tensions at the two ends (these are equal, manifestly, the cylinder being smooth; for they are the only two forces having moments about C , and each has the same lever-arm), and the normal pressures,

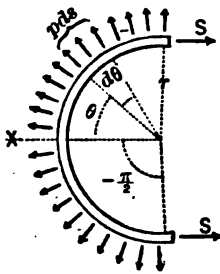

FIG. 183.

which are infinite in number, but have an intensity, p , per linear unit, which must be constant along the curve since S is the same at all points. The normal pressure on a single element, ds , of the cord is $p ds$, and its X component $= p ds \cos \theta = pr d\theta \cos \theta$. Hence $\sum X = 0$ gives

$$rp \int_{-\pi}^{+\pi} \cos \theta d\theta - 2S = 0, \text{ i.e., } rp \left[\sin \theta \right]_{-\pi}^{+\pi} = 2S;$$

$$\therefore rp[1 - (-1)] = 2S \text{ or } p = \frac{S}{r} \dots \dots (1)$$

170. Belt on Rough Cylinder. Impending Slipping.—If friction is possible between the two bodies, the tension may vary along the arc of contact, so that p also varies, and consequently

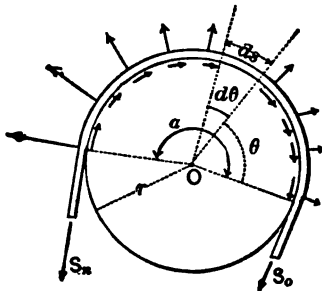

FIG. 184.

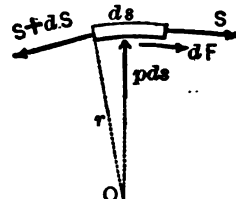

FIG. 185.

the friction on an element ds being $= fp ds = f(S \div r) ds$, also varies. If *slipping is impending*, the law of variation of the tension S may be found, as follows: Fig. 184, in which the

impending slipping is toward the left, shows the cord free. For any element, ds , of the cord, we have, putting Σ (moments about O) = 0 (Fig. 185),

$$(S + dS)r = Sr + dFr; \text{ i.e., } dF = dS,$$

or (see above) $dS = f(S \div r)ds$.

But $ds = rd\theta$; hence, after transforming,

$$fd\theta = \frac{dS}{S}. \dots \dots \dots (1)$$

In (1) the two variables θ and S are separated; (1) is therefore ready for integration.

$$\therefore f \int_0^\alpha d\theta = \int_{S_0}^{S_n} \frac{dS}{S}; \text{ i.e.,}$$

$$f\alpha = \log_e S_n - \log_e S_0 = \log_e \left[\frac{S_n}{S_0} \right]. \quad (2)$$

Or, by inversion, $S_0 e^{f\alpha} = S_n, \dots \dots \dots (3)$

e , denoting the Napierian base, = 2.71828 +; α of course is in π -measure.

Since S_n evidently increases very rapidly as α becomes larger, S_0 remaining the same, we have the explanation of the well-known fact that a comparatively small tension, S_0 , exerted by a man, is able to prevent the slipping of a rope around a pile-head, when the further end is under the great tension S_n due to the stopping of a moving steamer. For example, with $f = \frac{1}{3}$, we have (Weisbach)

- for $\alpha = \frac{1}{2}$ turn, or $\alpha = \frac{1}{2}\pi, S_n = 1.69S_0;$
- $= \frac{1}{3}$ turn, or $\alpha = \pi, S_n = 2.85S_0;$
- $= 1$ turn, or $\alpha = 2\pi, S_n = 8.12S_0;$
- $= 2$ turns, or $\alpha = 4\pi, S_n = 65.94S_0;$
- $= 4$ turns, or $\alpha = 8\pi, S_n = 4348.56S_0.$

If slipping actually occurs, we must use a value of f for friction of motion.

Example.—A leather belt drives an iron pulley, covering one half the circumference. What is the limiting value of the

ratio of S_n (tension on driving-side) to S_f (tension on following side) if the belt is not to slip, taking the low value of $f = 0.25$ for leather on iron?

We have given $f\alpha = 0.25 \times \pi = .7854$, which by eq. (2) is the Napierian log. of $(S_n : S_f)$ when slipping occurs. Hence the common log. of $(S_n : S_f) = 0.7854 \times 0.43429 = 0.34109$; i.e., if

$$(S_n : S_f) = 2.193, \text{ say } 2.2,$$

the belt will slip (for $f = 0.25$).

(0.43429 is the modulus of the common system of logarithms, and $= 1 : 2.30258$. See example in § 48.)

At very high speeds the relation $p = S \div r$ (in § 169) is not strictly true, since the tensions at the two ends of an element ds are partly employed in furnishing the necessary deviating force to keep the element of the cord in its circular path, the remainder producing normal pressure.

171. Transmission of Power by Belting or Wire Rope.—In the simple design in Fig. 186, it is required to find the *motive weight* G , necessary to overcome the given resistance R at a

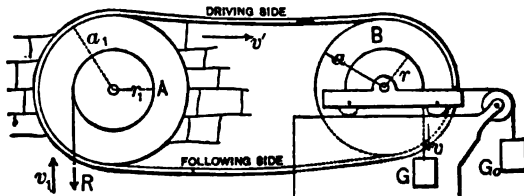

FIG. 186.

uniform velocity $= v$; also the proper stationary *tension weight* G_0 to prevent slipping of the belt on its pulleys, and the amount of power, L , transmitted.

In other words,

Given : $\left\{ \begin{array}{l} R, a, r, a_1, r_1; \alpha = \pi \text{ for both pulleys,} \\ v; \text{ and } f \text{ for both pulleys;} \end{array} \right\}$

Required : $\left\{ \begin{array}{l} L; G, \text{ to furnish } L; G_0 \text{ for no slip;} \\ \text{of } G; v' \text{ that of belt; and the tensions in belt.} \end{array} \right\}$

Neglecting axle-friction and the rigidity of the belting, the power transmitted is that required to overcome R through a distance = v_1 every second, i.e.,

$$L = Rv_1. \quad \dots \dots \dots (1)$$

Since (if the belts do not slip)

$$a : r :: v' : v, \quad \text{and} \quad a_1 : r_1 :: v' : v_1,$$

we have
$$v' = \frac{a_1}{r_1}v_1, \quad \text{and} \quad v = \frac{r}{a} \frac{a_1}{r_1}v_1. \quad \dots \dots \dots (2)$$

Neglecting the mass of the belt, and assuming that each pulley revolves on a gravity-axis, we obtain the following, by considering the free bodies in Fig. 187:

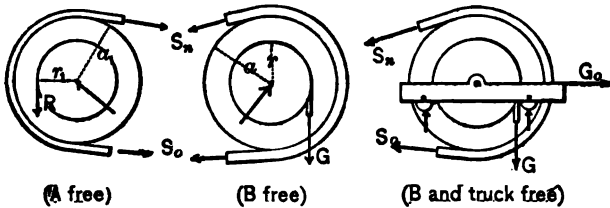

FIG. 187.

$$\Sigma (\text{moms.}) = 0 \text{ in } A \text{ free gives } Rr_1 = (S_n - S_o)a; \quad (3)$$

$$\Sigma (\text{moms.}) = 0 \text{ in } B \text{ free gives } Gr = (S_n - S_o)a; \quad (4)$$

whence we readily find

$$G = \frac{a}{r} \cdot \frac{r_1}{a_1} R.$$

Evidently R and G are inversely proportional to their velocities v_1 and v ; see (2). This ought to be true, since in Fig. 186 G is the only working-force, R the only resistance, and the motions are uniform; hence (from eq. (XVI.), § 142)

$$Gv - Rv_1 = 0.$$

$\Sigma X = 0$, for B and truck free, gives

$$G_o = S_n + S_o, \quad \dots \dots \dots (5)$$

while, for impending slip,

$$S_n = S_o e^{f\pi}. \quad \dots \dots \dots (6)$$

By elimination between (4), (5), and (6), we obtain

$$G_s = G_a^r \cdot \frac{e^{f\pi} + 1}{e^{f\pi} - 1} = \frac{L}{v'} \cdot \frac{e^{f\pi} + 1}{e^{f\pi} - 1}, \dots (7)$$

and
$$S_n = \frac{L}{v'} \cdot \frac{e^{f\pi}}{e^{f\pi} - 1} \dots (8)$$

Hence G_s and S_n vary directly as the power transmitted and inversely as the velocity of the belt. For safety G_s should be made $>$ the above value in (7); corresponding values of the two tensions may then be found from (5), and from the relation (see § 150)

$$(S_n - S_o)v' = L. \dots (6a)$$

These *new* values of the tensions will be found to satisfy the condition of no slip, viz.,

$$(S_n : S_o) < e^{f\pi} (\text{§ 170}).$$

For leather on iron, $e^{f\pi} = 2.2$ (see example in § 170), as a low value. The belt should be made strong enough to withstand S_n safely.

As the belt is more tightly stretched, and hence elongated, on the driving than on the following side, it "*creeps*" backward on the driving and forward on the driven pulley, so that the former moves slightly faster than the latter. The loss of work due to this cause does not exceed 2 per cent with ordinary belting (Cotterill).

In the foregoing it is evident that the sum of the tensions in the two sides = G_s , i.e., is the same, whether the power is being transmitted or not; and this is found to be true, both in theory and by experiment, when a tension-weight is not used, viz., when an initial tension S is produced in the whole belt before transmitting the power, then after turning on the latter the sum of the two tensions (driving and following) always = $2S$, since one side elongates as much as the other contracts; it being understood that the pulley-axes preserve a constant distance apart.

172. Rolling Friction.—The few experiments which have been made to determine the resistance offered by a level road-

way to the uniform motion of a roller or wheel rolling upon it corroborate approximately the following theory. The word friction is hardly appropriate in this connection (except when the roadway is perfectly elastic, as will be seen), but is sanctioned by usage.

First, let the roadway or track be compressible, but *inelastic*, G the weight of the roller and its load, and P the horizontal force necessary to preserve a uniform motion (both of translation and rotation). The track (or roller itself) being compressed just in front, and not reacting symmetrically from behind, its resultant pressure against the roller is not at O vertically under the centre, but some small distance, $OD = b$, in front. (The successive crushing of small projecting particles has the same effect.) Since for this case of motion the forces have the same relations as if balanced (see § 124), we may put Σ moms. about $D = 0$,

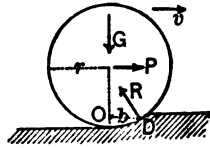

FIG. 188.

$$\therefore Pr = Gb; \text{ or, } P = \frac{b}{r}G. \dots (1)$$

Coulomb found for

Rollers of lignum-vitæ on an oak track, $b = 0.0189$ inches;

Rollers of elm on an oak track, $b = 0.0320$ inches.

Weisbach's experiments give, for cast-iron wheels 20 inches in diameter on cast-iron rails,

$$b = 0.0183 \text{ inches;}$$

and Rittinger, for the same, $b = 0.0193$ inches.

Pambour gives, for iron railroad wheels 39.4 inches in diameter,

$$b = 0.0196 \text{ to } 0.0216 \text{ inches.}$$

According to the foregoing theory, P , the "rolling friction" (see eq. (1)), is directly proportional to G , and inversely to the radius, if b is constant. The experiments of General Morin and others confirm this, while those of Dupuit, Poirée, and Sauvage indicate it to be proportional directly to G , and inversely to the square root of the radius.

Although b is a *distance* to be expressed in linear units, and not an abstract number like the f and f' for sliding and axle-friction, it is sometimes called a "coefficient of rolling friction." In eq. (1), b and r should be expressed in the same unit.

Of course if P is applied at the top of the roller its lever-arm about D is $2r$ instead of r , with a corresponding change in eq. (1).

With ordinary railroad cars the resistance due to axle and rolling frictions combined is about 8 lbs. per ton of weight on a level track. For wagons on macadamized roads $b = \frac{1}{8}$ inch, but on soft ground from 2 to 3 inches.

Secondly, when the roadway is *perfectly elastic*. This is chiefly of theoretic interest, since at first sight no force would be considered necessary to maintain a uniform rolling motion. But, as the material of the roadway is compressed under the roller its surface is first elongated and then recovers its former state; hence some rubbing and consequent sliding friction must

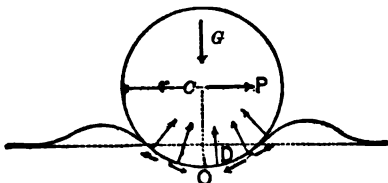

FIG. 189.

occur. Fig. 189 gives an exaggerated view of the circumstances, P being the horizontal force applied at the centre necessary to maintain a uniform motion. The roadway (rubber for instance) is heaped up both in front and behind the roller, O being the point of greatest pressure and elongation of the surface. The forces acting are G , P , the normal pressures, and the frictions due to them, and must form a balanced system. Hence, since G and P , and also the normal pressures, pass through C , the resultant of the frictions must also pass through C ; therefore the frictions, or tangential actions, on the roller must be some forward and some backward

(and not all in one direction, as seems to be asserted on p. 260 of Cotterill's Applied Mechanics, where Professor Reynolds' explanation is cited). The resultant action of the roadway upon the roller acts, then, through some point D , a distance $OD = b$ ahead of O , and in the direction DC , and we have as before, with D as a centre of moments,

$$Pr = Gb, \quad \text{or} \quad P = \frac{b}{r} G.$$

If rolling friction is encountered *above as well as below* the rollers, Fig. 190, the student may easily prove, by considering three separate free bodies, that for uniform motion

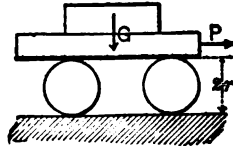

FIG. 190.

$$P = \frac{b + b_1}{2r} G, \quad \dots \dots \dots (2)$$

where b and b_1 are the respective "coefficients of rolling friction" for the upper and lower contacts.

Example 1.—If it is found that a train of cars will move *uniformly* down an incline of 1 in 200, gravity being the only working force, and friction (both rolling and axle) the only resistance, required the coefficient, f' , of axle-friction, the diameter of all the wheels being $2r = 30$ inches, that of the journals $2a = 3$ inches, taking $b = 0.02$ inch for the rolling friction. Let us use equation (XVI.) (§ 142), noting that while the train moves a distance s measured on the incline, its weight G does the work $G \frac{1}{200} s$, the rolling friction $\frac{b}{r} G$ (at* the axles) has been overcome through the distance s , and the axle-friction (total) through the (relative) distance $\frac{a}{r} s$ in the journal boxes; whence, the change in kinetic energy being zero,

$$\frac{1}{200} Gs - \frac{b}{r} Gs - \frac{a}{r} f' Gs = 0.$$

Gs cancels out, the ratios $b : r$ and $a : r$ are $= \frac{b}{r}$ and $\frac{a}{r}$, respectively (being ratios or abstract numbers they have the

* That is, the ideal resistance, at centre of axles and \parallel to the incline, equivalent to actual rolling resistance.

same numerical values, whether the inch or foot is used), and solving, we have

$$f' = 0.05 - 0.0133 = 0.036.$$

Example 2.—How many pounds of tractive effort per ton of load would the train in Example 1 require for uniform motion on a level track? *Ans.* 10 lbs.

173. Railroad Brakes.—During the uniform motion of a railroad car the tangential action between the track and each wheel is small. Thus, in Example 1, just cited, if ten cars of eight wheels each make up the train, each car weighing 20 tons, the backward tangential action of the rails upon each wheel is only 25 lbs. When the brakes are applied to stop the train this action is much increased, and is the only agency by which the rails can retard the train, directly or indirectly: *directly*, when the pressure of the brakes is so great as to prevent the wheels from turning, thereby causing them to “skid” (i.e., slide) on the rails; *indirectly*, when the brake-pressure is of such a value as still to permit perfect rolling of the wheel, in which case the rubbing (and heating) occurs between the brake and wheel, and the tangential action of the rail has a value equal to or less than the friction of rest. In the first case, then (skidding), the retarding influence of the rails is the *friction of motion* between rail and wheel; in the second, a force which may be made as great as the *friction of rest* between rail and wheel. Hence, aside from the fact that skidding produces objectionable flat places on the wheel-tread, the brakes are more effective if so applied that skidding is *impending*, but not actually produced; for the friction of rest is usually greater than that of actual slipping (§ 160). This has been proved experimentally in England. The retarding effect of axle and rolling friction has been neglected in the above theory.

Example 1.—A twenty-ton car with an initial velocity of 80 feet per second (nearly a mile a minute) is to be stopped on a level within 1000 feet; required the necessary friction on each of the eight wheels.

Supposing the wheels not to skid, the friction will occur

between the brakes and wheels, and is overcome through the (relative) distance 1000 feet. Eq. (XVI.), § 142, gives (foot-lb.-second system)

$$0 - 8F \times 1000 = 0 - \frac{1}{2} \frac{40000}{32.2} (80)^2,$$

from which F (= friction at circumference of each wheel) = 496 lbs.

Example 2.—Suppose skidding to be impending in the foregoing, and the coefficient of friction of rest (i.e., impending slipping) between rail and wheel to be $f = 0.20$. In what distance will the car be stopped? *Ans.* 496 ft.

Example 3.—Suppose the car in Example 1 to be on an up-grade of 60 feet to the mile. (In applying eq. (XVI.) here, the weight 20 tons will enter as a resistance.) *Ans.* 439 lbs.

Example 4.—In Example 3, consider all four resistances, viz., gravity, rolling friction, and brake and axle frictions, the distance being 1000 ft., and F the unknown quantity.

(Take the wheel dimensions of p. 189.) *Ans.* 414 lbs.

174. Estimation of Engine and Machinery Friction.—According to Professor Cotterill, a convenient way of estimating the work lost in friction in a steam-engine and machinery driven by it is the following :

Let p_m = mean effective steam-pressure per unit of area of piston, and conceive this composed of three portions, viz.,

p_0 = the necessary pressure to drive the engine alone unloaded, at the proper speed ;

p'_m = pressure necessary to overcome the resistance caused by the useful work of the machines ;

$e p'_m$ = pressure necessary to overcome the friction of the machinery, and that of the engine over and above* its friction when unloaded. This is about 15% of p'_m (i.e., $e = 0.15$), except in large engines, and then rather less.

That is, by formula, F being the piston-area and l the length of stroke, the work per stroke is thus distributed :

$$F p_m l = F [(1 + e) p'_m + p_0] l,$$

* Recent experiments (1888) by Prof. Thurston show that this surplus engine-friction is practically zero.

p , is "from 1 to $1\frac{1}{4}$, or in marine engines 2 lbs. or more per square inch."

175. Anomalies in Friction.—Experiment has shown considerable deviation under certain circumstances from the laws of friction, as stated in § 157 for sliding friction. At pressures below $\frac{1}{4}$ lb. per sq. inch the coefficient f increases when the pressure decreases, while above 500 lbs. (Rennie, with iron and steel) it increases with the pressure. With high velocities, however, above 10 ft. per second, f is much smaller as the velocity increases (Bochet, 1858).

As for axle-friction, experiments instituted by the Society of Mechanical Engineers in England (see the London *Engineer* for March 7 and 21, 1884) gave values for f less than $\frac{1}{100}$ when a "bath" of the lubricant was employed. These values diminished with increase of pressure, and increased with the velocity (see below, Hirn's statement).

Professor Cotterill says, "It cannot be doubted that for values of pv (see § 166) > 5000 the coefficient of friction of well-lubricated bearings of good construction diminishes with the pressure, and may be much less than the value at low speeds as determined by Morin" (p. 259 of his *Applied Mechanics*).

Professor Thurston's experiments confirmed those of Hirn as to the following relation: "The friction of lubricated surfaces is nearly proportional to the square root of the area and pressure." Hirn also maintained that, "in ordinary machinery, friction varies as the square root of the velocity."

176. Rigidity of Ropes.—If a rope or wire cable passes over a pulley or sheave, a force P is required on one side greater than the resistance Q on the other for uniform motion, aside from axle-friction. Since in a given time both P and Q describe the same space s , if P is $> Q$, then Ps is $> Qs$, i.e., the work done by P is $>$ than that expended upon Q . This is because some of the work Ps has been expended in bending the stiff rope or cable, and in overcoming friction between the strands, both where the rope passes upon and where it leaves

the pulley. With hemp ropes, Fig. 191, the material being nearly inelastic, the energy spent in bending it on at D is nearly all lost, and energy must also be spent in straightening

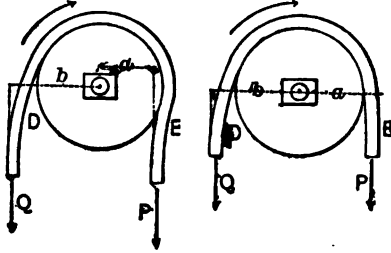

FIG. 191.

it at E ; but with a wire rope or cable some of this energy is restored by the elasticity of the material. The energy spent in friction or rubbing of strands, however, is lost in both cases.

The figure shows geometrically why P must be $> Q$ for a uniform motion, for the lever-arm, a , of P is evidently $< b$ that of Q . If axle-friction is also considered, we must have

$$Pa = Qb + f'(P + Q)r,$$

r being the radius of the journal.

Experiments with cordage have been made by Prony, Coulomb, Eytelwein, and Weisbach, with considerable variation in the results and formulæ proposed. (See Coxe's translation of vol. i., Weisbach's Mechanics.)

With pulleys of large diameter the effect of rigidity is very slight. For instance, Weisbach gives an example of a pulley five feet in diameter, with which, Q being = 1200 lbs., P = 1219. A wire rope $\frac{3}{4}$ in. in diameter was used. Of this difference, 19 lbs., only 5 lbs. was due to rigidity, the remainder, 14 lbs., being caused by axle-friction. When a hemp-rope 1.6 inches in diameter was substituted for the wire one, $P - Q = 27$ lbs., of which 12 lbs. was due to the rigidity. Hence in one case the loss of work was less than $\frac{1}{3}$ of 1%, in the other about 1%, caused by the rigidity. For very small sheaves and thick ropes the loss is probably much greater.

177. Miscellaneous Examples.—*Example 1.* The end of a shaft 12 inches in diameter and making 50 revolutions per minute exerts against its bearing an axial pressure of 10 tons and a lateral pressure of 40 tons. With $f = f' = 0.05$, required the H. P. lost in friction. *Ans.* 22.2 H. P.

Example 2.—A leather belt passes over a vertical pulley, covering half its circumference. One end is held by a spring balance, which reads 10 lbs. while the other end sustains a weight of 20 lbs., the pulley making 100 revolutions per minute. Required the coefficient of friction, and the H. P. spent in overcoming the friction. Also suppose the pulley turned in the other direction, the weight remaining the same. The diameter of the pulley is 18 inches. *Ans.* $\left\{ \begin{array}{l} f = 0.22; \\ 0.142 \text{ and } .284 \text{ H. P.} \end{array} \right.$

Example 3.—A grindstone with a radius of gyration = 12 inches has been revolving at 120 revolutions per minute, and at a given instant is left to the influence of gravity and axle friction. The axles are $1\frac{1}{2}$ inches in diameter, and the wheel makes 160 revolutions in coming to rest. Required the coefficient of axle-friction. *Ans.* $f = 0.389$.

Example 4.—A board A , weight 2 lbs., rests horizontally on another B ; coefficient of friction of rest between them being $f = 0.30$. B is now moved horizontally with a uniformly accelerated motion, the acceleration being = 15 feet per "square second;" will A keep company with it, or not? *Ans.* "No."

PART III.

STRENGTH OF MATERIALS.

[OR MECHANICS OF MATERIALS].

CHAPTER I.

ELEMENTARY STRESSES AND STRAINS.

178. **Deformation of Solid Bodies.**—In the preceding portions of this work, what was called technically a “rigid body,” was supposed incapable of changing its form, i.e., the positions of its particles relatively to each other, under the action of any forces to be brought upon it. This supposition was made because the change of form which must actually occur does not appreciably alter the distances, angles, etc., measured in any one body, among most of the pieces of a properly designed structure or machine. To show how the individual pieces of such constructions should be designed to avoid undesirable deformation or injury is the object of this division of Mechanics of Engineering, viz., the Strength of Materials.

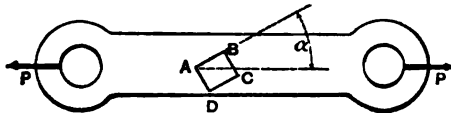

FIG. 192. § 178.

As perhaps the simplest instance of the deformation or distortion of a solid, let us consider the case of a prismatic rod in a state of tension, Fig. 192 (link of a surveyor's

chain, e.g.). The pull at each end is P , and the body is said to be under a tension of P (lbs., tons, or other unit), not $2P$. Let $ABCD$ be the end view of an elementary paralleliped, originally of square section and with faces at 45° with the axis of the prism. It is now deformed, the four faces perpendicular to the paper being longer* than before, while the angles BAD and BOD , originally right angles, are now smaller by a certain amount δ , ABC and ADC larger by an equal amount δ . The element is said to be in a state of strain, viz.: the elongation of its edges (parallel to paper) is called a *tensile strain*, while the alteration in the angles between its faces is called a *shearing strain*, or angular distortion (sometimes also called a sliding, or tangential, strain, since BC has been made to slide, relatively to AD , and thereby caused the change of angle). [This use of the word strain, to signify change of form and not the force producing it, is of recent adoption among many, though not all, technical writers.]

179. Strains. Two Kinds Only.—Just as a curved line may be considered to be made up of small straight-line elements, so the substance of any solid body may be considered to be made up of small contiguous parallelipedes, whose angles are each 90° before the body is subjected to the action of forces, but which are not necessarily cubes. A line of such elements forming an elementary prism is sometimes called a *fibre*, but this does not necessarily imply a fibrous nature in the material in question. The system of imaginary cutting surfaces by which the body is thus subdivided need not consist entirely of planes; in the subject of Torsion, for instance, the parallelipedical elements considered lie in concentric cylindrical shells, cut both by transverse and radial planes.

Since these elements are taken so small that the only possible changes of form in any one of them, as induced by a system of external forces acting on the body, are

* When α is nearly 0° (or 90°) BC and AD (or AB and DC) are shorter than before, on account of lateral contraction; see § 198.

elongations or contractions of its edges, and alteration of its angles, there are but two kinds of strain, elongation (contraction, if negative) and shearing.

180. Distributed Forces or Stresses.—In the matter preceding this chapter it has sufficed for practical purposes to consider a force as applied at a *point* of a body, but in reality it must be distributed over a definite area; for otherwise the material would be subjected to an infinite force per unit of area. (Forces like gravity, magnetic attraction, etc., we have already treated as distributed over the mass of a body, but reference is now had particularly to the pressure of one body against another, or the action of one portion of the body on the remainder.) For instance, sufficient surface must be provided between the end of a loaded beam and the pier on which it rests to avoid injury to either. Again, too small a wire must not be used to sustain a given load, or the tension per unit of area of its cross section becomes sufficient to rupture it.

Stress is distributed force, and its intensity at any point of the area is

$$p = \frac{dP}{dF} \quad \cdot \quad \cdot \quad \cdot \quad \cdot \quad (1)$$

where dF is a small area containing the point and dP the force coming upon that area. If equal dP 's (all parallel) act on equal dF 's of a plane surface, the stress is said to be of uniform intensity, which is then

$$p = \frac{P}{F} \quad \cdot \quad \cdot \quad \cdot \quad \cdot \quad (2)$$

where P = total force and F the total area over which it acts. The steam pressure on a piston is an example of stress of uniform intensity.

For example, if a force $P=28800$ lbs, is uniformly distributed over a plane area of $F=72$ sq. inches, or $\frac{1}{2}$ of a sq. foot, the intensity of the stress is

$$p = \frac{28800}{72} = 400 \text{ lbs. per sq. inch,}$$

(or $p = 28800 \div \frac{1}{2} = 57600$ lbs. per sq. foot, or $p = 14.400 \div \frac{1}{2} = 28.8$ tons per sq. ft., etc.).

181. Stresses on an Element; of Two Kinds Only.—When a solid body of any material is in equilibrium under a system of forces which do not rupture it, not only is its shape altered (i.e. its elements are *strained*), and stresses produced on those planes on which the forces act, but other stresses also are induced on some or all internal surfaces which separate element from element, (over and above the forces with which the elements may have acted on each other before the application of the external stresses or “applied forces”). So long as the whole solid is the “*free body*” under consideration, these internal stresses, being the forces with which the portion on one side of an imaginary cutting plane acts on the portion on the other side, do not appear in any equation of equilibrium (for if introduced they would cancel out); but if we consider free a portion only, some or all of whose bounding surfaces are cutting planes of the original body, the stresses existing on these planes are brought into the equations of equilibrium.

Similarly, if a single element of the body is treated by itself, the stresses on all six of its faces, together with its weight, form a balanced system of forces, the body being supposed at rest.

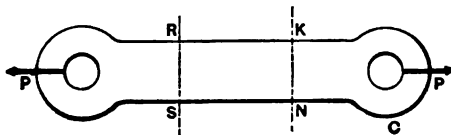

FIG. 183.

As an example of internal stress, consider again the case of a rod in tension ; Fig. 193 shows the whole rod (or eye-bar) free, the forces P being the pressures of the pins in the eyes, and causing external stress (compression here) on the surfaces of contact. Conceive a right section made through RS , far enough from the eye, O , that we may consider the internal stress to be uniform in this section, and consider the portion RSO as a free body, in Fig. 194. The stresses on RS , now one of the bounding surfaces of the free body, must be parallel to P , i.e., normal to RS ; (otherwise they would have components perpendicular to P , which is precluded by the necessity of $\Sigma Y = 0$, and the supposition of uniformity.) Let F = the sec-

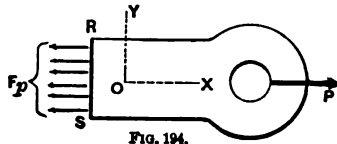

FIG. 194.

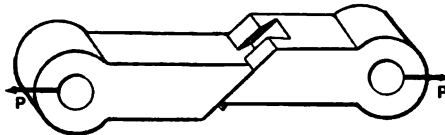

FIG. 195.

tional area RS , and p = the stress per unit of area ; then

$$\Sigma X=0 \text{ gives } P=Fp, \text{ i.e., } p=\frac{P}{F} \quad . \quad .(2)$$

The state of internal stress, then, is such that on planes perpendicular to the axis of the bar the stress is *tensile* and *normal* (to those planes). Since if a section were made oblique to the axis of the bar, the stress would still be parallel to the axis for reasons as above, it is evident that on an oblique section, the stress has components both *normal* and *tangential* to the section, the normal component being a tension.

The presence of the *tangential*, or *shearing* stress in oblique sections is rendered evident by considering that if an oblique dove-tail joint were cut in the rod, Fig. 195, the shearing stress on its surfaces may be sufficient to overcome friction and cause sliding along the oblique plane.

If a short prismatic block is under the compressive action of two forces, each $= P$ and applied centrally in one base, we may show that the state of internal stress is the same as that of the rod under tension, except that the normal stresses are of contrary sign, i.e., compressive instead of tensile, and that the shearing stresses (or tendency to slide) on oblique planes are opposite in direction to those in the rod.

Since the resultant stress on a given internal plane of a body is fully represented by its normal and tangential components, we are therefore justified in considering but two kinds of internal stress, *normal* or *direct*, and *tangential* or *shearing*.

182. Stress on Oblique Section of Rod in Tension.—Consider

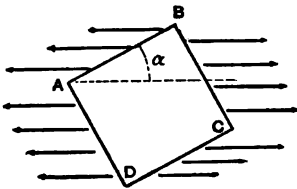

FIG. 196.

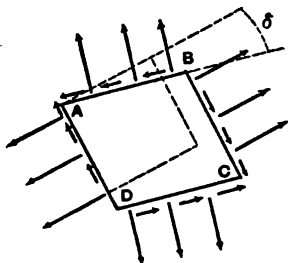

FIG. 197.

free a small cubic element whose edge $= a$ in length; it has two faces parallel to the paper, being taken near the middle of the rod in Fig. 192. Let the angle which the face AB , Fig. 196, makes with the axis of the rod be $= \alpha$. This angle, for our present purpose, is considered to remain the same while the two forces P are acting, as before their action. The resultant stress on the face AB having an intensity $p = P \div F$, (see eq. 2) per unit of *transverse section* of rod, is $= p (a \sin \alpha) a$. Hence its component normal to AB is

$pa^2 \sin^2 \alpha$; and the tangential or shearing component along

$AB = pa^2 \sin a \cos a$. Dividing by the area, a^2 , we have the following:

For a rod in simple tension we have, on a plane making an angle, a , with the axis:

a Normal Stress $= p \sin^2 a$ per unit of area . . . (1)

and a Shearing Stress $= p \sin a \cos a$ per unit of area . . . (2)

"Unit of area" here refers to the oblique plane in question, while p denotes the normal stress per unit of area of a transverse section, i.e., when $a=90^\circ$, Fig. 194.

The stresses on CD are the same in value as on AB , while for BC and AD we substitute $90^\circ - a$ for a . Fig. 197 shows these normal and shearing stresses, and also, much exaggerated, the strains or change of form of the element (see Fig. 192).

182a. Relation between Stress and Strain.—Experiment shows that so long as the stresses are of such moderate value that the piece recovers its original form completely when the external forces which induce the stresses are removed, the following is true and is known as *Hooke's Law* (stress proportional to strain). As the forces P in Fig. 193 (rod in tension) are gradually increased, the elongation, or additional length, of RK increases in the same ratio as the normal stress, p , on the sections RS and KN , per unit of area [§ 191].

As for the distorting effect of shearing stresses, consider in Fig. 197 that since

$$p \sin a \cos a = p \cos (90^\circ - a) \sin (90^\circ - a)$$

the shearing stress per unit of area is of equal value on all four of the faces (perpendicular to paper) in the elementary block, and is evidently accountable for the shearing strain, i.e., for the angular distortion, or difference, δ , between 90° and the present value of each of the four angles. According to Hooke's Law then, as P increases within the limit mentioned above, δ varies proportionally to

$$p \sin a \cos a, \text{ i.e. to the stress.}$$

182b. **Example.**—Supposing the rod in question were of a kind of wood in which a shearing stress of 200 lbs. per sq. inch along the grain, or a normal stress of 400 lbs. per sq. inch, perpendicular to a fibre-plane will produce rupture, required the value of a the angle which the grain must make with the axis that, as P increases, the danger of rupture from each source may be the same. This requires that $200:400::p \sin a \cos a:p \sin^2 a$, i.e. $\tan. a$ must $=2.000$. $\therefore a=63\frac{1}{2}^\circ$. If the cross section of the rod is 2 sq. inches, the force P at each end necessary to produce rupture of either kind, when $a=63\frac{1}{2}^\circ$, is found by putting $p \sin a \cos a=200$. $\therefore p=500.0$ lbs. per sq. inch. Whence, since $p=P \div F$, $P=1000$ lbs. (Units, inch and pound.)

183. **Elasticity** is the name given to the property which most materials have, to a certain extent, of regaining their original form when the external forces are removed. If the state of stress exceeds a certain stage, called the **Elastic Limit**, the recovery of original form on the part of the elements is only partial, the permanent deformation being called the **Set**.

Although theoretically the elastic limit is a perfectly definite stage of stress, experimentally it is somewhat indefinite, and is generally considered to be reached when the permanent set becomes well marked as the stresses are increased and the test piece is given ample time for recovery in the intervals of rest.

The **Safe Limit** of stress, taken well within the elastic limit, determines the *working strength* or safe load of the piece under consideration. E.g., the tables of safe loads of the rolled wrought iron beams, for floors, of the New Jersey Steel and Iron Co., at Trenton, are computed on the theory that the greatest normal stress (tension or compression) occurring on any internal plane shall not exceed 12,000 lbs. per sq. inch; nor the greatest shearing stress 4,000 lbs. per sq. inch.

The Ultimate Limit is reached when rupture occurs.

184. The Modulus of Elasticity (sometimes called co-efficient of elasticity) is the number obtained by dividing the stress per unit of area by the corresponding relative strain.

Thus, a rod of wrought iron $\frac{1}{2}$ sq. inch sectional area being subjected to a tension of $2\frac{1}{2}$ tons—5,000 lbs., it is found that a length which was six feet before tension is = 6.002 ft. during tension. The relative longitudinal strain or elongation is then— $(0.002) \div 6 = 1 : 3,000$ and the corresponding stress (being the normal stress on a transverse plane) has an intensity of

$$p_t = P \div F = 5,000 \div \frac{1}{2} = 10,000 \text{ lbs., per sq. inch.}$$

Hence by definition the modulus of elasticity is (for tension)

$$E_t = p_t \div \epsilon = 10,000 \div \frac{1}{3,000} = 30,000,000 \text{ lbs. per sq. inch, (the}$$

sub-script "t" refers to tension).

It will be noticed that since ϵ is an abstract number, E_t is of the same quality as p_t , i.e., lbs. per sq. inch, or one dimension of force divided by two dimensions of length. (In the subject of strength of materials the inch is the most convenient English linear unit, when the pound is the unit of force; sometimes the foot and ton are used together.)

The foregoing would be called *the modulus of elasticity of wrought iron in tension* in the direction of the fibre, as given by the experiment quoted. But by Hooke's Law p and ϵ vary together, for a given direction in a given material, hence *within the elastic limit E is constant* for a given direction in a given material. Experiment confirms this approximately.

Similarly, the modulus of elasticity for *compression E*,

in a given direction in a given material may be determined by experiments on short blocks, or on rods confined laterally to prevent flexure.

As to the modulus of elasticity for shearing, E_s , we divide the shearing stress per unit of area in the given direction by δ (in π measure) the corresponding angular strain or distortion; e.g., for an angular distortion of 1° or $\delta = .0174$, and a shearing stress of 1,566 lbs. per sq. inch, we have $E_s = \frac{1,566}{.0174} = 9,000,000$ lbs. per sq. inch.

Unless otherwise specified, by modulus of elasticity will be meant a value derived from experiments conducted within the elastic limit, and this, whether for normal stress or for shearing, is approximately constant for a given direction in a given substance.*

185. Isotropes.—This name is given to materials which are homogenous as regards their elastic properties. In such a material the moduli of elasticity are individually the same for all directions. E.g., a rod of rubber cut out of a large mass will exhibit the same elastic behavior when subjected to tension, whatever its original position in the mass. Fibrous materials like wood and wrought iron are not isotropic; the direction of grain in the former must always be considered. The "piling" and welding of numerous small pieces of iron prevent the resultant forging from being isotropic.

186. Resilience refers to the potential energy stored in a body held under external forces in a state of stress which does not pass the elastic limit. On its release from constraint, by virtue of its elasticity it can perform a certain amount of work called the resilience, depending in amount upon the circumstances of each case and the nature of the material. See § 148.

187. General Properties of Materials.—In view of some definitions already made we may say that a material is *ductile*

* The moduli, or "co-efficients," of elasticity as used by physicists are well explained in Stewart and Gee's *Practical Physics*, Vol. I., pp. 164, etc. Their "co-efficient of rigidity" is our E_s .

when the ultimate limit is far removed from the elastic limit; that it is *brittle* like glass and cast iron, when those limits are near together. A small modulus of elasticity means that a comparatively small force is necessary to produce a given change of form, and vice versâ, but implies little or nothing concerning the stress or strain at the elastic limit; thus Weisbach gives E_c , lbs. per sq. inch for wrought iron = 28,000,000— double the E_c for cast iron while the compressive stresses at the elastic limit are the same for both materials (nearly).

188. General Problem of Internal Stress.—This, as treated in the mathematical Theory of Elasticity, developed by Lamé, Clapeyron and Poisson, may be stated as follows:

Given the original form of a body when free from stress, and certain co-efficients depending on its elastic properties; *required the new position, the altered shape, and the intensity of the stress on each of the six faces, of every element of the body, when a given balanced system of forces is applied to the body.*

Solutions, by this theory, of certain problems of the nature just given involve elaborate, intricate, and bulky analysis; but for practical purposes Navier's theories (1838) and others of more recent date, are sufficiently exact, when their moduli are properly determined by experiments covering a wide range of cases and materials. These will be given in the present work, and are comparatively simple. In some cases graphic will be preferred to analytic methods as more simple and direct, and indeed for some problems they are the only methods yet discovered for obtaining solutions. Again, experiment is relied on almost exclusively in dealing with bodies of certain forms under peculiar systems of forces, empirical formulæ being based on the experiments made; e.g., the collapsing of boiler flues, and in some degree the flexure of long columns.

189. Classification of Cases.—Although in almost any case whatever of the deformation of a solid body by a balanced system of forces acting on it, normal and shearing stresses are both developed in every element which is affected at all (according to the plane section considered,) still, cases where the body is prismatic, and the external system consists of two equal and opposite forces, one at each end of the piece and directed away from each other, are commonly called **cases of Tension**; (Fig. 192); if the piece is a short prism with the same two terminal forces directed *toward* each other, the case is said to be one of **Compression**; a case similar to the last, but where the prism is quite long (“long column”), is a case of **Flexure** or bending, as are also most cases where the “applied forces” (i.e., the external forces), are not directed along the axis of the piece. Riveted joints and “pin-connections” present cases of **Shearing**; a twisted shaft one of **Torsion**. When the gravity forces due to the weights of the elements are also considered, a combination of two or more of the foregoing general cases may occur.

In each case, as treated, the principal objects aimed at are, so to design the piece or its loading that the greatest stress, in whatever element it may occur, shall not exceed a safe value; and sometimes, furthermore, to prevent too great deformation on the part of the piece. The first object is to provide sufficient **strength**; the second sufficient **stiffness**.

190. Temperature Stresses.—If a piece is under such constraint that it is not free to change its form with changes of temperature, external forces are induced, the stresses produced by which are called *temperature stresses*.

TENSION.

191. **Hooke's Law by Experiment.**—As a typical experiment in the tension of a long rod of ductile metal such as wrought iron and the mild steels, the following table is quoted from Prof. Cotterill's "Applied Mechanics." The experiment is old, made by Hodgkinson for an English Railway Commission, but well adapted to the purpose. From the great length of the rod, which was of wrought iron and 0.517 in. in diameter, the portion whose elongation was observed being 49 ft. 2 in. long, the small increase in length below the elastic limit was readily measured. The successive loads were of such a value that the tensile stress $p = P \div F$, or normal stress per sq. in. in the transverse section, was made to increase by equal increments of 2657.5 lbs. per sq. in., its initial value. After each application of load the elongation was measured, and after the removal of the load, the permanent set, if any.

Table of elongations of a wrought iron rod, of a length—49 ft. 2 in.

p	λ	$\Delta\lambda$	$\epsilon = \lambda \div l$	λ'
Load, (lbs. per square inch.)	Elongation, (inches.)	Increment of Elongation.	ϵ , the relative elongation, (abstract number.)	Permanent Set, (inches.)
1x2657.5	.0485	.0485	0.000082	
2x "	.1086	.061	.000186	
3x "	.1675	.066	.000283	0.0015
4x "	.224	.0665	.000379	.002
5x "	.2805	.0665	.000475	.0027
6x "	.337	.0665	.000570	.003
7x "	.393	.066		.004
8x "	.452	.069	.000766	.0075
9x "	.5155	.0685		.0125
10x "	.586	.0625		.049
11x "	.760	.162		.1545
12x "	1.210	.550		.667
etc.				

Referring now to Fig. 198, the notation is evident. P is the total load in any experiment, F the cross section of the rod; hence the normal stress on the transverse section is $p = P \div F$. When the loads are increased by equal increments, the corresponding increments of the elongation λ should also be equal if Hooke's law is true. It will be noticed in the table that this is very nearly true up to the 8th loading, i.e., that $\Delta\lambda$, the difference between two consecutive values of λ , is nearly constant. In other words the proposition holds good:

$$P : P_1 :: \lambda : \lambda_1$$

if P and P_1 are any two loads below the 8th, and λ and λ_1 the corresponding elongations.

The permanent set is just perceptible at the 3d load, and increases rapidly after the 8th, as also the increment of elongation. Hence at the 8th load, which produces a tensile stress on the cross section of $p = 8 \times 2667.5 = 21340.0$ lbs. per sq. inch, the *elastic limit* is reached.

As to the state of stress of the individual elements, if

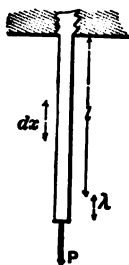

Fig. 198

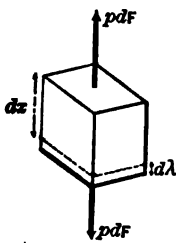

Fig. 199.

we conceive such sub-division of the rod that four edges of each element are parallel to the axis of the rod, we find that it is in equilibrium between two normal stresses on its end faces (Fig. 199) of a value $= pdF = (P \div F)dF$ where dF is the horizontal section of the element.

If dx was the original length,

and $d\lambda$ the elongation produced by pdF , we shall have, since all the dx 's of the length are equally elongated at the same time,

$$\frac{d\lambda}{dx} = \frac{\lambda}{l}$$

where l = total (original) length. But $d\lambda \div dx$ is the relative elongation ϵ , and by definition (§ 184) the *Modulus of Elasticity for Tension*, $E_t = p \div \epsilon$

$$\therefore E_t = \frac{p}{\frac{d\lambda}{dx}}; \text{ or } E_t = \frac{Pl}{F\lambda} \quad \dots \quad (1)$$

Eq. (1) enables us to solve problems involving the elongation of a prism under tension, so long as the elastic limit is not surpassed.

The values of E_t computed from experiments like those just cited should be the same for any load under the elastic limit, if Hooke's law were accurately obeyed, but in reality they differ somewhat, especially if the material lacks homogeneity. In the present instance (see Table) we have from the

2d Exper.	$E_t = p \div \epsilon = 28,680,000$	lbs. per sq. in.
5th "	$E_t = \text{ " } = 28,009,000$	" "
8th "	$E_t = \text{ " } = 27,848,000$	" "

If similar computations were made beyond the elastic limit, i.e., beyond the 8th Exper., the result would be much smaller, showing the material to be yielding much more readily.

192. Strain Diagrams.—If we plot the stresses per sq. inch (p) as ordinates of a curve, and the corresponding relative elongations (ϵ) as abscissas, we obtain a useful graphic representation of the results of experiment.

Thus, the table of experiments just cited being utilized in this way, we obtain on paper a series of points through which a smooth curve may be drawn, viz.: OBC Fig. 200, for wrought iron. Any convenient scales may be used for p and ϵ ; and experiments having been made on other metals in tension and the results plotted to the *same scales*

as before for p and ϵ , we have the means of comparing their tensile properties. Fig. 200 shows two other curves, representing (roughly) the average behavior of steel and cast iron. At the respective elastic limits B , B' , and B'' , it will be noticed that the curve for wrought iron makes a sudden turn from the vertical, while those of the others curve away more gradually; that the curve for steel lies nearer the vertical axis than the others, which indicates a higher value for E_t ; and that the ordinates BA' , $B'A'$, and $B''A''$ (respectively 21,000, 9,000, and 30,000 lbs. per sq. inch) in-

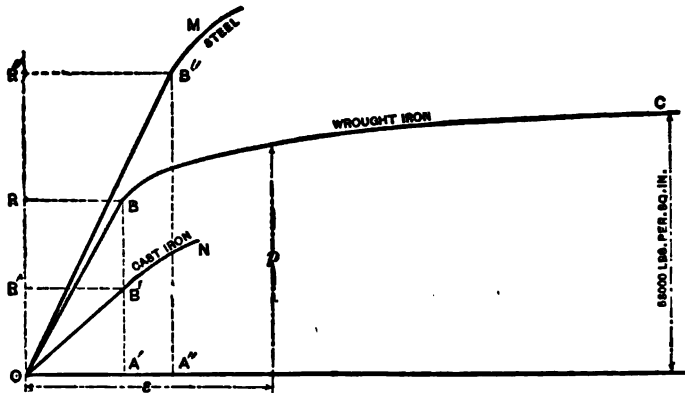

FIG. 200.

dicating the tensile stress at the elastic limit. These latter quantities will be called the *moduli of tenacity at elastic limit* for the respective materials. [On a true scale the point C would be much further to the right than here shown. Only one half of the curve for steel is given, for want of space.]

Within the elastic limit the curves are nearly straight (proving Hooke's law) and if α , α' , and α'' are the angles made by these straight portions with the axis of X (i.e., of ϵ), we shall have

$$(E_t \text{ for w. iron}) : (E_t \text{ c. iron}) : (E_t \text{ steel}) :: \tan \alpha : \tan \alpha' : \tan \alpha''$$

as a graphic relation between their moduli of elasticity (since $E = \frac{P}{\epsilon}$).

Beyond the elastic limit the wrought iron rod shows large increments of elongation for small increments of stress, i.e., the curve becomes nearly parallel to the horizontal axis, until rupture occurs at a stress of 53,000 lbs. per sq. inch of *original sectional area* (at rupture this area is somewhat reduced, especially in the immediate neighborhood of the section of rupture; see next article) and after a relative elongation $\epsilon =$ about 0.30, or 30%. (The preceding table shows only a portion of the results.) The *curve for steel* shows a much higher breaking stress (100,000 lbs. per sq. in.) than the wrought iron, but the total elongation is smaller, $\epsilon =$ about 10%. This is an average curve; tool steels give an elongation at rupture of about 4 to 5%, while soft steels resemble wrought iron in their ductility, giving an extreme elongation of from 10 to 20%. Their breaking stresses range from 70,000 to 150,000 lbs. or more per sq. inch. *Cast iron*, being comparatively brittle, reaches at rupture an elongation of only 3 or 4 *tenths of one per cent.*, the rupturing stress being about 18,000 lbs. per sq. inch. The elastic limit is rather ill defined in the case of this metal; and the proportion of carbon and the mode of manufacture have much influence on its behavior under test.

193. *Lateral Contraction.*—In the stretching of prisms of nearly all kinds of material, accompanying the elongation of length is found also a diminution of width whose relative amount in the case of the three metals just treated is about $\frac{1}{3}$ or $\frac{1}{4}$ of the relative elongation (within elastic limit). Thus, in the third experiment in the table of § 191, this relative lateral contraction or decrease of diameter $= \frac{1}{3}$ to $\frac{1}{4}$ of ϵ , i.e., about 0.00008. In the case of cast iron and hard steels contraction is not noticeable ex-

cept by very delicate measurements, both within and without the elastic limit; but the more ductile metals, as wrought iron and the soft steels, when stretched beyond the elastic limit show this feature of their deformation in a very marked degree. Fig. 201 shows by dotted lines the original contour of a wrought iron rod, while the continuous lines indicate that at rupture. At the cross section of rupture, whose position is determined by some local weakness, the drawing out is peculiarly pronounced.

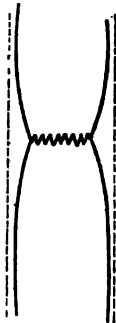

FIG. 201.

The contraction of area thus produced is sometimes as great as 50 or 60% at the fracture.

194. "Flow of Solids."—When the change in relative position of the elements of a solid is extreme, as occurs in the making of lead pipe, drawing of wire, the stretching of a rod of ductile metal as in the preceding article, we have instances of what is called the *Flow of Solids*, interesting experiments on which have been made by Tresca.

195. *Moduli of Tenacity*.—The tensile stress per square inch (of original sectional area) required to rupture a prism of a given material will be denoted by T and called the *modulus of ultimate tenacity*; similarly, the *modulus of safe tenacity*, or greatest safe tensile stress on an element, by T' ; while the tensile stress at elastic limit may be called T'' . The ratio of T' to T'' is not fixed in practice but depends upon circumstances (from $\frac{1}{3}$ to $\frac{2}{3}$).

Hence, if a prism of any material sustains a total pull or load P , and has a sectional area $=F$, we have

$$\left. \begin{aligned} P &= FT \text{ for the ultimate or breaking load.} \\ P' &= FT' \text{ " " safe load.} \\ P'' &= FT'' \text{ " " load at elastic limit.} \end{aligned} \right\} \dots (2)$$

Of course T' should always be less than T'' .

196. Resilience of a Stretched Prism.—Fig. 202. In the gradual stretching of a prism, fixed at one extremity, the value of the tensile force P at the other necessarily depends on the elongation λ at each stage of the lengthening, according to the relation [eq. (1) of § 191.]

$$\lambda = \frac{Pl}{FE} \dots \dots \dots (3)$$

within the elastic limit. (If we place a weight G on the flanges of the unstretched prism and then leave it to the action of gravity and the elastic action of the prism, the weight begins to sink, meeting an increasing pressure P , proportional to λ , from the flanges). Suppose the stretching to continue until P reaches some value P' (at elastic limit say), and λ a value λ'' . Then the work done so far is

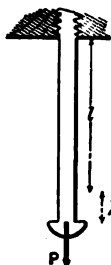

FIG. 202.

$$U = \text{mean force} \times \text{space} = \frac{1}{2} P' \lambda'' \dots (4)$$

But from (2) $P' = FT''$, and (see §§ 184 and 191)

$$\lambda'' = \epsilon'' l$$

$$\therefore (4) \text{ becomes } U = \frac{1}{2} T'' \epsilon'' \cdot Fl = \frac{1}{2} T'' \epsilon'' V \dots (5)$$

where V is the volume of the prism. The quantity $\frac{1}{2} T'' \epsilon''$, or work done in stretching to the elastic limit a cubic inch (or other unit of volume) of the given material, Weisbach calls the *Modulus of Resilience for tension*. From (5) it appears that the amounts of work done in stretching to the elastic limit prisms of the same material but of different dimensions are proportional to *their volumes* simply.

The quantity $\frac{1}{2} T'' \epsilon''$ is graphically represented by the area of one of the triangles such as $OA'B$, $OA''B''$ in Fig. 200; for (in the curve for wrought iron for instance) the modulus of tenacity at elastic limit is represented by $A'B$, and ϵ'' (i.e., ϵ for elastic limit) by OA' . The remainder of

the area OBC included between the curve and the horizontal axis, i.e., from B to C , represents the work done in stretching a cubic unit from the elastic limit to the point of rupture, for each vertical strip having an altitude $-p$ and a width $=d\epsilon$, has an area $-pd\epsilon$, i.e., the work done by the stress p on one face of a cubic unit through the distance $d\epsilon$, or increment of elongation.

If a weight or load $=G$ be "suddenly" applied to stretch the prism, i.e., placed on the flanges, barely touching them, and then allowed to fall, when it comes to rest again it has fallen through a height λ_1 , and experiences at this instant some pressure P_1 from the flanges; $P_1=?$ The work $G\lambda_1$ has been entirely expended in stretching the prism, none in changing the kinetic energy of G , which $=0$ at both beginning and end of the distance λ_1 ,

$$\therefore G\lambda_1 = \frac{1}{2}P_1\lambda_1 \qquad \therefore P_1 = 2G.$$

Since $P_1=2G$, i.e., is $> G$, the weight does not remain in this position but is pulled upward by the elasticity of the prism. In fact, the motion is *harmonic* (see §§ 59 and 138). Theoretically, the elastic limit not being passed, the oscillations should continue indefinitely.

Hence a load G "suddenly applied" occasions *double the tension* it would if compelled to sink gradually by a support underneath, which is not removed until the tension is just $=G$, oscillation being thus prevented.

If the weight G sinks through a height $=h$ before striking the flanges, Fig. 202, we shall have similarly, within elastic limit, if $\lambda_1 =$ greatest elongation, (the mass of rod being small compared with that of G).

$$G(h+\lambda_1) = \frac{1}{2}P_1\lambda_1 \qquad \dots \dots \dots (6)$$

If the elastic limit is to be just reached we have from eqs. (5) and (6), neglecting λ_1 compared with h ,

$$Gh = \frac{1}{2}T''\epsilon''V \qquad \dots \dots \dots (7)$$

an equation of condition that the prism shall not be injured.

Example.—If a steel prism have a sectional area of $\frac{1}{4}$ sq. inch and a length $l=10$ ft. =120 inches, what is the greatest allowable height of fall of a weight of 200 lbs., that the final tensile stress induced may not exceed $T''=30,000$ lbs. per sq. inch, if $\epsilon''=.002$? From (7), using the inch and pound, we have

$$h = \frac{T'' \epsilon'' V}{2G} = \frac{30,000 \times .002 \times \frac{1}{4} \times 120}{2 \times 200} = 4.5 \text{ inches.}$$

197. Stretching of a Prism by Its Own Weight.—In the case

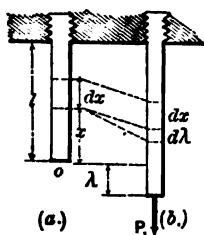

FIG. 203.

of a very long prism such as a mining-pump rod, its weight must be taken into account as well as that of the terminal load P , see Fig. 203. At (a) the prism is shown in its unstrained condition; at (b) strained by the load P_1 and its own weight. Let the cross section be $=F$, the heaviness of the prism $=\gamma$. Then the relative extension of any element at a distance

from o is

$$\epsilon = \frac{d\lambda}{dx} = \frac{(P_1 + \gamma Fx)}{FE_t} \quad (1)$$

(See eq. (1) § 191); since $P_1 + F\gamma x$ is the load hanging upon the cross section at that locality. Equal dx 's, therefore, are unequally elongated, x varying from 0 to l . The total elongation is

$$\lambda = \int_0^l d\lambda = \frac{1}{FE_t} \int_0^l [P_1 dx + \gamma Fx dx] = \frac{P_1 l}{FE_t} + \frac{1}{2} \frac{Gl}{FE_t}$$

I.e., λ = the amount due to P_1 , plus an extension which half the weight of the prism would produce, hung at the lower extremity.

The foregoing relates to the deformation of the piece, and is therefore a problem of *stiffness*. As to the *strength* of the prism, the relative elongation $\epsilon = d\lambda \div dx$ [see eq. (1)], which is variable, must nowhere exceed a safe value $\epsilon' = T' \div E_i$ (from eq. (1) § 191, putting $P = FT'$, and $\lambda = \lambda'$). Now the greatest value of the ratio $d\lambda : dx$, by inspecting eq. (1), is seen to be at the upper end where $x = l$. The proper cross section F , for a given load P_1 , is thus found.

Putting $\frac{P_1 + \gamma F l}{F E_i} = \frac{T'}{E_i}$, we have $F = \frac{P_1}{T' - \gamma l}$. . . (2)

198. Solid of Uniform Strength in Tension, or hanging body of minimum material supporting its own weight and a terminal load P_1 . Let it be a solid of revolution. If every cross-section F at a distance $= x$ from the lower extremity, bears its safe load FT' , every element of the body is doing full duty, and its form is the most economical of material.

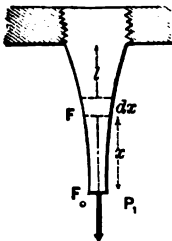

FIG. 204.

The lowest section must have an area $F_0 = P_1 \div T'$, since P_1 is its safe load. Fig.

204. Consider any horizontal lamina; its weight is $\gamma F dx$, ($\gamma =$ heaviness of the material, supposed homogenous), and its lower base F must have $P_1 + G$ for its safe load, i.e.

$$G + P_1 = FT' \quad . \quad . \quad . \quad (1)$$

in which G denotes the weight of the portion of the solid below F . Similarly for the upper base $F + dF$, we have

$$G + P_1 + \gamma F dx = (F + dF) T' \quad . \quad . \quad (2)$$

By subtraction we obtain

$$\gamma F dx = T' dF; \quad \text{i.e.} \quad \frac{\gamma}{T'} dx = \frac{dF}{F}$$

in which the two variables x and F are separated. By integration we now have

$$\frac{\gamma}{T'} \int_0^x dx = \int_{F_0}^F \frac{dF}{F}; \text{ or } \frac{\gamma x}{T'} = \log. \frac{F}{F_0} \dots (3)$$

$$\text{i.e., } F = F_0 e^{\frac{\gamma x}{T'}} = \frac{P_1}{T'} e^{\frac{\gamma x}{T'}} \dots (4)$$

from which F may be computed for any value of x .

The *weight* of the portion below any F is found from (1) and (4); i.e.

$$G = P_1 \left(e^{\frac{\gamma x}{T'}} - 1 \right); \dots (5)$$

while the total extension λ will be

$$\lambda = \epsilon'' \frac{T'}{T''} l \dots (6)$$

the relative elongation $d\lambda \div dx$ being the same for every dx and bearing the same ratio to ϵ'' (at elastic limit), as T' does to T'' .

199. **Tensile Stresses Induced by Temperature.**—If the two ends of a prism are immovably fixed, when under no strain and at a temperature t , and the temperature is then lowered to a value t' , the body suffers a tension proportional to the fall in temperature (within elastic limit). If for a rise or fall of 1° Fahr. (or Cent.) a unit of length of the material would change in length by an amount γ (called the co-efficient of expansion) a length $=l$ would be contracted an amount $\lambda = \gamma l(t-t')$ during the given fall of temperature if one end were free. Hence, if this contraction is prevented by fixing both ends, the rod must be under a tension P , equal in value to the force which would be

necessary to produce the elongation λ , just stated, under ordinary circumstances at the lower temperature.

From eq. (1) §191, therefore, we have for this tension due to fall of temperature

$$P = \frac{E_t F}{l} \eta \lambda (t - t') = E_t F (t - t') \eta$$

For 1° Cent. we may write

For Cast iron	$\eta = .0000111$;
“ Wrought iron	$= .0000120$;
“ Steel	$= .0000108$ to $.0000114$;
“ Copper	$\eta = .0000172$;
“ Zinc	$\eta = .0000300$.

COMPRESSION OF SHORT BLOCKS.

200. Short and Long Column.—In a prism in tension, its own weight being neglected, all the elements between the localities of application of the pair of external forces producing the stretching are in the same state of stress, if the external forces act axially (excepting the few elements in the immediate neighborhood of the forces; these suffering local stresses dependent on the manner of application of the external forces), and the prism may be of any length without vitiating this statement. But if the two external forces are directed *toward* each other the intervening elements will not all be in the same state of compressive stress unless the prism is comparatively short (or unless numerous points of lateral support are provided). A long prism will buckle out sideways, thus even inducing tensile stress, in some cases, in the elements on the convex side.

Hence the distinction between *short blocks* and *long columns*. Under compression the former yield by crushing or splitting, while the latter give way by flexure (i.e. bending). *Long columns*, then will be treated separately

in a subsequent chapter. In the present section the blocks treated being about three or four times as long as wide, all the elements will be considered as being under equal compressive stresses at the same time.

201. Notation for Compression.—By using a subscript *c*, we may write

E_c = Modulus of Elasticity;* i.e. the quotient of the compressive stress per unit of area divided by the relative shortening; also

C = Modulus of crushing; i.e. the force per unit of sectional area necessary to rupture the block by crushing;

C' = Modulus of safe compression, a safe compressive stress per unit of area; and

C'' = Modulus of compression at elastic limit.

For the absolute and relative shortening in length we may still use λ and ϵ , respectively, and within the elastic limit may write equations similar to those for tension, F being the sectional area of the block and P one of the terminal forces, while p = compressive stress per unit of area of F , viz.:

$$E_c = \frac{p}{\epsilon} = \frac{P \div F}{d\lambda + dx} = \frac{P \div F}{\lambda + l} = \frac{Pl}{F\lambda} \dots (1)$$

within the elastic limit.

Also for a short block

$$\left. \begin{aligned} \text{Crushing force} &= FC \\ \text{Compressive force at elastic limit} &= FC'' \\ \text{Safe compressive force} &= FC' \end{aligned} \right\} \dots (2)$$

202. Remarks on Crushing.—As in § 182 for a tensile stress, so for a compressive stress we may prove that a

*[NOTE.—It must be remembered that the modulus of elasticity, whether for normal or shearing stresses, is a number indicative of *stiffness*, not of strength, and has no relation to the elastic limit (except that experiments to determine it must not pass that limit).]

shearing stress $= p \sin a \cos a$ is produced on planes at an angle a with the axis of the short block, p being the compression per unit of area of transverse section. Accordingly it is found that short blocks of many comparatively brittle materials yield by shearing on planes making an angle of about 45° with the axis, the expression $p \sin a \cos a$ reaching a maximum, for $a=45^\circ$; that is, wedge-shaped pieces are forced out from the sides. Hence the necessity of making the block three or four times as long as wide, since otherwise the friction on the ends would cause the piece to show a greater resistance by hindering this lateral motion. Crushing by splitting into pieces parallel to the axis sometimes occurs.

Blocks of *ductile* material, however, yield by swelling out, or bulging, laterally, resembling plastic bodies somewhat in this respect.

The elastic limit is more difficult to locate than in tension, but seems to have a position corresponding to that in tension, in the case of wrought iron and steel. With cast iron, however, the relative compression at elastic limit is about double the relative extension (at elastic limit in tension), but the force producing it is also double. For all three metals it is found that $E_c = E_t$ quite nearly, so that the single symbol E may be used for both.

EXAMPLES IN TENSION AND COMPRESSION.

203. **Tables for Tension and Compression.**—The round numbers of the following tables are to be taken as rude averages only, for use in the numerical examples following. (The scope and design of the present work admit of nothing more. For abundant detail of the results of the more important experiments of late years, the student is referred to the recent works of Profs. Thurston, Burr, Lanza, and Wood). Another column might have been added giving the Modulus of Resilience in each case, viz.: $\frac{1}{2} \epsilon'' T''$ (which also $= \frac{T''^2}{2E_t}$); see § 196. ϵ is an abstract num-

EXAMPLES IN TENSION AND COMPRESSION. 221

ber, and $=\lambda \div l$, while E , T'' , and T are given in pounds per square inch:

TABLE OF THE MODULI, ETC., OF MATERIALS IN TENSION.

Material.	ϵ''	ϵ	E_t	T''	T
	(Elastic limit.)	At Rupture.	Mod. of Elast.	Elastic limit.	Rupture.
	abst. number.	abst. number.	lbs. per sq. in.	lbs. per sq. in.	lbs. per sq. in.
Soft Steel,	.00200	.2500	20,000,000	50,000	80,000
Hard Steel,	.00200	.0500	40,000,000	90,000	130,000
Cast Iron,	.00068	.0020	14,000,000	9,000	18,000
Wro't Iron,	.00080	.2500	28,000,000	22,000	45,000 to 60,000
Brass,	.00100		10,000,000	7,000 to 19,000	16,000 to 50,000
Glass,			9,000,000		3,500
Wood, with	.00200	.0070	200,000	3,000	6,000
the fibres,	to .01100	to .0150	to 2,000,000	to 19,000	to 28,000
Hemp rope,					7,000

[N.B.—Expressed in kilograms per square centim., E_t , T and T'' would be numerically about $\frac{1}{14}$, as large as above, while ϵ and ϵ'' would be unchanged.]

TABLE OF MODULI, ETC.; COMPRESSION OF SHORT BLOCKS.

Material.	ϵ''	ϵ	E_c	C''	C
	Elastic limit.	At rupture.	Mod. of Elast.	Elastic limit.	Rupture.
	abst. number.	abst. number.	lbs. per sq. in.	lbs. per sq. in.	lbs. per sq. in.
Soft Steel.	0.00100		30,000,000	30,000	
Hard Steel.	0.00120	0.3000	40,000,000	50,000	300,000
Cast Iron,	0.00150		14,000,000	20,000	90,000
Wro't Iron,	0.00080	0.3000	28,000,000	24,000	40,000
Glass,					20,000
Granite,			} See § 213a		10,000
Sandstone,					5,000
Brick,					3,000
Wood, with		} 0.0100 to 0.0400	350,000		2,000
the fibres,			to 2,000,000		to 10,000
Portland Cement,			(§ 213a)		4,000

204. **Examples. No. 1.**—A bar of tool steel, of sectional area = 0.097 sq. inches, is ruptured by a tensile force of 14,000 lbs. A portion of its length, originally $\frac{1}{2}$ a foot, is now found to have a length of 0.532 ft. Required T , and ϵ at rupture. Using the inch and pound as units (as in the foregoing tables) we have $T = \frac{14,000}{.097} = 144326$ lbs. per sq. in.; (eq. (2) § 195); while

$$\epsilon = (0.532 - 0.5) \times 12 \div (0.50 \times 12) = 0.064.$$

EXAMPLE 2.—Tensile test of a bar of "Hay Steel" for the Glasgow Bridge, Missouri. The portion measured was originally 3.21 ft. long and 2.09 in. \times 1.10 in. in section. At the elastic limit P was 124,200 lbs., and the elongation was 0.064 ins. Required E_t , T'' , and ϵ'' (for elastic limit).

$$\epsilon'' = \frac{\lambda}{l} = \frac{0.064}{3.21 \times 12} = .00165 \text{ at elastic limit.}$$

$$T'' = 124,200 \div (2.09 \times 1.10) = 54,000 \text{ lbs. per sq. in.}$$

$$E_t = \frac{p}{\epsilon} = \frac{P}{F\epsilon} = \frac{124,200}{2.30 \times .00165} = 32,570,000 \text{ lbs. per sq. in.}$$

Nearly the same result for E_t would probably have been obtained for values of p and ϵ below the elastic limit.

The *Modulus of Resilience* of the above steel (see § 196) would be $\frac{1}{2} \epsilon'' T'' = 44.82$ inch-pounds of work per cubic inch of metal, so that the whole work expended in stretching to the elastic limit the portion above cited is

$$U = \frac{1}{2} \epsilon'' T'' V = 3968. \text{ inch-lbs.}$$

An equal amount of work will be done by the rod in recovering its original length.

EXAMPLE 3.—A hard steel rod of $\frac{1}{2}$ sq. in. section and 20 ft. long is under no stress at a temperature of 130°

Cent., and is provided with flanges so that the slightest contraction of length will tend to bring two walls nearer together. If the resistance to this motion is 10 tons how low must the temperature fall to cause any motion? γ being $=.0000120$ (Cent. scale). From § 199 we have, expressing P in lbs. and F in sq. inches, since $E_t=40,000,000$ lbs. per sq. inch,

$10 \times 2,000 = 40,000,000 \times \frac{1}{2} \times (130-t') \times 0.000012$; whence $t'=46.6^\circ$ Centigrade.

EXAMPLE 4.—If the ends of an iron beam bearing 5 tons at its middle rest upon stone piers, required the necessary bearing surface at each pier, putting C' for stone $=200$ lbs. per sq. inch. 25 sq. in., Ans.

EXAMPLE 5.—How long must a wrought iron rod be, supported vertically at its upper end, to break with its own weight? 216,000 inches, Ans.

EXAMPLE 6.—One voussoir (or block) of an arch-ring presses its neighbor with a force of 50 tons, the joint having a surface of 5 sq. feet; required the compression per sq. inch. 138.8 lbs. per sq. in., Ans.

205. Factor of Safety.—When, as in the case of stone, the value of the stress at the elastic limit is of very uncertain determination by experiment, it is customary to refer the value of the safe stress to that of the ultimate by making it the n 'th portion of the latter. n is called a *factor of safety*, and should be taken large enough to make the safe stress come within the elastic limit. For stone, n should not be less than 10, i.e. $C'=C \div n$; (see Ex. 6, just given).

206. Practical Notes.—It was discovered independently by Commander Beardslee and Prof. Thurston, in 1873, that if wrought iron rods were strained considerably beyond the elastic limit and allowed to remain free from stress

for at least one day thereafter, a second test would show *higher limits* both elastic and ultimate.

When articles of cast iron are imbedded in oxide of iron and subjected to a red heat for some days, the metal loses most of its carbon, and is thus nearly converted into wrought iron, lacking, however, the property of welding. Being malleable, it is called *malleable cast iron*.

Chrome steel (iron and chromium) and tungsten steel possess peculiar hardness, fitting them for cutting tools, rock drills, picks, etc.

By *fatigue of metals* we understand the fact, recently discovered by Wöhler in experiments made for the Prussian Government, that rupture may be produced by causing the stress on the elements to vary repeatedly between two limiting values, the highest of which may be considerably below T (or C), the number of repetitions necessary to produce rupture being dependent both on the range of variation and the higher value.

For example, in the case of Phoenix iron in tension, rupture was produced by causing the stress to vary from 0 to 52,800 lbs. per sq. inch, 800 times; also, from 0 to 44,000 lbs. per sq. inch 240,853 times; while 4,000,000 variations between 26,400 and 48,400 per sq. inch did not cause rupture. Many other experiments were made and the following conclusions drawn (among others):

Unlimited repetitions of variations of stress (lbs. per sq. in.) between the limits given below will not injure the metal (Prof. Burr's Materials of Engineering).

Wrought iron.	{	From 17,600 Comp. to 17,600 Tension.	.
		" 0 to 33,000 "	
Axle Cast Steel.	{	From 30,800 Comp. to 30,800 Tension.	
		" 0 to 52,800 "	
		" 38500 Tens. to 88,000 "	

(See p. 232 for an *addendum* to this paragraph.)

SHEARING.

207. Rivets.—The angular distortion called shearing strain in the elements of a body, is specially to be provided for in the case of *rivets* joining two or more plates. This distortion is shown, in Figs. 205 and 206, in the elements near the plane of contact of the plates, much exaggerated.

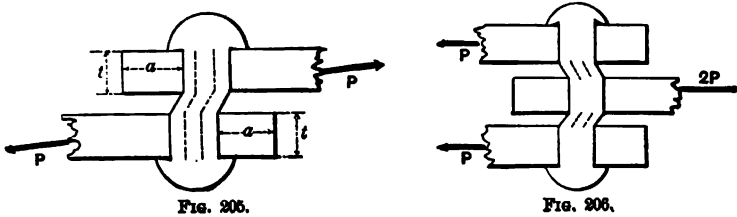

In Fig. 205 (a lap-joint) the rivet is said to be in *single shear*; in Fig. 206 in *double shear*. If P is just great enough to shear off the rivet, the *modulus of ultimate shearing*, which may be called S , (being the shearing force per unit of section when rupture occurs) is

$$S = \frac{P}{F} = \frac{P}{\frac{1}{4}\pi d^2} \dots \dots \dots (1)$$

in which F —the cross section of the rivet, its diameter being $=d$. For safety a value $S' = \frac{1}{4}$ to $\frac{1}{6}$ of S should be taken for metal, in order to be within the elastic limit.

As the width of the plate is diminished by the rivet hole the remaining sectional area of the plate should be ample to sustain the tension P , or $2P$, (according to the plate considered, see Fig. 206), P being the safe shearing force for the rivet. Also the thickness t of the plate should be such that the side of the hole shall be secure against crushing; P must not be $> C'td$, Fig. 205.

Again, the distance a , Fig. 205, should be such as to prevent the tearing or shearing out of the part of the plate between the rivet and edge of the plate.

For economy of material the seam or joint should be no more liable to rupture by one than by another, of the

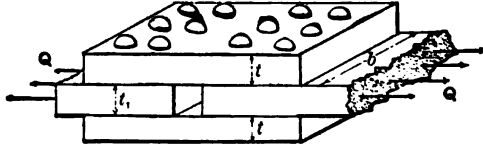

FIG. 207.

four modes just mentioned. The relations which must then subsist will be illustrated in the case of the “butt-joint” with two cover-plates, Fig. 207. Let the dimensions be denoted as in the figure and the total tensile force on the joint be = Q . Each rivet (see also Fig. 206) is exposed in each of two of its sections to a shear of $\frac{1}{2} Q$, hence for safety against shearing of rivets we put

$$\frac{1}{2} Q = \frac{1}{4} \pi d^2 S' \quad \dots \dots \dots (1)$$

Along one row of rivets in the main plate the sectional area for resisting tension is reduced to $(b - 3d)t$, hence for safety against rupture of that plate by the tension Q , we put

$$Q = (b - 3d)t T' \quad \dots \dots \dots (2)$$

Equations (1) and (2) suffice to determine d for the rivets and t_1 for the main plates, Q and b being given; but the values thus obtained should also be examined with reference to the compression in the side of the rivet hole, i.e., $\frac{1}{6} Q$ must not be $> C't_1d$. [The distance a , Fig. 205, to the edge of the plate is recommended by different authorities to be from d to $3d$.]

Similarly, for the cover-plate we must have

$$\frac{1}{2} Q \text{ or } (b - 3d)t_1 T' \quad \dots \dots \dots (3)$$

and $\frac{1}{2} Q$ not $> C't_1d$.

If the rivets do not fit their holes closely, a large margin should be allowed in practice. Again, in boiler work, the *pitch*, or distance between centers of two consecutive rivets may need to be smaller, to make the joint steam-tight, than would be required for strength alone.

208. Shearing Distortion.—The change of form in an element due to shearing is an angular deformation and will be measured in π -measure. This angular change or difference between the value of the corner angle during strain and $\frac{1}{2}\pi$, its value before strain, will be called δ , and is proportional (within elastic limit) to the shearing stress per unit of area, p_s , existing on all the four faces whose angles with each other have been changed.

Fig. 208. (See § 181). By § 184 the **Modulus of Shearing Elasticity** is the quotient obtained by dividing p_s by δ ; i.e. (*elastic limit not passed*),

$$E_s = \frac{p_s}{\delta} \quad . \quad . \quad . \quad . \quad (1)$$

or inversely,
$$\delta = p_s \div E_s \quad . \quad . \quad . \quad . \quad (1')$$

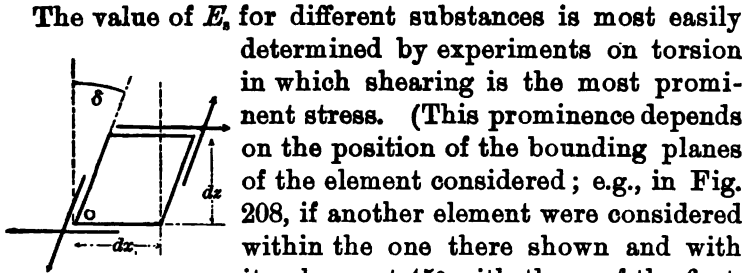

FIG. 208.

The value of E_s for different substances is most easily determined by experiments on torsion in which shearing is the most prominent stress. (This prominence depends on the position of the bounding planes of the element considered; e.g., in Fig. 208, if another element were considered within the one there shown and with its planes at 45° with those of the first, we should find tension alone on one pair of opposite faces, compression alone on the other pair.) It will be noticed that shearing stress cannot be present on two opposite faces only, but exists also on another pair of faces (those perpendicular to the stress on the first), forming a couple of equal and opposite moment to the first, this being necessary for the equilibrium of the element, even when

tensile or compressive stresses are also present on the faces considered.

209. Shearing Stress is Always of the Same Intensity on the Four Faces of an Element.—(By *intensity* is meant *per unit of area*; and the four faces referred to are those perpendicular to the paper in Fig. 208, the shearing stress being parallel to the paper.)

Let dx and dz be the width and height of the element in Fig. 208, while dy is its thickness perpendicular to the paper. Let the *intensity* of the shear on the right hand face be $=q_s$, that on the top face $=p_s$. Then for the element as a free body, taking moments about the axis O perpendicular to paper, we have

$$q_s \, dz \, dy \times dx - p_s \, dx \, dy \times dz = 0 \therefore q_s = p_s$$

(dx and dz being the respective lever arms of the forces $q_s \, dz \, dy$ and $p_s \, dx \, dy$.)

Even if there were also tensions (or compressions) on one or both pairs of faces their moments about O would balance (or fail to do so by a differential of a higher order) independently of the shears, and the above result would still hold.

210. Table of Moduli for Shearing.

Material.	δ''	E_s	S''	S
	i.e. δ at elastic limit.	Mod. of Elasticity for Shearing.	(Elastic limit.)	(Rupture.)
	arc in π -measure.	lbs. per sq. in.	lbs. per sq. in.	lbs. per sq. in.
Soft Steel,		9,000,000		70,000
Hard Steel,	0.0082	14,000,000	45,000	90,000
Cast Iron,	0.0021	7,000,000	15,000	30,000
Wrought Iron,	0.0022	9,000,000	30,000	50,000
Brass,		5,000,000		
Glass,				
Wood, across fibre,				1,500 to 8,000
Wood, along fibre,				500 to 1,200

As in the tables for tension and compression, the above values are averages. The true values may differ from these as much as 30 per cent. in particular cases, according to the quality of the specimen.

211. Punching rivet holes in plates of metal requires the overcoming of the shearing resistance along the convex surface of the cylinder punched out. Hence if d = diameter of hole, and t = the thickness of the plate, the necessary force for the punching, the surface sheared being $F = \pi d t$, is

$$P = S t \pi d \quad . \quad . \quad . \quad . \quad (2)$$

Another example of shearing action is the "stripping" of the threads of a screw, when the nut is forced off longitudinally without turning, and resembles punching in its nature.

212. E and E_s ; Theoretical Relation.—In case a rod is in tension within the elastic limit, the relative (linear) lateral contraction (let this = m) is so connected with E_t and E_s , that if two of the three are known the third can be deduced theoretically. This relation is proved as follows, by Prof. Burr. Taking an elemental cube with four of its faces at 45° with the axis of the piece, Fig. 209, the axial half-diagonal AD becomes of a length $AD' = AD + \epsilon \cdot AD$ under stress, while the transverse half diagonal contracts to a length $B'D' = AD - m \cdot AD$. The angular distortion δ

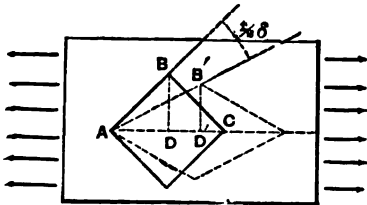

FIG. 209. § 212.

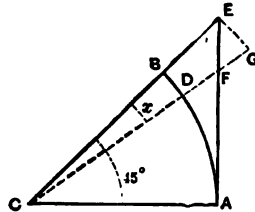

FIG. 210.

is supposed very small compared with 90° and is due to the shear p_s per unit of area on the face BC (or BA). From the figure we have

$$\tan(45^\circ - \frac{\delta}{2}) = \frac{B'D'}{AD'} = \frac{1-m}{1+\epsilon} = 1-m-\epsilon, \text{ approx.}$$

[But, Fig. 210, $\tan(45^\circ - x) = 1 - 2x$ nearly, where x is a small angle, for, taking $\overline{CA} = \text{unity} = AE$, $\tan AD = AF = AE - EF$. Now approximately $\overline{EF} = \overline{EG} \cdot \sqrt{2}$ and $\overline{EG} = \overline{BD} \sqrt{2} = x \sqrt{2} \therefore AF = 1 - 2x$ nearly.] Hence

$$1 - \delta = 1 - m - \epsilon; \text{ or } \delta = m + \epsilon \quad . \quad . \quad (2)$$

Eq. (2) holds good whatever the stresses producing the deformation, but in the present case of a rod in tension, if it is an isotrope, and if $p =$ tension per unit of area on its transverse section, (see § 182, putting $a = 45^\circ$), we have $E_t = p \div \epsilon$ and $E_s = (p_s \text{ on } BC) \div \delta = \frac{1}{2} p \div \delta$. Putting also $(m : \epsilon) = r$, whence $m = r\epsilon$, eq. (2) may finally be written

$$\frac{1}{2E_s} = (r+1) \frac{1}{E_t}; \text{ i.e., } E_s = \frac{E_t}{2(1+r)} \quad . \quad . \quad (3)$$

Prof. Bauschinger, experimenting with cast iron rods, found that in tension the ratio $m : \epsilon$ was $= \frac{2}{100}$, as an average, which in eq. (3) gives

$$E_s = \frac{100}{246} E_t = \frac{2}{5} E_t \text{ nearly.} \quad . \quad . \quad . \quad (4)$$

His experiments on the torsion of cast iron rods gave $E_s = 6,000,000$ to $7,000,000$ lbs. per sq. inch. By (4), then, E_t should be $15,000,000$ to $17,500,000$ which is approximately true (§ 203).

Corresponding results may be obtained for short blocks in compression, the lateral change being a dilatation instead of a contraction.

§13. Examples in Shearing.—EXAMPLE 1.—Required the proper length, a , Fig. 211, to guard against the shearing off, along the grain, of the portion ab , of a wooden tie-rod, the force P being = 2 tons, and the width of the tie = 4 inches. Using a value of $S' = 100$ lbs. per sq. in., we put $baS' = 4,000 \cos 45^\circ$; i.e. $a = (4,000 \times 0.707) \div (4 \times 100) = 7.07$

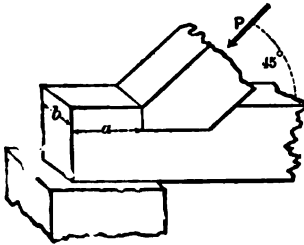

FIG. 211.

inches.

EXAMPLE 2.—A $\frac{7}{8}$ in. rivet of wrought iron, in *single shear* (see Fig. 205) has an ultimate shearing strength $P = FS = \frac{1}{4}\pi d^2 S = \frac{1}{4}\pi (\frac{7}{8})^2 \times 50,000 = 30,050$ lbs. For safety, putting $S' = 8,000$ instead of S , $P' = 4,800$ lbs. is its safe shearing strength in single shear.

The wrought iron plate, to be secure against the side-crushing in the hole, should have a thickness t , computed thus :

$$P' = tdC'; \text{ or } 4,800 = t \cdot \frac{7}{8} \times 12,000 \therefore t = 0.46 \text{ in.}$$

If the plate were only 0.23 in. thick the safe value of P would be only $\frac{1}{2}$ of 4,800.

EXAMPLE 3.—Conversely, given a lap-joint, Fig. 205, in which the plates are $\frac{1}{4}$ in. thick and the tensile force on the joint = 600 lbs. per linear inch of seam, how closely must $\frac{3}{4}$ inch rivets be spaced in one row, putting $S' = 8,000$ and $C' = 12,000$ lbs. per sq. in.? Let the distance between centres of rivets be = x (in inches), then the force upon each rivet = $600x$, while its section $F = 0.44$ sq. in. Having regard to the shearing strength of the rivet we put $600x = 0.44 \times 8,000$ and obtain $x = 5.86$ in.; but considering that the safe crushing resistance of the hole is = $\frac{1}{4} \cdot \frac{3}{4} \cdot 12,000 = 2,250$ lbs., $600x = 2,250$ gives $x = 3.75$ inches, which is the pitch to be adopted. What is the tensile strength of the reduced sectional area of the plate, with this pitch?

EXAMPLE 4.—Double butt-joint; (see Fig. 207); $\frac{3}{8}$ inch plate; $\frac{3}{4}$ in. rivets; $T=C'=12,000$; $S'=8,333$; width of plates=14 inches. Will one row of rivets be sufficient at each side of joint, if $Q=30,000$ lbs.? The number of rivets = ? Here each rivet is in double shear and has therefore a double strength as regards shear. In double shear the safe strength of each rivet $=2FS'=7,333$ lbs. Now $30,000 \div 7,333=4.0$ (say). With the four rivets in one row the reduced sectional area of the main plate is $= [14 - 4 \times \frac{3}{4}] \times \frac{3}{8} = 4.12$ sq. in., whose safe tensile strength is $=FT'=4.12 \times 12,000=49,440$ lbs.; which is $> 30,000$ lbs. \therefore main plate is safe in this respect. But as to side-crushing in holes in main plate we find that $C't_d$ (i.e. $12,000 \times \frac{3}{8} \times \frac{3}{4} = 3,375$ lbs.) is $< \frac{1}{4} Q$ i.e. $< 7,500$ lbs., the actual force on side of hole. Hence four rivets in one row are too few unless thickness of main plate be doubled. Will eight in one row be safe?

213a. (Addendum to § 206.) **Elasticity of Stone and Cement.**—Experiments by Gen. Gillmore with the large Watertown testing-machine in 1883 resulted as follows (see p. 221 for notation):

With cubes of Haverstraw Freestone (a homogeneous brown-stone) from 1 in. to 12 in. on the edge, E_c was found to be from 900,000 to 1,000,000 lbs. per sq. in. approximately; and C about 4,000 or 5,000 lbs. per sq. in. Cubes of the same range of sizes of Dyckerman's Portland cement gave E_c from 1,350,000 to 1,630,000, and C from 4,000 to 7,000, lbs. per sq. in. Cubes of concrete of the above sizes, made with the Newark Cc.'s Rosendale cement, gave E_c about 538,000, while cubes of cement-mortar, and some of concrete, both made with National Portland cement, showed E_c from 800,000 to 2,000,000 lbs. per sq. in.

The compressibility of *brick piers* 12 in. square in section and 16 in. high was also tested. They were made of common North River brick with mortar joints $\frac{3}{8}$ in. thick, and showed a value for E_c of about 300,000 or 400,000, while at elastic limit C'' was on the average 1,000, lbs. per sq. in.

CHAPTER II.

TORSION.

214. Angle of Torsion and of Helix. When a cylindrical beam or shaft is subjected to a twisting or torsional action, i.e. when it is the means of holding in equilibrium two couples in parallel planes and of equal and opposite moments, the longitudinal axis of symmetry remains straight and the elements along it experience no stress (whence it may be called the "line of no twist"), while the lines originally parallel to it assume the form of helices, each element of which is distorted in its angles (originally right angles), the amount of distortion being assumed proportional to the radius of the helix. The directions of the

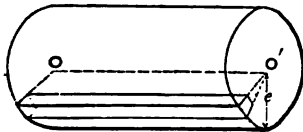

FIG. 212.

faces of any element were originally as follows : two radial, two in consecutive transverse sections, and the other two tangent to two consecutive circular cylinders whose common axis is that of the shaft. E.g. in Fig. 212 we have an unstrained shaft, while in Fig. 213 it holds the two

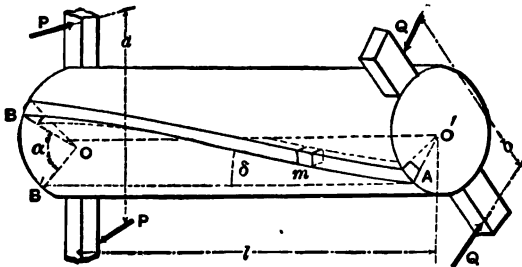

FIG. 213.

faces of any element were originally as follows : two radial, two in consecutive transverse sections, and the other two tangent to two consecutive circular cylinders whose common axis is that of the shaft. E.g. in Fig. 212 we have an unstrained shaft, while in Fig. 213 it holds the two

couples (of equal moment $Pa = Qb$) in equilibrium. These couples act in parallel planes perpendicular to the axis of the prism and a distance, l , apart. Assuming that the transverse sections *remain plane and parallel* during torsion, any surface element, m , which in Fig. 212 was entirely right-angled, is now distorted. Two of its angles have been increased, two diminished, by an amount δ , the angle between the helix and a line parallel to the axis. Supposing m to be the most distant of any element from the axis, this distance being e , any other element at a distance x

from the axis experiences an angular distortion $-\frac{x}{e} \delta$.

If now we draw OB parallel to $O'A$ the angle BOB' , $=\alpha$, is called the **Angle of Torsion**, while δ may be called the *helix angle*; the former lies in a transverse plane, the latter in a plane tangent to the cylinder. Now

$\tan \delta = (\text{linear arc } BB') \div l$; but $\text{lin. arc } BB' = e\alpha$; hence, putting δ for $\tan \delta$, (δ being small)

$$\delta = \frac{e\alpha}{l} \dots \dots \dots (1)$$

(δ and α both in π measure).

215. Shearing Stress on the Elements. The angular distortion, or shearing strain, δ , of any element (bounded as already described) is due to the shearing stresses exerted on it by its neighbors on the four faces perpendicular to the

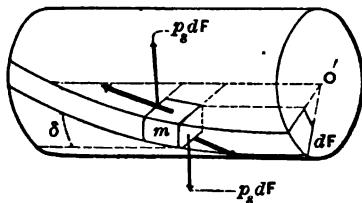

FIG. 214.

tangent plane of the cylindrical shell in which the element is situated. Consider these neighboring elements of an *outside element* removed, and the stresses put in; the latter are accountable for the distortion of the element and so

hold it in equilibrium. Fig. 214 shows this element "free." Within the elastic limit δ is known to be proportional to p_s , the shearing stress per unit of area on the faces whose relative angular positions have been changed. That is, from eq. (1) § 208, $\delta = p_s \div E_s$; whence, see (1) of § 214,

$$p_s = \frac{e a E_s}{l} \dots \dots \dots (2)$$

In (2) p_s and e both refer to a surface element, e being the radius of the cylinder, and p_s the greatest intensity of shearing stress existing in the shaft. Elements lying nearer the axis suffer shearing stresses of less intensity in proportion to their radial distances, i.e., to their helix-angles. That is, the shearing stress on that face of the element which forms a part of a transverse section and whose distance from the axis is z , is $p_z = \frac{z}{e} p_s$, per unit of area, and the total shear on the face is $p_z dF$, dF being the area of the face.

216. Torsional Strength.—We are now ready to expose the full transverse section of a shaft under torsion, to deduce formulæ of practical utility. Making a right section of the shaft of Fig. 213 anywhere between the two couples and considering the left hand portion as a free body, the forces holding it in equilibrium are the two forces P of the left-hand couple and an infinite number of shearing forces, each tangent to its circle of radius z , on the cross section exposed by the removal of the right-hand portion. The cross section is assumed to remain plane during torsion, and is composed of an infinite number of dF 's, each being the area of an exposed face of an element; see Fig. 215.

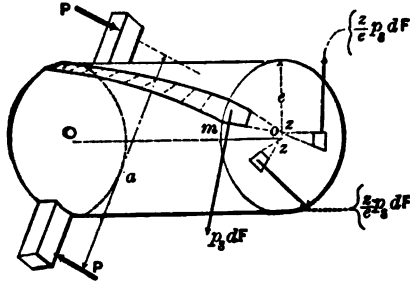

FIG. 215.

Each elementary shearing force = $\frac{z}{e} p_s dF$, and z is its lever arm about the axis Oo . For equilibrium, Σ (mom.) about the axis Oo must = 0; i.e. in detail

$$-P\frac{1}{2}a - P\frac{1}{2}a + \int \left(\frac{z}{e} p_s dF\right) z = 0$$

or, reducing,

$$\frac{p_s}{e} \int z^2 dF = Pa; \text{ or, } \frac{p_s I_p}{e} = Pa \quad . \quad . \quad (3)$$

Eq. (3) relates to *torsional strength*, since it contains p_s , the greatest shearing stress induced by the torsional couple, whose moment Pa is called the **Moment of Torsion**, the stresses in the cross section forming a couple of equal and opposite moment.

I_p is recognized as the **Polar Moment of Inertia** of the cross section, discussed in § 94; e is the radial distance of the outermost element, and = the radius for a circular shaft.

217. Torsional Stiffness.—In problems involving the angle of torsion, or deformation of the shaft, we need an equation connecting Pa and a , which is obtained by substituting in eq. (3) the value of p_s in eq. (2), whence

$$\frac{a I_p E_s}{l} = Pa \quad . \quad . \quad . \quad (4)$$

From this it appears that the angle of torsion, α , is proportional to the moment of torsion, Pa , within the elastic limit; α must be expressed in π -measure. Trautwine cites 1° (i.e. $\alpha=0.0174$) as a maximum allowable value for shafts.

218. Torsional Resilience is the work done in twisting a shaft from an unstrained state until the elastic limit is reached in the outermost elements. If in Fig. 213 we imagine the right-hand extremity to be fixed, while the other end is gradually twisted through an angle α_1 each force P of the couple must be made to increase gradually from a zero value up to the value P_1 , corresponding to α_1 . In this motion each end of the arm a describes a space $= \frac{1}{2}a\alpha_1$, and the mean value of the force $= \frac{1}{2}P_1$ (compare § 196). Hence the work done in twisting is

$$U_1 = \frac{1}{2}P_1 \times \frac{1}{2}a\alpha_1 \times 2 = \frac{1}{2}P_1 a \alpha_1 \quad . \quad . \quad (5)$$

By the aid of preceding equations, (5) can be written

$$U_1 = \frac{\alpha_1^2 E_s I_p}{2l}, \text{ or } = \frac{P_1^2 a^2 l}{2I_p E_s}, \text{ or } = \frac{p_s^2 I_p l}{2E_s e^2} \quad . \quad . \quad (6)$$

If for p_s we write S' (Modulus of safe shearing) we have for the *safe resilience* of the shaft

$$U' = \frac{S'^2 I_p l}{2E_s e^2} \quad . \quad . \quad . \quad (7)$$

If the torsional elasticity of an originally unstrained shaft is to be the means of arresting the motion of a moving mass whose weight is G , (large compared with the parts intervening) and velocity $=v$, we write (§ 133)

$$U' = \frac{G}{g} \cdot \frac{v^2}{2};$$

as the condition that the shaft shall not be injured.

219. Polar Moment of Inertia.—For a shaft of circular cross section (see § 94) $I_p = \frac{1}{2}\pi r^4$; for a hollow cylinder $I_p = \frac{1}{2}\pi(r_1^4 - r_2^4)$; while for a square shaft $I_p = \frac{1}{6}b^4$, b being the side of the square; for a rectangular cross-section sides b and h , $I_p = \frac{1}{12}bh(b^2 + h^2)$. For a cylinder $e = r$; if hollow, $e = r$, the greater radius. For a square, $e = \frac{1}{2}b\sqrt{2}$.

220. Non-Circular Shafts.—If the cross-section is not circular it becomes warped, in torsion, instead of remaining plane. Hence the foregoing theory does not strictly apply. The celebrated investigations of St. Venant, however, cover many of these cases. (See § 708 of Thompson and Tait's Natural Philosophy; also, Prof. Burr's Elasticity and Strength of the Materials of Engineering). His results give for a square shaft (instead of the

$$\frac{ab^4 E_s}{6l} = Pa \text{ of eq. (4) of § 217),}$$

$$Pa = 0.841 \frac{ab^4 E_s}{6l} \quad . \quad . \quad . \quad . \quad (1)$$

and $Pa = \frac{1}{6}b^3 p_s$, instead of eq. (3) of § 216, p_s being the greatest shearing stress.

The elements under greatest shearing strain are found at the middles of the sides, instead of at the corners, when the prism is of square or rectangular cross-section. The warping of the cross-section in such a case is easily verified by the student by twisting a bar of india-rubber in his fingers.

221. Transmission of Power.—Fig. 216. Suppose the cog-

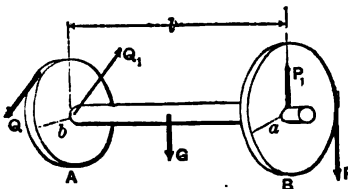

FIG. 216.

wheel B to cause A , on the same shaft, to revolve uniformly and overcome a resistance Q , the pressure of the teeth of another cog-wheel, B being driven by still another wheel. The shaft AB is un-

der torsion, the moment of torsion being $= Pa = Qb$. (P_1 and Q_1 the bearing reactions have no moment about the axis of the shaft). If the shaft makes u revolutions per unit-time, the work transmitted (*transmitted*; not *expended* in twisting the shaft whose angle of torsion remains constant, corresponding to Pa) per unit-time, i.e. the Power, is

$$L = P \cdot 2\pi a \cdot u = 2\pi u Pa \quad . \quad . \quad . \quad (8)$$

To reduce L to Horse Power (§ 132), we divide by N , the number of units of work per unit-time constituting one H. P. in the system of units employed, i.e.,

$$\text{Horse Power} = \text{H. P.} = \frac{2\pi u Pa}{N}$$

For example $N = 33,000$ ft.-lbs. per minute, or $= 396,000$ inch-lbs. per minute; or $= 550$ ft.-lbs. per second. Usually the rate of rotation of a shaft is given in revolutions per minute.

But eq. (8) happens to contain Pa the moment of torsion acting to maintain the constant value of the angle of torsion, and since for safety (see eq. (3) § 216) $Pa = S' I_p \div e$, with $I_p = \frac{1}{2} \pi r^4$ and $e = r$ for a solid circular shaft, we have for such a shaft

$$(\text{Safe}), \text{H. P.} = \frac{\pi^2 S' u r^3}{N} \quad . \quad . \quad . \quad (9)$$

which is the safe H. P., which the given shaft can transmit at the given speed. S' may be made 7,000 lbs. per sq. inch for wrought iron; 10,000 for steel, and 5,000 for cast-iron. If the value of Pa fluctuates periodically, as when a shaft is driven by a connecting rod and crank, for (H. P.) we put $m \times (\text{H. P.})$, m being the ratio of the maximum to the mean torsional moment; $m =$ about $1\frac{1}{2}$, under ordinary circumstances (Cotterill).

222. Autographic Testing Machine.—The principle of Prof Thurston's invention bearing this name is shown in Fig

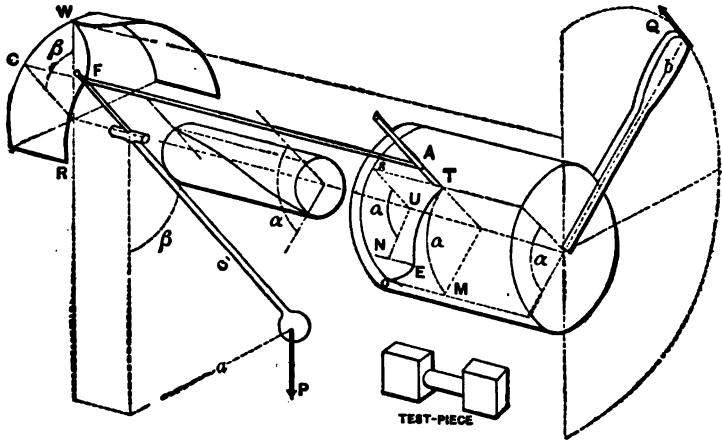

FIG. 217.

217. The test-piece is of a standard shape and size, its central cylinder being subjected to torsion. A jaw, carrying a handle (or gear-wheel turned by a worm) and a drum on which paper is wrapped, takes a firm hold of one end of the test-piece, whose further end lies in another jaw rigidly connected with a heavy pendulum carrying a pencil free to move axially. By a continuous slow motion of the handle the pendulum is gradually deviated more and more from the vertical, through the intervention of the test-piece, which is thus subjected to an increasing torsional moment. The axis of the test-piece lies in the axis of motion. This motion of the pendulum by means of a properly curved guide, WR , causes an axial (i.e., parallel to axis of test-piece) motion of the pencil A , as well as an angular deviation β equal to that of the pendulum, and this axial distance $CF, = sT$, of the pencil from its initial position measures the moment of torsion $= Pa = Pc \sin \beta$. As the piece twists, the drum and paper move relatively to the pencil through an angle sUo equal to the angle

of torsion α so far attained. The abscissa $s\theta$ and ordinate sT of the curve thus marked on the paper, measure, when the paper is unrolled, the values of α and Pa through all the stages of the torsion. Fig. 218 shows typical

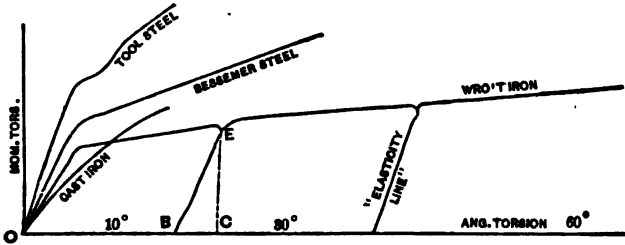

FIG. 218.

curves thus obtained. Many valuable indications are given by these strain diagrams as to homogeneousness of composition, ductility, etc., etc. On relaxing the strain at any stage within the elastic limit, the pencil retraces its path; but if beyond that limit, a new path is taken called an "elasticity-line," in general parallel to the first part of the line, and showing the amount of angular recovery, BC , and the permanent angular set, OB .

223. Examples in Torsion.—The modulus of safe shearing strength, S' , as given in § 221, is expressed in pounds per square inch; hence these two units should be adopted throughout in any numerical examples where one of the above values for S' is used. The same statement applies to the modulus of shearing elasticity, E_s , in the table of § 210.

EXAMPLE 1.—Fig. 216. With $P = 1$ ton, $a = 3$ ft., $l = 10$ ft., and the radius of the cylindrical shaft $r = 2.5$ inches, required the max. shearing stress per sq. inch, p_s , the shaft being of wrought iron. From eq. (3) § 216

$$p_s = \frac{Pae}{I_p} = \frac{2,000 \times 36 \times 2.5}{\frac{1}{2}\pi \times (2.5)^4} = 2,930 \text{ lbs. per sq. inch,}$$

which is a safe value for any ferrous metal.

EXAMPLE 2.—What H. P. is the shaft in Ex. 1 transmitting, if it makes 50 revolutions per minute? Let u = number of revolutions per unit of time, and N = the number of units of work per unit of time constituting one horse-power. Then $H. P. = Pu2\pi a \div N$, which for the foot-pound-minute system of units gives

$$H. P. = 2,000 \times 50 \times 2\pi \times 3 \div 33,000 = 57\frac{1}{4} \text{ H. P.}$$

EXAMPLE 3.—What different radius should be given to the shaft in Ex. 1, if two radii at its extremities, originally parallel, are to make an angle of 2° when the given moment of torsion is acting, the strains in the shaft remaining constant. From eq. (4) § 217, and the table 210, with $a = \frac{\pi}{180}\pi = 0.035$ radians (i.e. π -measure), and $I_p = \frac{1}{2}\pi r^4$, we have

$$r^4 = \frac{2,000 \times 36 \times 120}{\frac{1}{2}\pi \times 0.035 \times 9,000,000} = 17.45 \therefore r = 2.04 \text{ inches.}$$

(This would bring about a different p_s , but still safe.) The foregoing is an example in *stiffness*.

EXAMPLE 4.—A working shaft of steel (solid) is to transmit 4,000 H. P. and make 60 rev. per minute, the maximum twisting moment being $1\frac{1}{2}$ times the average; required its diameter. $d = 14.74$ inches. Ans.

EXAMPLE 5.—In example 1, $p_s = 2,930$ lbs. per square inch; what tensile stress does this imply on a plane at 45° with the pair of planes on which p_s acts? Fig. 219 shows

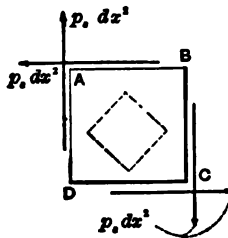

FIG. 219.

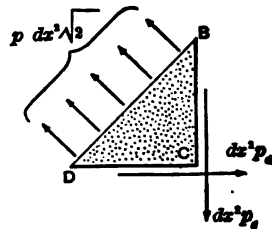

FIG. 220.

a small cube, of edge $=dx$, (taken from the outer helix of Fig. 215,) free and in equilibrium, the plane of the paper being tangent to the cylinder; while 220 shows the portion BDC , also free, with the unknown total tensile stress $pdx^2\sqrt{2}$ acting on the newly exposed rectangle of area $=dx \times dx\sqrt{2}$, p being the unknown stress per unit of area. From symmetry the stress on this diagonal plane has no shearing component. Putting Σ [components normal to BD] $=0$, we have

$$pdx^2\sqrt{2}=2dx^2p_s\cos 45^\circ=dx^2p_s\sqrt{2}\therefore p=p_s. \quad (1)$$

That is, a normal tensile stress exists in the diagonal plane BD of the cubical element equal in intensity to the shearing stress on one of the faces, i.e., $=2,930$ lbs. per sq. in. in this case.

Similarly in the plane AC will be found a compressive stress of $2,930$ lbs. per sq. in. If a plane surface had been exposed making any other angle than 45° with the face of the cube in Fig. 219, we should have found shearing and normal stresses each less than p_s per sq. inch. Hence the interior dotted cube in 219, if shown "free" is in tension in one direction, in compression in the other, and with no shear, these normal stresses having equal intensities. Since S' is usually less than T' or C' , if p_s is made $=S'$ the tensile and compressive actions are not injurious. It follows therefore that when a cylinder is in torsion any helix at an angle of 45° with the axis is a line of tensile, or of compressive stress, according as it is a right or left handed helix, or vice versâ.

EXAMPLE 6.—A solid and a hollow cylindrical shaft, of equal length, contain the same amount of the same kind of metal, the solid one fitting the hollow of the other.

Compare their torsional strengths, used separately. The solid shaft has only $\frac{471}{1,000}$ the strength of the hollow one. Ans.

CHAPTER III.

FLEXURE OF HOMOGENEOUS PRISMS UNDER PERPENDICULAR FORCES IN ONE PLANE.

224. Assumptions of the Common Theory of Flexure.—When a prism is bent, under the action of external forces perpendicular to it and in the same plane with each other, it may be assumed that the longitudinal fibres are in tension on the convex side, in compression on the concave side, and that the relative stretching or contraction of the elements is proportional to their distances from a plane intermediate between, with the understanding that the flexure is slight and that the elastic limit is not passed in any element.

This “common theory” is sufficiently exact for ordinary engineering purposes if the constants employed are properly determined by a wide range of experiments, and involves certain assumptions of as simple a nature as possible, consistently with practical facts. These assumptions are as follows, (for prisms, and for solids with variable cross sections, when the cross sections are similarly situated as regards a central straight axis) and are approximately borne out by experiment:

- (1.) The external or “applied” forces are all perpendicular to the axis of the piece and lie in one plane, which may be called the force-plane; the force-plane contains the axis of the piece and cuts each cross-section symmetrically;
- (2.) The cross-sections remain plane surfaces during flexure;
- (3.) There is a surface (or, rather, sheet of elements) which is parallel to the axis and perpendicular to the force-plane, and along which the elements of the solid ex-

perience no tension nor compression in an axial direction, this being called the **Neutral Surface**;

(4.) The projection of the neutral surface upon the force plane (or a \perp plane) being called the **Neutral Line** or **Elastic Curve**, the bending or flexure of the piece is so slight that an elementary division, ds , of the neutral line may be put $=dx$, its projection on a line parallel to the direction of the axis before flexure;

(5.) The elements of the body contained between any two consecutive cross-sections, whose intersections with the neutral surface are the respective **Neutral Axes** of the sections, experience elongations (or contractions, according as they are situated on one side or the other of the neutral surface), in an axial direction, whose amounts are proportional to their distances from the neutral axis, and indicate corresponding tensile or compressive stresses;

(6.) $E_t = E_c$;

(7.) The dimensions of the cross-section are small compared with the length of the piece;

(8.) There is no shear perpendicular to the force plane on internal surfaces perpendicular to that plane.

In the locality where any one of the external forces is applied, local stresses are of course induced which demand separate treatment. These are not considered at present.

225. Illustration.—Consider the case of flexure shown in **Fig. 221**. The external forces are three (neglecting the

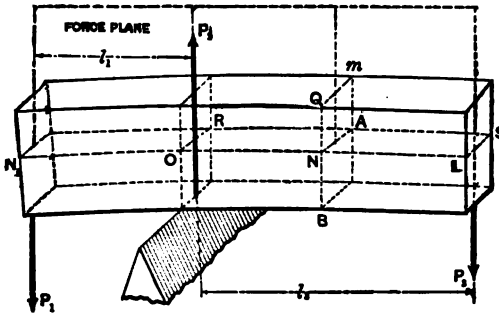

FIG. 221.

weight of the beam), viz.: P_1 , P_2 , and P_3 . P_1 and P_3 are loads, P_2 the reaction of the support.

The force plane is vertical. N_1L is the neutral line or elastic curve. NA is the neutral axis of the cross-section at m ; this cross-section, originally perpendicular to the sides of the prism, is during flexure \perp to their tangent planes drawn at the intersection lines; in other words, the side view QNB , of any cross-section is perpendicular to the neutral line. In considering the whole prism free we have the system P_1 , P_2 , and P_3 in equilibrium, whence from $\Sigma Y=0$ we have $P_2=P_1+P_3$, and from Σ (mom. about O) $=0$, $P_3l_3=P_1l_1$. Hence given P_1 we may determine the other two external forces. A reaction such as P_2 is sometimes called a supporting force. The elements above the neutral surface N_1OLS are in tension; those below in compression (in an axial direction).

226. The Elastic Forces.—Conceive the beam in Fig. 221 separated into two parts by any transverse section such as QA , and the portion N_1ON , considered as a free body in Fig. 222. Of this free body the surface QAB is one of

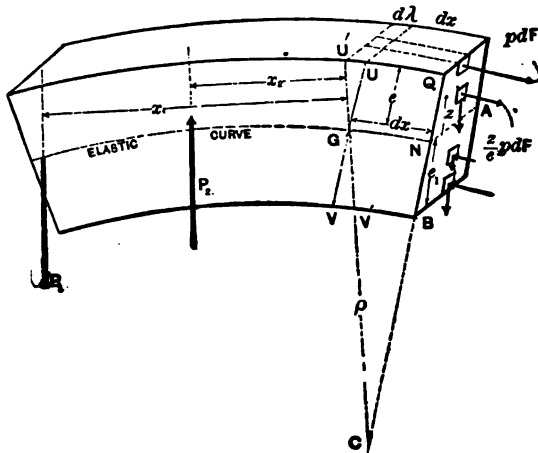

FIG. 222.

the bounding surfaces, but was originally an internal surface of the beam in Fig. 221. Hence in Fig. 222 we must put in the stresses acting on all the dF 's or elements of area of QAB . These stresses represent the actions of the body taken away upon the body which is left, and according to assumptions (5), (6) and (8) consist of normal stresses (tension or compression) proportional per unit of area, to the distance, z , of the dF 's from the neutral axis, and of shearing stresses parallel to the force-plane (which in most cases will be vertical).

The intensity of this shearing stress on any dF varies with the position of the dF with respect to the neutral axis, but the law of its variation will be investigated later (§§ 253 and 254). These stresses, called the **Elastic Forces** of the cross-section exposed, and the external forces P_1 and P_2 , form a system in equilibrium. We may therefore apply any of the conditions of equilibrium proved in § 38.

227. The Neutral Axis Contains the Centre of Gravity of the Cross-Section.—Fig. 222. Let e = the distance of the *outermost* element of the cross-section from the neutral axis, and the normal stress per unit of area upon it be $=p$, whether tension or compression. Then by assumptions (5) and (6), § 224, the intensity of normal stress on any dF is $=\frac{z}{e}p$ and the actual

$$\text{normal stress on any } dF \text{ is } = \frac{z}{e} pdF \quad . \quad (1)$$

This equation is true for dF 's having negative z 's, i.e. on the other side of the neutral axis, the negative value of the force indicating normal stress of the opposite character; for if the relative elongation (or contraction) of two axial fibres is the same for equal z 's, one above, the other below, the neutral surface, the stresses producing the changes in length are also the same, provided $E_t = E_c$; see §§ 184 and 201.

For this free body in equilibrium put $\Sigma X=0$ (X is a horizontal axis). Put the normal stresses equal to their X components, the flexure being so slight, and the X component of the shears = 0 for the same reason. This gives (see eq. (1))

$$\int \frac{z}{e} p dF = 0; \text{ i.e. } \frac{P}{e} \int dFz = 0; \text{ or, } \frac{P}{e} F\bar{z} = 0 \quad (2)$$

In which \bar{z} = distance of the centre of gravity of the cross-section from the neutral axis, from which, though unknown in position, the z 's have been measured (see eq. (4) § 23).

In eq. (2) neither $p \div e$ nor F can be zero $\therefore \bar{z}$ must = 0; i.e. the neutral axis contains the centre of gravity. Q. E. D. [If the external forces were not all perpendicular to the beam this result would not be obtained, necessarily.]

228. The Shear.—The “total shear,” or simply the “shear,” in the cross-section is the sum of the vertical shearing stresses on the respective dF 's. Call this sum J , and we shall have from the free body in Fig. 222, by putting $\Sigma Y=0$ (Y being vertical)

$$P_r - P_l - J = 0 \therefore J = P_r - P_l \quad . \quad . \quad (3)$$

That is, the shear equals the algebraic sum of the external forces acting on one side (only) of the section considered. This result implies nothing concerning its mode of distribution over the section.

229. The Moment.—By the “Moment of Flexure” or simply the *Moment*, at any cross-section is meant the sum of the moments of the elastic forces of the section, taking the neutral axis as an axis of moments. In this summation the normal stresses appear alone, the shear taking no part, having no lever arm about the neutral axis. Hence, Fig. 222, the *moment of flexure*

$$= \int \left(\frac{z}{e} p dF \right) z = \frac{p}{e} \int dF z^2 = \frac{pI}{e} \quad . \quad . \quad (4)$$

This function, $\int dF z^2$, of the cross-section or plane figure is the quantity called **Moment of Inertia** of a plane figure, § 85. For the free body in Fig. 222, by putting Σ (mom.s about the neutral axis NA)=0, we have then

$$\frac{pI}{e} - P_1 x_1 + P_2 x_2 = 0, \text{ or in general, } \frac{pI}{e} = M \quad . \quad (5)$$

in which M signifies the sum of moments, *about the neutral axis of the section*, of all the forces acting on the free body considered, exclusive of the elastic forces of the exposed section itself.

230. Strength in Flexure.—Eq. (5) is available for solving problems involving the **Strength** of beams and girders, since it contains p , the greatest normal stress per unit of area to be found in the section.

In the cases of the present chapter, where all the external forces are perpendicular to the prism or beam, and have therefore no components parallel to the beam, i.e. to the axis X , it is evident that the normal stresses in any section, as QB Fig. 222, are equivalent to a couple; for the condition $\Sigma X=0$ falls entirely upon them and cannot be true unless the resultant of the tensions is equal, parallel, and opposite to that of the compressions. These two equal and parallel resultants, not being in the same line, form a couple (§ 28), which we may call the *stress-couple*. The moment of this couple is the "moment of flexure" $\frac{pI}{e}$, and it is further evident that the remaining forces in Fig. 222, viz: the shear J and the external forces P_1 and P_2 , are equivalent to a couple of equal and opposite moment to the one formed by the normal stresses.

231. Flexural Stiffness.—The neutral line, or elastic curve, containing the centres of gravity of all the sections, was originally straight; its radius of curvature at any point, as *N*, Fig. 222, during flexure may be introduced as follows. *QB* and *UV'* are two consecutive cross-sections, originally parallel, but now inclined so that the intersection *C*, found by prolonging them sufficiently, is the centre of curvature of the *ds* (put = *dx*) which separates them at *N*, and *CG* = ρ = the radius of curvature of the elastic curve at *N*. From the similar triangles *U'UG* and *GNC* we have $d\lambda : dx :: e : \rho$, in which $d\lambda$ is the elongation, *U'U*, of a portion, originally = *dx*, of the outer fibre. But the relative elongation $\epsilon = \frac{d\lambda}{dx}$ of the latter is, by §184, within the elastic limit, $= \frac{p}{E} \therefore \frac{p}{E} = \frac{e}{\rho}$ and eq. (5) becomes

$$\frac{EI}{\rho} = M \quad . \quad . \quad . \quad . \quad (6)$$

From (6) the radius of curvature can be computed. *E* = the value of $E_i = E_c$, as ascertained from experiments in bending.

To obtain a differential equation of the elastic curve, (6) may be transformed thus, Fig. 223.

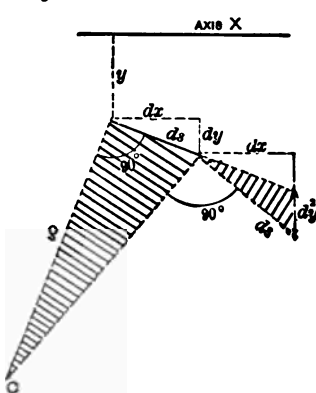

FIG. 223.

flat, consider two consecutive *ds*'s with equal *dx*'s; they may be put = their *dx*'s. Produce the first to intersect the *dy* of the second, thus cutting off the *d'y*, i.e. the difference between two consecutive *dy*'s. Drawing a perpendicular to each *ds* at its left extremity, the centre of curvature *C* is determined by their intersection, and thus the radius of curvature ρ . The two shaded triangles have their small angles

equal, and d^2y is nearly perpendicular to the prolonged ds ; hence, considering them similar, we have

$$\rho : dx :: dx : d^2y \therefore \frac{1}{\rho} = \frac{d^2y}{dx^2}$$

and hence from eq. (6) we have

$$(\text{approx.}) \quad \pm EI \frac{d^2y}{dx^2} = M \quad . \quad . \quad (7)$$

as a differential equation of the elastic curve. From this the equation of the elastic curve may be found, the deflections at different points computed, and an idea thus formed of the stiffness. All beams in the present chapter being *prismatic* and *homogeneous* both E and I are the same (i.e. constant) at all points of the elastic curve. In using (7) the axis X must be taken parallel to the length of the beam before flexure, which must be slight; the minus sign in (7) provides for the case when $d^2y \div dx^2$ is essentially negative.

232. Resilience of Flexure.—If the external forces are made to increase gradually from zero up to certain maximum values, some of them may do work, by reason of their points of application moving through certain distances due to the yielding, or flexure, of the body. If at the beginning and also at the end of this operation the body is at rest, this work has been expended on the elastic resistance of the body, and an equal amount, called the work of resilience (or springing-back), will be restored by the elasticity of the body, if released from the external forces, provided the elastic limit has not been passed. The energy thus temporarily stored is of the potential kind; see §§ 148, 180, 196 and 218.

232a. Distinction Between Simple, and Continuous, Beams (or "Girders").—The external forces acting on a beam consist

generally of the loads and the "reactions" of the supports. If the beam is horizontal and rests on two supports only, the reactions of those supports are easily found by elementary statics [§ 36] alone, without calling into account the theory of flexure, and the beam is said to be a **Simple Beam**, or girder; whereas if it is in contact with more than two supports, being "continuous," therefore, over some of them, it is a **Continuous Girder** (§ 271). The remainder of this chapter will deal only with simple beams.

ELASTIC CURVES.

233. Case I. Horizontal Prismatic Beam, Supported at Both Ends, With a Central Load, Weight of Beam Neglected.—Fig. 224. First considering the whole beam free, we find each



FIG. 224. § 233.

reaction to be $= \frac{1}{2}P$. AOB is the neutral line; required the equation of the portion OB referred to O as an origin, and to the tangent line through O as the axis of X . To do this consider as free the portion mB between any section m on the right of O and the near support, in Fig. 225. The forces holding this free body in equilibrium

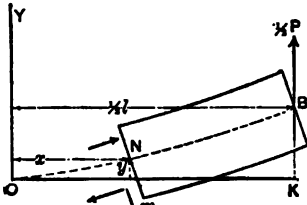

FIG. 225.

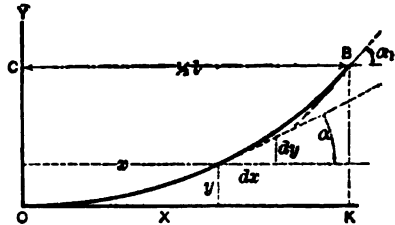

FIG. 226.

are the one external force $\frac{1}{2}P$, and the elastic forces acting on the exposed surface. The latter consist of J , the shear, and the tensions and compressions represented in the figure by their equivalent "stress-couple." Selecting N , the neutral axis of m , as an axis of moments (that J may not appear in the moment equation) and putting Σ (mom) = 0 we have

$$\frac{P}{2} \left(\frac{l}{2} - x \right) - EI \frac{d^2y}{dx^2} = 0 \therefore EI \frac{d^2y}{dx^2} = \frac{P}{2} \left(\frac{l}{2} - x \right) \quad (1)$$

Fig. 226 shows the elastic curve OB in its purely geometrical aspect, much exaggerated. For axes and origin as in figure $d^2y \div dx^2$ is positive.

Eq. (1) gives the second x -derivative of y equal to a function of x . Hence the first x -derivative of y will be equal to the x -anti-derivative of that function, plus a constant, C . (By anti-derivative is meant the converse of derivative, sometimes called integral though not in the sense of summation). Hence from (1) we have (EI being a constant factor remaining undisturbed)

$$EI \frac{dy}{dx} = \frac{P}{2} \left(\frac{l}{2} x - \frac{x^2}{2} \right) + C \quad (2')$$

(2)' is an equation between two variables $dy \div dx$ and x , and holds good for any point between O and B ; $dy \div dx$ denoting the tang. of α , the *slope*, or angle between the tangent line and X . At O the slope is zero, and x also zero; hence at O (2)' becomes

$$EI \times 0 = 0 - 0 + C$$

which enables us to determine the constant C , whose value must be the same at O as for all points of the curve. Hence $C=0$ and (2)' becomes

$$EI \frac{dy}{dx} = \frac{P}{2} \left(\frac{l}{2} x - \frac{x^2}{2} \right) \quad \dots \quad (2)$$

from which the slope, $\tan. a$, (or simply a , in π -measure; since the angle is small) may be found at any point. Thus at B we have $x = \frac{1}{2}l$ and $dy \div dx = a_1$, and

$$\therefore a_1 = \frac{1}{16} \cdot \frac{Pl}{EI}$$

Again, taking the x -anti-derivative of both members of eq. (2) we have

$$EIy = \frac{P}{2} \left(\frac{lx^2}{4} - \frac{x^3}{6} \right) + C' \quad \dots \quad (3')$$

and since at O both x and y are zero, C' is zero. Hence the equation of the elastic curve OB is

$$EIy = \frac{P}{2} \left(\frac{lx^2}{4} - \frac{x^3}{6} \right) \quad \dots \quad (3)$$

To compute the deflection of O from the right line joining A and B in Fig. 224, i.e. $BK = d$, we put $x = \frac{1}{2}l$ in (3), y being then $=d$, and obtain

$$BK = d = \frac{1}{48} \cdot \frac{Pl^3}{EI} \quad \dots \quad (4)$$

Eq. (3) does not admit of negative values for x ; for if the free body of Fig. 225 extended to the left of O , the external forces acting would be P , downward, at O ; and $\frac{1}{2}P$, upward, at B , instead of the latter alone; thus altering the form of eq. (1). From symmetry, however, we know that the curve AO , Fig. 224, is symmetrical with OB about the vertical through O .

233a. Load Suddenly Applied.—Eq. (4) gives the deflection d corresponding to the force or pressure P applied at the middle of the beam, and is seen to be proportional to it. If a load G hangs at rest from the middle of the beam, $P=G$; but if the load G , being initially placed at rest upon the unbent beam, is suddenly released from the external constraint necessary to hold it there, it sinks and deflects the beam, the pressure P actually felt by the beam varying with the deflection as the load sinks. What is the ultimate deflection d_m ? Let P_m = the pressure between the load and the beam at the instant of maximum deflection. The work so far done in bending the beam $=\frac{1}{2}P_m d_m$. The potential energy given up by the load $=Gd_m$, while the initial and final kinetic energies are both nothing.

$$\therefore Gd_m = \frac{1}{2}P_m d_m \quad . \quad . \quad (5)$$

That is, $P_m=2G$. Since at this instant the load is subjected to an upward force of $2G$ and to a downward force of only G (gravity) it immediately begins an upward motion, reaching the point whence the motion began, and thus the oscillation continues. We here suppose the elasticity of the beam unimpaired. This is called the "sudden" application of a load, and produces, as shown above, double the pressure on the beam which it does when gradually applied, and a double deflection. The work done by the beam in raising the weight again is called its resilience.

Similarly, if the weight G is allowed to fall on the middle of the beam from a height h , we shall have

$$G \times (h + d_m), \text{ or approx., } Gh, = \frac{1}{2}P_m d_m;$$

and hence, since (4) gives d_m in terms of P_m ,

$$Gh = \frac{1}{96} \cdot \frac{P_m^2 l^3}{EI}; \text{ or } Gh = \frac{24EI d_m^2}{l^3} \quad . \quad (6)$$

This theory supposes the mass of the beam small compared with the falling weight.

234. Case II. Horizontal Prismatic Beam, Supported at Both Ends, Bearing a Single Eccentric Load. Weight of Beam Neglected.—Fig. 227. The reactions

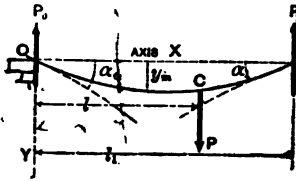

FIG 227.

of the points of support, P_0 and P_1 , are easily found by considering the whole beam free, and putting first $\Sigma(\text{mom.})_O=0$, whence $P_1 = Pl \div l_1$, and then $\Sigma(\text{mom.})_B=0$, whence $P_0 = P(l_1 - l) \div l_1$. P_0 and

P_1 will now be treated as known quantities.

The elastic curves OC and CB , though having a common tangent line at C (and hence the same slope α_c), and a common ordinate at C , have separate equations and are both referred to the same origin and axes, as shown in the figure. The slope at O , α_0 , and that at B , α_1 , are unknown constants, to be determined in the progress of the work.

Equation of OC .—Considering as free a portion of the beam extending from B to a section made anywhere on OC , x and y being the co-ordinates of the neutral axis of that section, we conceive the elastic forces put in on the exposed surface, as in the preceding problem, and put $\Sigma(\text{mom. about neutral axis of the section})=0$ which gives (remembering that here $d^2y \div dx^2$ is negative.)

$$EI \frac{d^2y}{dx^2} = P(l-x) - P_1(l_1-x); \quad \dots \quad (1)$$

whence, by taking the x anti-derivatives of both members

$$EI \frac{dy}{dx} = P\left(lx - \frac{x^2}{2}\right) - P_1\left(l_1x - \frac{x^2}{2}\right) + C$$

To find C , write out this equation for the point O , where $dy \div dx = \alpha_0$ and $x=0$, and we have $C = EI\alpha_0$; hence the equation for slope is

$$EI \frac{dy}{dx} = P(lx - \frac{x^2}{2}) - P_1(l_1x - \frac{x^2}{2}) + EI\alpha_0 \quad (2)$$

Again taking the x anti-derivatives, we have from (2)

$$EIy = P(\frac{lx^2}{2} - \frac{x^3}{6}) - P_1(\frac{l_1x^2}{2} - \frac{x^3}{6}) + EI\alpha_0x + (C' = 0) \quad (3)$$

(at O both x and y are $=0 \therefore C' = 0$). In equations (1), (2), and (3) no value of x is to be used < 0 or $> l$, since for points in CB different relations apply, thus

Equation of CB .—Fig. 227. Let the free body extend from B to a section made anywhere on CB . Σ (mom.), as before, $= 0$, gives

$$EI \frac{d^2y}{dx^2} = -P_1(l_1 - x) \quad (4)$$

(*N.B.* In (4), as in (1), $EId^2y \div dx^2$ is written equal to a negative quantity because itself essentially negative; for the curve is concave to the axis X in the first quadrant of the co-ordinate axes.)

From (4) we have in the ordinary way (x -anti-deriv.)

$$EI \frac{dy}{dx} = -P_1(l_1x - \frac{x^2}{2}) + C'' \quad (5')$$

To determine C'' , consider that the curves CB and OC have the same slope ($dy \div dx$) at O where $x = l$; hence put $x = l$ in the right-hand members of (2) and of (5') and equate the results. This gives $C'' = \frac{1}{2}Pl^2 + EI\alpha_0$ and \therefore

$$EI \frac{dy}{dx} = \frac{Pl^2}{2} + EI\alpha_0 - P_1[l_1x - \frac{x^2}{2}] \quad (5)$$

and $\therefore EIy = \frac{Pl^2}{2}x + EI\alpha_0x - P_1[l_1\frac{x^2}{2} - \frac{x^3}{6}] + C''' \quad (6)$

At C , where $x=l$, both curves have the same ordinate; hence, by putting $x=l$ in the right members of (3) and (6) and equating results, we obtain $C''' = -\frac{1}{6}P\ell$. \therefore (6) becomes

$$EIy = \frac{1}{2}P\ell x + EI\alpha_0 x - P_1 \left[\frac{l_1 x^2}{2} - \frac{x^2}{2} \right] - \frac{P\ell}{6} \quad (6)$$

as the Equation of CB, Fig. 227. But α_0 is still an unknown constant, to find which write out (6) for the point B where $x=l$, and $y=0$, whence we obtain

$$\alpha_0 = \frac{1}{6EI l_1} [P\ell - 3P\ell l_1 + 2P_1 l_1^2] \quad (7)$$

α_1 = a similar form, putting P_0 for P_1 , and (l_1-l) for l .

235. Maximum Deflection in Case II.—Fig. 227. The ordinate y_m of the lowest point is thus found. Assuming $l > \frac{1}{2}l_1$, it will occur in the curve OC . Hence put the $dy \div dx$ of that curve, as expressed in equation (2), = 0. Also for α_0 write its value from (7), having put $P_1 = P\ell \div l_1$, and we have

$$P(lx - \frac{x^2}{2}) - P \frac{l}{l_1} (l_1 x - \frac{x^2}{2}) + \frac{1}{6} \frac{P\ell}{l_1} (\ell - 3l_1 + 2l_1^2) = 0$$

$$\text{whence } [x \text{ for max. } y] = \sqrt{\frac{1}{3}l(2l_1 - l)}$$

Now substitute this value of x in (3), also α_0 from (7), and put $P_1 = P\ell \div l_1$, whence

$$\text{Max. Deflec.} = y_{\max} = \frac{1}{6} \cdot \frac{P}{EI l_1} [\ell - 3P\ell l_1 + 2l_1^2] \sqrt{\frac{1}{3}l(2l_1 - l)}.$$

236. Case III. Horizontal Prismatic Beam Supported at Both Ends and Bearing a Uniformly Distributed Load along its Whole Length.—(The weight of the beam itself, if considered,

constitutes a load of this nature.) Let l = the length of the beam and w = the weight, per unit of length, of the loading; then the load coming upon any length x will be $=wx$, and the whole load $=wl$. By hypothesis w is constant. Fig. 228. From symmetry we know that the

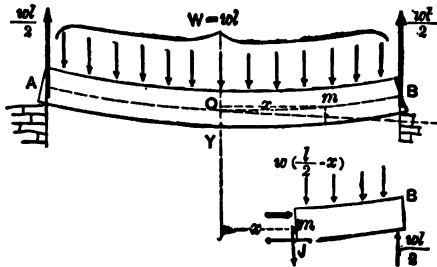

FIG. 228.

reactions at A and B are each $=\frac{1}{2}wl$, that the middle O of the neutral line is its lowest point, and the tangent line at O is horizontal. Conceiving a section made at any point m of the neutral line at a distance x from O , consider as free the portion of beam on the right of m . The forces holding this portion in equilibrium are $\frac{1}{2}wl$, the reaction at B ; the elastic forces of the exposed surface at m , viz.: the tensions and compressions, forming a couple, and J the total shear; and a portion of the load, $w(\frac{1}{2}l-x)$. The sum of the moments of these latter forces about the neutral axis of m , is the same as that of their resultant; (i.e., their sum, since they are parallel), and this resultant acts in the middle of the length $\frac{1}{2}l-x$. Hence the sum of these moments $=w(\frac{1}{2}l-x)\frac{1}{2}(\frac{1}{2}l-x)$. Now putting Σ (mom. about neutral axis of m) $=0$ for this free body, we have

$$EI \frac{d^2y}{dx^2} = \frac{1}{2}wl(\frac{1}{2}l-x) - \frac{1}{2}w(\frac{1}{2}l-x)^2;$$

$$\text{i.e., } EI \frac{d^2y}{dx^2} = \frac{1}{2}w(\frac{1}{4}l^2 - x^2) \quad . \quad . \quad (1)$$

Taking the x -anti-derivative of both sides of (1),

$$EI \frac{dy}{dx} = \frac{1}{2} w (\frac{1}{4} l^2 x - \frac{1}{3} x^3) + (C=0) \tag{2}$$

as the equation of slope. (The constant is =0 since at O both $dy \div dx$ and x are =0.) From (2),

$$EIy = \frac{w}{2} (\frac{1}{8} l^2 x^2 - \frac{1}{12} x^4) + [C'=0] \tag{3}$$

which is the equation of the elastic curve; throughout, i.e., it admits any value of x from $x = +\frac{1}{2}l$ to $x = -\frac{1}{2}l$. This is an equation of the fourth degree, one degree higher than those for the Curves of Cases I and II, where there were no distributed loads. If w were not constant, but proportional to the ordinates of an inclined right line, eq. (3) would be of the fifth degree; if w were proportional to the vertical ordinates of a parabola with axis vertical, (3) would be of the sixth degree; and so on.

By putting $x = \frac{1}{2}l$ in (3) we have the deflection of O below the horizontal through A and B , viz.: (with $W =$ total load = wl)

$$d = \frac{5}{384} \cdot \frac{wl^4}{EI} = \frac{5}{384} \cdot \frac{Wl^3}{EI} \tag{4}$$

237. Case IV. Cantilevers.—A horizontal beam whose only support consists in one end being built in a wall, as in

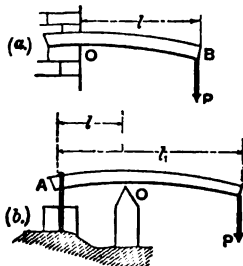

FIG. 229.

Fig. 229(a), or supported as in Fig. 229(b) is sometimes called a cantilever. Let the student prove that in Fig. 229(a) with a single end load P , the deflection of B below the tangent at O is $d = \frac{1}{3} Pl^3 \div EI$; the same statement applies to Fig. 229(b), but the tangent at O is not horizontal if the beam was originally so. It can also be proved that the slope at B , Fig.

229(a) (from the tangent at O) is

$$a_1 = \frac{Pl^2}{2EI}$$

The greatest deflection of the elastic curve from the right line joining AB , in Fig. 229(b), is evidently given by the equation for y max. in § 235, by writing, instead of P of that equation, the reaction at O in Fig. 229(b). This assumes that the max. deflection occurs between A and O . If it occurs between O and B put $(l_1 - l)$ for l .

If in Fig. 229(a) the loading is uniformly distributed along the beam at the rate of w pounds per linear unit, the student may also prove that the deflection of B below the tangent at O is

$$d = \frac{1}{8}wl^4 \div EI = \frac{1}{8} \frac{Wl^4}{EI}$$

238. Case V. Horizontal Prismatic Beam Bearing Equal Terminal Loads and Supported Symmetrically at Two Points.—Fig. 231. Weight of beam neglected. In the preceding cases we have made use of the approximate form $EI d^2y \div dx^2$ in determining the forms of elastic curves. In the present

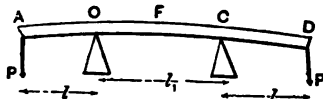

FIG. 231.

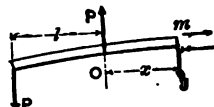

FIG. 232.

case the elastic curve from O to C is more directly dealt with by employing the more exact expression $EI \div \rho$ (see § 231) for the moment of the stress-couple in any section. The reactions at O and C are each $= P$, from symmetry. Considering free a portion of the beam extending from A to any section m between O and C (Fig. 232) we have, by putting Σ (mom. about neutral axis of m) $= 0$,

$$P(l+x) - \frac{EI}{\rho} - Px = 0 \therefore \rho = \frac{EI}{Pl}$$

That is, the radius of curvature is the same at all points of OC ; in other words OC is the *arc of a circle* with the above radius. The upward deflection of F from the right line joining O and C can easily be computed from a knowledge of this fact. This is left to the student as also the value of the slope of the tangent line at O (and C). The deflection of D from the tangent at $C = \frac{1}{2}Pl^2 \div EI$, as in Fig. 229(a).

SAFE LOADS IN FLEXURE.

239. **Maximum Moment.**—As we examine the different sections of a given beam under a given loading we find different values of p , the normal stress per unit of area in the outer element, as obtained from eq. (5) § 229, viz:

$$\frac{pI}{e} = M. \quad . \quad . \quad . \quad . \quad (1)$$

in which I is the "Moment of Inertia" (§ 85) of the plane figure formed by the section, about its neutral axis, e the distance of the most distant (or outer) fibre from the neutral axis, and M the sum of the moments, about this neutral axis, of all the forces acting on the free body of which the section in question is one end, exclusive of the stresses on the exposed surface of that section. In other words M is the sum of the moments of the forces which balance the stresses of the section, these moments being taken about the neutral axis of the section under examination.

For the prismatic beams of this chapter e and I are the same at all sections, hence p varies with M and becomes a maximum when M is a maximum. In any given case the location of the "*dangerous section*," or section of maximum M , and the amount of that maximum value may be determined by inspection and trial, this being the only method (except by graphics) if the external forces are detached.

If, however, the loading is continuous according to a definite algebraic law the calculus may often be applied, taking care to treat separately each portion of the beam between two consecutive reactions of supports, or detached loads.

As a graphical representation of the values of M along the beam in any given case, these values may be conceived laid off as vertical ordinates (according to some definite scale, e.g. so many inch-lbs. of moment to the linear inch of paper) from a horizontal axis just below the beam. If the upper fibres are in compression in any portion of the beam, so that that portion is convex downwards, these ordinates will be laid off below the axis, and vice versâ; for it is evident that at a section where $M=0$, p also $=0$, i.e., the character of the normal stress in the outermost fibre changes (from tension to compression, or vice versâ) when M changes sign. It is also evident from eq. (6) § 231 that the radius of curvature changes sign, and consequently the curvature is reversed, when M changes sign. These moment ordinates form a **Moment Diagram**, and the extremities a **Moment Curve**.

The maximum moment, M_m , being found, in terms of the loads and reactions, we must make the p of the "dangerous section," where $M=M_m$, equal to a safe value R' , and thus may write

$$\frac{R' I}{e} = M_m \quad . \quad . \quad . \quad . \quad (2)$$

Eq. (2) is available for finding any one unknown quantity, whether it be a load, span, or some one dimension of the beam, and is concerned only with the **Strength**, and not with the stiffness of the beam. If it is satisfied in any given case, the normal stress on all elements in all sections is known to be $=$ or $< R'$, and the design is therefore safe in that one respect.

As to danger arising from the shearing stresses in any

section, the consideration of the latter will be taken up in a subsequent chapter and will be found to be necessary only in beams composed of a thin web uniting two flanges. The *total shear*, however, denoted by J , bears to the moment M , an important relation of great service in determining M_m . This relation, therefore, is presented in the next article.

240. The Shear is the First x -Derivative of the Moment.—

Fig. 233. (x is the distance of any section, measured parallel to the beam from an arbitrary origin). Consider as free a vertical slice of the beam included between any two consecutive vertical sections whose distance apart is dx . The forces acting are the elastic forces of the two internal surfaces now laid bare, and, possibly, a portion, $w dx$, of the loading, which at this

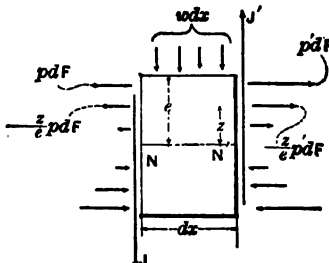

FIG. 233.

part of the beam has some intensity $=w$ lbs. per running linear unit. Putting $\Sigma(\text{mom. about axis } N')=0$ we have (noting that since the tensions and compressions of section N form a couple, the sum of their moments about N' is just the same as about N .)

Putting $\Sigma(\text{mom. about axis } N')=0$ we have (noting that since the tensions and compressions of section N form a couple, the sum of their moments about N' is just the same as about N .)

$$\frac{pI}{e} - \frac{p'I}{e} + Jdx + w dx \cdot \frac{dx}{2} = 0$$

But $\frac{pI}{e} = M$, the Moment of the left hand section, $\frac{p'I}{e} = M'$,

that of the right; whence we may write, after dividing through by dx and transposing,

$$\frac{M' - M}{dx} = J + w \frac{dx}{2} \quad \text{i.e.,} \quad \frac{dM}{dx} = J; \quad (3)$$

for $w \frac{dx}{2}$ vanishes when added to the finite J , and $M' - M = dM =$ increment of the moment corresponding to the increment, dx , of x . This proves the theorem.

Now the value of x which renders M a maximum or minimum would be obtained by putting the derivative $dM \div dx =$ zero; hence we may state as a

Corollary.—At sections where the moment is a maximum or minimum the shear is zero.

The shear J at any section is easily determined by considering free the portion of beam from the section to either end of the beam and putting $\Sigma(\text{vertical components})=0$.

In this article the words maximum and minimum are used in the same sense as in calculus; i.e., graphically, they are the ordinates of the moment curve at points where the *tangent line is horizontal*. If the moment curve be reduced to a straight line, or a series of straight lines, it has no maximum or minimum in the strict sense just stated; nevertheless the relation is still practically borne out by the fact that at the sections of greatest and least ordinates in the moment diagram the shear changes sign suddenly. This is best shown by drawing a *shear diagram*, whose ordinates are laid off vertically from a horizontal axis and under the respective sections of the beam. They will be laid off upward or downward according as J is found to be upward or downward, when the free body considered extends from the section toward the right.

In these diagrams the moment ordinates are set off on an arbitrary scale of so many inch-pounds, or foot-pounds, to the linear inch of paper; the shears being simply pounds, or some other unit of *force*, on a scale of so many pounds to the inch of paper. The scale on which the beam is drawn is so many feet, or inches, to the inch of paper.

241. Safe Load at the Middle of a Prismatic Beam Supported at the Ends.—Fig. 234. The reaction at each support is $\frac{1}{2}P$. Make a section n at any distance $x < \frac{l}{4}$ from B . Consider the portion nB free, putting in the proper elastic and external forces. The weight of beam is neglected. From $\Sigma(\text{mom. about } n)=0$ we have

$$\frac{pI}{e} = \frac{P}{2}x; \text{ i.e., } M = \frac{1}{2}Px$$

Evidently M is proportional to x , and the ordinates representing it will therefore be limited by the straight line

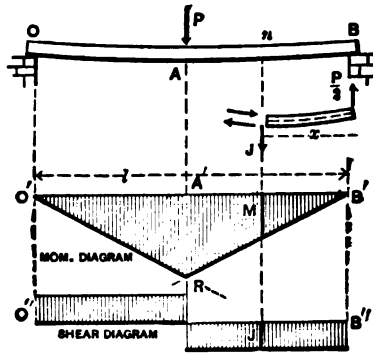

FIG. 284.

$B'R$, forming a triangle $B'RA'$. From symmetry, another triangle $O'RA'$ forms the other half of the moment diagram. From inspection, the maximum M is seen to be in the middle where $x = \frac{1}{2}l$, and hence

$$(M \text{ max.}) = M_m = \frac{1}{4}Pl \quad . \quad . \quad . \quad (1)$$

Again by putting $\Sigma(\text{vert. comps.}) = 0$, for the free body nB we have

$$J = \frac{P}{2}$$

and must point downward since $\frac{P}{2}$ points upward. Hence the shear is constant and $= \frac{1}{2}P$ at any section in the right hand half. If n be taken in the left half we would have, nB being free, from $\Sigma(\text{vert. com.}) = 0$,

$$J = P - \frac{1}{2}P = \frac{1}{2}P$$

the same numerical value as before; but J must point upward, since $\frac{P}{2}$ at B and J at n must balance the downward P at A . At A , then, the shear changes sign suddenly, that is, passes through *the value zero*; also at A , M is a *maximum*, thus illustrating the statement in § 240. Notice the shear diagram in Fig. 234.

To find the safe load in this case we write the maximum value of the normal stress, $p, = R'$, a safe value, (see table in a subsequent article) and solve the equation for P . But the maximum value of p is in the outer fibre at A , since M for that section is a maximum. Hence

$$\frac{R'I}{e} = \frac{1}{4}Pl \quad (2)$$

is the equation for safe loading in this case, so far as the normal stresses in any section are concerned.

EXAMPLE.—If the beam is of wood and has a rectangular section with width $b = 2$ in., height $h = 4$ in., while its length $l = 10$ ft., required the safe load, if the greatest normal stress is limited to 1,000 lbs. per sq. in. Use the pound and inch. From § 90 $I = \frac{1}{12}bh^3 = \frac{1}{12} \times 2 \times 64 = 10.66$ biquad. inches, while $e = \frac{h}{2} = 2$ in.

$$\therefore P = \frac{4R'I}{le} = \frac{4 \times 1,000 \times 10.66}{120 \times 2} = 177.7 \text{ lbs.}$$

242. Safe Load Uniformly Distributed along a Prismatic Beam Supported at the Ends.—Let the load per lineal unit of the length of beam be $= w$ (this can be made to include the weight of the beam itself). Fig. 235. From symmetry,

each reaction $= \frac{1}{2}wl$. For the free body nO we have, putting $\Sigma(\text{mom. about } n) = 0$,

$$\frac{pI}{e} = \frac{wl}{2}x - (wx) \frac{x}{2} \therefore M = \frac{w}{2}(lx - x^2)$$

which gives M for any section by making x vary from 0 to l . Notice that in this case the law of loading is continuous along the whole length, and that hence the moment curve is continuous for the whole length.

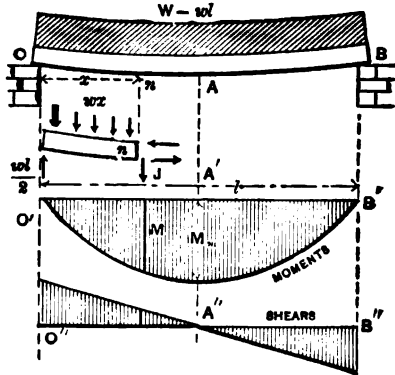

FIG. 235.

To find the shear J , at n , we may either put $\Sigma(\text{vert. comps.})=0$ for the free body, whence $J = \frac{1}{2}wl - wx$, and must therefore be downward for a small value of x ; or, employing § 240, we may write out $dM \div dx$, which gives

$$J = \frac{dM}{dx} = \frac{w}{2}(l - 2x) \quad (1)$$

the same as before. To find the max. M , or M_m , put $J=0$, which gives $x = \frac{1}{2}l$. This indicates a maximum, for when substituted in $d^2M \div dx^2$, i.e., in $-w$, a negative result is obtained. Hence M_m occurs at the middle of the beam and its value is

$$M_m = \frac{1}{8}wl^2; \therefore \frac{R'I}{e} = \frac{1}{8}wl^2 = \frac{1}{8}Wl \quad (2)$$

the equation of safe loading. $W = \text{total load} = wl$.

It can easily be shown that the moment curve is a por-

sion of a parabola, whose vertex is at A'' under the middle of the beam, and axis vertical. The shear diagram consists of ordinates to a single straight line inclined to its axis and crossing it, i.e., giving a zero shear, under the middle of the beam, where we find the max. M .

If a frictionless dove-tail joint with vertical faces were introduced at any locality in the beam and thus divided the beam into two parts, the presence of J would be made manifest by the downward slipping of the left hand part on the right hand part if the joint were on the right of the middle, and vice versâ if it were on the left of the middle. This shows why the ordinates in the two halves of the shear diagram have opposite signs. The greatest shear is close to either support and is $J_m = \frac{1}{2}wl$.

243. Prismatic Beam Supported at its Extremities and Loaded in any Manner. Equation for Safe Loading.—Fig. 236. Given

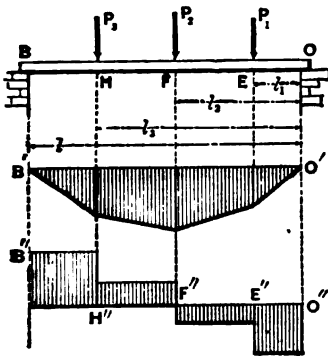

FIG. 236.

the loads $P_1, P_2,$ and $P_3,$ whose distances from the right support are $l_1, l_2,$ and $l_3;$ required the equation for safe loading; i.e., find M_m and write it = $R'I \div e.$

If the moment curve were continuous, i.e., if M were a continuous function of x from end to end of the beam, we could easily find M_m by making $dM \div dx = 0,$ i.e., $J = 0,$ and substitute the resulting value of x in the expression for $M.$ But in the present case of detached loads, J is not zero, necessarily, at any section of the beam. Still there is some one section where it changes sign, i.e., passes suddenly through the value zero, and this will be the section of greatest moment (though not a maximum in the strict sense used in calculus). By considering any portion n as free, J is found equal to the Reaction at O Diminished by the Loads Occuring Between n and $O.$ The reaction at B is

$$P_B = (P_1 l_1 + P_2 l_2 + P_3 l_3) \div l$$

obtained by treating the whole beam as free (in which case no elastic forces come into play) and putting $\Sigma(\text{mom. about } O) = 0$; while that at $O, = P_0 = P_1 + P_2 + P_3 - P_B$

If n is taken anywhere between O and $E, J = P_0$

“ “ “ “ E “ $F, J = P_0 - P_1$

“ “ “ “ F “ $H, J = P_0 - P_1 - P_2$

“ “ “ “ H “ $B, J = P_0 - P_1 - P_2 - P_3$

This last value of J also = the reaction at the other support, B . Accordingly, the shear diagram is seen to consist of a number of horizontal steps. The relation $J = dM \div dx$ is such that the *slope* of the moment curve is proportional to the *ordinate* of the shear diagram, and that for a sudden change in the *slope* of the moment curve there is a sudden change in the shear *ordinate*. Hence in the present instance, J being constant between any two consecutive loads, the moment curve reduces to a straight line between the same loads, this line having a different inclination under each of the portions into which the beam is divided by the loads. Under each load the *slope* of the moment curve and the *ordinate* of the shear diagram change suddenly. In Fig. 236 the shear passes through the value zero, i.e., changes sign, at F ; or algebraically we are supposed to find that $P_0 - P_1$ is + while $P_0 - P_1 - P_2$ is -, in the present case. Considering FO , then, as free, we find M_m to be

$M_m = P_0 l_2 - P_1 (l_2 - l_1)$ and the equation for safe loading is

$$\frac{R'I}{e} = P_0 l_2 - P_1 (l_2 - l_1) \quad (1)$$

(i.e., if the max. M is at F). It is also evident that the greatest shear is equal to the reaction at one or the other support, whichever is the greater, and that the moment at either support is zero.

The student should not confuse the moment curve, which

is entirely imaginary, with the neutral line (or elastic curve) of the beam itself. The greatest moment is not necessarily at the section of maximum deflection of the neutral line (or elastic curve).

For the case in Fig. 236 we may therefore state that the max. moment, and consequently the greatest tension or compression in the outer fibre, will be found in the section under that load for which the sum of the loads (including this load itself) between it and either support first equals or exceeds the reaction of that support. The amount of this moment is then obtained by treating as free either of the two portions of the beam into which this section divides the beam.

244. Numerical Example of the Preceding Article.—Fig. 237. Given P_1, P_2, P_3 , equal to $\frac{1}{2}$ ton, 1 ton, and 4 tons, re-

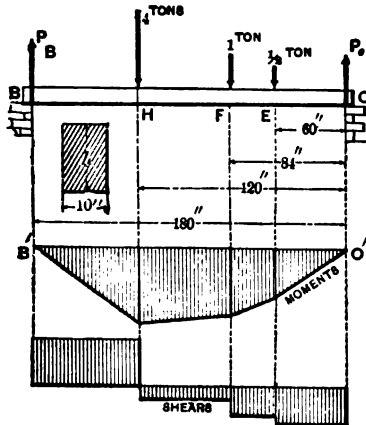

FIG. 237.

spectively ; $l_1=5$ feet, $l_2=7$ feet, and $l_3=10$ feet ; while the total length is 15 feet. The beam is of timber, of rectangular cross-section, the horizontal width being $b=10$ inches, and the value of R' (greatest safe normal stress) = $\frac{1}{2}$ ton per sq. inch, or 1,000 lbs. per sq. inch.

Required the proper depth h for the beam, for safe loading.

Solution.—Adopting a definite system of units, viz., the *inch-ton-second* system, we must reduce all distances such as l , etc., to inches, express all forces in tons, write $R' = \frac{1}{2}$ (tons per sq. inch), and *interpret all results by the same system.* Moments will be in inch-tons, and shears in tons. [N. B. In problems involving the strength of materials the inch is more convenient as a linear unit than the foot, since any stress expressed in lbs., or tons, per sq. inch, is numerically 144 times as small as if referred to the square foot.]

Making the whole beam free, we have from moms. about O , $P_B = \frac{1}{180} [\frac{1}{2} \times 60 + 1 \times 84 + 4 \times 120] = 3.3$ tons $\therefore P_0 = 5.5 - 3.3 = 2.2$ tons.

The shear anywhere between O and E is $J = P_0 = 2.2$ tons.
 “ “ “ “ E and F is $J = 2.2 - \frac{1}{2} = 1.7$ tons.

The shear anywhere between F and H is $J = 2.2 - \frac{1}{2} - 1 = 0.7$ tons.

The shear anywhere between H and B is $J = 2.2 - \frac{1}{2} - 1 - 4 = -3.3$ tons.

Since the shear changes sign on passing H , \therefore the max. moment is at H ; whence making HO free, we have M at $H = M_m = 2.2 \times 120 - \frac{1}{2} \times 60 - 1 \times 36 = 198$ inch-tons.

For safety M_m must = $\frac{R'I}{e}$, in which $R' = \frac{1}{2}$ ton per sq. inch, $e = \frac{1}{2}h = \frac{1}{2}$ of unknown depth of beam, and I , §90, = $\frac{1}{12} bh^3$, with $b = 10$ inches
 $\therefore \frac{1}{12} \cdot \frac{1}{2} \cdot \frac{1}{2} \times 10h^3 = 198$; or $h^3 = 237.6 \therefore h = 15.4$ inches.

245. Comparative Strength of Rectangular Beams.—For such a beam, under a given loading, the equation for safe loading is

$$\frac{R'I}{e} = M_m \text{ i. e. } \frac{1}{2} R' bh^2 = M_m \dots (1)$$

whence the following is evident, (since for the same length, mode of support, and distribution of load, M_m is proportional to the safe loading.)

For rectangular prismatic beams of the same length, same material, same mode of support and same arrangement of load :

(1) The safe load is proportional to the width of beams having the same depth (h).

(2) The safe load is proportional to the square of the depth of beams having the same width (b).

(3) The safe load is proportional to the depth of beams having the *same volume* (i. e. the same bh).

(It is understood that the sides of the section are horizontal and vertical respectively and that the material is homogeneous.)

246. Comparative Stiffness of Rectangular Beams.—Taking the deflection under the same loading as an inverse measure of the stiffness, and noting that in §§ 233, 235, and 236, this deflection is inversely proportional to $I = \frac{1}{12} bh^3 =$ the “moment of inertia” of the section about its neutral axis, we may state that :

For rectangular prismatic beams of the same length, same material, same mode of support, and *same loading* :

(1) The stiffness is proportional to the width for beams of the same depth.

(2) The stiffness is proportional to the cube of the height for beams of the same width (b).

(3) The stiffness is proportional to the square of the depth for beams of equal volume (bhl).

(4) If the length alone vary, the stiffness is inversely proportional to the cube of the length.

247. Table of Moments of Inertia.—These are here recapitulated for the simpler cases, and also the values of e , the distance of the outermost fibre from the axis.

Since the stiffness varies as I (other things being equal),

while the strength varies as $I+e$, it is evident that a square beam has the same stiffness in any position (§89), while its strength is greatest with one side horizontal, for then e is smallest, being $=\frac{1}{2}b$.

Since for any cross-section $I = \int dF z^2$, in which z = the distance of any element, dF , of area from the neutral axis, a beam is made both stiffer and stronger by throwing most of its material into two flanges united by a vertical web, thus forming a so-called "I-beam" of an I shape. But not without limit, for the web must be thick enough to cause the flanges to act together as a solid of continuous substance, and, if too high, is liable to buckle sideways, thus requiring lateral stiffening. These points will be treated later.

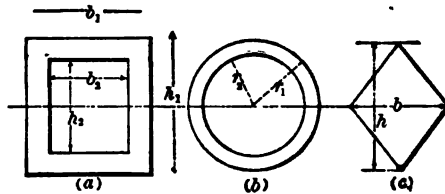
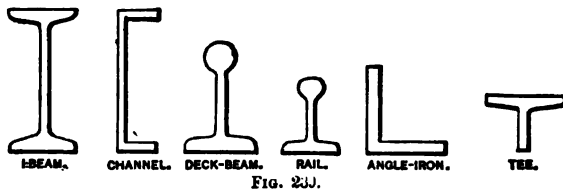

FIG. 238.

SECTION.	I	e
Rectangle, width = b , depth = h (vertical)	$\frac{1}{12} bh^3$	$\frac{1}{2} h$
Hollow Rectangle, symmet. about neutral axis. See Fig. 238 (a)	$\frac{1}{12} [b_1 h_1^3 - b_2 h_2^3]$	$\frac{1}{2} h_1$
Triangle, width = b , height = h , neutral axis parallel to base (horizontal).	$\frac{1}{36} bh^3$	$\frac{1}{3} h$
Circle of radius r	$\frac{1}{4} \pi r^4$	r
Ring of concentric circles. Fig. 238 (b)	$\frac{1}{4} \pi (r_1^4 - r_2^4)$	r_1
Rhombus; Fig. 238 (c) h = diagonal which is vertical.	$\frac{1}{48} bh^3$	$\frac{1}{4} h$
Square with side b vertical.	$\frac{1}{12} b^4$	$\frac{1}{2} b$
" " " b at 45° with horiz.	$\frac{1}{12} b^4$	$\frac{1}{4} b \sqrt{2}$

248. Moment of Inertia of I-beams, Box-girders, Etc.—In common with other large companies, the N. J. Steel and

Iron Co. of Trenton, N. J. (Cooper, Hewitt & Co.) manufacture prismatic rolled beams of wrought-iron variously called *I*-beams, deck-beams, rails, and "shape iron," (including channels, angles, tees, etc., according to the form of section.) See fig. 239 for these forms. The company



publishes a pocket-book giving tables of quantities relating to the strength and stiffness of beams, such as the safe loads for various spans, moments of inertia of their sections in various positions, etc., etc. The moments of inertia of *I*-beams and deck-beams are computed according to §§ 92 and 93, with the inch as linear unit. The *I*-beams range from 4 in. to 20 inches deep, the deck-beams being about 7 and 8 in. deep.

For beams of still greater stiffness and strength combinations of plates, channels, angles, etc., are riveted together, forming "built-beams," or "plate girders." The proper design for the riveting of such beams will be examined later. For the present the parts are assumed to act together as a continuous mass: For example, Fig. 240 shows a "box-girder," formed of two "channels" and two plates riveted together. If the axis of symmetry, *N*,

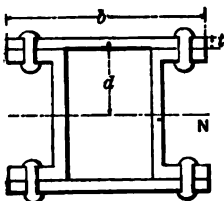

FIG. 240.

is to be horizontal it becomes the neutral axis. Let *C* = the moment of inertia of one channel (as given in the pocket-book mentioned) about the axis *N* perpendicular to the web of the channel. Then the total *moment of inertia* of the combination is (nearly)

$$I_N = 2C + 2bt^3 - 4d't'(d - \frac{1}{2}t)^2 \quad . \quad . \quad (1)$$

In (1), b , t , and d are the distances given in Fig. 240 (d extends to the middle of plate) while d' and t' are the length and width of a rivet, the former from head to head (i.e., d' and t' are the dimensions of a rivet-hole).

For example, a box-girder of wrought-iron is formed of two 15-inch channels and two plates 10 inches wide and 1 inch thick, the rivet holes $\frac{3}{4}$ in. wide and $1\frac{3}{4}$ in. long. That is, $b=10$; $t=1$; $d=8$; $t'=\frac{3}{4}$; and $d'=1\frac{3}{4}$ inches. Also from the pocket-book we find that for the channel in question, $C=376$ biquadratic inches. Hence, eq. (1)

$$I_N = 752 + 2 \times 10 \times 1 \times 64 - 4 \times \frac{1}{4} \times \frac{3}{4} (8 - \frac{1}{2})^2 = 1737 \text{ biquadr.in.}$$

Also, since in this instance $e = 8\frac{1}{2}$ inches, and 12000 lbs. per sq. inch (or 6 tons per sq. in.) is the value for R' (=greatest safe normal stress on the outer element of any cross-section) used by the Trenton Co. (for wrought iron),

$$\text{we have } \frac{R'I}{e} = \frac{12000 \times 1737}{8.5} = 2451700 \text{ inch-lbs.}$$

That is, the box-girder can safely bear a maximum moment, $M_m = 2451700$ inch-lbs. = 1225.8 inch-tons, as far as the normal stresses in any section are concerned. (Proper provision for the shearing stresses in the section, and in the rivets, will be considered later).

249. Strength of Cantilevers.—In Fig. 241 with a single

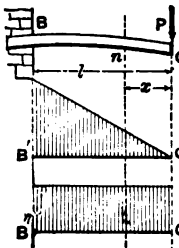

FIG. 241.

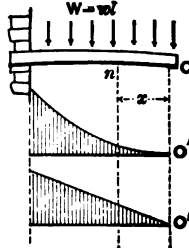

FIG. 242.

concentrated load P at the projecting extremity, we easily find the moment at n to be $M = Px$, and the max. moment to occur at the section next the wall, its value being $M_m = Pl$.

The shear, J , is constant, and $= P$ at all sections.

The moment and shear diagrams are drawn in accordance with these results.

If the load $W = wl$ is uniformly distributed on the cantilever, as in fig. 242, by making nO free we have, putting $\Sigma(\text{mom. about } n) = 0$,

$$\frac{pI}{e} = wx \cdot \frac{x}{2} \therefore M = \frac{1}{2}wx^2 \therefore M_m = \frac{1}{2}wl^2 = \frac{1}{2}WL.$$

Hence the moment curve is a parabola, whose vertex is at O' and axis vertical. Putting $\Sigma(\text{vert. comps.}) = 0$ we obtain $J = wx$. Hence the shear diagram is a triangle, and the max. $J = wl = W$.

250. Résumé of the Four Simple Cases.—The following table shows the values of the deflections under an arbitrary load P , or W , (within elastic limit), and of the safe load;

	Cantilevers.		Beams with two end supports.	
	With one end load P Fig. 241	With unif. load $W = wl$ Fig. 242	Load P in middle Fig. 234	Unif. load $W = wl$ Fig. 235
Deflection	$\frac{1}{8} \cdot \frac{Pl^3}{EI}$	$\frac{1}{8} \cdot \frac{Wl^3}{EI}$	$\frac{1}{48} \cdot \frac{Pl^3}{EI}$	$\frac{5}{384} \cdot \frac{Wl^3}{EI}$
{ Safe load (from $\frac{R'I}{e}$ } = M_m)	$\frac{R'I}{le}$	$\frac{2R'I}{le}$	$\frac{4R'I}{le}$	$\frac{8R'I}{le}$
Relative strength	1	2	4	8
{ Relative stiffness } under same load	1	$\frac{1}{8}$	16	$\frac{128}{5}$
{ Relative stiffness } under safe load	1	$\frac{1}{8}$	4	$\frac{16}{5}$
{ Max. shear = J_m , (and } location,	P , (at wall)	W , (at wall)	$\frac{1}{2}P$, (at supp.)	$\frac{1}{2}W$, (at supp.)

also the relative strength, the relative stiffness (under the same load), and the relative stiffness under the safe load, for the same beam.

The max. shear will be used to determine the proper web-thickness for I -beams and "built-girders." The student should carefully study the foregoing table, noting especially the relative strength, stiffness, and stiffness under safe load, of the same beam.

Thus, a beam with two end supports will bear a double

load, if uniformly distributed instead of concentrated in the middle, but will deflect $\frac{1}{4}$ more; whereas with a given load uniformly distributed the deflection would be only $\frac{5}{8}$ of that caused by the same load in the middle, provided the elastic limit is not surpassed in either case.

251. R' , etc. For Various Materials.—The formula $\frac{p_m I}{e} = M_m$, from which in any given case of flexure we can compute the value of p_m , the greatest normal stress in any outer element, provided all the other quantities are known, holds good theoretically within the elastic limit only. Still, some experimenters have used this formula for the rupture of beams by flexure, calling the value of p_m thus obtained the *Modulus of Rupture*, R . R may be found to differ considerably from both the T or C of § 203 with some materials and forms, being frequently much larger. This might be expected, since even supposing the relative extension or compression (i.e., strain) of the fibres to be proportional to their distances from the neutral axis as the load increases toward rupture, the corresponding stresses, not being proportional to these strains beyond the elastic limit, no longer vary directly as the distances from the neutral axis; and the neutral axis does not pass through the centre of gravity of the section, necessarily.

The following table gives average values for R , R' , R'' , and E for the ordinary materials of construction. E , the modulus of elasticity for use in the formulæ for deflection, is given as computed from experiments in flexure, and is nearly the same as E_t and E_c .

In any example involving R' , e is usually written equal to the distance of the outer fibre from the neutral axis, whether that fibre is to be in tension or compression; since in most materials not only is the tensile equal to the compressive stress for a given strain (relative extension or contraction) but the elastic limit is reached at about the *same strain* both in tension and compression.

TABLE FOR USE IN EXAMPLES IN FLEXURE.

	Timber.	Cast Iron.	Wro't Iron.	Steel.
Max. safe stress in outer fibre — R' (lbs. per sq. inch.)	1,000	6,000 in tens. 12,000 in comp.	12,000	15,000 to 40,000
Stress in outer fibre at Elaa. limit — R'' (lbs. per sq. in.)			17,000* to 35,000	30,000 and upward.
"Modul. of Rupture" — R —lbs. per sq. inch.	4,000 to 20,000	40,000	50,000	120,000
E —Mod. of Elasticity, —lbs. per sq. inch.	1,000,000 to 3,000,000	17,000,000	25,000,000	Hard Steel. 30,000,000

In the case of cast iron, however, (see § 203) the elastic limit is reached in tension with a stress = 9,000 lbs. per sq. inch and a relative extension of $\frac{66}{1000}$ of one per cent., while in compression the stress must be about double to reach the elastic limit, the relative change of form (strain) being also double. Hence with cast iron beams, once largely used but now almost entirely displaced by rolled wrought iron beams, an economy of material was effected by making the outer fibre on the compressed side twice as far from the neutral axis as that on the stretched side. Thus, Fig. 243, cross-sections with unequal flanges were

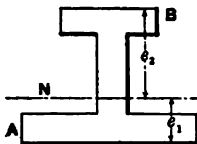

FIG. 243.

used, so proportioned that the centre of gravity was twice as near to the outer fibre in tension as to that in compression, i.e., $e_2 = 2e_1$; in other words more material is placed in tension than in compression. The fibre A being in tension (within elastic limit), that at B , since it is twice as far from the neutral axis and on the other side, is contracted twice as much as A is extended; i.e., is under a compressive strain double the tensile strain at A , but in accordance with the above figures its state of stress is proportionally as much within the elastic limit as that of A .

Steel beams are gradually coming into use, and may ultimately replace those of wrought iron.

* In the tests by U. S. Gov. in 1879 with I-beams, R'' ranged from 25,000 to 38,000, and the elastic limit was reached with less stress in the large than in the smaller beams. Also, for the same beam, R' decreased with larger spans.

The great range of values of R for timber is due not only to the fact that the various kinds of wood differ widely in strength, while the behavior of specimens of any one kind depends somewhat on age, seasoning, etc., but also to the circumstance that the size of the beam under experiment has much to do with the result. The experiments of Prof. Lanza at the Mass. Institute of Technology in 1881 were made on full size lumber (spruce), of dimensions such as are usually taken for floor beams in buildings, and gave much smaller values of R (from 3,200 to 8,700 lbs. per sq. inch) than had previously been obtained. The loading employed was in most cases a concentrated load midway between the two supports.

These low values are probably due to the fact that in large specimens of ordinary lumber the continuity of its substance is more or less broken by cracks, knots, etc., the higher values of most other experimenters having been obtained with small, straight-grained, selected pieces, from one foot to six feet in length.

The value $R' = 12,000$ lbs. per sq. inch* is employed by the N. J. Iron and Steel Co. in computing the safe loads for their rolled wrought iron beams, with the stipulation that the beams (which are high and of narrow width) must be secure against yielding sideways. If such is not the case the ratio of the actual safe load to that computed with $R' = 12,000$ is taken less and less as the span increases. The lateral security referred to may be furnished by the brick arch-filling of a fire-proof floor, or by light lateral bracing with the other beams.

252. Numerical Examples.—EXAMPLE 1.—A square bar of wrought iron, $1\frac{1}{2}$ in. in thickness is bent into a circular arc whose radius is 200 ft., the plane of bending being parallel to the side of the square. Required the greatest normal stress p_m in any outer fibre.

Solution. From §§ 230 and 231 we may write

$$\frac{EI}{\rho} = \frac{pI}{e} \therefore p = eE \div \rho, \text{ i. e., is constant.}$$

* For their soft-steel beams this company uses 16,000 lbs. per sq. inch.

For the units *inch* and *pound* (viz. those of the table in § 251) we have $e = \frac{3}{4}$ in., $\rho = 2,400$ in., and $E = 25,000,000$ lbs. per sq. inch, and \therefore

$$p = p_m = \frac{3}{4} \times 25,000,000 \div 2,400 = 7,812 \text{ lbs. per sq. in.},$$

which is quite safe. At a distance of $\frac{1}{2}$ inch from the neutral axis, the normal stress is $= [\frac{1}{2} \div \frac{3}{4}] p_m = \frac{2}{3} p_m = 5,208$ lbs. per sq. in. (If the force-plane (i.e., plane of bending) were parallel to the *diagonal* of the square, e would $= \frac{1}{2} \times 1.5\sqrt{2}$ inches, giving $p_m = [7,812 \times \sqrt{2}]$ lbs. per sq. in.) § 238 shows an instance where a portion, OC , Fig. 231, is bent in a circular arc.

EXAMPLE 2.—A hollow cylindrical cast-iron pipe of radii $3\frac{1}{2}$ and 4 inches* is supported at its ends and loaded in middle (see Fig. 234). Required the safe load, neglecting the weight of the pipe. From the table in § 250 we have for safety

$$P = 4 \frac{RI}{le}$$

From § 251 we put $R' = 6,000$ lbs. per sq. in.; and from § 247 $I = \frac{\pi}{4}(r_1^4 - r_2^4)$; and with these values, r_2 being $= \frac{7}{2}$, $r_1 = 4$, $e = r_1 = 4$, $\pi = \frac{22}{7}$ and $l = 144$ inches (the inch must be the unit of length since $R' = 6,000$ lbs. per sq. inch) we have

$$P = 4 \times 6,000 \times \frac{1}{4} \cdot \frac{22}{7} (256 - 150) \div [144 \times 4] \therefore P = 3,470 \text{ lbs.}$$

The weight of the beam itself is $G = V\gamma$, (§ 7), i.e.,

$$G = \pi(r_1^2 - r_2^2)l\gamma = \frac{22}{7}(16 - 12\frac{1}{4})144 \times \frac{450}{1,728} = 443 \text{ lbs.}$$

(Notice that γ , here, must be lbs., per *cubic inch*). This weight being a uniformly distributed load is equivalent to half as much, 221 lbs., applied in the middle, as far as the *strength* of the beam is concerned (see § 250), $\therefore P$ must be taken $= 3,249$ lbs. when the weight of the beam is considered.

* And 12 feet in length between supports.

EXAMPLE 3.—A wrought-iron rolled I-beam supported at the ends is to be loaded uniformly Fig. 235, the span being equal to 20 feet. Its cross-section, Fig. 244, has a

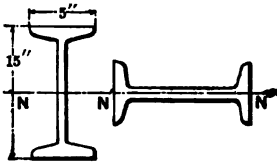

FIG. 244.

depth parallel to the web of 15 inches, a flange width of 5 inches. In the pocket book of the Trenton Co. it is called a 15-inch *light* I-beam, weighing 150 lbs. per yard, with a moment of inertia = 523. biquad. inches about a gravity axis perpendicular to the web (i.e., when the web is vertical, the strongest position) and = 15 biq. in. about a gravity axis parallel to the web (i.e., when the web is placed horizontally).

First placing the web vertically, we have from § 250,

$$W_1 = \text{Safe load, distributed,} = 8 \frac{R' I_1}{l e_1}. \text{ With } R' = 12,000,$$

$I_1 = 523$, $l = 240$ inches, $e_1 = 7\frac{1}{2}$ inches, this gives

$$W_1 = [8 \times 12,000 \times 523] \div [240 \times \frac{15}{2}] = 27,893 \text{ lbs.}$$

But this includes the weight of the beam, $G = 20 \text{ ft.} \times \frac{150}{3} \text{ lbs.} = 1,000 \text{ lbs.}$; hence a distributed load of 26,902 lbs., or 13.45 tons may be placed on the beam (secured against lateral yielding). (The pocket-book referred to gives 13.27 tons as the safe load.)

Secondly, placing the web *horizontal*,

$$W_2 = 8 \frac{R' I_2}{l e_2} = [8 \times 12,000 \times 15] \div [240 \times \frac{5}{2}] = \frac{45}{523} \text{ of } W_1$$

or only about $\frac{1}{12}$ of W_1 .

EXAMPLE 4.—Required the deflection in the first case of Ex. 3. From § 250 the deflection at middle is

$$d_1 = \frac{5}{384} \cdot \frac{W_1 l^3}{EI_1} = \frac{5}{384} \cdot \frac{8R' I_1}{l e_1} \cdot \frac{l^3}{EI_1} = \frac{5}{48} \cdot \frac{R'}{E} \cdot \frac{l^2}{e_1}$$

i.e., $d_1 = \frac{5}{48} \cdot \frac{12,000}{25,000,000} \cdot \frac{(240)^2}{\frac{15}{2}}$; (inch and pound)

$\therefore d_1 = 0.384$ in.

EXAMPLE 5.—A rectangular beam of yellow pine, of width $b=4$ inches, is 20 ft. long, rests on two end supports, and is to carry a load of 1,200 lbs. at the middle; required the proper depth h . From § 250

$$P = 4 \frac{R'I}{le} = 4 \frac{R' bh^2}{l \cdot 12} \cdot \frac{1}{\frac{1}{2}h}$$

$\therefore h^2 = 6Pl \div 4R'b$. For variety, use the *inch* and *ton*. For this system of units $P=0.60$ tons, $R'=0.50$ tons per sq. in., $l=240$ inches and $b=4$ inches.

$\therefore h^2 = (6 \times 0.6 \times 240) \div (4 \times 0.5 \times 4) = 108$ sq. in. $\therefore h = 10.4$ in.

EXAMPLE 6.—Suppose the depth in Ex. 5 to be determined by the condition that the deflection shall be $= \frac{1}{500}$ of the span or length. We should then have from § 250

$$d = \frac{1}{500} \quad l = \frac{1}{48} \frac{Pl^3}{EI}$$

Using the inch and ton, with $E=1,200,000$ lbs. per sq. in., which = 600 tons per sq. inch, and $I = \frac{1}{12}bh^3$, we have

$$h^3 = \frac{500 \times 0.60 \times 240 \times 240 \times 12}{48 \times 600 \times 4} = 1,800 \therefore h = 12.2$$
 in.

As this is > 10.4 the load would be safe, as well.

EXAMPLE 7.—Required the length of a wro't iron pipe supported at its extremities, its internal radius being $2\frac{1}{4}$ in., the external 2.50 in., that the deflection *under its own weight* may equal $\frac{1}{100}$ of the length. 579.6 in. Ans.

EXAMPLE 8.—Fig. 245. The wall is 6 feet high and one foot thick, of common brick work (see § 7) and is to be borne by an I-beam in whose outer fibres no greater normal stress than 8,000 lbs. per sq. inch is allowable. If a number of I-beams is available,

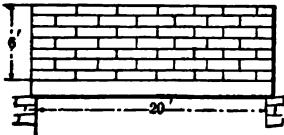

FIG. 245.

ranging in height from 6 in. to 15 in. (by whole inches), which one shall be chosen in the present instance, if their cross-sections are Similar Figures, the moment of inertia of the 15-inch beam being 800 biquad. inches?

The 12-inch beam. Ans.

SHEARING STRESSES IN FLEXURE.

253. Shearing Stresses in Surfaces Parallel to the Neutral Surface.—If a pile of boards (see Fig. 246) is used to support a load, the boards being free to slip on each other, it is noticeable that the ends overlap, although the boards

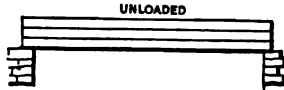

FIG. 246.

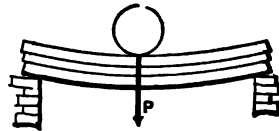

FIG. 247.

are of equal length (now see Fig. 247); i.e., slipping has occurred along the surfaces of contact, the combination being no stronger than the same boards side by side. If, however, they are glued together, piled as in the former figure, the slipping is prevented and the deflection is much less under the same load P . That is, the compound beam is both stronger and stiffer than the pile of loose boards, but the *tendency* to slip still exists and is known as the "shearing stress in surfaces parallel to the neutral surface." Its intensity per unit of area will now be determined by the usual "free-body" method. In Fig. 248 let AN' be a portion, considered free, on the left of any



FIG. 248.

section N' , of a prismatic beam slightly bent under forces in one plane and perpendicular to the beam. The moment equation, about the neutral axis at N' , gives

$$\frac{p'I}{e} = M'; \text{ whence } p' = \frac{M'e}{I} \quad (1)$$

Similarly, with AN as a free body, NN' being $=dx$,

$$\frac{pI}{e} = M; \text{ whence } p = \frac{Me}{I} \quad (2)$$

p and p' are the respective normal stresses in the outer fibre in the transverse sections N and N' respectively.

Now separate the block NN' , lying between these two consecutive sections, as a free body (in Fig. 249). And

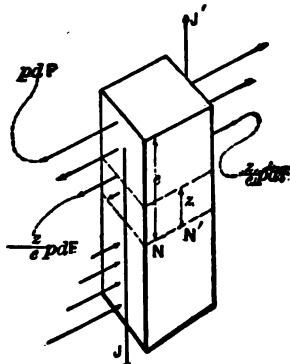

FIG. 249.

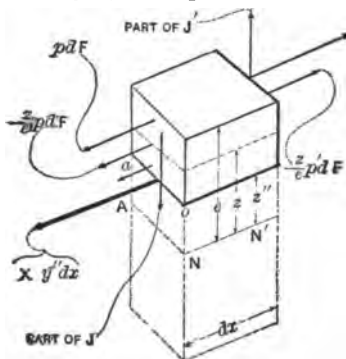

FIG. 250.

furthermore remove a portion of the top of the latter block, the portion lying above a plane passed parallel to the neutral surface and at any distance z'' from that surface. This latter free body is shown in Fig. 250, with the system of forces representing the actions upon it of the portions taken away. The under surface, just laid bare, is a portion of a surface (parallel to the neutral surface) in which the above mentioned slipping, or shearing, tendency exists. The lower portion (of the block NN') which is now removed exerted this

rubbing, or sliding, force on the remainder along the under surface of the latter. Let the unknown intensity of this shearing force be X (per unit of area); then the shearing force on this under surface is $= Xy''dx$, ($y'' = oa$ in figure, being the horizontal width of the beam at this distance z'' from the neutral axis of N) and takes its place with the other forces of the system, which are the normal stresses between $\left[\begin{matrix} z=e \\ z=z'' \end{matrix} \right]$, and portions of J and J' , the respective total vertical shears. (The manner of distribution of J over the vertical section is as yet unknown; see next article.)

Putting Σ (horiz. comps.) = 0 in Fig. 250, we have

$$\int_{z''}^e \frac{z}{e} p' dF - \int_{z''}^e \frac{z}{e} p dF - Xy'' dx = 0$$

$$\therefore Xy'' dx = \frac{p' - p}{e} \int_{z''}^e z dF$$

But from eqs. (1) and (2), $p' - p = (M' - M) \frac{e}{I} = \frac{e}{I} dM$, while from § 240 $dM = Jdx$;

$$\therefore Xy'' dx = \frac{Jdx}{I} \int_{z''}^e z dF \therefore X = \frac{J}{Iy''} \int_{z''}^e z dF \quad \dots \quad (3)$$

as the required intensity *per unit of area* of the shearing force in a surface parallel to the neutral surface and at a distance z'' from it. It is seen to depend on the "shear" J and the moment of inertia I of the *whole* vertical section; upon the horizontal thickness y'' of the beam at the surface in question; and upon the integral $\int_{z''}^e z dF$,

which (from § 23) is the *product of the area of that part of the vertical section extending from the surface in question to the outer fibre, by the distance of the centre of gravity of that part from the neutral surface.*

It now follows, from § 209, that the intensity (per unit area) of the shear on an elementary area of the *vertical cross section* of a bent beam, and this intensity we may call Z , is equal to that X , just found, in the horizontal section which is at the same distance (z'') from the neutral axis.

254. Mode of Distribution of J , the Total Shear, over the Vertical Cross Section.—The intensity of this shear, Z (lbs. per sq. inch, for instance) has just been proved to be

$$Z = X = \frac{J}{Iy''} \int_{z''}^e zdF \tag{4}$$

To illustrate this, required the value of Z two inches above the neutral axis, in a cross section close to the abutment, in Ex. 5, § 252. Fig. 251 shows this section. From it we have for the *shaded portion*, lying above the locality in question, $y'' =$

4 inches, and $\int_{z''=2}^e zdF =$ (area

of shaded portion) \times (distance of its centre of gravity from NA) = (12.8 sq. in.) \times (3.6 in.) = 46.08 cubic inches.

The total shear J = the abutment reaction = 600 lbs., while $I = \frac{1}{12} bh^3 = \frac{1}{12} \times 4 \times (10.4)^3 = 375$ biquad. inches. Both J and I refer to the *whole section*.

$$\therefore Z = \frac{600 \times 46.08}{375 \times 4} = 18.42 \text{ lbs. per sq. in.},$$

quite insignificant. In the neighborhood of the neutral axis, where $z'' = 0$, we have $y'' = 4$ and

$$\int_{z''=0}^e zdF = \int_0^e zdF = 20.8 \times 2.6 = 54.8,$$

where J and I of course are the same as before. Hence for $z'' = 0$

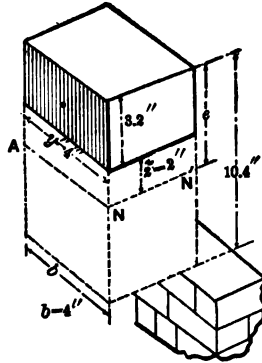

FIG. 251.

$$Z - Z_0 = 21.62 \text{ lbs. per sq. in.}$$

At the outer fibre since $\int_e^e z dF = 0$, z' being $= e$, Z is $= 0$

for a beam of any shape.

For a solid rectangular section like the above, Z and z' bear the same relation to each other as the co-ordinates of the parabola in Fig. 252 (axis horizontal).

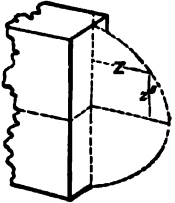

FIG. 252

Since in equation (4) the horizontal thickness, y'' , from side to side of the section of the locality where Z is desired,

occurs in the denominator, and since $\int_{z'}^e z dF$

increases as z' grows *numerically* smaller, the following may be stated, as to the distribution of J , the shear, in any vertical section, viz.:

The intensity (lbs. per sq. in.) of the shear is zero at the outer elements of the section, and for beams of ordinary shapes is greatest where the section crosses the neutral surface. For forms of cross section having thin webs its value may be so great as to require special investigation for safe design.

Denoting by Z_0 the value of Z at the neutral axis, (which $= X_0$ in the neutral surface where it crosses the vertical section in question) and putting the thickness of the substance of the beam $= b_0$ at the neutral axis, we have,

$$Z_0 = X_0 = \frac{J}{I b_0} \times \left\{ \begin{array}{l} \text{area above} \\ \text{neutral axis} \\ \text{(or below)} \end{array} \right\} \times \left\{ \begin{array}{l} \text{the dist. of its cent.} \\ \text{grav. from that axis} \end{array} \right\} \quad (5)$$

255. Values of Z_0 for Special Forms of Cross Section.—From the last equation it is plain that for a prismatic beam the value of Z_0 is proportional to J , the total shear, and hence to the ordinate of the shear diagram for any particular case of loading. The utility of such a diagram, as obtain-

ed in Figs. 234–237 inclusive, is therefore evident, for by locating the greatest shearing stress in the beam it enables us to provide proper relations between the loading and the form and material of the beam to secure safety against rupture by shearing.

The table in § 210 gives safe values which the maximum Z_0 in any case should not exceed. It is only in the case of beams with thin webs (see Figs. 238 and 240) however, that Z_0 is likely to need attention.



FIG. 253.

For a Rectangle we have, Fig. 253, (see eq. 5, §

$$254) b_0 = b, I = \frac{1}{12}bh^3, \text{ and } \int_0^e zdF = \frac{1}{2}bh \cdot \frac{1}{4}h = \frac{1}{8}bh^2$$

$$\therefore Z_0 = X_0 = \frac{3}{2} \frac{J}{b_0 h} \text{ i.e., } = \frac{3}{2} (\text{total shear}) \div (\text{whole area})$$

Hence the greatest intensity of shear in the cross-section is $\frac{3}{2}$ as great per unit of area as if the total shear were uniformly distributed over the section.

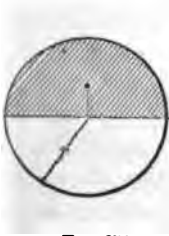

FIG. 254.

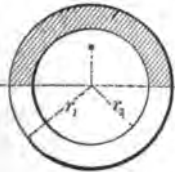

FIG. 255.

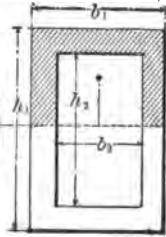

FIG. 256.

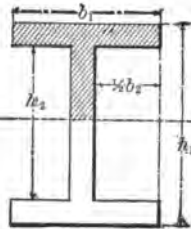

FIG. 257.

For a Solid Circular section Fig. 254

$$Z_0 = \frac{J}{I b_0} \int_0^e zdF = \frac{J}{\frac{1}{4} \pi r^4 \cdot 2r} \cdot \frac{\pi r^2}{2} \cdot \frac{4r}{3\pi} = \frac{4}{3} \cdot \frac{J}{\pi r^3}$$

[See § 26 Prob. 3].

For a Hollow Circular section (concentric circles) Fig. 255, we have similarly,

$$Z_0 = \frac{J}{\frac{1}{4}\pi(r_1^4 - r_2^4)2(r_1 - r_2)} \left[\frac{\pi r_1^2}{2} \cdot \frac{4r_1}{3\pi} - \frac{\pi r_2^2}{2} \cdot \frac{4r_2}{3\pi} \right]$$

$$= \frac{4}{3} \cdot \frac{J(r_1^3 - r_2^3)}{\pi(r_1^4 - r_2^4)(r_1 - r_2)}$$

Applying this formula to Example 2 § 252, we first have as the max. shear $J_m = \frac{1}{2}P = 1,735$ lbs., this being the abutment reaction, and hence (putting $\pi = (22 \div 7)$)

$$Z_0 \text{ max.} = \frac{4 \times 7 \times 1735 [64 - 42.8]}{3 \times 22 [256 - 150] (4 - 3.5)} = 294 \text{ lbs. per sq. in.}$$

which cast iron is abundantly able to withstand in shearing.

For a **Hollow Rectangular Beam**, symmetrical about its neutral surface, Fig. 256 (box girder)

$$Z_0 = \frac{J \frac{1}{8}(b_1 h_1^2 - b_2 h_2^2)}{\frac{1}{12}(b_1 h_1^3 - b_2 h_2^3)(b_1 - b_2)} = \frac{3}{2} \cdot \frac{J [b_1 h_1^2 - b_2 h_2^2]}{[b_1 h_1^3 - b_2 h_2^3] [b_1 - b_2]}$$

The same equation holds good for Fig. 257 (I-beam with square corners) but then b_2 denotes the sum of the widths of the hollow spaces.

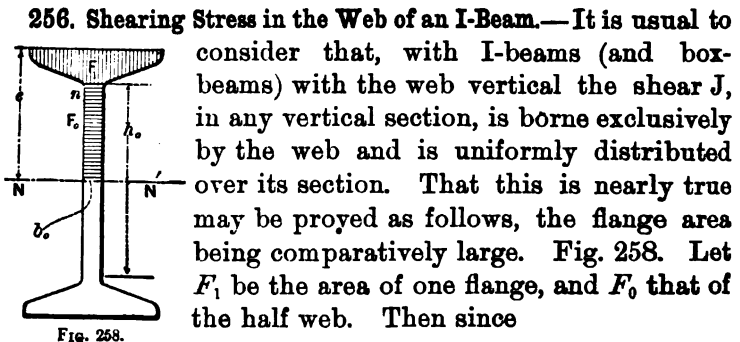

FIG. 258.

$$I = \frac{1}{12} b_0 h_0^3 + 2F_1 \left(\frac{h_0}{2} \right)^2$$

(the last term approximate, $\frac{1}{2} h_0$ being taken for the radius of gyration of F_1), while

$$\int_0^e zdF = F_1 \frac{h_0}{2} + F_0 \frac{h_0}{4}, \quad (\text{the first term approx.}) \text{ we have}$$

$$Z_0 = \frac{J \int_0^e zdF}{I b_0} = \frac{J \frac{1}{4} h_0 (2F_1 + F_0)}{\frac{1}{12} h^3 b_0 (6F_1 + 2F_0)}, \quad \text{which} = \frac{J}{b_0 h_0},$$

if we write $(2F_1 + F_0) \div (6F_1 + 2F_0) = \frac{1}{3}$. But $b_0 h_0$ is the area of the whole web, \therefore the shear per unit area at the neutral axis is nearly the same as if J were uniformly distributed over the web. E. g., with $F_1 = 2$ sq. in., and $F_0 = 1$ sq. in. we obtain $Z_0 = 1.07 (J + b_0 h_0)$.

Similarly, the shearing stress per unit area at n , the upper edge of the web, is also nearly equal to $J \div b_0 h_0$ (see

$$\text{eq., 4 (§254) for then } \left[\int_{z' = -\frac{1}{2} h_0}^e (zdF) \right] = F_1 \cdot \frac{1}{2} h_0 \quad \text{nearly,}$$

while I remains as before.

The shear per unit area, then, in an ordinary I-beam is obtained by dividing the total shear J by the area of the web section.

EXAMPLE.—It is required to determine the proper thickness to be given to the web of the 15-inch wrought-iron rolled beam of Example 3 of §252, the height of web being 13 inches, with a safe shearing stress as low as 4000 lbs. per sq. in. (the practice of the N. J. Steel and Iron Co., for webs), the web being vertical.

The greatest total shear, J_m , occurring at either support and being equal to half the load (see table §250) we have with $b_0 =$ width of web,

$$Z_0 \text{ max.} = \frac{J_m}{b_0 h_0}; \text{ i.e. } 4000 = \frac{13950}{b_0 \times 13} \therefore b_0 = 0.26 \text{ inches.}$$

(Units, inch and pound). The 15-inch light beam of the N. J. Co. has a web $\frac{1}{2}$ inch thick, so as to provide for a shear double the value of that in the foregoing example. In the middle of the span $Z_s = 0$, since $J = 0$.

257. Designing of Riveting for Built Beams.—The latter are generally of the I-beam and box forms, made by riveting together a number of continuous shapes, most of the material being thrown into the flange members. *E. g.*, in fig. 259, an I-beam is formed by riveting together, in the manner shown in the figure, a “vertical stem plate” or web, four “angle-irons,” and two “flange-plates,” each of

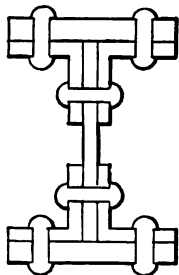

FIG. 259.

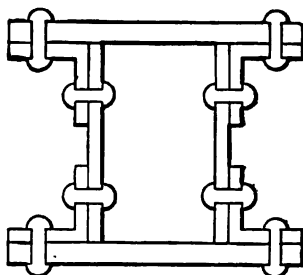

FIG. 260.

these seven pieces being continuous through the whole length of the beam. Fig 260 shows a box-girder. If the riveting is well done, the combination forms a single rigid beam whose safe load for a given span may be found by foregoing rules; in computing the moment of inertia, however, the portion of cross section cut out by the rivet holes must not be included. (This will be illustrated in a subsequent paragraph.) The safe load having been computed from a consideration of normal stresses only, and the web being made thick enough to take up the max. total shear, J_m , with safety, it still remains to design the riveting, through whose agency the web and flanges are caused to act together as a single continuous rigid mass. It will be on the side of safety to consider that at a given

locality in the beam the shear carried by the rivets connecting the angles and flanges, per unit of length of beam, is the same as that carried by those connecting the angles and the web ("vertical stem-plate"). The amount of this shear may be computed from the fact that it is equal to that occurring in the surface (parallel to the neutral surface) in which the web joins the flange, in case the web and flange were of continuous substance, as in a solid I-beam. But this shear must be of the same amount per horizontal unit of length as it is per vertical linear unit in the web itself, where it joins the flange; (for from § 254 $Z = X$.) But the shear in the vertical section of the web, being uniformly distributed, is the same per vertical linear unit at the junction with the flange as at any other part of the web section (§ 256,) and the whole shear on the vertical section of web = J , the "total shear" of that section of the beam.

Hence we may state the following:

The riveting connecting the angles with the flanges, (or the web with the angles) in any locality of a built beam, must safely sustain a shear equal to J on a horizontal length equal to the height of web.

The strength of the riveting may be limited by the resistance of the rivet to being sheared (and this brings into account its cross section) or upon the crushing resistance of the side of the rivet hole in the plate (and this involves both the diameter of the rivet and the thickness of the metal in the web, flange, or angle.) In its practice the N. J. Steel and Iron Co. allows 7500 lbs. per sq. inch shearing stress in the rivet (wrought iron), and 12500 lbs. per sq. inch compressive resistance in the side of the rivet-hole, the axial plane section of the hole being the area of reference.

In fig. 259 the rivets connecting the web with the angles are in *double shear*, which should be taken into account in considering their shearing strength, which is then double; those connecting the angles and the flange plates are in

single shear. In fig. 260 (box-beam) where the beam is built of two webs, four angles, and two flange plates, all the rivets are in single shear. If the web plate is very high compared with its thickness, vertical stiffeners in the form of T irons may need to be riveted upon them laterally [see § 314].

EXAMPLE.—A built I-beam of wrought iron (see fig. 259) is to support a uniformly distributed load of 40 tons, its extremities resting on supports 20 feet apart, and the height and thickness of web being 20 ins. and $\frac{1}{2}$ in. respectively. How shall the rivets, which are $\frac{7}{8}$ in. in diameter, be spaced, between the web and the angles which are also $\frac{1}{2}$ in. in thickness? Referring to fig. 235 we find that $J = \frac{1}{2} W = 20$ tons at each support and diminishes regularly to zero at the middle, where no riveting will therefore be required. (Units inch and pound). Near a support the riveting must sustain for each inch of length of beam a shearing force of $(J \div \text{height of web}) = 40000 \div 20 \text{ in.} = 2000 \text{ lbs.}$ Each rivet, having a sectional area of $\frac{1}{4} \pi (\frac{7}{8})^2 = 0.60 \text{ sq. inches,}$ can bear a safe shear of $0.60 \times 7500 = 4500 \text{ lbs.}$ in single shear, and \therefore of 9000 lbs. in double shear, which is the present case. But the safe compressive resistance of the side of the rivet hole in either the web or the angle is only $\frac{7}{8} \text{ in.} \times \frac{1}{2} \text{ in.} \times 12500 = 5470 \text{ lbs.,}$ and thus determines the spacing of the rivets as follows:

$2000 \text{ lbs.} \div 5470$ gives 0.36 as the number of rivets per inch of length of beam, i.e., they must be $1 \div 0.36 = 2.7$ inches apart, centre to centre, near the supports; 5.4 inches apart at $\frac{1}{4}$ the span from a support; none at all in the middle.

However, "the rivets should not be spaced closer than $2\frac{1}{2}$ times their diameter, nor farther apart than 16 times the thickness of the plate they connect," is the rule of the N. J. Co.

As for the rivets connecting the angles and flange plates, being in two rows and opposite (in pairs) the safe shear-

ing resistance of a pair (each in single shear) is 9,000 lbs., while the safe compressive resistance of the sides of the two rivet holes in the angle irons (the flange plate being much thicker) is = 10,940 lbs. Hence the former figure (9,000) divided into 2,000 lbs., gives 0.22 as the number of pairs of rivets per inch of length of the beam ; i.e., the rivets in one row should be spaced 4.5 inches apart, centre to centre, near a support ; the interval to be increased in inverse ratio to the distance from the middle of span, (bearing in mind the practical limitation just given).

If the load is concentrated in the middle of the span, instead of uniformly distributed, J is constant along each half-span, (see fig. 234) and the rivet spacing must accordingly be made the same at all localities of the beam.

SPECIAL PROBLEMS IN FLEXURE.

258. Designing Cross Sections of Built Beams.—The last paragraph dealt with the riveting of the various plates ; we now consider the design of the plates themselves. Take for instance a built I-beam, fig. 261 ; one vertical stem-

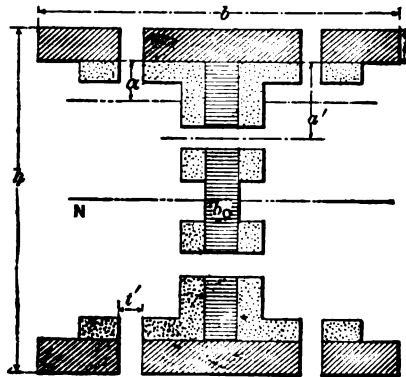

FIG. 261.

plate, four angle irons, (each of sectional area = A , remaining after the holes are punched, with a gravity axis parallel to, and at a distance = a from its base), and two flange plates of width = b , and thickness = t . Let the whole depth of girder = h , and the diameter of a rivet hole = t' . To safely resist the tensile and compressive forces induced in this section by M_m inch-lbs. (M_m being the greatest moment in the beam which is prismatic) we have from § 239,

$$M_m = \frac{R'I}{e} \quad (1)$$

R' for wrought iron = 12,000 lbs. per sq. inch, e is = $\frac{1}{2} h$ while I , the moment of inertia of the compound section, is obtained as follows, taking into account the fact that the rivet holes cut out part of the material. In dealing with the sections of the angles and flanges, we consider them concentrated at their centres of gravity (an approximation, of course,) and treat their moments of inertia about N as single terms in the series $\int dF x^2$

(see § 85). The subtractive moments of inertia for the rivet holes in the web are similarly expressed; let b_0 = thickness of web.

$$\therefore \begin{cases} I_N \text{ for web} = \frac{1}{12} b_0 (h-2t)^3 - 2b_0 t' \left[\frac{h}{2} - t - a \right]^2 \\ I_N \text{ for four angles} = 4A \left[\frac{h}{2} - t - a \right]^2 \\ I_N \text{ for two flanges} = 2(b-2t') t \left(\frac{h-t}{2} \right)^2 \end{cases}$$

the sum of which makes the I_N of the girder. Eq. (1) may now be written

$$\frac{M_m \bar{h}}{2R'} = I_N \quad (2)$$

which is available for computing any one unknown quantity. The quantities concerned in I_N are so numerous and they are combined in so complex a manner that in any numerical example it is best to adjust the dimensions of the section to each other by successive assumptions and

trials. The size of rivets need not vary much in different cases, nor the thickness of the web-plate, which as used by the N. J. Co. is "rarely less than $\frac{1}{4}$ or more than $\frac{5}{8}$ inch thick." The same Co. recommends the use of a single size of angle irons, viz., $3'' \times 3'' \times \frac{1}{2}''$, for built girders of heights ranging from 12 to 36 inches, and also $\frac{3}{4}$ in. rivets, and gives tables computed from eq. (2) for the proportionate strength of each portion of the compound section.

EXAMPLE.—(Units, inch and pound). A built I-beam with end supports, of span = 20 ft. = 240 inches, is to support a uniformly distributed load of 36 tons = 72,000 lbs. If $\frac{3}{4}$ inch rivets are used, angle irons $3'' \times 3'' \times \frac{1}{2}''$, vertical web $\frac{1}{2}''$ in thickness, and plates 1 inch thick for flanges, how wide ($b = ?$) must these flange-plates be ? taking $h = 22$ inches = total height of girder.

Solution.—From the table in § 250 we find that the max. M for this case is $\frac{1}{8} Wl$, where W = the total distributed load (including the weight of the girder) and l = span. Hence the left hand member of eq. (2) reduces to

$$\frac{Wl}{16} \cdot \frac{h}{R^2} = \frac{72000 \times 240 \times 22}{16 \times 12000} = 1980$$

That is, the total moment of inertia of the section must be = 1,980 biquad. inches, of which the web and angles supply a known amount, since $b_0 = \frac{1}{2}''$, $t = 1''$, $t' = \frac{3}{4}''$, $a' = 1\frac{3}{4}''$, $A = 2.0$ sq. in., $a = 0.9'$, and $h = 22''$, are known, while the remainder must be furnished by the flanges, thus determining their width b , the unknown quantity.

The *effective* area, A , of an angle iron is found thus: The full sectional area for the size given, = $3 \times \frac{1}{2} + 2\frac{1}{2} \times \frac{1}{2} = 2.75$ sq. inches, from which deducting for two rivet holes we have

$$A = 2.75 - 2 \times \frac{3}{4} \times \frac{1}{2} = 2.0 \text{ sq. in.}$$

The value $a = 0.90'$ is found by cutting out the shape

of two angles from sheet iron, thus : and balancing it on a knife edge. (The gaps left by the rivet holes may be ignored, without great error, in finding a). Hence, substituting we have

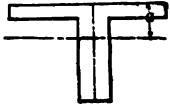

Fig. 261 a.

$$I_N \text{ for web} = \frac{1}{12} \cdot \frac{1}{2} \times 20^3 - 2 \times \frac{1}{2} \cdot \frac{3}{4} [8\frac{1}{4}]^2 = 282.3$$

$$I_N \text{ for four angles} = 4 \times 2 \times [9.10]^2 = 662.5$$

$$I_N \text{ for two flanges} = 2(b - \frac{6}{4}) \times 1 \times (10\frac{1}{2})^2 = 220.4(b - 1.5)$$

$$\therefore 1980 = 282.3 + 662.5 + (b - 1.5)220.4$$

$$\text{whence } b = 4.6 + 1.5 = 6.1 \text{ inches}$$

the required total width of each of the 1 in. flange plates. This might be increased to 6.5 in. so as to equal the united width of the two angles and web.

The rivet spacing can now be designed by § 257, and the assumed thickness of web, $\frac{1}{2}$ in., tested for the max. total shear by § 256. The latter test results as follows: The max. shear J_m occurs near either support and = $\frac{1}{2}W = 36,000$ lbs. \therefore , calling b'_0 the least allowable thickness of web in order to keep the shearing stress as low as 4,000 lbs. per sq. inch,

$$b'_0 \times 20'' \times 4000 = 36000 \therefore b'_0 = 0.45''$$

showing that the assumed width of $\frac{1}{2}$ in. is safe.

This girder will need vertical stiffeners near the ends, as explained subsequently, and is understood to be supported laterally. Built beams of double web, or box-form, (see Fig. 260) do not need this lateral support.

259. Set of Moving Loads.—When a locomotive passes over a number of parallel prismatic girders, each one of which experiences certain detached pressures corresponding to the different wheels, by selecting any definite position of the wheels on the span, we may easily compute the reactions of the supports, then form the shear diagram, and finally as in § 243 obtain the max. moment, M_m , and the

max. shear J_m , for this particular position of the wheels. But the values of M_m and J_m for some other position may be greater than those just found. We therefore inquire which will be the greatest moment among the infinite number of (M_m)'s (one for each possible position of the wheels on the span). It is evident from Fig. 236 from the nature of the moment diagram, that when the pressures or loads are detached, the M_m for any position of the loads, which of course are in this case at fixed distances apart, must occur under one of the loads (i.e. under a wheel). We begin \therefore by asking: What is the position of the set of moving loads when the moment under a given wheel is greater than will occur under that wheel in any other position? For example, in Fig. 262, in what position of the

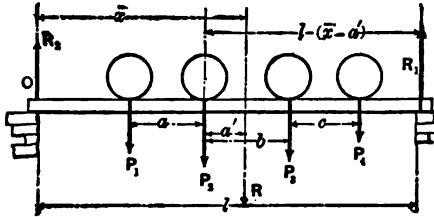

Fig 262.

loads P_1, P_2 , etc. on the span will the moment M_2 , i.e., under P_2 , be a maximum as compared with its value under P_2 in any other position on the span. Let R be the resultant of the loads which are now on the span, its variable distance from O be $= \bar{x}$, and its fixed distance from $P_2 = a'$; while a, b, c , etc., are the fixed distances between the loads (wheels). For any values of \bar{x} , as the loading moves through the range of motion within which no wheel of the set under consideration goes off the span, and no new wheel comes on it, we have $R_1 = \frac{\bar{x}}{l} R$, and the moment under P_2

$$-M_2 = R_1[l - (\bar{x} - a')] - P_3b - P_4(b + c)$$

$$\text{i.e. } M_2 = \frac{R}{l} (l\bar{x} - \bar{x}^2 + a'\bar{x}) - P_3b - P_4(b + c) \dots \dots \dots (1)$$

In (1) we have M_2 as a function of \bar{x} , all the other quantities in the right hand member remaining constant as the loading moves; \bar{x} may vary from $\bar{x}=a+a'$ to $\bar{x}=l-(c+b-a')$. For a max. M_2 , we put $dM_2 \div d\bar{x}=0$, i. e.

$$\frac{R}{l}(l-2\bar{x}+a')=0 \therefore \bar{x} \text{ (for Max } M_2) = \frac{1}{2}l + \frac{1}{2}a'$$

(For this, or any other value of \bar{x} , $d^2M_2 \div d\bar{x}^2$ is negative, hence a maximum is indicated). For a max. M_2 , then, R must be as far ($\frac{1}{2}a'$) on one side of the middle of the span as P_2 is on the other; i.e., as the loading moves, the moment under a given wheel becomes a max. when that wheel and the centre of gravity of all the loads (*then on the span*) are equi-distant from the middle of the span.

In this way in any particular case we may find the respective max. moments occurring under each of the wheels during the passage, and the greatest of these is the M_m to be used in the equation $M_m = R'I \div c$ for safe loading.*

As to the shear J , for a given position of the wheels this will be the greatest at one or the other support, and equals the reaction at that support. When the load moves toward either support the shear at that end of the beam evidently increases so long as no wheel rolls completely over and beyond it. To find J max., then, dealing with each support in turn, we compute the successive reactions at the support when the loading is successively so placed that consecutive wheels, in turn, are on the point of rolling off the girder at that end; the greatest of these is the max. shear, J_m . As the max. moment is apt to come under the heaviest load it may not be necessary to deal with more than one or two wheels in finding M_m .

EXAMPLE.—Given the following wheel pressures,

$$A < \dots 8 \dots > B < \dots 5' \dots > C < \dots 4 \dots < D$$

4 tons. 6 tons. 6 tons. 5 tons.

on one rail which is continuous over a girder of 20 ft. span, under a locomotive.

* Since this may be regarded as a case of "sudden application" of a load, it is customary to make R' much smaller than for a dead load; from one-third to one-half smaller.

1. Required the position of the resultant of A , B , and C ;
2. " " " " A , B , C , and D ;
3. " " " " B , C , and D .
4. In what position of the wheels on the span will the moment under B be a max.? Ditto for wheel C ? Required the value of these moments and which is M_m ?
5. Required the value of J_m , (max. shear), its location and the position of loads.

Results—(1.) 7.8' to right of A . (2.) 10' to right of A . (3.) 4.4' to right of B . (4.) Max. $M_B = 1,273,000$ inch lbs. with all the wheels on; Max. $M_C = 1,440,000$ inch-lbs. with wheels B , C , and D on. (5.) $J_m = 13.6$ tons at right support with wheel D close to this support.

260. Single Eccentric Load.—In the following special cases of prismatic beams, peculiar in the distribution of the loads, or mode of support, or both, the main objects sought are the values of the max. moment M_m , for use in the equation

$$M_m = \frac{R'I}{e} \text{ (see §239);}$$

and of the max. shear J_m , from which to design the web riveting in the case of an I or box-girder. The modes of support will be such that the reactions are independent of the form and material of the beam (the weight of beam being neglected).

As before, the flexure is to be slight, and the forces are all perpendicular to the beam.

The present problem is that in fig. 263, the beam being prismatic, supported at the ends, with a single eccentric load, P . We shall first disregard the weight of the beam itself. Let the span $= l_1 + l_2$. First considering the whole beam free we have the reactions $R_1 = Pl_2 \div l$ and $R_2 = Pl_1 \div l$.

Making a section at m and having Om free, x being $< l_2$, Σ (vert. comps.) = 0 gives

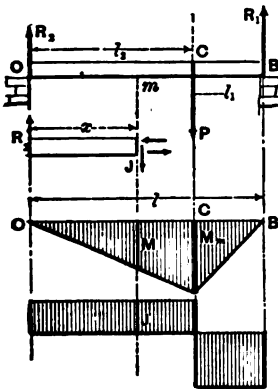

FIG. 263.

$$R_2 - J = 0, \text{ i.e., } J = R_2;$$

while from $\Sigma (\text{mom.})_m = 0$ we have

$$\frac{PI}{e} - R_2 x = 0 \therefore M = R_2 x = \frac{Pl_1}{l} x$$

These values of J and M hold good between O and C , J being constant, while M is proportional to x . Hence for OC the shear diagram is a rectangle and the moment diagram a triangle. By inspection the greatest M for OC is for $x = l_2$, and $= Pl_1 l_2 + l$. This is the max. M for the beam, since between C and B , M is proportional to the distance of the section from B .

$$\therefore M_m = \frac{Pl_1 l_2}{l} \text{ and } \frac{R'I}{e} = \frac{Pl_1 l_2}{l} \quad \dots \quad (1)$$

is the equation for safe loading.

$J = R_1$ in any section along CB , and is opposite in sign to what it is on OC ; i.e., practically, if a dove-tail joint existed anywhere on OC the portion of the beam on the right of such section would slide downward relatively to the left hand portion; but vice versâ on CB .

Evidently the max. shear $J_m = R_1$ or R_2 , as l_2 or l_1 is the greater segment.

It is also evident that for a given span and given beam the safe load P , as computed from eq. (1) above, becomes very large as its point of application approaches a support; this would naturally be expected but not without limit, as the shear for sections between the load and the support is equal to the reaction at the near support and may thus soon reach a limiting value, when the safety of the web or the spacing of the rivets, if any, is considered.

Secondly, considering the *weight of the beam*, or any *uniformly distributed loading*, weighing w lbs. per unit of length of beam, in addition to P , Fig. 264, we have the reactions

$$R_1 = \frac{Pl_2}{l} + \frac{W}{2}; \text{ and } R_2 = \frac{Pl_1}{l} + \frac{W}{2}$$

Let l_2 be $> l_1$; then for a portion Om of length $x < l_2$ moments about m give

$$\frac{pI}{e} - R_2x + wx \cdot \frac{x}{2} = 0$$

i.e., on OC , $M = R_2x - \frac{1}{2}wx^2$ (2)

Evidently for $x = 0$ (i.e. at O) $M = 0$, while for $x = l_2$ (i.e. at C) we have, putting $w = W \div l$

$$M_C = R_2l_2 - \frac{1}{2}wl_2^2 = \frac{Pl_1l_2}{l} + \frac{Wl_2}{2} - \frac{1}{2}\frac{Wl_2^2}{l} \quad (3)$$

It remains to be seen whether a value of M may not exist in some section between O and C , (i.e., for a value of $x < l_2$ in eq. (2)), still greater than M_C . Since (2) gives M as a continuous function of x between O and C , we put $dM \div dx = 0$, and obtain, substituting the value of the constants R_2 and w ,

$$R_2 - wx = 0 \therefore x_n \left\{ \begin{array}{l} \text{max.} \\ \text{or} \\ \text{min.} \end{array} \right\} = \frac{Pl_1}{W} + \frac{1}{2}l \quad (4)$$

This must be for M max., since $d^2M \div dx^2$ is negative

when this value of x is substituted. If the particular value of x given by (4) is $< l_2$, the corresponding value of M (call it M_n) from eq. (2) will occur on OC and will be greater than M_C (Diagrams II. in fig. 264 show this case); but if x_n is $> l_2$, we are not concerned with the corresponding value of M , and the greatest M on OC would be M_C .

For the short portion BC , which has moment and shear diagrams of its own not continuous with those for OC , it may easily be shown that M_C is the greatest moment of any section. Hence the M

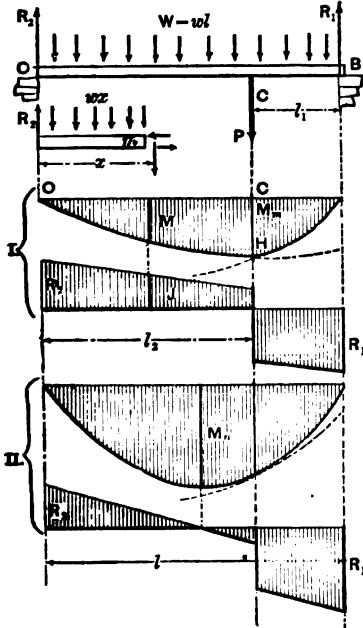

FIG. 264.

max., or M_m , of the whole beam is either M_c or M_n , according as x_n is $>$ or $<$ l_2 . This latter criterion may be expressed thus, [with $l_1 - \frac{1}{2}l$ denoted by l_3 , the distance of P from the middle of the span] :

From (eq. 4) $\left[\left(\frac{Pl_1}{W} + \frac{1}{2}l\right) > l_2\right]$ is equivalent to $\left[\left(\frac{P}{W}\right) > \left(\frac{l_3}{l_1}\right)\right]$

and since from (4) and (2)

$$M_n = \left[\frac{Pl_1}{l} + \frac{1}{2}W\right] \left[\frac{Pl_1}{W} + \frac{1}{2}l\right] - \frac{1}{2}\frac{W}{l} \left[\frac{Pl_1}{W} + \frac{1}{2}l\right]^2 \quad (5)$$

The equation for safe loading is

$$\left. \begin{aligned} \frac{R'I}{e} = M_c, \text{ when } \frac{P}{W} \text{ is } > \frac{l_3}{l_1} \\ \text{and} \\ \frac{R'I}{e} = M_n, \text{ when } \frac{P}{W} \text{ is } < \frac{l_3}{l_1} \end{aligned} \right\} \begin{array}{l} \text{See eqs. (3) and (5)} \\ \text{for } M_c \text{ and } M_n \end{array} \quad (6)$$

If either P , W , l_3 , or l_1 is the unknown quantity sought, the criterion of (6) cannot be applied, and we \therefore use both equations in (6) and then discriminate between the two results.

The greatest shear is $J_m = R_1$, in Fig. 264, where l_1 is $>$ l_1 .

261. Two Equal Terminal Loads, Two Symmetrical Supports Fig. 265. [Same case as in Fig. 231, § 238]. Neglect weight of beam. The reaction at each support being $=P$, (from symmetry), we have for a free body Om with $x <$ l_1

$$Px - \frac{pI}{e} = 0 \therefore M = Px \quad . \quad . \quad (1)$$

while where $x >$ l_1 and $<$ $l_1 + l_2$

$$Px - P(x - l_1) - \frac{pI}{e} = 0 \therefore M = Pl_1 \quad . \quad (2)$$

That is, see (1), M varies directly with x between O and C , while between C and D it is constant. Hence for safe loading

$$\frac{R'I}{e} = M_m \text{ i.e., } \frac{R'I}{e} = Pl_1 \quad . \quad . \quad (3)$$

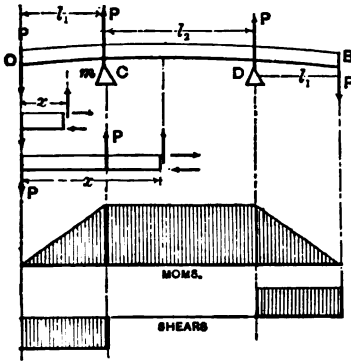

FIG. 265

The construction of the moment diagram is evident from equations (1) and (2).

As for J , the shear, the same free bodies give, from Σ (vert. forces)=0.

On $OC \quad J=P \quad \dots (4)$

On $CD \quad J=P-P=zero (5)$

(4) and (5) might also be obtained from (1) and (2) by writing $J=dM \div dx$, but the

former method is to be preferred in most cases, since the latter requires M to be expressed as a function of x while the former is applicable for examining separate sections without making use of a variable.

If the beam is an I-beam, the fact that J is zero anywhere on CD would indicate that we may dispense with a web along CD to unite the two flanges; but the lower flange being in compression and forming a "long column" would tend to buckle out of a straight line if not stayed by a web connection with the other, or some equivalent bracing.

262. Uniform Load over Part of the Span. Two End Supports. Fig. 266. Let the load = W , extending from one support over a portion = c , of the span, (on the left, say) so that $W=wc$, w being the load per unit of length. Neglect weight of beam. For a free body Om of any length $x < OB$ (i.e. $< c$), $\Sigma moms_m=0$ gives

$$\frac{pI}{e} + \frac{wx^2}{2} - R_1x = 0 \therefore M = R_1x - \frac{wx^2}{2} \quad \dots (1)$$

which holds good for any section on OB . As for sections on BC it is more simple to deal with the free body $m'C$, of length

$$x' < CB \text{ from which we have } M = R_2 x' \quad \dots (2)$$

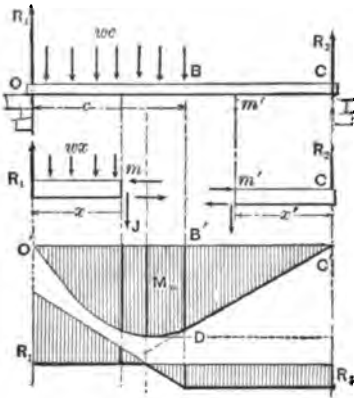

FIG. 266.

which shows the moment curve for BC to be a straight line DC , tangent at D to the parabola OD representing eq. (1). (If there were a concentrated load at B , CD would meet the tangent at D at an angle instead of coinciding with it; let the student show why, from the shear diagram).

The shear for any value of x on OB is :

$$\begin{aligned} \text{On } OB \quad \dots \quad J &= R_1 - wx \quad \dots \quad (3) \\ \text{while on } BC \quad \dots \quad J &= R_2 = \text{constant} \quad \dots \quad (4) \end{aligned}$$

The shear diagram is constructed accordingly.

To find the position of the max. ordinate of the parabola, (and this from previous statements concerning the tangent at the point D must occur on OB , as will be seen and will \therefore be the M_m for the whole beam) we put $J=0$ in eq (3) whence

$$x \text{ (for } M_m) = \frac{R_1}{w} = \frac{W}{w} \frac{[l - \frac{c}{2}]}{l} = c - \frac{c^2}{2l} \quad \dots \quad (5)$$

and is less than c , as expected. [The value of $R_1 = \frac{W}{l} (l - \frac{c}{2})$,

$-(wc \div l) (l - \frac{c}{2})$, (the whole beam free) has been substituted]. This value of x substituted in eq. (1) gives

$$M_m = (1 - \frac{1}{2} \frac{c}{l})^2 \cdot \frac{1}{2} \cdot Wc \therefore \frac{R'I}{e} = \frac{1}{2} [1 - \frac{1}{2} \cdot \frac{c}{l}]^2 Wc \dots \quad (6)$$

is the equation for safe loading.

The max. shear J_m is found at O and is $= R_1$, which is evidently $> R_2$, at C .

263. Uniform Load Over Whole Length With Two Symmetrica Supports. Fig. 267.—With the notation expressed in the figure, the following results may be obtained, after having divided the length of the beam into three parts for separate treatment as necessitated by the external forces, which are the distributed load W , and

and the two reactions, each = $\frac{1}{2} W$. The moment curve is made up of parts of three distinct parabolas, each with its axis vertical. The central parabola may sink below the horizontal axis of reference if the supports are far enough apart, in which case (see Fig.) the elastic curve of the beam itself becomes concave upward between the points E and F of “contrary flexure.” At each of these points the moment must be zero, since the radius of curvature is ∞ and $M = EI \div \rho$ (see § 231) at any section; that is, at these points the moment curve crosses its horizontal axis.

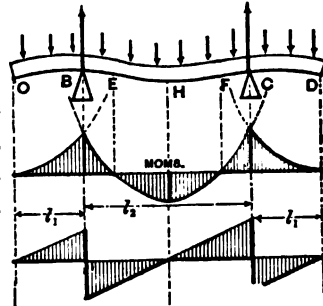

FIG. 267.

As to the location and amount of the max. moment M_m , inspecting the diagram we see that it will be either at H , the middle, or at both of the supports B and C (which from symmetry have equal moments), i.e., (with l = total length,)

$$M_m \left[\text{and } \therefore \frac{R'I}{e} \right] = \begin{cases} \text{either } \frac{W}{2l} \left[\frac{1}{4} l_2^2 - l_1^2 \right] \dots \dots \text{ at } H \\ \text{or } \frac{W}{2l} l_1^2 \dots \dots \text{ at } B \text{ and } C \end{cases}$$

according to which is the greater in any given case; i.e. according as l_2 is $>$ or $<$ $l_1 \sqrt{8}$.

The shear close on the left of $B = w l_1$, while close to the right of B it = $\frac{1}{2} W - w l_1$. (It will be noticed that in this case since the beam *overhangs*, beyond the support, the shear near the support is not equal to the reaction there, as it was in some preceding cases.)

Hence $J_m = \left\{ \frac{wl_1}{2W} - wl_1 \right\}$ according as $l_1 > \frac{1}{4}l$

264. **Hydrostatic Pressure Against a Vertical Plank.**—From elementary hydrostatics we know that the pressure, per unit area, of quiescent water against the vertical side of a tank, varies directly with the depth, x , below the surface, and equals the weight of a prism of water whose altitude = x , and whose sectional area is unity. See Fig. 268.

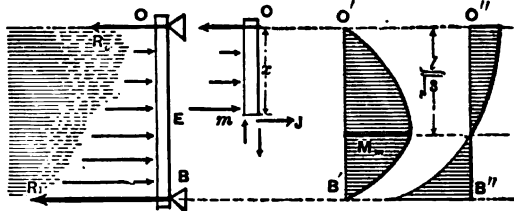

FIG. 268.

The plank is of rectangular cross section, its constant breadth, = b , being \perp to the paper, and receives no support except at its two extremities, O and B , O being level with the water surface. The loading, or pressure, per unit of length of the beam, is here variable and, by above definition, is = $w = \gamma xb$, where γ = weight of a cubic unit (i.e. the heaviness, see § 7) of water, and $x = Om$ = depth of any section m below the surface. The hydrostatic pressure on $dx = wdx$. These pressures for equal dx 's, vary as the ordinates of a triangle OR_1B .

Consider Om free. Besides the elastic forces of the exposed section m , the forces acting are the reaction R_0 , and the triangle of pressure OEm . The total of the latter is

$$W_x = \int_0^x w dx = \gamma b \int_0^x x dx = \gamma b \frac{x^2}{2} \dots \dots \quad (1)$$

and the sum of the moments of these pressures about m is equal to that of their resultant (= their sum, since they are parallel) about m , and $\therefore = \gamma b \frac{x^2}{2} \cdot \frac{x}{3}$.

[From (1) when $x = l$, we have for the total water pressure on the beam $W_1 = \gamma b \frac{l^2}{2}$ and since one-third of this will be borne at O we have $R_0 = \frac{1}{6} \gamma b l^2$.]

Now putting Σ (mom. about the neutral axis of m) = 0, for Om free, we have

$$R_0 x - W_x \cdot \frac{x}{3} - \frac{pI}{e} = 0 \therefore M = \frac{1}{6} \gamma b (l^2 x - x^3) \dots \dots \dots (2)$$

(which holds good from $x = 0$ to $x = l$). From Σ (horiz. forces) = 0 we have also the shear

$$J = R_0 - W_x = \frac{1}{6} \gamma b (l^2 - 3x^2) \dots \dots \dots (3)$$

as might also have been obtained by differentiating (2), since $J = dM \div dx$. By putting $J = 0$ (§ 240, corollary) we have for a max. M , $x = l \div \sqrt{3}$, which is less than l and hence is applicable to the problem. Substitute this in eq. 2, and reduce, and we have

$$\frac{R'I}{e} = M_m, \text{ i.e. } \frac{R'I}{e} = \frac{1}{9} \cdot \frac{1}{\sqrt{3}} \cdot \gamma b l^3 \dots \dots \dots (4)$$

as the equation for safe loading.

265. Example.—If the thickness of the plank is h , required $h = ?$, if R' is taken = 1,000 lbs. per sq. in. for timber (§ 251), and $l = 6$ feet. For the *inch-pound-second* system of units, we must substitute $R' = 1,000$; $l = 72$ inches; $\gamma = 0.036$ lbs. per cubic inch (heaviness of water in this system of units); while $I = bh^3 \div 12$, (§ 247), and $e = \frac{1}{2} h$. Hence from (4) we have

$$\frac{1000 bh^3}{12 \times \frac{1}{2} h} = \frac{0.036b \times 72^3}{9 \sqrt{3}}, \therefore h^2 = 5.16 \therefore h = 2.27 \text{ in.}$$

It will be noticed that since x for $M_m = l \div \sqrt{3}$, and not $\frac{2}{3} l$, M_m does not occur in the section opposite the resultant of the water pressure; see Fig. 268. The shear curve is a parabola here; eq. (3).

268. The Four x-Derivatives of the Ordinate of the Elastic Curve—If $y = \text{func.}(x)$ is the equation of the elastic curve for any portion of a loaded beam, on which portion the load per unit of length of the beam is $w =$ either zero, (Fig. 234) or $=$ constant, (Fig. 235), or $=$ a continuous func. (x)

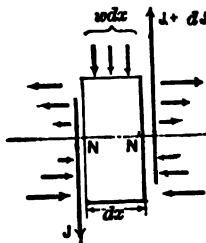

FIG. 268.

(as in the last §), we may prove, as follows, that $w =$ the x -derivative of the shear. Fig. 269. Let N and N' be two consecutive cross-sections of a loaded beam, and let the block between them, bearing its portion, $w dx$, of a distributed load, be considered free. The elastic forces consist of the two stress-couples (tensions and compressions) and the two shears, J and $J + dJ$, dJ being the shear-increment consequent upon x receiving its increment dx . By putting $\Sigma(\text{vert. components}) = 0$ we have

$$J + dJ - w dx - J = 0 \therefore w = \frac{dJ}{dx}$$

Q. E. D. But J itself $= dM \div dx$, (§ 240) and $M = [d^2y \div dx^2] EI$. By substitution, then, we have the following relations :

$$y = \text{func.}(x) = \text{ordinate at any point of the elastic curve} \quad (1)$$

$$\frac{dy}{dx} = a = \text{slope at any point of the elastic curve} \quad \dots \quad (2)$$

$$EI \frac{d^2y}{dx^2} = M = \text{ordinate (to scale) of the moment curve} \quad (3)$$

$$EI \frac{d^3y}{dx^3} = \text{the shear, } J = \left\{ \begin{array}{l} \text{the ordinate (to scale)} \\ \text{of the shear diagram} \end{array} \right\} \quad \dots \quad (4)$$

$$EI \frac{d^4y}{dx^4} = w = \left\{ \begin{array}{l} \text{the load per unit of length} \\ \text{of beam} = \text{ordinate (to scale)} \\ \text{of a curve of loading.} \end{array} \right\} \quad \dots \quad (5)$$

If, then, the equation of the elastic curve (the neutral line of the beam itself; a reality, and not artificial like the

other curves spoken of) is given; we may by successive differentiation, for a prismatic and homogeneous beam so that both E and I are constant, find the other four quantities mentioned.

As to the converse process, (i.e. having given w as a function of x , to find expressions for J , M and y as functions of x) this is more difficult, since in taking the x -anti-derivative, an unknown constant must be added and determined. The problem just treated in § 264, however, offers a very simple case since w is the same function of x , along the whole beam, and there is therefore but one elastic curve to be determined.

We ∴ begin, numbering backward, with

$$EI \frac{d^4y}{dx^4} = -\gamma bx \left\{ \begin{array}{l} \text{since } w = \gamma bx, \text{ see } \\ \text{last } \S \text{ and Fig. 268} \end{array} \right\} \dots \dots (5a)$$

[N. B.—This derivative ($dJ \div dx$) is negative since dJ and dx have contrary signs.]

$$\therefore (\text{shear} =) EI \frac{d^3y}{dx^3} = -\gamma b \frac{x^2}{2} + \text{Const.}$$

But writing out this equation for $x=0$, i.e. for the point O , where the shear= R_0 , we have $R_0 = 0 + \text{Const.} \therefore \text{Const.} = R_0$, and hence write

$$EI \frac{d^3y}{dx^3} = -\gamma b \frac{x^2}{2} + R_0 \dots (\text{Shear}) \dots (4a)$$

Again taking the x -anti-derivative of both sides

$$(\text{Moment} =) EI \frac{d^2y}{dx^2} = -\gamma b \frac{x^3}{6} + R_0 x + (\text{Const.} = 0) \dots (3a)$$

[At O , $x=0$ also M , ∴ $\text{Const.} = 0$]. Again,

$$EI \frac{dy}{dx} = -\gamma b \frac{x^4}{24} + R_0 \frac{x^2}{2} + C'$$

At O , where $x=0$ $dy \div dx = \alpha_0$ = the unknown slope of the elastic line at O , and hence $C' = EI \alpha_0$

$$\therefore EI \frac{dy}{dx} = -\gamma b \frac{x^4}{24} + R_0 \frac{x^2}{2} + EI \alpha_0 \dots \dots (2a)$$

Passing now to y itself, and remembering that at O , both y and x are zero, so that the constant, if added, would= zero, we obtain (inserting the value of R_0 from last §)

$$EIy = -r b \frac{x^2}{120} + r b l^2 \frac{x^3}{36} + EIa_0 x \quad . \quad (1a)$$

the equation of the elastic curve. This, however, contains the unknown constant a_0 =the slope at O . To determine a_0 write out eq. (1a) for the point B , Fig. 268, where x is known to be equal to l , and y to be = zero, solve for a_0 , and insert its value both in (1a) and (2a). To find the point of max. y (i.e., of greatest deflection) in the elastic curve, write the slope, i.e. $dy \div dx$, = zero [see eq. 2a] and solve for x ; four values will be obtained, of which the one lying between 0 and l is obviously the one to be taken. This value of x substituted in (1a) will give the maximum deflection. The location of this maximum deflection is

neither at the centre of action of the load ($x = \frac{2}{3} l$) nor at the section of max. moment ($x = l \div \sqrt{3}$.)

The qualities of the left hand members of equations (1) to (5) should be carefully noted. *E. g.*, in the inch-pound-second system of units we should have :

1. y (a linear quantity) = (so many) inches.
2. $dy \div dx$ (an abstract number) = (so many) abstract units.
3. M (a moment) = (so many) inch-pounds.
4. J (a shear, i.e., force) = (so many) pounds.
5. w (force per linear unit) = (so many) pounds per running inch of beam's length.

As to the quantities E , and I , individually, E is pounds per sq. in., and I has four linear dimensions, i.e. (so many) bi-quadratic inches.

267. Resilience of Beam With End Supports.—Fig. 270. If a mass whose weight is G (G large compared with that of beam) be allowed to fall freely through a height $= h$ upon the centre of a beam supported at its extremities, the pressure P felt by the beam increases from zero at the first instant of contact up to a maximum P_m , as already stated in §233*a*, in which the equation was derived, d_m being small compared with h ,

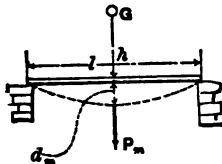

FIG. 270.

$$Gh = \frac{1}{96} \cdot \frac{P_m^2 l^3}{EI} \quad (a)$$

The elastic limit is supposed not passed. In order that the maximum normal stress in any outer fibre shall at most be $= R'$, a safe value, (see table §251) we must put $\frac{RI}{e} = \frac{P_m l}{4}$ [according to eq. (2) §241,] i.e. in equation (a) above, substitute $P_m = [4 R'I] \div le$, which gives

$$Gh = \frac{1}{96} \cdot \frac{R'^2 l^3}{Ee^2} = \frac{1}{96} \cdot \frac{R'^2}{E} \cdot \frac{l^2}{e^2} \cdot Fl = \frac{1}{96} \cdot \frac{R'^2}{E} \cdot \frac{l^2}{e^2} V \quad (b)$$

having put $I = Fk^2$ (k being the radius of gyration §85) and $Fl = V$ the volume of the (prismatic) beam. From equation (b) we have the energy, Gh , (in ft.-lbs., or inch.-lbs.) of the vertical blow at the middle which the beam of Fig. 270 will safely bear, and any one unknown quantity can be computed from it, (but the mass of G should not be small compared with that of the beam.)

The energy of this safe impact, for two beams of the same material and similar cross-sections (similarly placed), is seen to be proportional to their volumes; while if furthermore their cross-sections are the same and similarly placed, the safe Gh is proportional to their lengths. (These same relations hold good, approximately, beyond the elastic limit.)

It will be noticed that the last statement is just the con-

verse of what was found in §245 for static loads, (the pressure at the centre of the beam being then equal to the weight of the safe load); for there the longer the beam (and \therefore the span) the less the safe load, in inverse ratio. As appropriate in this connection, a quotation will be given from p. 186 of "The Strength of Materials and Structures," by Sir John Anderson, London, 1884, viz.:

"It appears from the published experiments and statements of the Railway Commissioners, that a beam 12 feet long will only support $\frac{1}{2}$ of the load that a beam 6 feet long of the same breadth and depth will support, but that it will bear double the weight suddenly applied, as in the case of a weight falling upon it," (from the *same height*, should be added); "or if the same weights are used, the longer beam will not break by the weight falling upon it unless it falls through twice the distance required to fracture the shorter beam."

268. Combined Flexure and Torsion. Crank Shafts. Fig. 271. Let O_1B be the crank, and NO_1 the portion *projecting*

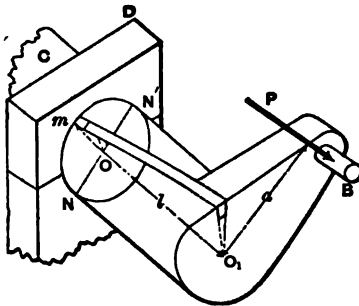

FIG. 271.

beyond the nearest bearing N . P is the pressure of the connecting-rod against the crank-pin at a definite instant, the rotary motion being uniform. Let a = the perpendicular dropped from the axis OO_1 of the shaft upon P , and l = the distance of P , along the axis OO_1 from the cross-section NmN' of the

shaft, close to the bearing. Let NN' be a diameter of this section, and parallel to a . In considering the portion NO_1B free, and thus exposing the circular section NmN' , we may assume that the stresses to be put in on the elements of this surface are the tensions (above NN') and the compressions (below NN') and shears \uparrow to NN' , due to the bending action of P ; and the shearing stress tan.

gent to the circles which have O as a common centre, and pass through the respective dF 's or elementary areas, these latter stresses being due to the twisting action of P .

In the former set of elastic forces let $p =$ the tensile stress per unit of area in the small parallelepipedical element m of the helix which is furthest from NN' (the neutral axis) and $I =$ the moment of inertia of the circle about NN' ; then taking moments about NN' for the free body, (disregarding the motion) we have as in cases of flexure (see §239)

$$\frac{pI}{r} = Pl; \text{ i.e., } p = \frac{Plr}{I} \quad . \quad . \quad (a)$$

[None of the shears has a moment about NN' .] Next taking moments about OO_1 , (the flexure elastic forces, both normal and shearing, having no moments about OO_1) we have as in torsion (§216)

$$\frac{p_s I_p}{r} = Pa; \text{ i.e., } p_s = \frac{Par}{I_p} \quad . \quad . \quad (b)$$

in which p_s is the shearing stress per unit of area, in the torsional elastic forces, on any outermost dF , as at m ; and I_p the polar moment of inertia of the circle about its centre O .

Next consider free, in Fig. 272, a small parallelepiped taken from the helix at m (of Fig. 271.) The stresses [see §209] acting on the four faces Γ to the paper in Fig. 272 are there represented, the dimensions (infinitesimal) being $a \parallel$ to NN' , $b \parallel$ to OO_1 , and $d \perp$ to the paper in Fig. 272.

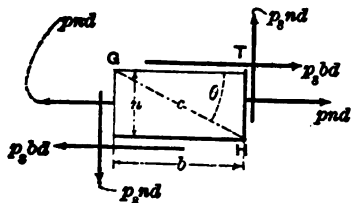

FIG. 272.

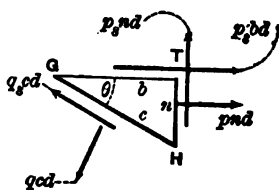

FIG. 273.

By altering the ratio of b to n we may make the angle θ what we please. It is now proposed to consider free the triangular prism, GHT , to find the intensity of normal stress q , per unit of area, on the diagonal plane GH , (of length= c ,) which is a bounding face of that triangular prism. See Fig. 273. By writing Σ (compons. in direction of normal to GH)=0, we shall have, transposing,

$$qcd=pnd \sin \theta+p, bd \sin \theta+p, nd \cos \theta; \text{ and solving for } q$$

$$q=p \frac{n}{c} \sin \theta+p, \left[\frac{b}{c} \sin \theta+\frac{n}{c} \cdot \cos \theta \right]; \quad . \quad (1)$$

$$\text{but } n : c = \sin \theta \text{ and } b : c = \cos \theta \quad \therefore$$

$$q=p \sin^2 \theta+p, 2 \sin \theta \cos \theta \quad . \quad . \quad (2)$$

This may be written (see eqs. 63 and 60, O. W. J. Trigonometry)

$$q=p \frac{1}{2}(1-\cos 2\theta)+p, \sin 2\theta \quad . \quad . \quad (3)$$

As the diagonal plane GH is taken in different positions (i.e., as θ varies), this tensile stress q (lbs. per sq. in. for instance) also varies, being a function of θ , and its max. value may be $> p$. To find θ for q max. we put

$$\frac{dq}{d\theta}, =p \sin 2\theta+2p, \cos 2\theta, \quad . \quad . \quad (4)$$

$$=0, \text{ and obtain: } \tan[2(\theta \text{ for } q \text{ max})]=-\frac{2p,}{p} \quad . \quad . \quad (5)$$

Call this value of θ , θ' . Since $\tan 2\theta'$ is negative, $2\theta'$ lies either in the second or fourth quadrant, and hence

$$\sin 2\theta' = \pm \frac{2p,}{\sqrt{p^2+4p,^2}} \quad \text{and} \quad \cos 2\theta' = \mp \frac{p}{\sqrt{p^2+4p,^2}} \quad (6)$$

[See equations 28 and 29 Trigonometry, O. W. J.] The

upper signs refer to the second quadrant, the lower to the fourth. If we now differentiate (4), obtaining

$$\frac{d^2q}{d\theta^2} = 2p \cos 2\theta - 4p_s \sin 2\theta \quad . \quad . \quad (7)$$

we note that if the sine and cosine of the $[2\theta']$ of the 2nd quadrant [upper signs in (6)] are substituted in (7) the result is *negative*, indicating a maximum; that is, q is a maximum for $\theta =$ the θ' of eq. (6) *when the upper signs are taken* (2nd quadrant). To find q max., then, put θ' for θ in (3) substituting from (6) (upper signs). We thus find

$$q \text{ max} = \frac{1}{2} [p + \sqrt{p^2 + 4p_s^2}] \quad . \quad . \quad (8)$$

A similar process, taking components *parallel* to GH , Fig. 273, will yield q_s max., i.e., the max. shear per unit of area, which for a given p and p_s exists on the diagonal plane GH in any of its possible positions, as θ varies. This max. shearing stress is

$$q_s \text{ max} = \frac{1}{2} \sqrt{p^2 + 4p_s^2} \quad . \quad . \quad (9)$$

In the element diametrically opposite to m in Fig. 271, p is compression instead of tension; q maximum will also be compression but is numerically the same as the q max. of eq. 8.

269. Example.—In Fig. 271 suppose $P=2$ tons = 4,000 lbs., $a=6$ in., $l=5$ in., and that the shaft is of wrought iron. Required its radius that the max. tension or compression may not exceed $R'=12,000$ lbs. per sq. in.; nor the max. shear exceed $S'=7,000$ lbs. per sq. in. That is, we put $q=12,000$ in eq. (8) and solve for r : also $q_s=7,000$ in (9) and solve for r . The greater value of r should be taken. From equations (a) and (b) we have (see §§ 219 and 247 for I_p and I)

$$p = \frac{4Pl}{\pi r^3} \text{ and } p_s = \frac{2Pa}{\pi r^3}$$

which in (8) and (9) give

$$\text{max. } q = \frac{1}{2} \frac{P}{\pi r^3} [4l + \sqrt{(4l)^2 + 4(2a)^2}] \quad \dots (8a)$$

and
$$\text{max. } q_s = \frac{1}{2} \frac{P}{\pi r^3} \sqrt{(4l)^2 + 4(2a)^2} \quad \dots (9a)$$

With max. $q=12,000$, and the values of P , a , and l , already given, (units, inch and pound) we have from (8a), $r^3=2.72$ cubic inches $\therefore r=1.39$ inches.

Next, with max. $q_s=7,000$; P , a , and l as before; from (9a), $r^3=2.84$ cubic inches $\therefore r=1.41$ inches.

The latter value of r , 1.41 inches, should be adopted. It is here supposed that the crank-pin is in such a position (when $P=4,000$ lbs., and $a=6$ in.) that q max. (and q_s max.) are greater than for any other position; a number of trials may be necessary to decide this, since P and a are different with each new position of the connecting rod. If the shaft and its connections are exposed to shocks, R and S' should be taken much smaller.

270. Another Example of combined torsion and flexure is

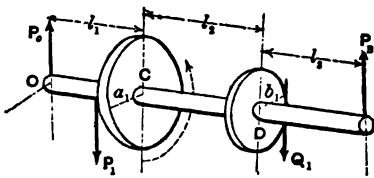

FIG. 274.

shown in Fig. 274. The work of the working force P_1 (vertical cog-pressure) is expended in overcoming the resistance (another vertical cog-pressure) Q_1 .

That is, the rigid body consisting of the two wheels and shaft is employed to transmit power, at a uniform angular velocity, and since it is symmetrical about its axis of rotation the forces acting on it, considered free, form a balanced system. (See § 114). Hence given P_1 and the various geometrical quan-

tities a_1 , b_1 , etc., we may obtain Q_1 , and the reactions P_0 and P_B , in terms of P_1 . The greatest moment of flexure in the shaft will be either P_0l_1 , at C ; or P_Bl_2 , at D . The portion CD is under torsion, of a moment of torsion $= P_1a_1 = Q_1b_1$. Hence we proceed as in the example of § 269, simply putting P_0l_1 (or P_Bl_2 , whichever is the greater) in place of Pl , and P_1a_1 in place of Pa . We have here neglected the weight of the shaft and wheels. If Q_1 were an *upward* vertical force and hence on the same side of the shaft as P_1 , the reactions P_0 and P_B would be less than before, and one or both of them might be reversed in direction.

CHAPTER IV.

FLEXURE, CONTINUED.

CONTINUOUS GIRDERS.

271. **Definition.**—A continuous girder, for present purposes, may be defined to be a loaded straight beam supported in *more than two points*, in which case we can no longer, as heretofore, determine the reactions at the supports from simple Statics alone, but must have recourse to the equations of the several elastic curves formed by its neutral line, which equations involve directly or indirectly the reactions sought; the latter may then be found as if they were constants of integration. Practically this amounts to saying that the reactions depend on the manner in which the beam bends; whereas in previous cases, with only two supports, the reactions were independent of the forms of the elastic curves (the flexure being slight, however).

As an **Illustration**, if the straight beam of Fig. 275 is placed on three supports O , B , and C , at the same level, the reactions of these supports seem at first sight indeterminate; for on considering the whole beam free, we have three unknown quantities and only two equations, viz: Σ (vert. comps.) = 0 and Σ (moms. about some point) = 0. If now O be gradually lowered, it receives less and less pres-

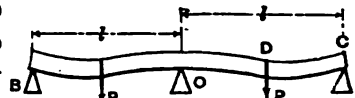

FIG. 275.

sure, until it finally reaches a position where the beam barely touches it; and then O 's reaction is zero, and B and C support the beam as if O were not there. As to how low O must sink to obtain this position, depends on the stiffness and load of the beam. Again, if O be raised above the level of B and C it receives greater and greater pressure, until the beam fails to touch one of the other supports. Still another consideration is that if the beam were tapering in form, being stiffest at O , and pointed at B and C , the three reactions would be different from their values for a prismatic beam. It is therefore evident that for more than two supports the values of the reactions depend on the relative heights of the supports and upon the form and elasticity of the beam, as well as upon the load. The circumstance that the beam is made *continuous* over the support O , instead of being cut apart at O into two independent beams, each covering its own span and having its own two supports, shows the significance of the term "continuous girder."

All the cases here considered will be comparatively simple, from the symmetry of their conditions. The beams will all be prismatic, and all external forces (i.e. loads and reactions) perpendicular to the beam and in the same plane. All supports at the same level.

272. Two Equal Spans; Two Concentrated Loads, One in the Middle of Each Span. Prismatic Beam.—Fig. 275. Let each half-span = $\frac{1}{2}l$. Neglect the weight of the beam. Required the reactions of the three supports. Call them P_B , P_O and P_C . From symmetry $P_B = P_C$, and the tangent to the elastic curve at O is horizontal; and since the supports are on a level the deflection of C (and B) below O 's tangent is zero. The *separate* elastic curves OD and DC have a common slope and a common ordinate at D .

For the equation of OD , make a section n anywhere between O and D , considering nC a free body. Fig. 276 (a)

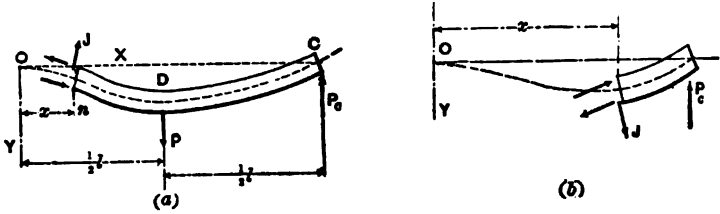

FIG. 276.

with origin and axis as there indicated. From Σ (moms about neutral axis of n) = 0 we have (see § 231)

$$EI \frac{d^2y}{dx^2} = P(\frac{1}{2}l - x) - P_c(l - x) \quad \dots \quad (1)$$

$$\therefore EI \frac{dy}{dx} = P(\frac{1}{2}lx - \frac{x^2}{2}) - P_c(lx - \frac{x^2}{2}) + (C=0) \quad \dots \quad (2)$$

The constant = 0, for at O both x , and $dy \div dx$, = 0.

Taking the x -anti-derivative of (2) we have

$$EIy = P(\frac{lx^2}{4} - \frac{x^3}{6}) - P_c[\frac{lx^2}{2} - \frac{x^3}{6}] \quad \dots \quad (3)$$

Here again the constant is zero since at O , x and y both = 0. (3) is the equation of OD , and allows no value of $x < 0$ or $x > \frac{1}{2}l$. It contains the unknown force P_c .

For the equation of DC , let the variable section n be made anywhere between D and C , and we have (Fig. 276 (b); x may now range between $\frac{1}{2}l$ and l)

$$EI \frac{d^2y}{dx^2} = -P_c(l - x) \quad \dots \quad (4)$$

$$\therefore EI \frac{dy}{dx} = -P_c(lx - \frac{x^2}{2}) + C' \quad \dots \quad (5')$$

To determine C' , put $x = \frac{1}{2}l$ both in (5)' and (2), and equate the results (for the two curves have a common tangent line at D) whence $C' = \frac{1}{8} P l^2$

$$\therefore EI \frac{dy}{dx} = \frac{1}{8} P l^2 - P_c(lx - \frac{x^2}{2}) \quad \dots \quad (5)$$

$$\text{Hence } EIy = \frac{1}{8} P l^2 x - P_c \left[\frac{l x^2}{2} - \frac{x^3}{6} \right] + C'' \quad . \quad . \quad (6')$$

At *D* the curves have the same *y*, hence put $x = \frac{l}{2}$ in the right hand member both of (3) and (6)', equating results, and we derive $C'' = -\frac{1}{48} P l^3$

$$\therefore EIy = \frac{1}{8} P l^2 x - P_c \left[\frac{l x^2}{2} - \frac{x^3}{6} \right] - \frac{1}{48} P l^3 \quad . \quad . \quad (6)$$

which is the equation of *DC*, but contains the unknown reaction P_c . To determine P_c we employ the fact that *O*'s tangent passes through *C*, (supports on *same level*) and hence when $x = l$ in (6), *y* is known to be zero. Making these substitutions in (6) we have

$$0 = \frac{1}{8} P l^3 - \frac{1}{3} P_c l^3 - \frac{1}{48} P l^3 \therefore P_c = \frac{5}{16} P$$

From symmetry P_B also $= \frac{5}{16} P$, while P_0 must $= \frac{2}{16} P$, since $P_B + P_0 + P_c = 2 P$ (whole beam free). [NOTE.— If the supports were not on a level, but if, (for instance) the middle support *O* were a small distance $= h_0$ below the level line joining the others, we should put $x = l$ and $y = -h_0$ in eq. (6), and thus obtain $P_B = P_c = \frac{5}{16} P + 3EI \frac{h_0}{l^3}$, which depends on the material and form of the prismatic beam and upon the length of one span, (whereas with supports *all on a level*, $P_B = P_c = \frac{5}{16} P$ is independent of the material and form of the beam so long as it is homogeneous and prismatic.) If P_0 , which would then $= \frac{2}{16} P - 6EI (h_0 \div l^3)$, is found to be *negative*, it shows that *O* requires a support from above, instead of below, to cause it to occupy a position h_0 below the other supports, i.e. the beam must be "latched down" at *O*.]

The *moment diagram* of this case can now be easily constructed; Fig. 277. For any free body nC , n lying in *DC*, we have

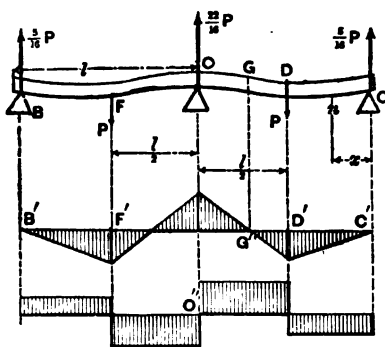

FIG. 277.

$$M = \frac{5}{16}Px,$$

i.e., varies directly as x , until x passes D when, for any point on DO ,

$$M = \frac{5}{16}Px - P(x - \frac{l}{2})$$

which is $= 0$, (point of inflection of elastic curve) for $x = \frac{8}{11}l$ (note that x is measured from C in this

figure) and at O , where $x = l$, becomes $-\frac{6}{32}Pl$

$$\therefore M_o = -\frac{6}{32}Pl; M_G = 0; M_D = \frac{5}{32}Pl; \text{ and } M_c = 0$$

Hence, since M max. $= \frac{6}{32}Pl$, the equation for safe loading is

$$\frac{R'I}{e} = \frac{6}{32}Pl \quad . \quad . \quad . \quad (7)$$

The shear at C and anywhere on $CD = \frac{5}{16}P$, while on DO it $= \frac{11}{16}P$ in the opposite direction

$$\therefore J_m = \frac{11}{16}P \quad . \quad . \quad . \quad (8)$$

The moment and shear diagrams are easily constructed, as shown in Fig. 277, the former being symmetrical about a vertical line through O , the latter about the point O'' . Both are bounded by right lines.

273. Two Equal Spans. Uniformly Distributed Load Over Whole Length. Prismatic Beam.

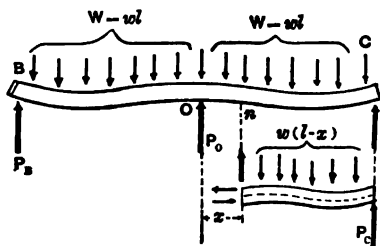

FIG. 278.

—Fig. 278. Supports B, O, C , on a level. Total load $= 2W = 2wl$ and may include that of the beam; w is constant. As before, from symmetry $P_B = P_C$, the unknown reactions at the extremities.

Let $On=x$; then with nC free, Σ moms. about $n=0$ gives

$$EI \frac{d^2y}{dx^2} = w(l-x)\left(\frac{l-x}{2}\right) - P_c(l-x) - \frac{w}{2} [l^2 - 2lx + x^2] - P_c(l-x) \quad (1)$$

$$\therefore EI \frac{dy}{dx} = \frac{w}{2} \left[lx - lx^2 + \frac{x^3}{3} \right] - P_c \left[lx - \frac{x^2}{2} \right] + [\text{Const}=0] \quad (2)$$

[Const.=0 for at O both $dy \div dx$ the slope, and x , are =0]

$$\therefore EIy = \frac{w}{2} \left[\frac{1}{2}lx^2 - \frac{1}{3}lx^3 + \frac{1}{12}x^4 \right] - P_c \left[\frac{1}{2}lx^2 - \frac{1}{6}x^3 \right] + (C=0) \quad (3)$$

[Const.=0 for at O both x and y are =0]. Equations (1), (2), and (3) admit of any value of x from 0 to l , i.e., hold good for any point of the elastic curve OC , the loading on which follows a continuous law (viz.: $w = \text{constant}$). But when $x=l$, i.e., at C , y is known to be equal to zero, since O, B and C are on the axis of X , (tangent at O). With these values of x and y in eq. (3) we have

$$0 = \frac{w}{2} \cdot \frac{l^4}{4} - \frac{1}{3} P_c l^3 \therefore P_c = \frac{3}{8} wl = \frac{3}{8} W$$

$$\therefore P_B = \frac{3}{8} W \text{ and } P_0 = 2W - 2P_c = \frac{10}{8} W$$

The Moment and Shear Diagrams can now be formed since

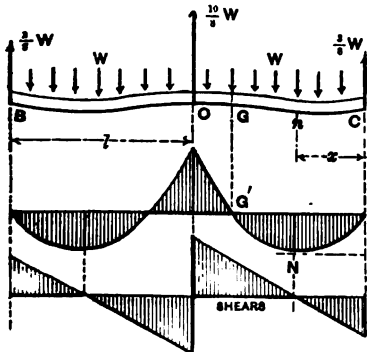

FIG. 279.

all the external forces are known. In Fig. 279 measure x from C . Then in any section n the moment of the "stress-couple" is

$$M = \frac{3}{8} Wx - \frac{wx^2}{2} \quad (1)$$

which holds good for any value of x on CO , i.e., from $x=0$ up to $x=l$. By inspection it is seen that for $x=0$,

$M=0$; and also for $x=3/4l$, $M=0$, at the inflection point G , beyond which, toward O , the upper fibres are in tension

the lower in compression, whereas between C and G they are vice versâ. As to the greatest moment to be found on CG , put $dM+dx=0$ and solve for x . This gives

$$\frac{3}{8}W - wx = 0 \therefore [x \text{ for } M \text{ max.}] = \frac{3}{8}l \quad . \quad (2)$$

which in eq. (1) gives

$$M_N \text{ (at } N, \text{ see figure)} = +\frac{9}{128}Wl \quad . \quad . \quad (2)$$

But this is numerically less than $M_o (= -\frac{1}{8}Wl)$ hence the stress in the outer fibre at O being

$$p_o = \frac{1}{8} \frac{Wle}{I}, \quad . \quad . \quad . \quad (3)$$

the equation for safe loading is

$$\frac{BI}{e} = \frac{1}{8}Wl \quad . \quad . \quad . \quad (4)$$

the same as if the beam were cut through at O , each half, of length l , retaining the same load as before [see § 242 eq. (2)]. Hence making the girder continuous over the middle support does not make it any stronger under a uniformly distributed load; but it does make it considerably *stiffer*.

As for the shear, J , we obtain it for any section by taking the x -derivative of M in eq. (1), or by putting $\Sigma(\text{vertical forces}) = 0$ for the free body nC , and thus have for any section on CO

$$J = \frac{3}{8}W - wx \quad . \quad . \quad . \quad (5)$$

J is zero for $x = \frac{3}{8}l$ (where M reaches its calculus maximum M_N ; see above) and for $x=l$ it is $-\frac{5}{8}W$ which is numerically greater than $\frac{3}{8}W$, its value at C . Hence

$$J_m = \frac{5}{8}W \quad . \quad . \quad . \quad (6)$$

The moment curve is a parabola (a separate one for each span), the shear curve a straight line, inclined to the horizontal, for each span.

Problem.—How would the reactions in Fig. 278 be changed if the support O were lowered a (small) distance h_0 below the level of the other two?

274. Prismatic Beam Fixed Horizontally at Both Ends (at Same Level). Single Load at Middle.—Fig. 280. [As usual

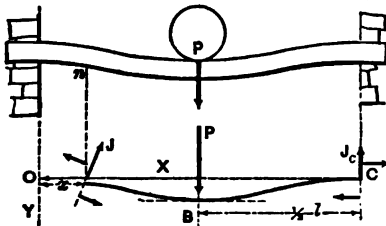

FIG. 280.

the beam is understood to be homogeneous so that E is the same at all sections]. The building in, or fixing, of the two ends is supposed to be of such a nature as to cause *no horizontal constraint*; i.e., the beam does

not act as a cord or chain, in any manner, and hence the sum of the horizontal components of the stresses in any section is zero, as in all preceding cases of flexure. In other words the neutral axis still contains the centre of gravity of the section and the tensions and compressions are equivalent to a couple (the stress-couple) whose moment is the "moment of flexure."

If the beam is conceived cut through close to both wall faces, and this portion of length= l , considered free, the forces holding it in equilibrium consist of the downward force P (the load); two upward shears J_0 and J_c (one at each section); and two "stress-couples" one in each section, whose moments are M_0 and M_c . From symmetry we know that $J_0=J_c$, and that $M_0=M_c$. From $\Sigma Y=0$ for the free body just mentioned, (but not shown in the figure), and from symmetry, we have $J_0=\frac{1}{2} P$ and $J_c=\frac{1}{2} P$; but to determine M_0 and M_c , the form of the elastic curves OB and BC must be taken into account as follows:

Equation of OB , Fig. 280. Σ [mom. about neutral axis of any section n on OB] = 0 (for the free body nC which

has a section exposed at each end, n being the variable section) will give

$$EI \frac{d^2y}{dx^2} = P(\frac{1}{2}l - x) + M_c - \frac{1}{2}P(l - x) \dots (1)$$

[Note. In forming this moment equation, notice that M_c is the sum of the moments of the tensions and compressions at C about the neutral axis at n , just as much as about the neutral axis of C ; for those tensions and compressions are equivalent to a couple, and hence the sum of their moments is the same taken about any axis whatever \perp to the plane of the couple (§32).]

Taking the x -anti-derivative of each member of (1),

$$EI \frac{dy}{dx} = P(\frac{1}{2}lx - \frac{1}{2}x^2) + M_c x - \frac{1}{2}P(lx - \frac{1}{2}x^2) \dots (2)$$

(The constant is not expressed, as it is zero). Now from symmetry we know that the tangent-line to the curve OB at B is horizontal, i.e., for $x = \frac{1}{2}l$, $dy \div dx = 0$, and these values in eq. (2) give us

$$0 = \frac{1}{8}Pl^2 + \frac{1}{2}M_c l - \frac{3}{16}Pl^2; \text{ whence } M_c = M_0 = \frac{1}{8}Pl \dots (3)$$

Safe Loading. Fig. 281. Having now all the forces which act as external forces in straining the beam OC , we are ready to draw the moment diagram and find M_m . For convenience measure x from C . For the free body nC , we have [see eq. (3)]

$$\frac{1}{2}Px - M_c + \frac{Pl}{e} = 0 \therefore M = \frac{1}{8}Pl - \frac{1}{2}Px \dots (4)$$

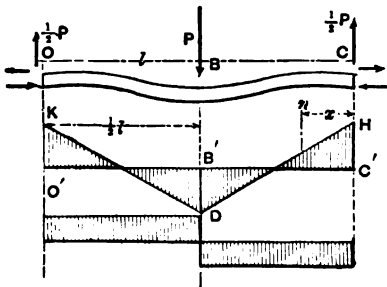

FIG. 281.

Eq. (4) holds good for any section on CB . By putting $x=0$ we have $M = M_c = \frac{1}{8}Pl$; lay off $HC' = M_c$ to scale (so many inch-pounds moment to the inch of paper). At B , for $x = \frac{1}{2}l$, $M = -\frac{1}{8}Pl$; hence lay off $B'D = \frac{1}{8}Pl$ on the opposite side of the axis $O'C'$

from HC' , and join DH . DK , symmetrical with DH about $B'D$, completes the moment curves, viz.: two right lines. The max. M is evidently $=\frac{1}{8} Pl$ and the equation of safe loading

$$\frac{R'I}{e} = \frac{1}{8} Pl \dots \dots \dots (5)$$

Hence the beam is twice as strong as if simply supported at the ends, under this load; it may also be proved to be four times as stiff.

The points of inflection of the elastic curve are in the middles of the half-spans, while the max. shear is

$$J_m = \frac{1}{2} P \dots \dots \dots (6)$$

275. Prismatic Beam Fixed Horizontally at Both Ends [at Same Level]. Uniformly Distributed Load Over the Whole Length. Fig. 282. As in the preceding problem, we know from symmetry that $J_0 = J_c = \frac{1}{2} W = \frac{1}{2} wl$, and that $M_0 = M_c$, and determine the latter quantities by the equation of the curve OC , there being but one curve in the present instance, instead of two, as there is no change in the law of loading between O and C . With nO free, $\Sigma (\text{mom}_n) = 0$ gives

$$EI \frac{d^2y}{dx^2} = -\frac{1}{2} Wx + M_0 + \frac{wx^2}{2} \dots \dots (1)$$

and $\therefore EI \frac{dy}{dx} = -\frac{1}{2} W \frac{x^2}{2} + M_0 x + \frac{wx^3}{6} + [C = 0] \dots (2)$

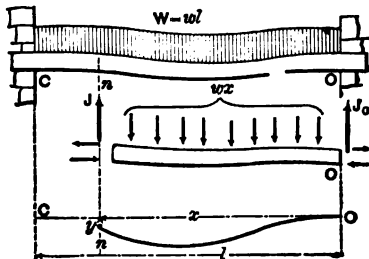

FIG. 282.

The tangent line at O being horizontal we have for $x=0, \frac{dy}{dx} = 0, \therefore C=0$. But since the tangent line at C is also horizontal, we may for $x=l$ put $dy+dx=0$, and obtain

$$0 = -\frac{1}{4} Wl^2 + M_0 l + \frac{1}{6} wl^3; \text{ whence } M_0 = \frac{1}{12} Wl \dots (3)$$

as the moment of the stress-couple close to the wall at O and at C .

Hence, Fig. 283, the equation of the moment curve (a single continuous curve in this case) is found by putting $\sum (\text{mom}_n) = 0$ for the free body nO , of length x , thus obtaining

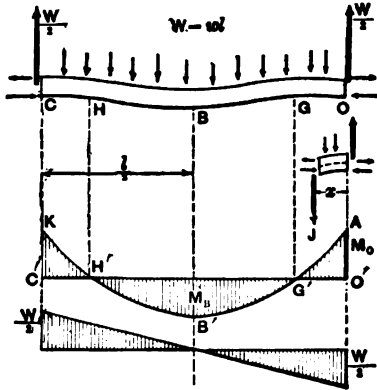

FIG. 283.

$$\frac{px^2}{e} + \frac{1}{2} Wx - M_0 - \frac{wx^3}{2} = 0$$

i.e.,
$$M = \frac{1}{12} Wl + \frac{wx^2}{2} - \frac{1}{2} Wx \dots (4)$$

an equation of the second degree, indicating a conic. At $O, M = M_0$ of course, $= \frac{1}{12} Wl$; at B by putting $x = \frac{1}{2} l$ in (4), we have $M_B = -\frac{1}{24} Wl$, which is less than M_0 , although M_B is the calculus max. (negative) for M , as may be shown by writing the expression for the shear ($J = \frac{1}{2} W - wx$) equal to zero, etc.

Hence $M_m = \frac{1}{12} Wl$, and the equation for *safe loading* is

$$\frac{R'I}{e} = \frac{1}{12} Wl \dots \dots \dots (5)$$

Since (with this form of loading) if the beam were not built in but simply rested on two end supports, the equation for safe loading would be $[R'I + e] = \frac{1}{6} Wl$, (see §242), it is evident that with the present mode of support it is 50 per cent. stronger as compared with the other; i.e., as regards normal stresses in the outer elements. As regards shearing stresses in the web if it has one, it is no stronger, since $J_m = \frac{1}{2} W$ in both cases.

As to *stiffness* under the uniform load, the max. deflection in the present case may be shown to be only $\frac{1}{6}$ of that in the case of the simple end supports.

It is noteworthy that the shear diagram in Fig. 283 is identical with that for simple end supports §242, under uniform load; while the moment diagrams differ as follows: The parabola $KB'A$, Fig. 283, is identical with that in Fig. 235, but the horizontal axis from which the ordinates of the former are measured, instead of joining the extremities of the curve, cuts it in such a way as to have equal areas between it and the curve, on opposite sides

$$\text{i.e., areas } [KC'H' + AG'O'] = \text{area } H'G'B'$$

In other words, the effect of fixing the ends horizontally is to shift the moment parabola upward a distance = M_e (to scale), = $\frac{1}{12} Wl$, with regard to the axis of reference, $O'B'$, in Fig. 235.

276. Remarks.—The foregoing very simple cases of continuous girders illustrate the means employed for determining the reactions of supports and eventually the max. moment and the equations for safe loading and for deflections. When there are more than three supports, with spans of unequal length, and loading of any description, the analysis leading to the above results is much more complicated and tedious, but is considerably simplified

and systematized by the use of the remarkable theorem of three moments, the discovery of Clapeyron, in 1857. By this theorem, given the spans, the loading, and the vertical heights of the supports, we are enabled to write out a relation between the moments of each three consecutive supports, and thus obtain a sufficient number of equations to determine the moments at all the supports [p. 641 Rankine's Applied Mechanics.] From these moments the shears close to each side of each support are found, then the reactions, and from these and the given loads the moment at any section can be determined; and hence finally the max. moment M_m , and the max. shear J_m .

The treatment of the general case of continuous girders by graphic methods, however, is comparatively simple, and its presentation is therefore deferred, § 391.

THE DANGEROUS SECTION OF NON-PRISMATIC BEAMS.

277. Remarks. By "*dangerous section*" is meant that section (in a given beam under given loading with given mode of support) where p , the normal stress in the outer fibre, at distance e from its neutral axis, is greater than in the outer fibre of any other section. Hence the elasticity of the material will be first impaired in the outer fibre of this section, if the load is gradually increased in amount (but not altered in distribution).

In all preceding problems, the beam being prismatic, I , the moment of inertia, and e were the same in all sections, hence when the equation $\frac{pI}{e} = M$ [§239] was solved for p ,

giving
$$p = \frac{Me}{I} \quad . \quad . \quad . \quad . \quad (1)$$

we found that p was a max., = p_m , for that section whose M was a maximum, since p varied as M , for the moment

of the stress-couple, as successive sections along the beam were examined.

But for a non-prismatic beam I and e change, from section to section, as well as M , and the ordinate of the moment diagram no longer shows the variation of p , nor is p a max. where M is a max. To find the dangerous section, then, for a non-prismatic beam, we express the M , the I , and the e of any section in terms of x , thus obtaining $p = \text{func.}(x)$, then writing $dp + dx = 0$, and solving for x .

278. Dangerous Section in a Double Truncated Wedge. Two End Supports. Single Load in Middle.—The form is shown in Fig. 284. Neglect weight of beam; measure x from one support O .

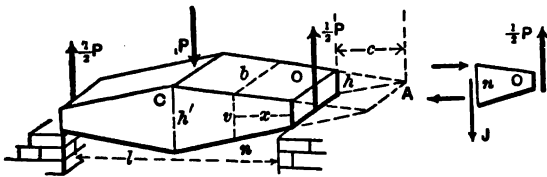

FIG. 284.

The reaction at each support is $\frac{1}{2} P$. The width of the beam = b at

all sections, while its height, v , varies, being = h at O . To express the $e = \frac{1}{2} v$, and the $I = \frac{1}{12} b v^3$ (§247) of any section on OC , in terms of x , conceive the sloping faces of the truncated wedge to be prolonged to their intersection A , at a known distance = c from the face at O . We then have from similar triangles

$$v : x + c :: h : c, \therefore v = \frac{h}{c} (x + c) \quad \dots (1)$$

$$\text{and } \therefore e = \frac{1}{2} \frac{h}{c} (x + c) \text{ and } I = \frac{1}{12} b \frac{h^3}{c^3} [x + c]^3 \quad \dots (2)$$

For the free body nO , Σ (mom_s) = 0 gives

$$\frac{1}{2} P x - \frac{p I}{e} = 0 \therefore p = \frac{P x e}{2 I} \quad \dots (3)$$

[That is, the $M = \frac{1}{2} P x$.] But from (2), (3) becomes

$$p = 3P \frac{c^2}{b h^3} \cdot \frac{x}{(x + c)^3}; \text{ and } \frac{dp}{dx} = 3P \frac{c^2}{b h^3} \cdot \frac{(x + c)^2 - 2x(x + c)}{(x + c)^4} \quad (4)$$

By putting $dp + dx = 0$ we obtain both $x = -c$, and

$x = +c$, of which the latter, $x = +c$, corresponds to a maximum for p (since it will be found to give a negative result on substitution in $d^2p + dx^2$).

Hence the dangerous section is as far from the support O , as the imaginary edge, A , of the completed wedge, but of course on the opposite side. This supposes that the half-span, $\frac{1}{2}l$, is $> c$; if not, the dangerous section will be at the middle of the beam, as if the beam were prismatic.

Hence, with $\frac{1}{2}l < c$ $\left\{ \begin{array}{l} \text{the equation for safe} \\ \text{loading is: } (h' = \text{height} \\ \text{at middle)} \end{array} \right\} \frac{R'b h'^2}{6} = \frac{1}{4} Pl \quad (5)$

while with $\frac{1}{2}l > c$ $\left\{ \begin{array}{l} \text{the equation for safe} \\ \text{loading is: (put } x=c \\ \text{and } p=R' \text{ in [3])} \end{array} \right\} \frac{R'b [2h]^2}{6} = \frac{1}{2} Pc \quad (6)$

(see §239.)

279. Double Truncated Pyramid and Cone. Fig. 285. For

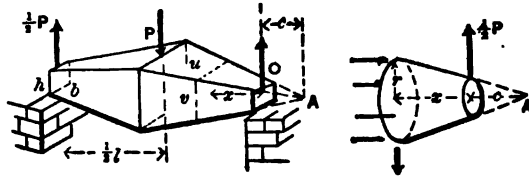

FIG. 285.

the truncated pyramid both width = u , and height = v , are variable, and if b and h are the dimensions at O , and $c = \overline{OA}$ = distance from O to the imaginary vertex A , we

shall have from similar triangles $u = \frac{b}{c}(x+c)$ and $v = \frac{h}{c}(x+c)$.

Hence, substituting $e = \frac{1}{2}v$ and $I = \frac{1}{12} uv^2$, in the moment equation

$$\frac{pI}{e} - \frac{Px}{2} = 0, \text{ we have } p = 3P \frac{c^2}{bh^2} \cdot \frac{x}{(x+c)^3} \dots (7)$$

$$\therefore \frac{dp}{dx} = 3P \frac{c^2}{bh^2} \cdot \frac{(x+c)^2 - 3x(x+c)^2}{(x+c)^6} \dots (8)$$

Putting this = 0, we have $x = -c$, $x = -c$, and $x = +\frac{1}{2}c$, hence the dangerous section is at a distance $x = \frac{1}{2}c$ from O , and the equation for safe loading is

$$\text{either } \frac{R'b'h^2}{6} = \frac{1}{4} Pl \dots \text{ if } \frac{1}{2} l \text{ is } < \frac{1}{2} c \dots (9)$$

(in which b' and h' are the dimensions at mid-span)

$$\text{or } \frac{R(\frac{3}{2}b)(\frac{3}{2}h)^2}{6} = \frac{1}{4} Pc \text{ if } \frac{1}{2} l \text{ is } > \frac{1}{2} c \dots (10)$$

For the truncated cone (see Fig. 285 also, on right) where $e =$ the variable radius r , and $I = \frac{1}{4} \pi r^4$, we also have

$$p = [\text{Const.}] \cdot \frac{x}{(x+c)^3} \dots (11)$$

and hence p is a max. for $x = \frac{1}{2}c$, and the equation for safe loading

$$\text{either } \frac{\pi R' r^3}{4} = \frac{1}{4} Pl, \text{ for } \frac{1}{2} l < \frac{1}{2} c \dots (12)$$

(where r' = radius of mid-span section);

$$\text{or } \frac{\pi R' (\frac{3}{2}r_0)^3}{4} = \frac{1}{4} Pc, \text{ for } \frac{1}{2} l > \frac{1}{2} c \dots (13)$$

(where r_0 = radius of extremity.)

NON-PRISMATIC BEAMS OF "UNIFORM STRENGTH."

280. Remarks. A beam is said to be of "*uniform strength*" when its form, its mode of support, and the distribution of loading, are such that the normal stress p has the same value in all the outer fibres, and thus one element of economy is secured, viz.: that all the outer fibres may be made to do full duty, since under the safe loading, p will be = to R' in all of them. [Of course, in all cases of flexure, the elements between the neutral surface and

the outer fibres being under tensions and compressions less than R' per sq. inch, are not doing full duty, as regards economy of material, unless perhaps with respect to shearing stresses.] In Fig. 265, §261, we have already had an instance of a body of uniform strength in flexure, viz.: the middle segment, CD , of that figure; for the moment is the same for all sections of CD [eq. (2) of that §], and hence the normal stress p in the outer fibres (the beam being prismatic in that instance).

In the following problems the weight of the beam itself is neglected. The general method pursued will be to find an expression for the outer-fibre-stress p , at a definite section of the beam, where the dimensions of the section are known or assumed, then an expression for p in the variable section, and equate the two. For clearness the figures are exaggerated, vertically.

281. Parabolic Working Beam. Unsymmetrical. Fig. 286

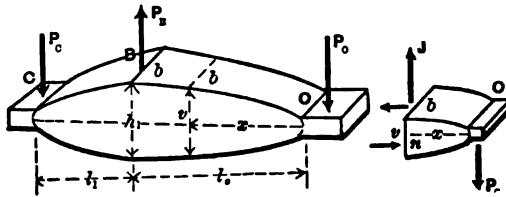

FIG. 286.

CBO is a working beam or lever, B being the fixed fulcrum or bearing. The force P_o being given we may compute P_c from the mom. equation $P_o l_o = P_c l_1$, while the fulcrum reaction is $P_B = P_o + P_c$. All the forces are \perp to the beam. The beam is to have the same width b at all points, and is to be *rectangular* in section.

Required first, the proper height h_1 , at B , for safety. From the free body BO , of length = l_o , we have Σ (moments) = 0; i.e.,

$$\frac{p_B I}{e} = P_o l_o; \text{ or } p_B = \frac{6 P_o l_o}{b h_1^3} \dots (1)$$

Hence, putting $p_B = R'$, h_1 becomes known from (1).

Required, **secondly**, the relation between the variable height v (at any section n) and the distance x of n from O . For the free body nO , we have ($\Sigma \text{ mom}_{S_n} = 0$)

$$\frac{p_n I}{e} = P_o x; \text{ or } \frac{p_n \frac{1}{12} b v^3}{\frac{1}{2} v} = P_o x \text{ and } \therefore p_n = \frac{6 P_o x}{b v^2} \quad (2)$$

But for "uniform strength" p_n must = p_B ; hence equate their values from (1) and (2) and we have

$$\frac{x}{v^2} = \frac{l_o}{h_1^2}, \text{ which may be written } (\frac{1}{2} v)^2 = \frac{(\frac{1}{2} h_1)^2}{l_o} x \quad (3)$$

so as to make the relation between the abscissa x and the ordinate $\frac{1}{2} v$ more marked; it is the equation of a parabola, whose vertex is at O .

The parabolic outline for the portion BC is found similarly. The local stresses at C , B , and O must be properly provided for by evident means. The shear $J = P_o$, at O , also requires special attention.

This shape of beam is often adopted in practice for the working beams of engines, etc.

The parabolic outlines just found may be replaced by trapezoidal forms, Fig. 287, without using much more material, and by making the sloping plane faces tangent to the parabolic outline at points T_0 and T_1 , half-way between O and B , and C and B , respectively. It

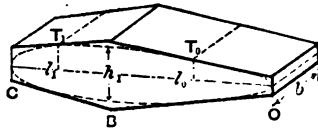

FIG. 287.

can be proved that they contain *minimum volumes*, among all trapezoidal forms capable of circumscribing the given parabolic bodies. The dangerous sections of these trapezoidal bodies are at the tangent points T_0 and T_1 . This is as it should be, (see § 278), remembering that the subtangent of a parabola is bisected by the vertex.

282. I-Beam of Uniform Strength.—Support and load same as in the preceding §. Fig. 288. Let the area of the

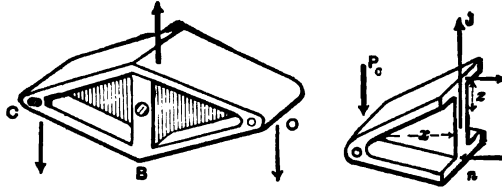

FIG. 288.

flange-sections be = F and let it be the *same* for all values of x . Considering all points of F at any one section as at the same distance z from the neutral axis, we may write $I = z^2 F$, and assuming that the flanges take all the tension and compression while the (thin) web carries the shear, the free body of length x in Fig. 288 gives (moms. about n)

$$\frac{pI}{e} = P_c x; \text{ i.e. } \frac{pz^2 F}{z} = P_c x : \text{ or, since } p \text{ is to be constant,}$$

$$z = [\text{Const.}] \cdot x \quad . \quad . \quad . \quad . \quad (1)$$

i. e. z must be made proportional to x .

Hence the flanges should be made *straight*. Practically, if they unite at C , the web takes but little shear.

283. Rectang. Section. Height Constant. Two Supports (at Extremities). Single Eccentric Load.

—Fig. 289. b and h are the dimensions of the section at B . With BO free we have

$$\frac{p_B I_B}{e_B} - P_o l_o = 0 \therefore p_B = \frac{6P_o l_o}{b h^2} \quad (1)$$

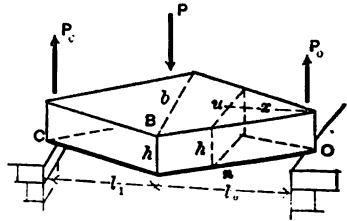

FIG. 289.

At any other section on BO , as n , where the width is u , the variable whose relation to x is required, we have for nO free

$$\frac{p_n I_n}{e_n} = P_o x; \text{ or } \frac{p_n^{1/2} u h^3}{1/2 h} = P_o x \therefore p_n = \frac{6P_o x}{u h^2} \quad . \quad . \quad . \quad (2)$$

Equating p_B and p_n we have $u : b :: x : l_o \quad . \quad . \quad . \quad (3)$

of the distance from the support. The portion *CB* will give corresponding results, referred to the support *C*.

[If the beam in this problem is to have circular cross-sections, let the student treat it in the same manner.]

286. Uniform Load. Two End Supports. Rectangular Cr. Sections. Width Constant. —

Weight of beam neglected. How should the height vary, the height and width at the middle being *h* and *b*? Fig. 289 *b*. From symmetry each reaction = $\frac{1}{2} W = \frac{1}{2} wl$.

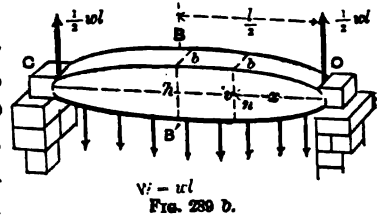

At any cross section *n*, the width is = *b*, (same as that at the middle) and the height = *v*, variable. Σ (moms._{*n*}) = 0, for the free body *nO*, gives

$$\frac{p_n I_n}{e_n} = \frac{1}{2} wl x - \frac{wx^2}{2}; \text{ i.e., } \frac{p_n^1 /_{12} b v^3}{\frac{1}{2} v} = \frac{1}{2} wl x - \frac{wx^2}{2} \dots (1)$$

But for a beam of uniform strength, *p_n* is to be = *p_B* as computed from Σ (moms._{*B*}) = 0 for the free body .. *BO*, i.e from

$$\frac{p_B^1 /_{12} b h^3}{\frac{1}{2} h} = \frac{1}{2} wl \cdot \frac{l}{2} - \frac{w(\frac{1}{2} l)^2}{2} \dots (2)$$

Hence solve (1) for *p_n* and (2) for *p_B* and equate the results,

$$\text{whence } v^2 = \frac{h^2}{(\frac{1}{2} l)^2} [lx - x^2]; \text{ or } (\frac{1}{2} v)^2 = \frac{(\frac{1}{2} h)^2}{(\frac{1}{2} l)^2} [lx - x^2] \dots (3)$$

This relation between the abscissa *x* and the ordinate $\frac{1}{2}v$, of the curve *CBO*, shows it to be an ellipse since eq. (3) is that of an ellipse referred to its principal diameter and the tangent at its vertex as co-ordinate axes.

In this case eq. (3) covers the whole extent of both upper and lower curves, i.e. the complete outline, of the curve *CBOB'*, whereas in Figs. 286, 289, and 289 *a*, such is not the case.

287. **Cantilevers of Uniform Strength.**—Beams built in at one end, horizontally, and projecting from the wall without support at the other, should have the forms given below, for the given cases of loading, if all cross-sections are to be Rectangular and the weight of beam neglected. Sides of sections horizontal and vertical. Also, the sections are symmetrical about the axis of the piece. b and h are the dimensions at the wall. l = length. No proofs given.

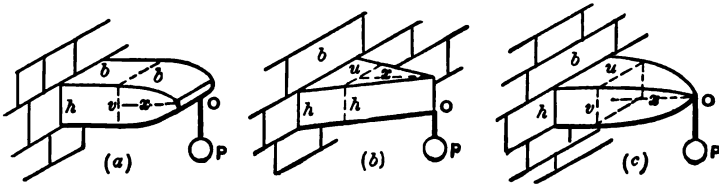

FIG. 290.

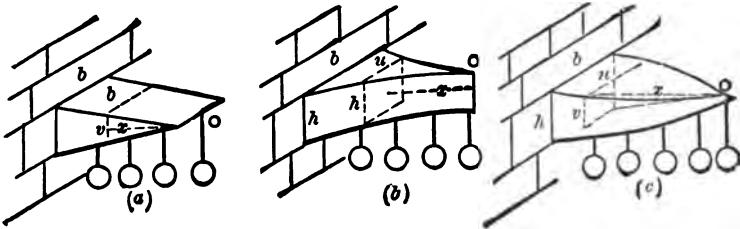

FIG. 291.

Width constant.
Vertical outline parabolic. Single end load. } Fig. 290, (a). $(\frac{1}{2}v)^2 = (\frac{1}{2}h)^2 \frac{x}{l}$ (1)

Height constant.
Single end load. Horizontal outline triangular. } Fig. 290, (b). $(\frac{1}{2}u) = (\frac{1}{2}b) \frac{x}{l}$. (2)

Constant ratio of height v to width u .
Both outlines cubic parabolas. } Fig. 290, (c). $(\frac{1}{2}v)^2 = (\frac{1}{2}h)^2 \frac{x}{l}$. (3)
 $(\frac{1}{2}u)^2 = (\frac{1}{2}b)^2 \frac{x}{l}$. (3)

Uniform Load. Width constant. Vertical outline tri- angular.	}	Fig. 291, (a).	$\left(\frac{1}{2}v\right) = \left(\frac{1}{2}h\right) \frac{x}{l} \quad (4)$
-----------------------------------------------------------------------	---	----------------	-------------------------------------------------------------------------------

Uniform Load. Height constant. Horiz. outline is two parabolas meet- ing at O (vertex) with geomet. axes to wall.	}	Fig. 291, (b).	$\frac{1}{2}u = \left(\frac{1}{2}b\right) \frac{x^2}{l^2} \quad (5)$
------------------------------------------------------------------------------------------------------------------------------------------	---	----------------	----------------------------------------------------------------------

Uniform Load. Both outlines semi- cubic parabolas. Sections similar rectangles.	}	Fig. 291, (c).	$\left(\frac{1}{2}u\right)^2 = \left(\frac{1}{2}b\right)^2 \frac{x^3}{l^3} \quad (6)$
			$\left(\frac{1}{2}v\right)^2 = \left(\frac{1}{2}h\right)^2 \frac{x^3}{l^3} \quad (6')$

289.—Beams and cantilevers of circular cross-sections may be dealt with similarly, and the proper longitudinal outline given, to constitute them “bodies of uniform strength.” As a consequence of the possession of this property, with loading and mode of support of specified character, the following may be stated; that to find the equation of safe loading *any cross-section whatever may be employed*. This refers to tension and compression. As regards the shearing stresses in different parts of the beam the condition of “uniform strength” is not necessarily obtained at the same time with that for normal stress in the outer fibres.

DEFLECTION OF BEAMS OF UNIFORM STRENGTH.

290. Case of § 283, the double wedge, but symmetrical, i.e., $l_1 = l_0 = \frac{1}{2}l$, Fig. 292. Here we shall find the use of the

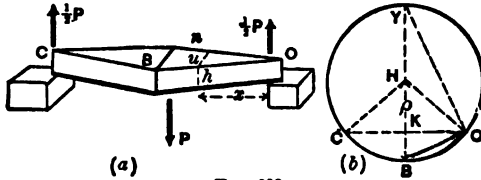

FIG. 292.

form $\frac{EI}{\rho}$ (of the three forms for the moment of the *stress couple*, see eqs. (5), (6) and (7), §§ 229 and 231) of the most direct service in determining the form of the elastic curve OB , which is symmetrical, and has a common tangent at B , with the curve BC . First to find the radius of curvature, ρ , at any section n , we have for the free body nO , $\Sigma(\text{moms.}_n=0)$, whence

$$-\frac{EI}{\rho} + \frac{1}{2}Px = 0; \text{ but } \left\{ \begin{array}{l} \text{from eq.} \\ (3) \text{ § 283} \end{array} \right\} x = \frac{u}{b} \frac{1}{2}l \text{ and } I = \frac{1}{12}uk^3$$

$$\text{we have } \frac{1}{12} \frac{E}{\rho} uk^3 = \frac{1}{4}P \frac{ul}{b} \text{ and } \therefore \rho = \frac{1}{3} \frac{bh^3}{l} \cdot \frac{E}{P} \quad (1)$$

from which all variables have disappeared in the right hand member; i.e., ρ is constant, the same at all points of the elastic curve, hence the latter is the arc of a circle, having a horizontal tangent at B .

To find the deflection, d , at B , consider Fig. 292, (b) where $d = KB$, and the full circle of radius $BH = \rho$ is drawn.

The triangle KOB is similar to YOB ,

$$\text{and } \therefore KB : OB :: OB : YB$$

$$\text{But } OB = \frac{1}{2}l, KB = d \text{ and } YB = 2\rho$$

$$\therefore d = \frac{(\frac{1}{2}l)^2}{2\rho}, \text{ and } \therefore, \text{ from eq. (1), } d = 36 \cdot \frac{P^2}{bh^3E} \quad (2)$$

From eq. (4) §233 we note that for a beam of the same material but *prismatic* (parallelepipedical in this case,) having the same dimensions, b and h , at all sections as at

the middle, deflects an amount $= \frac{1}{48} \frac{P^2}{EI} = \frac{1}{4} \frac{P^2}{bh^3E}$ under a

load P in the middle of the span. Hence the tapering beam of the present § has only $\frac{2}{3}$ the stiffness of the prismatic beam, for the same $b, h, l, E,$ and P .

291. Case of § 281 (Parabolic Body), With $l_1=l_0,$ i.e., Symmetrical.—Fig. 293,(a). Required the equation of the neutral

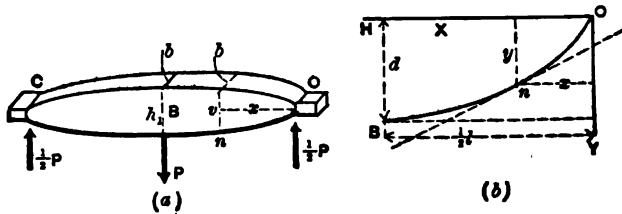

FIG. 293.

line OB . For the free body $nO, \Sigma(\text{mom}_{.n})=0$ gives us

$$EI \frac{d^2y}{dx^2} = -\frac{1}{2}Px \quad \dots \quad (1)$$

Fig. 293, (b), shows simply the geometrical relations of the problem, position of origin, axes, etc. OnB is the neutral line or elastic curve whose equation, and greatest ordinate $d,$ are required. (The right hand member of eq. (1)'' is made negative because $d^2y \div dx^2$ is negative, the curve being concave to the axis X in this, the first quadrant.)

Now if the beam were prismatic, $I,$ the "moment of inertia" of the cross-section would be constant, i.e., the same for all values of $x,$ and we might proceed by taking the x -anti-derivative of each member of (1)'' and add a constant; but it is *variable* and is

$$= \frac{1}{12} b v^3 = \frac{1}{12} \cdot \frac{bh_1^3}{(\frac{1}{2}l)^{\frac{3}{2}}} x^{\frac{3}{2}}, \quad (\text{from eq. 3, § 281, putting } l_0 = \frac{1}{2}l)$$

hence (1)'' becomes

$$\frac{1}{12} E \frac{bh_1^3}{(\frac{1}{2}l)^{\frac{3}{2}}} x^{\frac{3}{2}} \cdot \frac{d^2y}{dx^2} = -\frac{1}{2} Px \quad \dots \quad (1)'$$

To put this into the form $\text{Const.} \times \frac{d^2y}{dx^2} = \text{func. of } (x),$ we need

only divide through by $x^{\frac{3}{2}}$, (and for brevity denote

$\frac{1}{12} Ebh_1^3 \div (\frac{1}{2}l)^{\frac{3}{2}}$ by A) and obtain

$$A \frac{d^2y}{dx^2} = -\frac{1}{2}Px^{-\frac{1}{2}} \dots \dots \dots (1)$$

We can now take the x -anti-derivative of each member, and have

$$A \frac{dy}{dx} = -\frac{1}{2}P(2x^{+\frac{1}{2}}) + C \dots \dots \dots (2)'$$

To determine the constant C , we utilize the fact that at B , where $x = \frac{1}{2}l$, the slope $dy \div dx$ is zero, since the tangent line is there horizontal, whence from (2)'

$$0 = -P\sqrt{\frac{l}{2}} + C \therefore C = P\sqrt{\frac{l}{2}}$$

$$\therefore (2)' \text{ becomes } A \frac{dy}{dx} = P[\sqrt{\frac{l}{2}}l - x^{\frac{1}{2}}] \dots \dots \dots (2)$$

$$\therefore Ay = P [\sqrt{\frac{l}{2}}lx - \frac{2}{3}x^{\frac{3}{2}}] + [C' = 0] \dots \dots \dots (3)$$

($C' = 0$ since for $x = 0, y = 0$). We may now find the deflection d (Fig. 293(b)) by writing $x = \frac{1}{2}l$ and $y = d$, whence, after restoring the value of the constant A ,

$$d = \frac{1}{2} \frac{P^2}{Ebh_1^3} \dots \dots \dots (4)$$

and is twice as great [being $= 2 \cdot \frac{P^2}{4Ebh_1^3}$]* as if the girder

* See § 232, putting $I = \frac{1}{12} bh^3$ in eq. (4).

were parallelepipedical. In other words, the present girder is only half as stiff as the prismatic one.

292. Special Problem. (I.) The symmetrical beam in Fig. 294 is of rectangular cross-section and constant width $= b$,

but the height is constant only over the extreme quarter spans, being $=h_1 = \frac{1}{2}h$, i. e., half the height h at mid-span. The convergence of the two truncated wedges forming the middle quarters of the beam is such that the prolongations

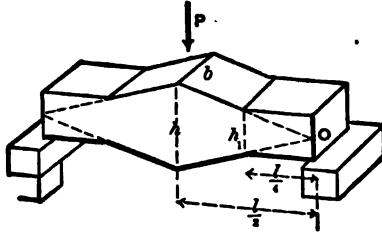

FIG. 294.

of the upper and lower surfaces *would meet over the supports* (as should be the case to make $h=2h_1$). Neglecting the weight of the beam, and placing a single load in middle, it is required to find the equation for safe loading; also the equations of the four elastic curves; and finally the deflection.

The solutions of this and the following problem are left to the student, as exercises. Of course the beam here given is not one of uniform strength.

293. Special Problem. (II). Fig. 295. Required the manner in which the width of the beam must vary, the height being constant, cross-sections rectangular, weight of beam

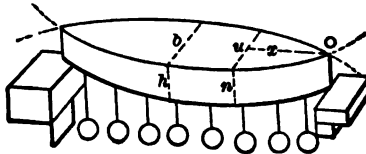

FIG. 295.

neglected, to be a beam of uniform strength, if the load is uniformly distributed?

CHAPTER V.

**FLEXURE OF PRISMATIC BEAMS UNDER
OBLIQUE FORCES.**

294. Remarks. By "oblique forces" will be understood external forces not perpendicular to the beam, but these external forces will be confined to one plane, called the force-plane, which contains the axis of the beam and also cuts the beam symmetrically. The curvature induced by these external forces will as before be considered very slight, so that distances measured along the beam will be treated as unchanged by the flexure.

It will be remembered that in previous problems the proof that the neutral axis of each cross section passes through its centre of gravity, rested on the fact that when a portion of the beam having a given section as one of its bounding surfaces is considered free, the condition of equilibrium $\sum (\text{compons. } \parallel \text{ to beam}) = 0$ does not introduce any of the external forces, since these in the problems referred to, were \perp to the beam; but in the problems of the present chapter such is not the case, and hence the neutral axis does not necessarily pass through the centre of gravity of any section, and in fact may have only an ideal, geometrical existence, being sometimes entirely outside of the section; in other words, the fibres whose ends are exposed in a given section may all be in tension, (or all in compression,) of intensities varying with the distance of each from the neutral axis. It is much more convenient, however, to take for an axis of moments the gravity axis parallel to the

neutral axis instead of the neutral axis itself, since this gravity axis has always a known position.

295. Classification of the Elastic Forces. Shear, Thrust, and Stress-Couple. Fig. 296. Let AKM be one extremity of a portion, considered free, of a prismatic beam, under oblique forces. C is the centre of gravity of the section exposed, and GC the gravity axis \perp to the force plane CAK . The stresses acting on the elements of area (each $=dF$) of the section consist of shears (whose sum $=J$, the "total shear") in the plane of the section and parallel to the force plane, and of normal stress parallel to AK and proportional per unit of area to the distances of the dF 's on which they act from the neutral axis NC'' , real or ideal (ideal in this figure). Imagine the outermost fibre KA , whose distance from the gravity axis is $=e$ and from the neutral axis

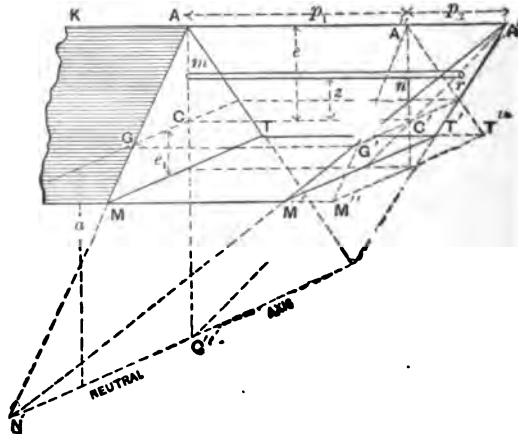

FIG. 296.

$=e + a$, to be prolonged an amount AA' , whose length by some arbitrary scale represents the normal stress (tension or compression) to which the dF at A is subjected. Then, in a plane be passed through A' and the neutral axis NC'' , the lengths, such as mr , parallel to AA' , intercepted between this plane and the section itself, represent the stress-inten-

sities (i. e., per unit area) on the respective dF 's. (In this particular figure these stresses are all of one kind, all tension or all compression; but if the neutral axis occurs within the limits of the section, they will be of opposite kinds on the two sides of NC .) Through C' , the point determined in $A'NC'$ by the intercept CC' of the centre of gravity, pass a plane $A''M''T''$ parallel to the section itself; it will divide the stress-intensity AA' into two parts p_1 and p_2 , and will enable us to express the stress-intensity mr , on any dF at a distance z from the *gravity-axis* GC , in two parts; one part the same for all dF 's, the other dependent on z , thus:

$$[\text{Stress-intensity on any } dF] = p_1 + \frac{z}{e} p_2 \quad \dots (1)$$

and hence the

$$[\text{actual normal stress on any } dF] = p_1 dF + \frac{z}{e} p_2 dF \quad (2)$$

For example, the stress-intensity on the fibre at T , where

$z = -e_1$, will be $p_1 - \frac{e_1}{e} p_2$, and it is now seen how we may find the stress at any dF when p_1 and p_2 have been found. If the distance a , between the neutral and gravity axes is desired, we have, by similar triangles

$$p_2 : e :: C'C : a \text{ whence } a = \frac{p_1}{p_2} \cdot e \quad \dots \dots \dots (3)$$

It is now readily seen, *graphically*, that the stresses or elastic forces represented by the *equal* intercepts between the parallel planes AMT and $A''M''T''$, constitute a uniformly distributed *normal* stress, which will be called the "uniform thrust," or simply the thrust (or pull, as the case may be) of an intensity = p_1 , and \therefore of an amount = $\int p_1 dF =$

$$p_1 \int dF = p_1 F.$$

It is also evident that the positive intercepts forming the

wedge $A''A'G'C'$ and the negative intercepts forming the wedge $M''M'G'C'$ form a system of "graded stresses" whose combination (algebraic) with those of the "thrust" shows the two sets of normal stresses to be equivalent to the actual system of normal stresses represented by the small prisms forming the imaginary solid $AMT \dots A'M'T'$. It will be shown that these graded stresses constitute a "stress-couple."

Analytically, the object of this classification of the normal stresses into a thrust and a stress-couple, may be made apparent as follows :

In dealing with the free body KAM Fig. 296, we shall have occasion to sum the components, parallel to the beam, of all forces acting (external and elastic), also those \perp to the beam; and also sum their moments about some axis \perp to the force plane. Let this axis of moments be GC the gravity-axis of the section (and not the neutral axis); also take the axis $X \parallel$ to the beam and $Y \perp$ to it (and in force-plane). Let us see what part the elastic forces

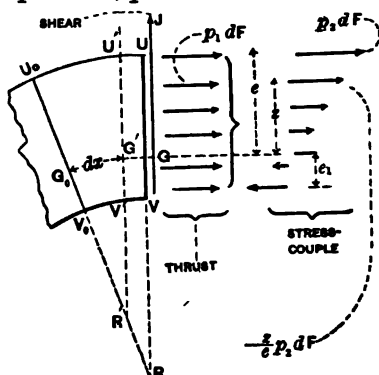

FIG. 297.

will play in these three summations. See Fig. 297, which gives merely a side view. Referring to eq. (2) we see that

$$[\text{The } \Sigma X \text{ of the elastic forces}] = p_1 \int_1^e dF + \frac{p_2}{e} \int_1^e z dF$$

$$\text{i.e. " " " " } = p_1 F + \frac{p_2}{e} F \bar{z}$$

[see eq. (4) § 23]. But as the z 's are measured from G a gravity axis, \bar{z} must be zero. Hence

$$[\text{The } \Sigma X \text{ of the Elastic forces}] = p_1 F \equiv \left\{ \begin{array}{l} \text{the thrust} \\ \text{(or pull)} \end{array} \right\} \quad (4)$$

Also,

[The ΣY of the Elastic forces] = $J \equiv$ the shear; . (5)

while for moments about G [see eq. (1)]

[The Σ (moms._G) of the elastic forces] =

$$\int_1^e (p_1 dF)z + \int_1^e \left(\frac{z}{e} p_2 dF \right)z$$

$$= p_1 \int_1^e z dF + \frac{p_2}{e} \int_1^e z^2 dF$$

and hence finally

$$\left\{ \begin{array}{l} \text{[The } \Sigma \text{ (moms.}_G \text{) of} \\ \text{the Elastic Forces]} \end{array} \right\} = \frac{p_2}{e} I_G = \text{the moment} \quad . . . \quad (6)$$

where $I_G = \int_1^e z^2 dF$, is the "moment of inertia" of

the section about the gravity axis G , (not the neutral axis).

The expression in (6) may be called the moment of the stress-couple, understanding by stress-couple a couple to which the graded stresses of Fig. 297 are equivalent. That these graded stresses are equivalent to a couple is shown by the fact that although they are X forces they do not appear in eq. 4, for ΣX ; hence the sum of the tensions

$$\left[\frac{p_2}{e} \int_0^e z dF \right] \text{ equals that of the compressions } \left[\frac{p_2}{e} \int_1^0 z dF \right]$$

in that set of normal stresses.

We have therefore gained these advantages, that, of the three quantities J (lbs.), p_1 (lbs. per sq. inch), and p_2 (lbs. per sq. inch) a knowledge of which, with the form of the section, completely determines the stresses in the section, equations (4), (5), and (6) contain only one each, and hence algebraic elimination is unnecessary for finding any one of them; and that the axis of reference of the moment of inertia I is the same axis of the section as was used in former problems in flexure.

Another mode of stating eqs. (4), (5) and (6) is this: The sum of the components, parallel to the beam, of the external forces is balanced by the *thrust* or *pull*; those perpen-

dicular to the beam are balanced by the *shear*; while the sum of the moments of the external forces about the gravity axis of the section is balanced by that of the stress-couple. Notice that the thrust can have no moment about the gravity axis referred to.

The Equation for Safe Loading, then, will be this :

$$\left. \begin{array}{l} (a) \quad (p_1 \pm p_2) \text{ max.} \\ \quad \quad \quad \text{or} \\ (b) \quad (p_1 \pm \frac{e_1}{e} p_2) \text{ max.} \end{array} \right\} \begin{array}{l} \text{whichever} \\ \text{is} \\ \text{greater.} \end{array} \quad -R' \quad . \quad . \quad (7)$$

For R' , see table in § 251. The double sign provides for the cases where p_1 and p_2 are of opposite kinds, one tension the other compression. Of course $(p_1 + p_2)$ max is not the same thing as $[p_1 \text{ max.} + p_2 \text{ max.}]$. In most cases in practice $e_1 = e$, and then the part (b) of eq. (7) is unnecessary.

295a. Elastic Curve with Oblique Forces.—(By elastic curve is now meant the locus of the centres of gravity of the sections.) Since the normal stresses in a section differ from those occurring under perpendicular forces only in the addition of a uniform thrust (or pull), whose effect on the short lengths ($=dx$) of fibres between two consecutive sections $U'V'$ and U_0V_0 , Fig. 297, is felt *equally* by all, the location of the centre of curvature R , is not appreciably different from what it would be as determined by the stress-couple alone.

Thus (within the elastic limit), strains being proportional to the stresses producing them, if the forces of the stress-couple acted alone, the length $dx = G_0G'$ of a small portion of a fibre at the gravity axis would remain unchanged, and the lengthening and shortening of the other fibre-lengths between the two sections U_0V_0 and $U'V'$, originally parallel, would occasion the turning of $U'V'$ through a small angle (relatively to U_0V_0) about G' , into the position which it occupies in the figure (297), and G_0R' would be the radius of curvature. But the effect of the uniform pull (added to that of the couple) is to shift $U'V'$ parallel to itself into the position UV , and hence the radius of curvature of the

elastic curve, of which G_0G is an element, is G_0R instead of G_0R' . But the difference between G_0R and G_0R' is very small, being the same, *relatively*, as the difference between $\overline{G_0G}$ and $\overline{G_0G'}$; for instance, with wrought-iron, even if p , the intensity of the uniform pull, were as high as 22,000 lbs. per sq. in. [see § 203] $\overline{G_0G}$ would exceed $\overline{G_0G'}$ by only $\frac{1}{12}$ of one per cent. ($=0.0008$); hence by using GR' instead of GR as the radius of curvature ρ , an error is introduced of so small an amount as to be neglected.

But from § 231, eqs. (6) and (7), $\frac{EI}{\rho} = EI \frac{d^2y}{dx^2} = M$, the sum of the moments of the external forces; hence for prismatic beams under oblique forces we may still use

$$\pm EI \frac{d^2y}{dx^2}, (=M) \quad . \quad . \quad . \quad (1)$$

as one form for the Σ (moments) of the elastic forces of the section about the gravity-axis; remembering that the axis X must be taken parallel to beam.

296. Oblique Cantilever with Terminal Load.—Fig. 298. Let l = length. The “fixing” of the lower end of the beam is its only support. Measure x along the beam from O . Let

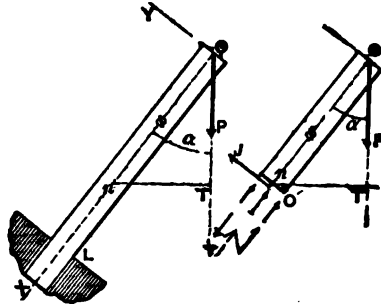

FIG. 298.

FIG. 299.

n be the gravity axis of any section and nT , $=x \sin \alpha$, the length of the perpendicular let fall from n on the line of action of the force P (load). The flexure is so slight that nT is considered to be the same as before the load is al-

lowed to act. [If α were very small, however, it is evident that this assumption would be inadmissible, since then a large proportion of nT would be due to the flexure caused by the load.]

Consider nO free, Fig. 299. In accordance with the preceding paragraph (see eqs. (4), (5), and (6)) the elastic forces of the section consist of a shear J , whose value may be obtained by writing $\sum Y=0$

whence $J = P \sin \alpha; \dots \dots \dots (1)$

of a uniform thrust $= p_1 F$, obtained from $\sum X=0$, viz :

$$P \cos \alpha - p_1 F = 0 \therefore p_1 F = P \cos \alpha; \dots \dots (2)$$

and of a stress-couple whose moment [which we may write either $\frac{p_2 I}{e}$, or $EI \frac{d^2 y}{dx^2}$] is determined from $\sum(\text{moms.}_n)=0$ or

$$\frac{p_2 I}{e} - P x \sin \alpha = 0, \text{ or } \frac{p_2 I}{e} = P x \sin \alpha \dots \dots (3)$$

As to the strength of the beam, we note that the stress-intensity, p_1 , of the thrust is the same in all sections, from O to L (Fig. 298), and that p_2 , the stress-intensity in the outer fibre, (and this is compression if $e=no'$ of Fig. 299) due to the stress-couple is proportional to x ; hence the max. of $[p_1 + p_2]$ will be in the lower outer fibre at L , Fig. 298, where x is as great as possible, $=l$; and will be a compression, viz. :

$$[p_1 + p_2] \text{ max.} = P \left[\frac{\cos \alpha}{F} + \frac{l(\sin \alpha) e}{I} \right] \dots \dots (4)$$

\therefore the equation for Safe Loading is

$$R' = P \left[\frac{\cos \alpha}{F} + \frac{l(\sin \alpha) e}{I} \right] \dots \dots (5)$$

since with $e_1=e$, as will be assumed here, $[p - \frac{e_1}{e} p_1] \text{ max.}$

can not exceed, numerically, $[p_1+p_2]$ max. The stress-intensity in the outer fibres along the upper edge of the beam, being $=p_1-p_2$ (supposing $e_1=e$) will be compressive at the upper end near O , since there p_2 is small, x being small; but lower down as x grows larger, p_2 increasing, a section may be found (before reaching the point L) where $p_2=p_1$ and where consequently the stress in the outer fibre is zero, or in other words the neutral axis of that section passes through the outer fibre. In any section above that section the neutral axis is imaginary, i.e., is altogether outside the section, while below it, it is within the section, but cannot pass beyond the gravity axis. Thus in Fig. 300, $O'L'$

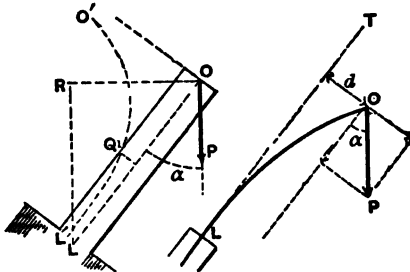

FIG. 300.

FIG. 301.

is the locus of the positions of the neutral axis for successive sections, while OL the axis of the beam is the locus of the gravity axes (or rather of the centres of gravity) of the sections, this latter line forming the "elastic curve" under flexure. As already stated, however, the flexure is to be but slight, and α must not be very small. For instance, if the deflection of O from its position before flexure is of such an amount as to cause the lever-arm OR of P about L to be greater by 10 per cent. than its value ($=l \sin \alpha$) before flexure, the value of p_2 as computed from eq. (3) (with $x=l$) will be less than its true value in the same proportion.

The deflection of O from the tangent at L , by § 237, Fig. 229(a) is $d=(P \sin \alpha)^2 \div 3EI$, approximately, putting $P \sin \alpha$

for the P of Fig. 229 ; but this very deflection gives to the other component, $P \cos a$, \parallel to the tangent at L , a lever arm, and consequent moment, about the gravity axes of all the sections, whence for $\Sigma (\text{moms.}_x) = 0$ we have, (more exactly than from eq. (3) when $x=l$)

$$\frac{p_2 I}{e} = P (\sin a) l + P \cos a \frac{(P \sin a)^2}{3 EI} \dots (6)$$

(We have supposed P replaced by its components \parallel and \perp to the fixed tangent at L , see Fig. 301). But even (6) will not give an exact value for p_2 at L ; for the lever arm of $P \cos a$, viz. d , is $> (P \sin a)^2 + 3EI$, on account of the presence and leverage of $P \cos a$ itself. The true value of d in this case may be obtained by a method similar to that indicated in the next paragraph.

297. Elastic Curve of Oblique Cantilever with Terminal Load. More Exact Solution. For variety place the cantilever as in

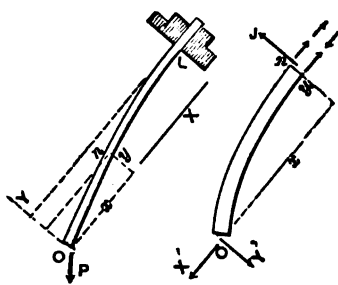

FIG. 302.

FIG. 303.

Fig. 302, so that the deflection $OY=d$ tends to decrease the moment of P about the gravity axis of any section, n . We may replace P by its X and Y components, Fig. 303, \parallel and \perp respectively to the fixed tangent line at L . The origin, O , is taken at the free end of the beam. Let $a =$ angle between P and X .

For a free body On , n being any section, we have $\Sigma (\text{moms.}_n) = 0$

whence
$$EI \frac{d^2 y}{dx^2} = P (\cos a) y - P (\sin a) x \dots (1)$$

[See eq. (1) § 295a]. In this equation the right hand member is evidently (see fig. 303) a negative quantity; this is as it should be, for $EI d^2 y / dx^2$ is negative, the curve being concave to the axis X in the first quadrant. (It must be noted that the axis X is always to be taken \parallel to the beam, for $EI d^2 y / dx^2$ to represent the moment of the stress-couple.)

Eq. (1) is not in proper form for taking the x -anti-derivative of both members, since one term contains the variable y , an unknown function of x . Its integration is included in a more general case given in some works on calculus, but a special solution by Prof. Robinson, of Ohio, is here subjoined for present needs.*

We thus obtain as the equation of the elastic curve in Fig. 303,

$$\sqrt{\frac{P \cos a}{EI}} \left[e_n^x + e_n^{-x} \right] \left[(\sin a)x - (\cos a)y \right] - \sin a \left[e_n^{qx} - e_n^{-qx} \right]. \quad (2)$$

In which e_n denotes the Naperian Base—2.71828, an abstract number, and q for brevity stands for $\sqrt{P \cos a \div EI}$.

To find the deflection d , we make $x=l$ in (2), and solve for y ; the result is d .

The uniform thrust at L is $p_1 F = P \cos a$ (3) while the stress intensity p_2 in the outer fibre at L , is ob-

* Denoting $P \cos a \div EI$ by q^2 and $P \sin a \div EI$ by p^2 , eq. (1) becomes $\frac{d^2 y}{dx^2} = q^2 y - p^2 x$. . . (6)

Differentiate (6) then $\frac{d^3 y}{dx^3} = q^2 \frac{dy}{dx} - p^2$. Differentiate again: whence $\frac{d^4 y}{dx^4} = q^2 \frac{d^2 y}{dx^2}$. (7)

Letting $\frac{d^2 y}{dx^2} = u$. (8) [so that $u = q^2 y - p^2 x$, from (6)] we have $\frac{d^2 u}{dx^2} = \frac{du}{dx}$ and $\frac{d^4 y}{dx^4} = \frac{d^2 u}{dx^2}$

∴ [See (7)] $\frac{d^2 u}{dx^2} = q^2 u$, which, mult. by $2 du$, gives $\frac{1}{dx^2} 2 du du = 2q^2 u du$

∴ (dx constant), $\frac{1}{dx^2} \int 2 du du = 2q^2 \int u du + C$ ∴ $\frac{du^2}{dx^2} = q^2 u^2 + C$. whence

$$dx = \frac{1}{q} \int \sqrt{u^2 + \frac{C}{q^2}} + C^* \text{ l. e. } x = \frac{1}{q} \log_e \left[u + \sqrt{u^2 + \frac{C}{q^2}} \right] - \frac{1}{q} \log_e C, \text{ or, putting}$$

. . . $e_n = \text{Nap. base, } e_n^{\frac{qx}{n}} = \frac{1}{C} \left[u + \sqrt{u^2 + \frac{C}{q^2}} \right]$; or $C^* e_n^{\frac{qx}{n}} u = \sqrt{u^2 + \frac{C}{q^2}}$. . . (9)

Square each side of (9); then $C^2 e_n^{\frac{2qx}{n}} - 2C^* e_n^{\frac{qx}{n}} u + u^2 = u^2 + \frac{C}{q^2}$; ∴ $u = \frac{1}{2} C^* e_n^{\frac{qx}{n}} - \frac{C}{2C^* q^2}$

∴ (see eqs. 6 and 8) $q^2 y - p^2 x = \frac{1}{2} C^* e_n^{\frac{qx}{n}} - \frac{C}{2C^* q^2}$ } which gives y as func. x . Consolidating the

tained from the moment equation for the free body OL

viz:
$$\frac{p_2 l}{e} = P(\sin a)l - P(\cos a) d \dots (4)$$

in which e = distance of outer fibre from the gravity axis.

The equation for safe loading is written out by placing the values of p_1 , p_2 , and d , as derived from equations (2), (3), and (4) in the expression

$$p_1 + p_2 = R'$$

To solve the resulting equation for P , in case that is the unknown quantity, can only be accomplished by successive assumptions and approximations, since it occurs transcendently.

In case a horizontal tension-member of a bridge-truss is subjected to a longitudinal tension P' (due to its position in the truss and the load upon the latter) and at the same time receives a vertical pressure = P'' at the middle, each half will be bent in the same manner as the cantilever in Fig. 302; $\frac{1}{2}P''$ corresponding to $P \sin a$, and P' to $P \cos a$.

constant factors we now write $y = \frac{p^2}{q^2}x + m e_n^{qx} - n e_n^{-qx}$. . . the equation required . (10)

To determine the constants m and n ($m = C + 2q^2$; $n = C + 2C'q^4$) we first find $dy + dx$, i.e.

by differentiating (10) $\frac{dy}{dx} = \frac{p^2}{q^2} + q m e_n^{qx} + q n e_n^{-qx}$ (11) $x=0$ for $y=0$

\therefore (10) gives . . . $0 = 0 + m e_n^0 - n e_n^0 = 0$ i.e. $m - n = 0 \therefore m = n$. (12) Also for $x=l$

$\frac{dy}{dx} = 0 \therefore$ (11) gives $0 = \frac{p^2}{q^2} + q \left[m e_n^{ql} + n e_n^{-ql} \right]$. . (13); \therefore with $n = m$ we have $m = n =$

$-\frac{p^2}{q^2} + q^2 \left[e_n^{ql} + e_n^{-ql} \right]$. . . (14). The equation of the curve, then, substituting (14) in

(10) is $y = \frac{p^2}{q^2} x - \frac{p^2}{q^2} \cdot \frac{e_n^{qx} - e_n^{-qx}}{q l + e_n^{-ql}}$ (15) \therefore , Substituting for p and q we

have, (as in § 297) $\sqrt{\frac{P \cos a}{EI} \left[\frac{q l + e_n^{-ql}}{e_n^{ql} + e_n^{-ql}} \right] \left[x \sin a - y \cos a \right]} = \sin a \left[\frac{e_n^{qx} - e_n^{-qx}}{e_n^{ql} + e_n^{-ql}} \right]$

298. Inclined Beam with Hinge at One End.—Fig. 304. Let $e = e_1$. Required the equation for safe loading; also the maximum shear, there being but one load, P , and that in the middle. The vertical wall being smooth, its reaction,

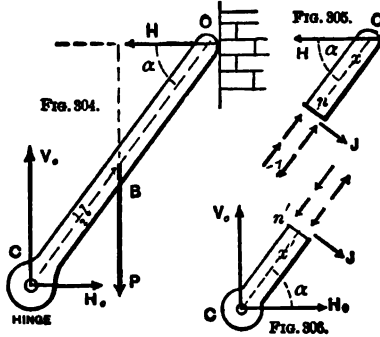

H , at O is horizontal, while that of the hinge-pin being unknown, both in amount and direction, is best replaced by its horizontal and vertical components H_0 and V_0 , unknown in amount only. Supposing the flexure slight, we find these external forces in the same manner as in Prob. 1 § 37, by considering the whole beam free, and obtain

$$H = \frac{P}{2} \cot \alpha; H_0 \text{ also} = \frac{P}{2} \cot \alpha; V_0 = P \quad . \quad . \quad (1)$$

For any section n between O and B , we have, from the free body nO , Fig. 305,

$$\text{uniform thrust} = p_1 F = H \cos \alpha \quad . \quad . \quad (2)$$

and from $\Sigma (\text{moments}) = 0$,

$$\frac{p_2 I}{e} = Hx \sin \alpha \quad (3)$$

$$\text{and the shear} = J = H \sin \alpha = \frac{1}{2} P \cos \alpha \quad (4)$$

The max. $(p_1 + p_2)$ to be found on OB is \therefore close above B , where $x = \frac{1}{2} l$, and is

$$= \frac{H \cos a}{F} + \frac{Hle \sin a}{2I} \text{ which } = P \cos a \left[\frac{\cot a}{2F} + \frac{le}{4I} \right] \quad (5)$$

In examining sections on CB let the free body be Cx' , Fig. 306. Then from Σ (longitud. comps.) = 0

$$(\text{the thrust}) p_1 F = V_0 \sin a + H_0 \cos a \quad (6')$$

$$\text{i.e.} \quad p_1 F = P [\sin a + \frac{1}{2} \cos a \cot a] \quad (6)$$

while, from Σ (moments) = 0,

$$\frac{p_2 I}{e} = V_0 x' \cos a - H_0 x' \sin a \quad (7')$$

$$\text{i.e.} \quad \frac{p_2 I}{e} = \frac{1}{2} P \cos a x' \quad (7)$$

Hence $(p_1 + p_2)$ for sections on CB is greatest when x' is greatest, which is when $x' = \frac{1}{2} l$, x' being limited between $x' = 0$ and $x' = \frac{1}{2} l$, and is

$$(p_1 + p_2) \text{ max. on } CB = P \cos a \left[\frac{\tan a + \frac{1}{2} \cot a}{F} + \frac{1}{4} \frac{le}{I} \right] \quad (8)$$

which is evidently greater than the max. $(p_1 + p_2)$ on BO ; see eq. (5). Hence the equation for safe loading is

$$R' = P \cos a \left[\frac{\tan a + \frac{1}{2} \cot a}{F} + \frac{1}{4} \frac{le}{I} \right] \dots \dots (9)$$

in which R' is the safe normal stress, per square unit, for the material.

The shear, J , anywhere on CB , from Σ (transverse comp.) = 0 in Fig. 306, is

$$J = V_0 \cos a - H_0 \sin a = \frac{1}{2} P \cos a \dots \dots (10)$$

As showing graphically all the results found, *moment*, *thrust*, and *shear* diagrams are drawn in Fig. 307, and also a diagram whose ordinates represent the variation of (p_1+p_2) along the beam. Each ordinate is placed vertically under the gravity axis of the section to which it refers.

299. Numerical Example of the Foregoing.—Fig. 308. Let the beam be of wrought iron, the load $P = 1,800$ lbs., hanging from the middle. Cross section rectangular 2 in. by 1 in., the 2 in. being parallel to the force-plane. Required the max. normal stress in any outer fibre; also the max. total shear.

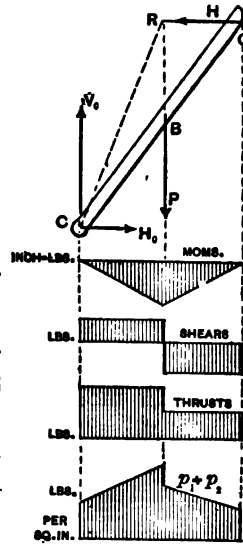

FIG. 307.

This max. stress-intensity will be in the outer fibres in the section just below B and on the upper side, according to § 298, and is given by eq. (8) of that article; in which, see Fig. 308, we must substitute (inch-pound-second-system) $P = 1,800$ lbs.; $F' = 2$ sq. in.; $l = \sqrt{120^2 + 12^2} = 120.6$ in.; $e = 1$ in., $I = \frac{1}{12} bh^3 = \frac{8}{12} = \frac{2}{3}$ biquad. inches; $\cot a = \frac{1}{10}$; $\cos a = .0996$; and $\tan a = 10$.

$$\therefore \max. (p_1+p_2) = 1800 \times .0996 \left[\frac{10 + \frac{1}{20}}{2} + \frac{1}{4} \cdot \frac{120.6 \times 1}{\frac{2}{3}} \right] =$$

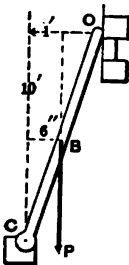

FIG. 308.

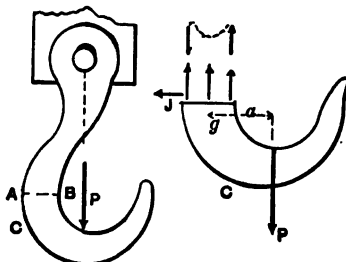

FIG. 309.

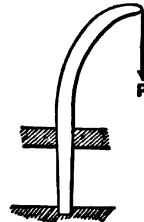

FIG. 310.

9000 lbs. per sq. inch, very nearly, compression. This is in

the upper outer fibre close under B . In the lower outer fibre just under B we have a tension = $p_2 - p_1 = 7,200$ lbs. per sq. in. (It is here supposed that the beam is secure against yielding sideways.)

300. Strength of Hooks.—An ordinary hook, see Fig. 309, may be treated as follows: The load being = P , if we make a horizontal section at AB , whose gravity axis g is the one, of all sections, furthest removed from the line of action of P , and consider the portion C free, we have the shear = $J = \text{zero}$ (1)

$$\text{the uniform pull} = p_1 F = P \quad . \quad . \quad . \quad (2)$$

while the moment of the stress-couple, from $\Sigma (\text{mom.}_x) = 0$, is

$$\frac{p_2 I}{e} = Pa \quad (3)$$

For safe loading $p_1 + p_2$ must = R' , i.e.

$$R' = P \left[\frac{1}{F} + \frac{ae}{I} \right] \quad . \quad . \quad . \quad (4)$$

It is here assumed that $e = e_1$, and that the maximum $[p_1 + p_2]$ occurs at AB .

301 Crane.—As an exercise let the student investigate the strength of a crane, such as is shown in Fig. 310.

CHAPTER VI.

FLEXURE OF "LONG COLUMNS."

302. Definitions.—By "long column" is meant a straight beam, usually prismatic, which is acted on by two compressive forces, one at each extremity, and whose length is so great compared with its diameter that it gives way (or "fails") by buckling sideways, i.e. by flexure, instead of by crushing or splitting like a short block (see § 200). The pillars or columns used in buildings, the compression members of bridge-trusses and roofs, the "bents" of a trestle work, and the piston-rods and connecting-rods of steam-engines, are the principal practical examples of long columns. That they should be weaker than short blocks of the same material and cross-section is quite evident, but their theoretical treatment is much less satisfactory than in other cases of flexure, experiment being very largely relied on not only to determine the physical constants which theory introduces in the formulæ referring to them, but even to modify the algebraic form of those formulæ, thus rendering them to a certain extent empirical.

303. End Conditions.—The strength of a column is largely dependent on whether the ends are free to turn, or are fixed and thus incapable of turning. The former condition is attained by rounding the ends, or providing them with hinges or ball-and-socket-joints; the latter by facing off each end to an accurate plane surface, the bearing on which it rests being plane also, and incapable of turning.

In the former condition the column is spoken of as having round ends; Fig. 311, (a); in the latter as having fixed ends, (or flat bases; or square ends), Fig. 311, (b).

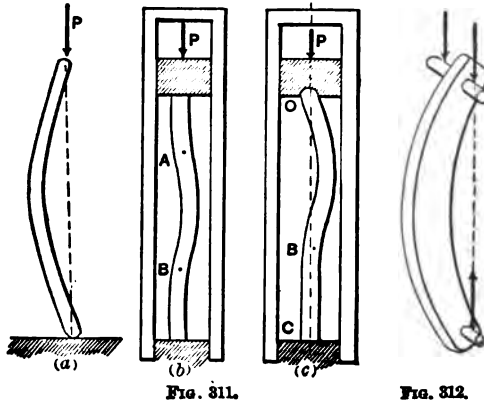

FIG. 311.

FIG. 312.

Sometimes a column is fixed at one end while the other end is not only round but *incapable of lateral deviation from the tangent line* of the other extremity; this state of end conditions is often spoken of as "Pin and Square," Fig. 311, (c).

If the rounding of the ends is produced by a hinge or "pin joint," Fig. 312, both pins lying in the same plane and having immovable bearings at their extremities, the column is to be considered as round-ended as regards flexure in the plane \perp to the pins, but as square-ended as regards flexure in the plane containing the axes of the pins.

The "moment of inertia" of the section of a column will be understood to be referred to a gravity axis of the section which is \perp to the plane of flexure (and this corresponds to the "force-plane" spoken of in previous chapters), or plane of the axis of column when bent.

303a. Euler's Formula.—Taking the case of a round-ended column, Fig. 313 (a), assume the middle of the length as an origin, with the axis X tangent to the elastic curve at that point. The flexure being slight, we may use the form $EI d^2y \div dx^2$ for the moment of the stress-couple in any

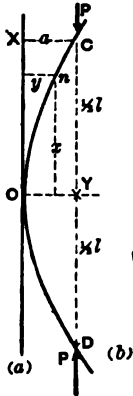

FIG. 313.

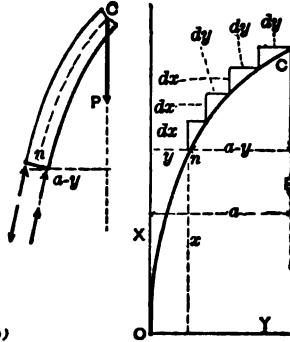

FIG. 314.

section n , remembering that with this notation the axis X must be \parallel to the beam, as in the figure (313). Considering the free body nC , Fig. 313 (b), we note that the shear is zero, that the uniform thrust $=P$, and that $\Sigma(\text{moms.}_n)=0$ gives (a being the deflection at O)

$$EI \frac{d^2y}{dx^2} = P(a-y) \quad . \quad . \quad . \quad (1)$$

Multiplying each side by dy we have

$$\frac{EI}{dx^3} dy d^2y = Pa dy - Py dy \quad . \quad . \quad . \quad (2)$$

Since this equation is true for the y , dx , dy , and d^2y of any element of arc of the elastic curve, we may suppose it written out for each element from O where $y=0$, and $dy=0$, up to any element, (where $dy=dy$ and $y=y$) (see Fig. 314) and then write the sum of the left hand members equal to that of the right hand members, remembering that, since dx is assumed constant, $1/dx^3$ is a common factor on the left. In other words, integrate between O and any point of the curve, n . That is,

$$\frac{EI}{dx^3} \int_{dy=0}^{dy} [dy] d[dy] = Pa \int_0^y dy - P \int_0^y y dy \quad (3)$$

The product $dy d^2y$ has been written $(dy)d(dy)$, (for d^2y is

the differential or increment of dy) and is of a form like $x dx$, or $y dy$. Performing the integration we have

$$\frac{EI}{dx^2} \cdot \frac{dy^2}{2} = Pay - P \frac{y^2}{2} \quad \dots \quad (4)$$

which is in a form applicable to any point of the curve, and contains the variables x and y and their increments dx and dy . In order to separate the variables, solve for dx , and we have

$$dx = \sqrt{\frac{EI}{P}} \frac{dy}{\sqrt{2ay - y^2}} \text{ or } dx = \sqrt{\frac{EI}{P}} \cdot \frac{d\left(\frac{y}{a}\right)}{\sqrt{2\frac{y}{a} - \left(\frac{y}{a}\right)^2}} \quad \dots \quad (5)$$

$$\therefore \int_0^a dx = \pm \sqrt{\frac{EI}{P}} \int_0^a \frac{d\left(\frac{y}{a}\right)}{\sqrt{2\frac{y}{a} - \left(\frac{y}{a}\right)^2}}$$

$$\text{i.e., } x = \pm \sqrt{\frac{EI}{P}} \left(\text{vers. sin}^{-1} \frac{y}{a}\right) \quad \dots \quad (6)$$

(6) is the equation of the elastic curve DOC , Fig. 313 (a), and contains the deflection a . If P and a are both given, y can be computed for a given x , and vice versâ, and thus the curve traced out, but we would naturally suppose a to depend on P , for in eq. (6) when $x = \frac{1}{2}l$, y should $= a$. Making these substitutions we obtain

$$\frac{1}{2}l = \sqrt{\frac{EI}{P}} \left(\text{vers. sin}^{-1} 1.00\right); \text{ i.e., } \frac{1}{2}l = \sqrt{\frac{EI}{P}} \frac{\pi}{2} \quad (7)$$

Since a has vanished from eq. (7) the value for P obtained from this equation, viz.:

$$P_0 = EI \frac{\pi^2}{l^2} \quad \dots \quad (8)$$

is independent of a , and is \therefore to be regarded as that force (at each end of the rounded column in Fig. 313) which will hold the column at any small deflection at which it may previously have been set.

In other words, if the force is less than P_0 no flexure at all will be produced, and hence P_0 is sometimes called the force producing "incipient flexure." [This is roughly verified by exerting a downward pressure with the hand on the upper end of the flexible rod (a T-square-blade for instance) placed vertically on the floor of a room; the pressure must reach a definite value before a decided buckling takes place, and then a very slight increase of pressure occasions a large increase of deflection.]

It is also evident that a force slightly greater than P_0 would very largely increase the deflection, thus gaining for itself so great a lever arm about the middle section as to cause rupture. For this reason eq. (8) may be looked upon as giving the **Breaking Load** of a column with round ends, and is called *Euler's formula*.

Referring now to Fig. 311, it will be seen that if the three parts into which the flat-ended column is divided by its two points of inflection A and B are considered free, individually, in Fig. 315, the forces acting will be as there shown, viz.: At the points of inflection there is no stress-couple, and no shear, but only a thrust, $=P$, and hence the portion AB is in the condition of a round-ended column. Also, the tangents to the elastic curves at O and C being preserved vertical by the frictionless guide-blocks and guides (which are introduced here simply as a theoretical method of preventing the ends from turning, but do not interfere with vertical freedom) OA is in the same state of flexure as half of AB and under the same forces. Hence the length AB must = one half the total length l of the flat-ended column. In other words, the breaking load of a round-ended column of length $=\frac{1}{2}l$, is the same as that of a flat-ended column of length $=l$. Hence for the l of eq. (8) write $\frac{1}{2}l$ and we have as the breaking load of a column with flat-ends and of length $=l$.

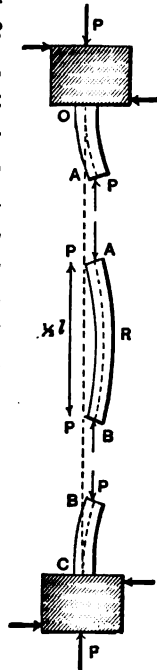

FIG. 315.

$$P_1 = 4 EI \frac{\pi^2}{l^2} \quad . \quad . \quad . \quad . \quad (9)$$

Similar reasoning, applied to the "pin-and-square" mode of support (in Fig. 311) where the points of inflection are at *B*, approximately $\frac{1}{3} l$ from *C*, and at the extremity *O* itself, calls for the substitution of $\frac{2}{3} l$ for *l* in eq. (8), and hence the breaking load of a "pin-and-square" column, of length = *l*, is

$$P_2 = \frac{9}{4} EI \frac{\pi^2}{l^2} \quad . \quad . \quad . \quad (10)$$

Comparing eqs. (8), (9), and (10), and calling the value of P_1 (flat-ends) unity, we derive the following statement :

The breaking loads of a given column are as the numbers

1	9/16	$\frac{1}{4}$	according to the
flat-ends	pin-and-square	round-ends	mode of support.

These ratios are approximately verified in practice.

Euler's Formula [i.e., eq. (8) and those derived from it, (9) and (10)] when considered as giving the breaking load is peculiar in this respect, that it contains no reference to the stress per unit of area necessary to rupture the material of the column, but merely assumes that the load producing "incipient flexure", i.e., which produces any bending at all, will eventually break the beam because of the greater and greater lever arm thus gained for itself. In the cantilever of Fig. 241 the bending of the beam does not sensibly affect the lever-arm of the load about the wall-section, but with a column, the lever-arm of the load about the mid-section is almost entirely due to the deflection produced.

304. Example. Euler's formula is only approximately verified by experiment. As an example of its use when considered as giving the force producing "incipient flexure" it will now be applied in the case of a steel T-square-blade whose ends are free to turn. Hence we use the round-end formula eq. (8) of §303, with the modulus of elasticity $E=30,000,000$ lbs. per sq. inch. The dimensions

are as follows: the length $l = 30$ in., thickness $= \frac{1}{30}$ of an inch, and width $= 2$ inches. The moment of inertia, I , about a gravity axis of the section \parallel to the width (the plane of bending being \parallel to the thickness) is (§247)

$$I = \frac{1}{12} b h^3 = \frac{1}{12} \times 2 \times \left(\frac{1}{30}\right)^3 = \frac{1}{162,000} \text{ biquad. inches.}$$

\therefore , with $\pi = 22 \div 7$,

$$P_0 = EI \frac{\pi^2}{l^2} = \frac{30,000,000}{162,000} \cdot \frac{22^2}{7^2} \cdot \frac{1}{900} = 2.03 \text{ lbs.}$$

Experiment showed that the force, a very small addition to which caused a large increase of deflection or side-buckling, was about 2 lbs.

305. Hodgkinson's Formulæ for Columns.—The principal practical use of Euler's formula was to furnish a general form of expression for breaking load, to Eaton Hodgkinson, who experimented in England in 1840 upon columns of iron and timber.

According to Euler's formula we have for cylindrical columns, I being $= \frac{1}{4} \pi r^4 = \frac{1}{64} \pi d^4$ (§247),

for flat-ends . . . $P_1 = \frac{1}{16} E \pi^3 \cdot \frac{d^4}{l^2}$

i.e., proportional to the fourth power of the diameter, and inversely as the square of the length. But Hodgkinson's experiments gave for wrought-iron cylinders

$$P_1 = (\text{const.}) \times \frac{d^{3.55}}{l^2}; \text{ and for cast iron } P_1 = (\text{const.}) \times \frac{d^{3.5}}{l^{1.7}}$$

Again, for a square column, whose side $= b$, Euler's formula would give

$$P_1 = \frac{1}{3} \pi^2 E \frac{b^4}{l^2}$$

while Hodgkinson found for square pillars of wood

$$P_1 = (\text{const.}) \times \frac{b^4}{l^2}$$

Hence in the case of wood these experiments indicated the same powers for b and l as Euler's formula, but with a different constant factor; while for cast and wrought iron the powers differ slightly from those of Euler.

Hodgkinson's formulæ are as follows, and evidently not homogeneous; the prescribed units should \therefore be carefully followed. d denotes the diameter of the cylindrical columns, b the side of square columns, l = length.

$$\left\{ \begin{array}{l} \text{For solid cylindrical cast iron columns, flat-ends;} \\ \text{Breaking load in tons} \\ \text{of 2,240 lbs. each} \end{array} \right\} = 44.16 \times (d \text{ in inches})^{3.65} \div (l \text{ in ft.})^{1.7}$$

$$\left\{ \begin{array}{l} \text{For solid cylindrical wrought iron columns, flat-ends;} \\ \text{Breaking load in tons} \\ \text{of 2,240 lbs. each} \end{array} \right\} = 134 \times (d \text{ in inches})^{3.65} \div (l \text{ in ft.})^2$$

$$\left\{ \begin{array}{l} \text{For solid square columns of dry oak, flat-ends;} \\ \text{Breaking load in tons} \\ \text{of 2,240 lbs. each} \end{array} \right\} = 10.95 \times (b \text{ in inches})^4 \div (l \text{ in ft.})^2$$

$$\left\{ \begin{array}{l} \text{For solid square columns of dry fir, flat-ends;} \\ \text{Breaking load in tons} \\ \text{of 2,240 lbs. each} \end{array} \right\} = 7.81 \times (b \text{ in inches})^4 \div (l \text{ in ft.})^2$$

Hodgkinson found that when the mode of support was "pin-and-square," the breaking load was about $\frac{1}{2}$ as great; and when the ends were rounded, about $\frac{1}{3}$ as great as with flat ends. These ratios differ somewhat from the theoretical ones mentioned in §303, just after eq. (10.)

Experiment shows that, strictly speaking, pin ends are not equivalent to round ends, but furnish additional strength; for the friction of the pins in their bearings hinders the turning of the ends somewhat. As the lengths become smaller the value of the breaking load in Hodgkinson's formulæ increases rapidly, until it becomes larger than would be obtained by using the formula for the crushing resistance of a short block (§201) viz., FC , i.e., the sectional area \times the crushing resistance per unit of area.

In such a case the pillar is called a short column, or "short block," and the value FC is to be taken as the breaking

load. This distinction is necessary in using Hodgkinson's formulæ; i.e., the breaking load is the smaller of the two values, FC and that obtained by Hodgkinson's rule.

In present practice Hodgkinson's formulæ are not often used except for hollow cylindrical iron columns, for which with d_2 and d_1 as the external and internal diameters, we have for flat-ends

$$\left. \begin{array}{l} \text{Breaking load in tons} \\ \text{of 2,240 lbs. each} \end{array} \right\} = \text{Const.} \times \frac{(d_2 \text{ in in.})^{2.55} - (d_1 \text{ in in.})^{2.55}}{(l \text{ in feet})^2}$$

in which the const. = 44.16 for cast iron, and 134 for wrought, while $n = 1.7$ for cast-iron and = 2 for wrought.

306. Examples of Hodgkinson's Formulæ.—Example 1. Required the breaking weight of a wrought-iron pipe used as a long column, having a length of 12 feet, an internal diameter of 3 in., and an external diameter of $3\frac{1}{4}$ inches, the ends having well fitted flat bases.

If we had regard simply to the sectional area of metal, which is $F = 1.22$ sq. inches, and treated the column as a short block (or short column) we should have for its compressive load at the elastic limit (see table §203) $P'' = FC'' = 1.22 \times 24,000 = 29,280$ lbs. and the safe load P^1 may be taken at 16,000 lbs.

But by the last formula of the preceding article we have

$$\left. \begin{array}{l} \text{Breaking load in} \\ \text{tons of 2,240 lbs. each} \end{array} \right\} = 134.0 \times \frac{(3.25)^{2.55} - 3^{2.55}}{12^2} = 15.07 \text{ tons}$$

i.e. = $15.07 \times 2240 = 33,768$ lbs.

Detail $[\log. 3.25] \times 3.55 = 0.511883 \times 3.55 = 1.817184$;

$$[\log. 3.00] \times 3.55 = 0.477,121 \times 3.55 = 1.693,779$$
 ;

and the corresponding numbers are 65.6 and 49.4; their difference = 16.2, hence

$$\begin{aligned} \text{Br. load in long tons} &= \frac{134 \times 16.2}{144} = 15.072 \text{ long tons.} \\ &= 33,768 \text{ lbs.} \end{aligned}$$

With a "factor of safety" (see §205) of four, we have, as the safe load, $P' = 8,442$ lbs. This being less than the 16000 lbs. obtained from the "short block" formula, should be adopted.

If the ends were rounded the safe load would be one-third of this i.e., would be 2,814 lbs; while with pin-and-square end-conditions, we should use one-half, or 4,221 lbs.

EXAMPLE 2. Required the necessary diameter to be given a solid cylindrical cast-iron pillar with flat ends, that its safe load may be 13,440 lbs. taking 6 as a factor of safety. Let d = the unknown diameter. Using the proper formula in § 305, and hence expressing the breaking load, which is to be six times the given safe load, in long tons we have (the length of column being 16 ft.)

$$\frac{13440 \times 6}{2240} = \frac{44.16 (d \text{ in inches})^{3.55}}{16^{1.7}} \dots (1)$$

$$\text{i.e. } [d \text{ in inches}]^{3.55} = \frac{36 \times 16^{1.7}}{44.16} \dots (2)$$

$$\begin{aligned} \text{or } \log.d &= \frac{1}{3.55} [\log. 36 + 1.7 \times \log. 16 - \log. 44.16] \dots (3) \\ \therefore \log.d &= \frac{1}{3.55} [1.958278] = 0.551627 \therefore d = 3.56 \text{ ins.} \end{aligned}$$

This result is for flat ends. If the ends were rounded, we should obtain $d = 4.85$ inches.

307. Rankine's Formula for Columns.—The formula of this name (some times called Gordon's, in some of its forms) has a somewhat more rational basis than Euler's, in that it introduces the maximum normal stress in the outer fibre and is applicable to a column or block of any length, but still contains assumptions not strictly borne out in theory, thus introducing some co-efficients requiring experimental determination. It may be developed as follows:

Since in the flat-ended column in Fig. 315 the middle portion AB , between the inflection points A and B , is acted on at each end by a thrust = P , not accompanied by any shear or stress-couple, it will be simpler to treat that

portion alone Fig. 316, (a), since the thrust and stress-couple induced in the section at *B*, the middle of *AB*, will be equal to those at the flat ends, *O* and *C*, in Fig. 315. Let *a* denote the deflection of *R* from the straight line *AB*. Now consider the portion *AR* as a free body in Fig. 316, (b), putting in the elastic forces of the section at *R*, which may be classified into a uniform thrust = $p_1 F$, and a stress couple of moment

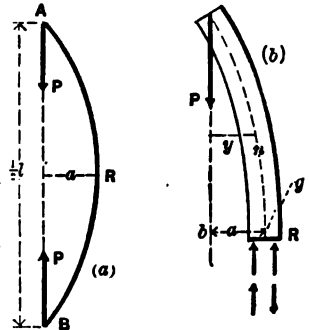

FIG. 316.

$= \frac{p_2 I}{e}$, (see § 294). (The shear is evidently zero, from

Σ (hor comps.) = 0). Here p_1 denotes the uniform pressure (per unit of area), due to the uniform thrust, and p_2 , the pressure or tension (per unit of area), in the elastic forces constituting the stress-couple, on the outermost element of area, at a distance *e* from the gravity axis (\perp to plane of flexure) of the section. *F* is the total area of the section. *I* is the moment of inertia about the said gravity axis, *g*

$$\Sigma \text{ (vert. comps.)} = 0 \text{ gives } P = p_1 F \quad . \quad . \quad (1)$$

$$\Sigma \text{ (moms.)} = 0 \text{ gives } Pa = \frac{p_2 I}{e} \quad . \quad . \quad . \quad (2)$$

For any section, *n*, between *A* and *R*, we would evidently have the same p_1 as at *R*, but a smaller p_2 , since $Py < Pa$ while *e*, *I*, and *F*, do not change, the column being prismatic. Hence the max. ($p_1 + p_2$) is on the concave edge at *R* and for safety should be no more than $C \div n$, where *C* is the Modulus of Crushing (§ 201) and *n* is a "factor of safety." Solving (1) and (2) for p_1 and p_2 , and putting their sum = $C \div n$, we have

$$\frac{P}{F} + \frac{Pae}{I} = \frac{C}{n} \quad . \quad . \quad . \quad (3)$$

We might now solve for *P* and call it the safe load, but it

is customary to present the formula in a form for giving the *breaking load*, the factor of safety being applied afterward. Hence we shall make $n = 1$, and solve for P , calling it then the breaking load. Now the deflection a is unknown, but may be expressed approximately, as follows, in terms of e and l .

Suppose two columns of lengths $= l'$ and l'' , each bearing its safe load. Then at the point R , $\frac{EI'}{\rho'} = \frac{P_1' l'}{e'}$; i.e., $E' e' = \rho' P_1'$. Considering the curve AB as a *circular arc* we have (see § 290) $a' = l'^2 + 32 \rho'$, i.e. $a' = \frac{P_1' l'^2}{32 E'}$; and similarly for the other column, $a'' = \frac{P_2'' l''^2}{32 E''}$. If the columns are of the same material $E' = E''$, and if each is bearing its safe load we may assume $P_1' = P_2''$ nearly, in which case the term $P_2'' \div E'' = P_1' \div E'$, and we may say that the deflection a , under safe load, is proportional to (length)² $\div e$, approximately, i. e., that $ae = \beta l^2$, where β is a constant (an abstract number also) dependent on experiment and different for different materials, and l the full length. We may also write, for convenience, $I = Fk^2$, k being the radius of gyration (see § 85). Hence, finally, we have from eq. (3)

$$\left. \begin{array}{l} \text{Breaking load} \\ \text{for flat ends} \end{array} \right\} = P_1 = \frac{FC}{1 + \beta \frac{l^2}{k^2}} \quad \dots \quad (4)$$

This is known as Rankine's formula.

By the same reasoning as in § 303, for a round-ended column we substitute $2l$ for l ; for a pin-and-square column $\frac{4}{3}l$ for l ; and \therefore obtain

$$\left. \begin{array}{l} \text{Breaking load} \\ \text{for a round-ended column} \end{array} \right\} = P_0 = \frac{FC}{1 + 4 \beta \frac{l^2}{k^2}} \quad \dots \quad (5)$$

$$\left. \begin{array}{l} \text{Breaking load for} \\ \text{a pin-and-square column} \end{array} \right\} = P_1 = \frac{FC}{1 + \frac{16}{9} \beta \frac{l^2}{k^2}} \quad \dots \quad (6)$$

These formulæ, (4), (5), and (6), unlike Hodgkinson's, are of *homogeneous form*. Any convenient system of units may therefore be used in them.

Rankine gives the following values for C and β , to be used in these formulæ. These are based on Hodgkinson's experiments.

	CAST IRON.	WR'T IRON.	TIMBER.
C in lbs. per sq. in.	80,000	36,000	7,200
β (abstract number)	$\frac{1}{6,400}$	$\frac{1}{36,000}$	$\frac{1}{3,000}$

If these numerical values of C are used F must be expressed in Sq. Inches and P in Pounds. Rankine recommends 4 as a factor of safety for iron in quiescent structures, 5 under moving loads; 10 for timber. The N. J. Iron & Steel Co. use Rankine's formula for their wrought iron rolled beams, when used as columns, with a factor of safety of $4\frac{1}{2}$.

308. Examples, Using Rankine's Formula.—EXAMPLE 1.—Take the same data for a wrought iron pipe used as a column, as in example 1, § 306; i.e., $l=12$ ft.=144 inches, $F=\frac{1}{4}[\pi(3\frac{1}{4})^2-\pi 3^2]=1.227$ sq. inches, while k^2 for a narrow circular ring like the present section may be put $=\frac{1}{2}(1\frac{5}{8})^2$ (see § 98) sq. inches. With these values, and $C=36,000$ lbs. per sq. in., and $\beta=\frac{1}{36,000}$ (for wrought iron), we have from eq. (4), for flat ends,

$$P_1 = \frac{1.227 \times 36,000}{1 + \frac{1}{36,000} \cdot \frac{1}{2} [1.625]^2} = 30743.6 \text{ lbs.} \quad (1)$$

This being the breaking load, the safe load may be taken $=\frac{1}{4}$ or $\frac{1}{5}$ of 30743.6 lbs., according as the structure of

which the column is a member is quiescent or subject to vibration from moving loads. By Hodgkinson's formula 33,768 lbs. was obtained as a breaking load in this case (§ 306).

For rounded ends we should obtain (eq. 5)

$$P_o = 16,100 \text{ lbs., as break. load} \quad . \quad . \quad (2)$$

and for pin-and-square, eq. (6)

$$P_s = 24,908 \text{ lbs. as break. load} \quad . \quad . \quad (3)$$

EXAMPLE 2.—(Same as Example 2, § 306). Required by Rankine's formula the necessary diameter, d , to be given a solid cylindrical cast-iron pillar, 16 ft. in length, with rounded ends, that its safe load may be six long tons (i.e., of 2,240 lbs. each) taking 6 as a factor of safety. $F = \frac{\pi d^3}{4}$, while the value of k^2 is thus obtained. From § 247, I for a full circle about its diameter $= \frac{1}{4} \pi r^4 = \pi r^2 \cdot \frac{1}{4} r^2 \therefore k^2 = \frac{1}{4} r^2 = \frac{1}{16} d^2$. Hence eq. (5) of § 307 becomes.

$$P_o = \frac{\frac{1}{4} \pi d^3 C}{1 + 4\beta \frac{16F}{d^2}} \quad . \quad . \quad (1)$$

P_o the breaking load is to be $= 6 \times 6 \times 2,240$ lbs., C for cast-iron is 80,000 lbs. per sq. inch, while β (abstract number) $= \frac{1}{6,400}$. Solving for d we have the biquadratic equation:

$$d^4 - \frac{28 \times 6 \times 6 \times 2,240}{22 \times 80,000} d^2 = \frac{28 \times 6 \times 6 \times 2,240 \times 16^2 \times 12^2 \times 4}{22 \times 80,000 \times 400}$$

whence $d^2 = 0.641 (1 \pm 33.92)$, and taking the upper sign, finally, $d = \sqrt{22.4} = 4.73$ inches. (By Hodgkinson's rule we obtained 4.85 inches).

309. Radii of Gyration.—The following table, taken from p. 523 of Rankine's Civil Engineering, gives values of k^2 , the square of the *least* radius of gyration of the given cross-section about a gravity-axis. By giving the *least* value of

It is implied that the plane of flexure is not determined by the end-conditions of the column; (i.e., it is implied that the column has either flat ends or round ends.) If either end (or both) is a *pin-joint* the column may need to be treated as having a flat-end as regards flexure in a plane containing the axis of the column and the axis of the pin, if the bearings of the pin are firm; while as regards flexure in a plane perpendicular to the pin it is to be considered round-ended at that extremity.

In the case of a "thin cell" the value of k^2 is strictly true for metal infinitely thin and of *uniform thickness*; still, if that thickness does not exceed $\frac{1}{8}$ of the exterior diameter, the form given is sufficiently near for practical purposes; similar statements apply to the branching forms.

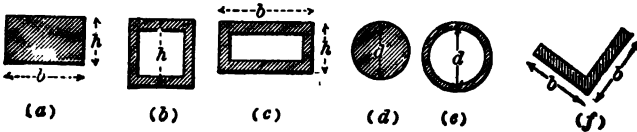

FIG. 317.

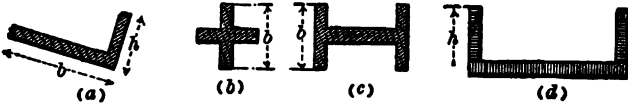

FIG. 318.

Solid Rectangle.

h = least side.

Fig. 317 (a). $k^2 = \frac{1}{12} h^2$

Thin Square Cell.

Side = h .

Fig. 317 (b). $k^2 = \frac{1}{6} h^2$

Thin Rectangular Cell.

h = least side.

Fig. 317 (c). $k^2 = \frac{h^2}{12} \cdot \frac{h+3b}{h+b}$

Solid Circular Section.

Diameter = d .

Fig. 317 (d). $k^2 = \frac{1}{16} d^2$

Thin Circular Cell.

Exterior diam. = d .

Fig. 317 (e). $k^2 = \frac{1}{8} d^2$

Angle-Iron of Equal ribs

Fig. 317 (f) $k^2 = \frac{1}{24} b^2$

- Angle-Iron of unequal ribs. Fig. 318 (a). $k^2 = \frac{b^2 h^2}{12(b^2 + k^2)}$
- Cross of equal arms. Fig. 318 (b). $k^2 = \frac{1}{24} b^2$
- I-Beam as a pillar.
Let area of web = B .
" " " both flanges = A .
Fig. 318 (c). $k^2 = \frac{b^2}{12} \cdot \frac{A}{A+B}$
- Channel Iron. Fig. 318 (d). $k^2 = k^2 \left[\frac{A}{12(A+B)} + \frac{AB}{4(A+B)^2} \right]$
- Let area of web = B ; of flanges = A (both). h extends from edge of flange to middle of web.

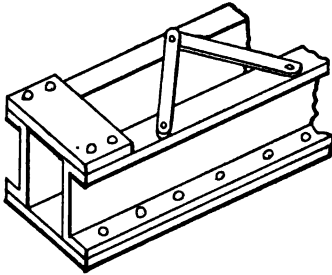
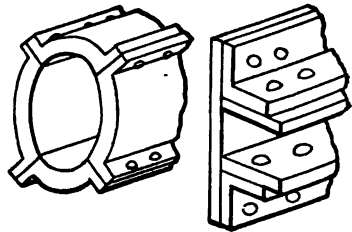

FIG. 319.



PHOENIX COLUMN.

FIG. 320.

310. Built Columns.—The "compression members" of wrought-iron bridge trusses are generally composed of several pieces riveted together, the most common forms being the Phoenix column (ring-shaped, in segments,) and combinations of channels, plates, and lattice, some of which are shown in Figs. 319 and 320.

Experiments on full size columns of these kinds were made by the U. S. Testing Board at the Watertown Arsenal about 1880.

The Phoenix columns ranged from 8 in. to 28 feet in length, and from 1 to 42 in the value of the ratio of length to diameter. The breaking loads were found to be somewhat in excess of the values computed from Rankine's formula; from 10 to 40 per cent. excess. In the pocket-book issued by the Phoenix company they give the following formula for their columns, (wrought-iron.)

$$\left. \begin{array}{l} \text{Breaking load in lbs.} \\ \text{for flat-ended columns} \end{array} \right\} = \frac{50,000 F}{1 + \frac{l^2}{3,000k^2}} \dots \dots \dots (1)$$

where F = area in sq. in., l = length, and k = external diameter, both in the same unit.

Many different formulae have been proposed by different engineers to satisfy these and other recent experiments on columns, but all are of the general form of Rankine's. For instance Mr. Bouscaren, of the Keystone Bridge Co., claims that the strength of Phoenix columns is best given by the formula

$$\left. \begin{array}{l} \text{Breaking load in} \\ \text{lbs. for flat-ends.} \end{array} \right\} = \frac{38,000 F}{1 + \frac{l^2}{100,000k^2}} \dots \dots \dots (2)$$

(F must be in square inches.)

The moments of inertia, I , and thence the value of $k^2 = I \div F$, for such sections as those given in Figs. 319 and 320 may be found by the rules of §§ 85-93, (see also § 258.)

311. Moment of Inertia of Built Column. Example.—It is proposed to form a column by joining two I-beams by lattice-work, Fig. 321, (a). (While the lattice-work is relied upon to cause the beams to act together as one piece, it is not regarded in estimating the area F , or the moment of inertia, of the cross section). It is also required to find the proper distance apart = x , Fig. 321, at which these beams must be placed, from centre to centre of webs, that the liability to flexure shall be equal in all axial planes, i.e. that the I of the compound section shall be the same about all gravity axes. This condition will be fulfilled if I_Y can be made = I_X * (§ 89), O being the centre of gravity of the compound section, and X perpendicular to the parallel webs of the two equal I-beams.

Let F' = the sectional area of one of the I-beams, P_Y (see Fig. 321(a) its moment of inertia about its web-axis, I_X' that about an axis Υ to web. (These quantities can be

* That is, with flat ends or ball ends; but with pin ends, Fig. 312, if the pin is \parallel to X , put $4I_Y = I_X$; if \parallel to Y , put $4I_X = I_Y$.

found in the hand-book of the iron company, for each size of rolled beam).

Then the

$$\text{total } I_x = 2I'_x; \text{ and total } I_y = 2\left[I'_y + F'\left(\frac{x}{2}\right)^2\right]$$

(see §88 eq. 4.) If these are to be equal, we write them so and solve for x , obtaining

$$x = \sqrt{\frac{4[I'_x - I'_y]}{F'}} \dots \dots \dots (1)$$

312. Numerically; suppose each girder to be a 10½ inch light I-beam, 105 lbs. per yard, of the N. J. Steel and Iron Co., in whose hand-book we find that for this beam $I'_x = 185.6$ biquad. inches, and $I'_y = 9.43$ biquad. inches, while $F' = 10.44$ sq. inches. With these values in eq. (1) we have

$$x = \sqrt{\frac{4(185.6 - 9.43)}{10.44}} = \sqrt{67.5} = 8.21 \text{ inches.}$$

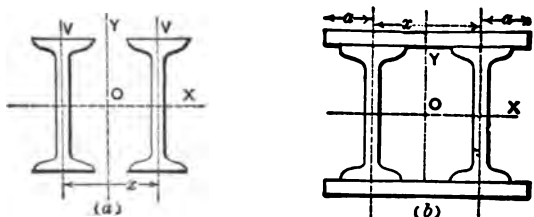

FIG. 321.

The square of the radius of gyration will be

$$k^2 = 2I'_x \div 2F' = 371.2 \div 20.88 = 17.7 \text{ sq. in.} \dots (2)$$

and is the same for any gravity axis (see § 89).

As an additional example, suppose the two I-beams united by plates instead of lattice. Let the thickness of the plate = t , Fig. 321, (b). Neglect the rivet-holes. The distance a is known from the hand-book. The student may derive a formula for x , imposing the condition that (total I_x) = I_y

313. Trussed Girders.—When a horizontal beam is trussed

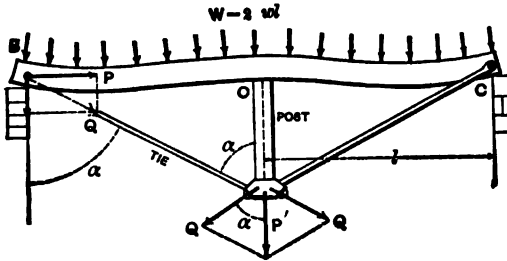

FIG. 322.

in the manner indicated in Fig. 322, with a single post or strut under the middle and two tie-rods, it is subjected to a longitudinal compression due to the tension of the tie-rods, and hence to a certain extent resists as a column, the plane of whose flexure is vertical, (since we shall here suppose the beam *supported laterally*.) Taking the case of uniform loading, (total load = W) and supposing the tie-rods screwed up (by sleeve nuts) until the top of the post is on a level with the piers, we know that the pressure between the post and the beam is $P' = \frac{5}{8} W$ (see § 273). Hence by the parallelogram of forces (see Fig. 322) the tension in each tie-rod is

$$Q = \frac{P'}{2 \cos \alpha} = \frac{5}{16} \cdot \frac{W}{\cos \alpha}$$

At each pier the horizontal component of Q is

$$P = Q \sin \alpha = \frac{5}{16} W \tan \alpha \quad (1)$$

Hence we are to consider the half-beam BO as a "pin-and-square" column under a compressive force $P = \frac{5}{16} W \tan \alpha$, as well as a portion of a continuous girder over three equidistant supports at the same level and bearing a uniform load W . In the outer fibre of the dangerous section, O , (see also § 273 and Fig. 278) the compression per sq. inch due to both these straining actions must not exceed a safe limit, R' , (see § 251). In eq. (6) § 307, where P_2 is the breaking force for a pin-and-square column, the great-

est stress in any outer fibre = C (— the Modulus of Crushing) per unit of area. If then we write p_{col} instead of C in that equation, and $\frac{5}{16} W \tan a$ instead of P , we have

$$\left\{ \begin{array}{l} \text{max. stress due} \\ \text{to column action} \end{array} \right\} = p_{\text{col}} = \frac{5}{16} \cdot \frac{W \tan a}{F} \left[1 + \frac{16}{9} \beta \cdot \frac{F}{k^2} \right];$$

while from eq. (3), p. 326, we have (remembering that our present W represents double the W of § 273).

$$\left\{ \begin{array}{l} \text{max. stress due} \\ \text{to girder action} \end{array} \right\} = p_{\text{st}} = \frac{1}{16} \frac{Wle}{I} = \frac{1}{16} \cdot \frac{Wle}{Fk^2}$$

By writing $p_{\text{col}} + p_{\text{st}} = R'$ — a safe value of compression per unit-area, we have the equation for safe loading

$$W \left[5 \tan a \left(1 + \frac{16}{9} \beta \frac{F}{k^2} \right) + \frac{le}{k^2} \right] = 16 FR' \quad \dots (2)$$

Here l = the half-span OB , Fig. 322, e = the distance of outer fibre from the horizontal gravity axis of the cross section, k^2 = the radius of gyration of the section referred to the same axis, while F = area of section. β should be taken from the end of § 307.

EXAMPLE. — If the span is 30 ft. = 360 in., the girder a 15 inch heavy I-beam of wrought iron, 200 lbs. to the yard, in which $e = \frac{1}{2}$ of 15 = 7½ inches, $F = 20$ sq. in., and $k^2 = 35.3$ sq. inches (taken from the Trenton Co.'s hand-book), required the safe load W , the strut being 5 ft. long. From § 307, $\beta = 1 : 36,000$; $\tan a = 15 \div 5 = 3.00$. Hence, using the units pound and inch throughout, and putting $R' = 12,000$ lbs. per sq. in. = max. allowable compression stress, we have from eq. (2)

$$W = \frac{16 \times 20 \times 12,000}{15 \left[1 + \frac{16}{9} \frac{1}{36,000} \cdot \frac{(180)^2}{35.3} \right] + \frac{180 \times 7\frac{1}{2}}{35.3}} = 71,111 \text{ lbs.} = 35.5 \text{ tons.}$$

i. e., 69,111 lbs. besides the weight of the beam.

If the middle support had been a solid pier, the safe load would have been 48 tons; while if there had been no middle support of any kind, the beam would bear safely

only 11.5 tons. [Let the student design the tie-rods (and the strut)].

314. Buckling of Web-Plates in Built Girders.—In §257 mention was made of the fact that very high web plates in built beams, such as *I* beams and box-girders, might need to be stiffened by riveting T-irons on the sides of the web. (The girders here spoken of are horizontal ones, such as might be used for carrying a railroad over a short span of 20 to 30 feet.

An approximate method of determining whether such stiffening is needed to prevent lateral buckling of the web, may be based upon Rankine's formula for a long column and will now be given.

In Fig. 323 we have, free, a portion of a bent *I*-beam, between two vertical sections at a distance apart— $h_1 =$ the height of the web. In such a beam under forces \perp to its axis it has been proved (§256) that we may consider the web to sustain all the shear, J , at any section, and the flanges to take all the tension and compression, which form the "stress-couple" of the section. These couples and the two shears are shown in Fig. 323, for the two exposed sections. There is supposed to be no load on this portion of the beam, hence the shears at the two ends are

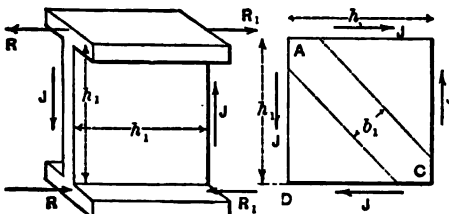

FIG. 323.

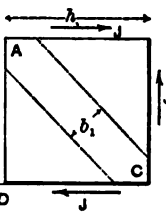

FIG. 324.

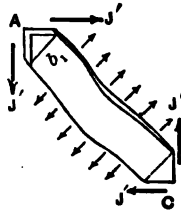

FIG. 325.

equal. Now the shear acting between each flange and the horizontal edge of the web is equal in intensity per square inch to that in the vertical edge of the web; hence if the web alone, of Fig. 323, is shown as a free body in Fig. 324, we must insert two horizontal forces = J , in opposite

directions, on its upper and lower edges. Each of these = J since we have taken a horizontal length h_1 = height of web. In this figure, 324, we notice that the effect of the acting forces is to lengthen the diagonal BD and shorten the diagonal AC , both of those diagonals making an angle of 45° with the horizontal.

Let us now consider this buckling tendency along AC , by treating as free the strip AC , of small width = b_r . This is shown in Fig. 325. The only forces acting in the direction of its length AC are the components along AC of the four forces J' at the extremities. We may therefore treat the strip as a long column of a length $l = h_1 \sqrt{2}$, of a sectional area $F = bb_1$, (where b is the thickness of the web plate), with a value of $k^2 = \frac{1}{12} b^2$ (see § 309), and with fixed (or flat) ends. Now the sum of the longitudinal components of the two J' 's at A is $Q = 2 J' \frac{1}{2} \sqrt{2} = J' \sqrt{2}$; but J' itself = $\frac{J}{bh_1} \cdot b \frac{1}{2} h_1 \sqrt{2}$, since the small rectangle on which J' acts has an area = $b \frac{1}{2} h_1 \sqrt{2}$, and the shearing stress on it has an intensity of $(J \div bh_1)$ per unit of area. Hence the longitudinal force at each end of this long column is

$$Q = \frac{b_1 J}{h_1} \dots \dots \dots (1)$$

According to eq. (4) and the table in § 307, the *safe load* (factor of safety = 4) for a *wrought-iron* column of this form, with flat ends, would be (pound and inch)

$$P_1 = \frac{\frac{1}{4} bb_1 36,000}{1 + \frac{1}{36,000 \frac{1}{12} b^2}} = \frac{9,000 bb_1}{1 + \frac{1}{1,500} \frac{h_1^2}{b^2}} \dots \dots (2)$$

If, then, in any particular locality of the girder (of *wrought-iron*) we find that Q is $> P_1$, i.e.

$$\text{if } \frac{J}{h_1} \text{ is } > \frac{9,000b}{1 + \frac{1}{1,500} \frac{h_1^2}{b^2}} \text{ (pound and inch) } \dots (3)$$

then vertical stiffeners will be required laterally.

When these are required, they are generally placed at intervals equal to h_1 , (the depth of web), along that part of the girder where Q is $> P_1$.

EXAMPLE Fig. 326.—Will stiffening pieces be required in a built girder of 20 feet span, bearing a uniform load of 40 tons, and having a web 24 in. deep and $\frac{3}{8}$ in. thick?

From § 242 we know that the greatest shear, J max., is close to either pier, and hence we investigate that part of the girder first.

$$J \text{ max.} = \frac{1}{2} W = 20 \text{ tons} = 40,000 \text{ lbs.}$$

\therefore (inch and lb.), see (3),

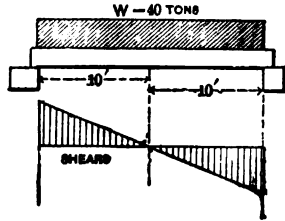

FIG. 326.

$$\frac{J}{h_1} = \frac{40,000}{24} = 1666.6 \dots \dots \dots (4)$$

while, see (3), (inch and pound),

$$\frac{9,000 \times \frac{3}{8}}{1 + \frac{1}{1,500} \cdot \frac{24^2}{(\frac{3}{8})^2}} = 905.0 \dots \dots \dots (5)$$

which is less than 1666.66.

Hence stiffening pieces will be needed near the extremities of the girder. Also, since the shear for this case of loading diminishes uniformly toward zero at the middle they will be needed from each end up to a distance of $\frac{905}{1666}$ of 10 ft. from the middle.

CHAPTER VII.

LINEAR ARCHES (OF BLOCKWORK).

315. A **Blockwork Arch** is a structure, spanning an opening or gap, depending, for stability, upon the resistance to *compression* of its blocks, or *voussoirs*, the material of which, such as stone or brick, is not suitable for sustaining a tensile strain. Above the voussoirs is usually placed a load of some character, (e.g. a roadway,) whose pressure upon the voussoirs will be *considered as vertical*, only. This condition is not fully realized in practice, unless the load is of cut stone, with vertical and horizontal joints resting upon voussoirs of corresponding shape (see

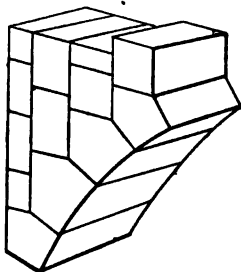

FIG. 327.

Fig. 327), but sufficiently so to warrant its assumption in theory. Symmetry of form about a vertical axis will also be assumed in the following treatment.

316. **Linear Arches.**—For purposes of theoretical discussion the voussoirs of Fig. 327 may be considered to become infinitely small and infinite in number, thus forming a “linear arch,” while retaining the same shapes, their depth γ to the face being assumed constant that it may not appear in the formulæ. The joints between them are γ to the curve of the arch, i.e., adjacent voussoirs can exert pressure on each other only in the direction of the tangent-line to that curve.

317. Inverted Catenary, or Linear Arch Sustaining its Own Weight Alone.—Suppose the infinitely small voussoirs to have weight, uniformly distributed along the curve, weighing q lbs. per running linear unit. The equilibrium of such a structure, Fig. 328, is of course unstable but theoretically possible. Required the form of the curve when equilibrium exists. The conditions of equilibrium are, obviously: 1st. The thrust or mutual pressure T between any two adjacent voussoirs at any point, A , of the curve must be tangent to the curve; and 2ndly, considering a portion BA as a free body, the resultant of H_0 the pres-

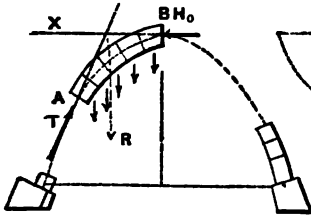

FIG. 328.

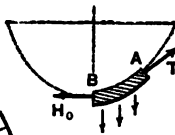

FIG. 329.

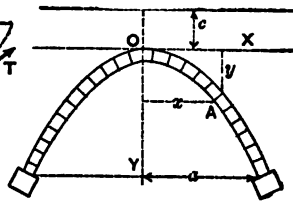

FIG. 330.

sure at B the crown, and T at A , must balance R the resultant of the \parallel vertical forces (i.e., weights of the elementary voussoirs) acting between B and A .

But the conditions of equilibrium of a flexible, inextensible and uniformly loaded cord or chain are the very same (weights uniform along the curve) the forces being reversed in direction. Fig. 329. Instead of compression we have tension, while the \parallel vertical forces act toward instead of away from, the axis X . Hence the curve of equilibrium of Fig. 328 is an inverted catenary (see § 48) whose equation is

$$y \pm c = \frac{1}{2}c \left[e^{\frac{x}{c}} + e^{-\frac{x}{c}} \right] \dots \dots \dots (1)$$

See Fig. 330. $e = 2.71828$ the Naperian Base. The "parameter" c may be determined by putting $x = a$, the half span, and $y = OY$, the rise, then solving for c by successive

approximations. The "horizontal thrust," or H_0 , is $= qc$, while if s = length of arch OA , along the curve, the thrust T at any point A is

$$T = \sqrt{H_0^2 + q^2 s^2} \dots \dots \dots (2)$$

From the foregoing it may be inferred that a series of voussoirs of *finite dimensions*, arranged so as to contain the catenary curve, with joints \perp to that curve and of equal weights for equal lengths of arc will be in equilibrium, and moreover in *stable* equilibrium on account of friction, and the finite width of the joints; see Fig. 331.

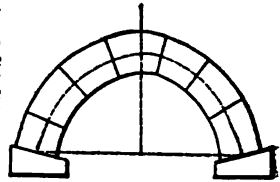

FIG. 331.

318. Linear Arches under Given Loading.—The linear arches to be considered further will be treated as without weight themselves but as bearing vertically pressing loads (each voussoir its own).

Problem.—Given the form of the linear arch itself, it is required to find the law of vertical depth of loading under which the given linear arch will be in equilibrium. Fig. 332, given the curve ABC , i.e., the linear arch itself, required the form of the curve MON , or upper limit of loading, such that the linear arch ABC shall be in equilibrium under the loads lying between the two curves. The loading is supposed homogeneous and of constant depth γ to paper; so that the ordinates z between the two curves are proportional to the *load per horizontal linear unit*. Assume a height of load z_0 at the crown, at pleasure; then required the z of any point m as a function of z_0 and the curve ABC .

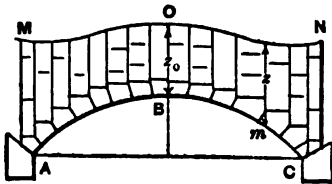

FIG. 332.

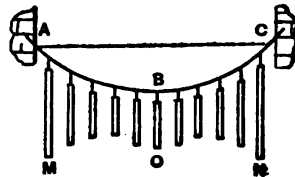

FIG. 333.

Practical Solution.—Since a linear arch under vertical pressures is nothing more than the inversion of the curve assumed by a cord loaded in the same way, this problem might be solved mechanically by experimenting with a light cord, Fig. 333, to which are hung other heavy cords, or bars of uniform weight per unit length, and at equal horizontal distances apart when in equilibrium. By varying the lengths of the bars, and their points of attachment, we may finally find the curve sought, *MON*. (See also § 343.)

Analytical Solution.—Consider the structure in Fig. 334. A number of rods of finite length, in the same plane, are in equilibrium, bearing the weights *P, P₁*, etc., at the con-

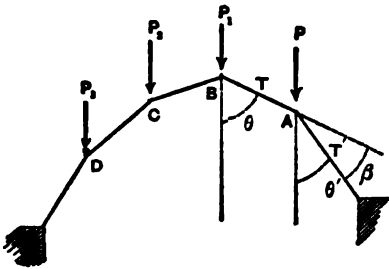

FIG. 334.

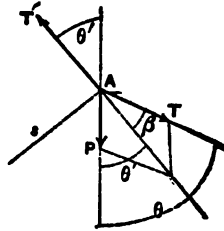

FIG. 335.

necting joints, each piece exerting a thrust *T* against the adjacent joint. The joint *A*, (the “pin” of the hinge), imagined separated from the contiguous rods and hence free, is held in equilibrium by the vertical force *P* (a load) and the two thrusts *T* and *T'*, making angles = θ and θ' with the vertical; Fig. 335 shows the joint *A* free. From $\Sigma(\text{horizontal comps.})=0$, we have

$$T \sin \theta = T' \sin \theta'.$$

That is, the horizontal component of the thrust in any rod is the same for all; call it *H*. ∴

$$T = \frac{H}{\sin \theta} \tag{1}$$

Now draw a line $As \perp$ to T' and write Σ (compons. \perp to As)=0; whence $P \sin \theta' = T \sin \beta$, and [see (1)]

$$\therefore P = \frac{H_0 \sin \beta}{\sin \theta \sin \theta'} \tag{2}$$

Let the rods of Fig. 334 become infinitely small and infinite in number and the load continuous. The length of each rod becomes $=ds$ an element of the linear arch. β is the angle between two consecutive ds 's, θ is the angle between the tangent line and the vertical, while P becomes the load resting on a single dx , or horizontal distance between the middles of the two ds 's. That is, Fig. 336, if γ = weight of a cubic unit of the loading, $P = \gamma dx$. (The lamina of arch and load considered is unity, \perp to paper, in thickness.) H_0 = a constant = thrust at crown O ; $\theta = \theta'$, and $\sin \beta = ds \div \rho$, (since the angle between two consecutive tangents is = that between two consecutive radii of curvature). Hence eq. (2) becomes

$$\gamma dx = \frac{H_0 ds}{\rho \sin^2 \theta}; \text{ but } dx = ds \sin \theta,$$

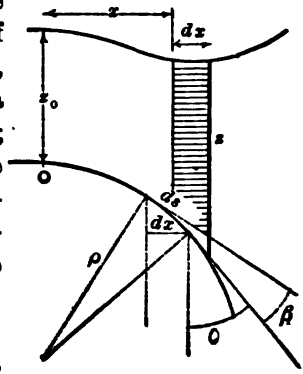

FIG. 336.

$$\therefore \gamma z = \frac{H_0}{\rho \sin^3 \theta} \tag{3}$$

Call the radius of curvature at the crown ρ_0 , and since there $z = z_0$ and $\theta = 90^\circ$, (3) gives $\gamma z_0 \rho_0 = H_0$; hence (3) may be written

$$z = \frac{z_0 \rho_0}{\rho \sin^3 \theta} \tag{4}$$

This is the law of vertical depth of loading required. For a point of the linear arch where the tangent line is vertical, $\sin \theta = 0$ and z would = ∞ ; i.e., the load would be in-

finitely high. Hence, in practice, a full semi-circle, for instance, could not be used as a linear arch.

319. Circular Arc as Linear Arch.—As an example of the

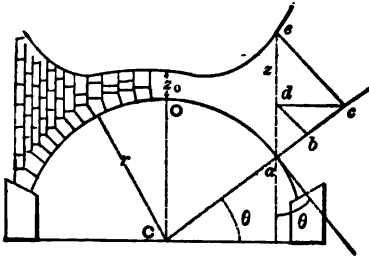

FIG. 337.

preceding problem let us apply eq. (4) to a circular arc, Fig. 337, as a linear arch. Since for a circle ρ is constant $=r$, eq. (4) reduces to

$$z = \frac{z_0}{\sin^3 \theta} \quad (5)$$

Hence the depth of loading must vary inversely as the cube of the sine of the angle θ made by the tangent line (of the linear arch) with the vertical.

To find the depth z by construction.—Having z_0 given, O being the centre of the arch, prolong Ca and make $ab = z_0$; at b draw a \perp to Ob , intersecting the vertical through a at some point d ; draw the horizontal dc to meet Ca at some point c . Again, draw $ce \perp$ to Cc , meeting ad in e ; then $ae = z$ required; a being any point of the linear arch. For, from the similar right triangles involved, we have

$$z_0 = \overline{ab} = \overline{ad} \sin \theta = \overline{ac} \sin \theta. \sin \theta = \overline{ae} \sin \theta \sin \theta \sin \theta$$

$$\therefore \overline{ae} = \frac{z_0}{\sin^3 \theta}; \text{ i.e., } \overline{ae} = z. \quad \text{Q.E.D.}$$

[see (5).]

320. Parabola as Linear Arch.—To apply eq. 4 § 318 to a parabola (axis vertical) as linear arch, we must find values of ρ and ρ_0 the radii of curvature at any point and the crown respectively. That is, in the general formula,

$$\rho = \left[1 + \left(\frac{dy}{dx} \right)^2 \right]^{\frac{3}{2}} \div \frac{d^2y}{dx^2}$$

we must substitute the forms for the first and second differential co-efficients, derived from the equation of the

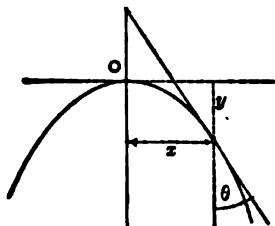

FIG. 338.

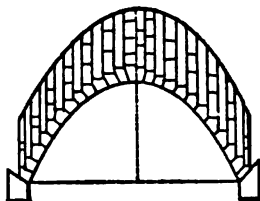

FIG. 339.

curve (parabola) in Fig. 338, i.e. from $x^2 = 2py$; whence we obtain

$$\frac{dy}{dx}, \text{ or } \cot \theta, = \frac{x}{p} \text{ and } \frac{d^2y}{dx^2} = \frac{1}{p}$$

$$\text{Hence } \rho = \frac{(\sqrt{1 + \cot^2 \theta})^3}{1 + p} = p \operatorname{cosec}^3 \theta, \text{ i.e. } \rho = \frac{p}{\sin^3 \theta} \quad \dots (6)$$

At the vertex $\theta = 90^\circ \therefore \rho_0 = p$. Hence by substituting for ρ and ρ_0 in eq. (4) of § 318 we obtain

$$z = z_0 = \text{constant [Fig. 339]} \quad \dots (7)$$

for a parabolic linear arch. Therefore the depth of homogeneous loading must be the same at all points as at the crown; i.e., the load is uniformly distributed with respect to the horizontal. This result might have been anticipated from the fact that a cord assumes the parabolic form when its load (as approximately true for suspension bridges) is uniformly distributed horizontally. See § 46 in Statics and Dynamics.

321. Linear Arch for a Given Upper Contour of Loading, the arch itself being the unknown lower contour. Given the upper curve or limit of load and the depth z_0 at crown, required the form of linear arch which will be in equilibrium under the homogenous load between itself and that upper curve. In Fig. 340 let MON be the given upper contour of load, z_0 is given or assumed, z' and z'' are the respective ordinates of the two curves BAC and MON . Required the equation of BAC .

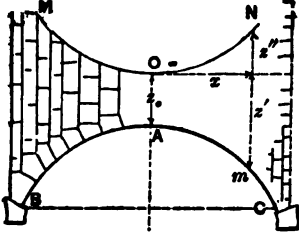

FIG. 340.

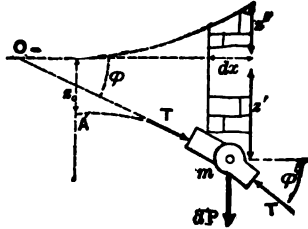

FIG 341.

As before, the loading is homogenous, so that the weights of any portions of it are proportional to the corresponding areas between the curves. (Unity thickness \uparrow to paper.) Now, Fig. 341, regard two consecutive dx 's of the linear arch as two links or consecutive blocks bearing at their junction m the load $dP = \gamma (z' + z'') dx$ in which γ denotes the heaviness of weight of a cubic unit of the loading. If T and T' are the thrusts exerted on these two blocks by their neighbors (here supposed removed) we have the three forces dP , T and T' , forming a system in equilibrium. Hence from $\Sigma X = 0$,

$$T \cos \varphi = T' \cos \varphi' \dots \dots \dots (1)$$

and

$$\Sigma Y = 0 \text{ gives } T \sin \varphi' - T \sin \varphi = dP \dots \dots (2)$$

From (1) it appears that $T \cos \varphi$ is constant at all points of the linear arch (just as we found in § 318) and hence — the thrust at the crown, = H , whence we may write

$$T = H \div \cos \varphi \text{ and } T' = H \div \cos \varphi' \dots \dots (3)$$

Substituting from (3) in (2) we obtain

$$H (\tan \varphi' - \tan \varphi) = dP \dots \dots \dots (4)$$

But $\tan \varphi' = \frac{dz'}{dx}$ and $\tan \varphi = \frac{dz' + d^2z'}{dx}$, (dx constant)

while $dP = \gamma (z' + z'') dx$. Hence, putting for convenience $H = \gamma a^2$, (where a = side of an imaginary square of the

loading, whose thickness = unity and whose weight = H) we have.

$$\frac{d^2z'}{dx^2} = \frac{1}{a^2}(z' + z'') \dots \dots \dots (5)$$

as a relation holding good for any point of the linear arch which is to be in equilibrium under the load included between itself and the given curve whose ordinates are z' , Fig. 340.

322. Example of Preceding. Upper Contour a Straight Line.— Fig. 342. Let the upper contour be a right line and horizontal; then the z'' of eq. 5 becomes zero at all points of ON . Hence drop the accent of z' in eq. (5) and we have

$$\frac{d^2z}{dx^2} = \frac{z}{a^2}$$

Multiplying which by dx we obtain

$$\frac{dz}{dx} \frac{d^2z}{dx^2} = \frac{1}{a^2} z dx \dots \dots \dots (6)$$

This being true of the z , dz , d^2z and dx of each element of the curve $O'B$ whose equation is desired, conceive it written out for each element between O' and any point m , and put the sum of the left-hand members of these equations = to that of the right-hand members, remembering that a^2 and dx^2 are the same for each element. This gives

$$\begin{aligned} \frac{1}{dx^2} \int_{z_0}^{z-z} dz d^2z &= \frac{1}{a^2} \int_{z_0}^{z-z} z dx; \text{ i.e., } \frac{1}{dx^2} \frac{dz^2}{2} = \frac{1}{a^2} \left[\frac{z^2}{2} - \frac{z_0^2}{2} \right] \\ \therefore dx &= \frac{adz}{\sqrt{z^2 - z_0^2}} = a \cdot \frac{d\left(\frac{z}{z_0}\right)}{\sqrt{\left(\frac{z}{z_0}\right)^2 - 1}} \dots \dots \dots (7) \end{aligned}$$

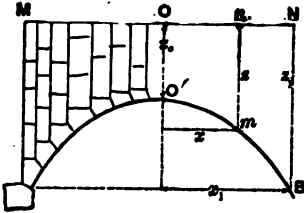

FIG. 342.

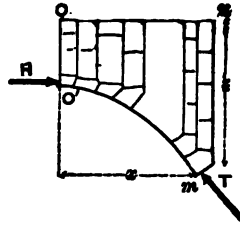

FIG. 343.

Integrating (7.) between O' and any point m

$$\left[x \right]_0^z = a \left[\log_e \left(\frac{z}{z_0} + \sqrt{\left(\frac{z}{z_0} \right)^2 - 1} \right) \right] \dots (8')$$

i.e., $x = a \log_e \left[\frac{z}{z_0} + \sqrt{\left(\frac{z}{z_0} \right)^2 - 1} \right]; \dots (8.)$

or $z = \frac{z_0}{2} \left[e^{\frac{x}{a}} + e^{-\frac{x}{a}} \right] \dots (9.)$

This curve is called the **transformed catenary** since we may obtain it from a common catenary by altering all the ordinates of the latter in a constant ratio, just as an ellipse may be obtained from a circle. If in eq. (9) a were $= z_0$, the curve would be a common catenary.

Supposing z_1 and the co-ordinates x_1 and z_1 of the point B (abutment) given, we may compute a from eq. 8 by putting $x = x_1$ and $z = z_1$, and solving for a . Then the crown-thrust $H = \gamma a^2$ becomes known, and a can be used in eqs. (8) or (9) to plot points in the curve or linear arch. From eq. (9) we have

$$\left. \begin{array}{l} \text{area} \\ OO'mn \end{array} \right\} = \int_0^x \gamma dx = \frac{\gamma}{2} \int_0^x \left[e^{\frac{x}{a}} dx + e^{-\frac{x}{a}} dx \right] = \frac{\gamma a^2}{2} \left[e^{\frac{x}{a}} - e^{-\frac{x}{a}} \right] \dots (10)$$

Fig. 343.

Call this area, A . As for the thrusts at the different joints of the linear arch, see Fig. 343, we have crown-thrust $= H = \gamma a^2 \dots (11)$ and at any joint m the thrust

$$T = \sqrt{H^2 + (\gamma A)^2} = \gamma \sqrt{a^4 + A^2} \dots (12)$$

323. Remarka.—The foregoing results may be utilized with arches of finite dimensions by making the arch-ring contain the imaginary linear arch, and the joints Γ to the curve of the same. Questions of friction and the resistance of the material of the voussoirs are reserved for a succeeding chapter, (§ 344) in which will be advanced a more practical theory dealing with approximate linear arches or “equilibrium polygons” as they will then be called. Still, a study of exact linear arches is valuable on many accounts. By inverting the linear arches so far presented we have the forms assumed by flexible and inextensible cords loaded in the same way.

CHAPTER VIII.

ELEMENTS OF GRAPHICAL STATICS.

324. Definition.—In many respects graphical processes have advantages over the purely analytical, which recommend their use in many problems where celerity is desired without refined accuracy. One of these advantages is that gross errors are more easily detected, and another that the relations of the forces, distances, etc., are made so apparent to the eye, in the drawing, that the general effect of a given change in the data can readily be predicted at a glance.

Graphical Statics is the system of geometrical constructions by which problems in Statics may be solved by the use of drafting instruments, forces as well as distances being represented in amount and direction by lines on the paper, of proper length and position, according to arbitrary scales; so many feet of distance to the linear inch of paper, for example, for distances; and so many pounds or tons to the linear inch of paper for forces.

Of course results should be interpreted by the same scale as that used for the data. The parallelogram of forces is the basis of all constructions for combining and resolving forces.

325. Force Polygons and Concurrent Forces in a Plane.—If a material point is in equilibrium under three forces P_1 , P_2 , P_3 (in the same plane of course) Fig. 344, any one of them,

as P_1 , must be equal and opposite to R the resultant of the other two (diagonal of their parallelogram). If now we lay off to some convenient scale a line in Fig. 345 = P_1 and \parallel to P_1 in Fig. 344 ; and then from the *pointed* end

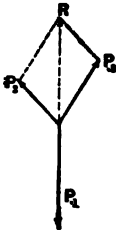

FIG. 344.



FIG. 345.

of P_1 a line equal and \parallel to P_2 , and laid off *pointing the same way*, we note that the line remaining to close the triangle in Fig. 345 must be = and \parallel to P_3 , since that triangle is nothing more than the left-hand half-parallelogram of Fig. 344. Also, in 345, to close the triangle properly the directions of the arrows must be continuous *Point to Butt*, round the periphery. Fig. 345 is called a *force polygor*; of three sides only in this case. By means of it, given any two of the three forces which hold the point in equilibrium, the third can be found, being equal and \parallel to the side necessary to "close" the force polygon.

Similarly, if a number of forces in a plane hold a material point in equilibrium, Fig. 346, their force polygon,

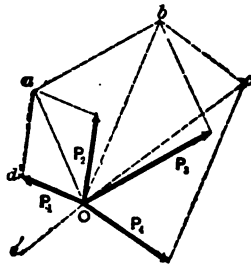

FIG. 346.

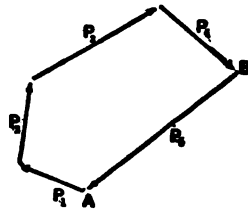

FIG. 347.

Fig. 347, must close, whatever be the order in which its sides are drawn. For, if we combine P_1 and P_2 into a resultant Oa , Fig. 346, then this resultant with P_3 to form a resultant Ob , and so on ; we find the resultant of P_1, P_2, P_3 , and P_4 to be Oc , and if a fifth force is to produce equilibrium it must be equal and opposite to Oc , and would close the polygon $OdabcO$, in which the sides are equal and par-

allel respectively to the forces mentioned. To utilize this fact we can dispense with all parts of the parallelograms in Fig. 346 except the sides mentioned, and then proceed as follows in Fig. 347 :

If P_5 is the unknown force which is to balance the other four (i.e. is their *anti-resultant*), we draw the sides of the force polygon from A round to B , making each line parallel and equal to the proper force and pointing the same way ; then the line BA represents the required P_5 in amount and direction, since the arrow BA must follow the continuity of the others (point to butt).

If the arrow BA were pointed at the extremity B , then it gives, obviously, the amount and direction of the *resultant* of the four forces $P_1 \dots P_4$. The foregoing shows that if a system of **Concurrent Forces in a Plane** is in equilibrium, its *force polygon must close*.

326. Non-Concurrent Forces in a Plane.—Given a system of non-concurrent forces in a plane, acting on a rigid body, required graphic means of finding their resultant and anti-resultant ; also of expressing conditions of equilibrium. The resultant must be found in *amount and direction* ; and also in *position* (i.e., its *line of action* must be determined). E. g., Fig. 348 shows a curved rigid beam fixed in a vise at T , and also under the action of forces $P_1 P_2 P_3$ and P_4 (*besides* the action of the vise) ; required the resultant of

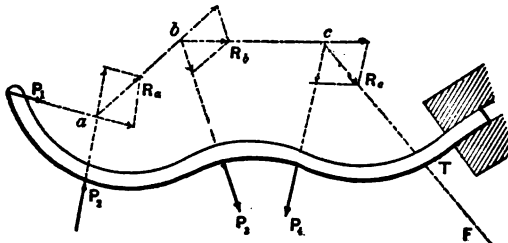

FIG. 348.

$P_1, P_2, P_3,$ and P_4 . By the ordinary parallelogram of forces we combine P_1 and P_2 at a , the intersection of their lines of action, into a resultant R_1 ; then R_1 with P_3 at b , to form R_2 ; and finally R_2 with P_4 at c to form R_3 which is \therefore the resultant required, i.e., of $P_1 \dots P_4$; and $c \dots F$ is its line of action.

The separate force triangles (half-parallelograms) by which the successive partial resultants R_n , etc., were found, are again drawn in Fig. 349.

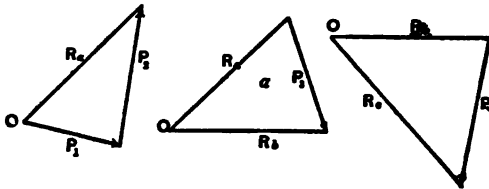
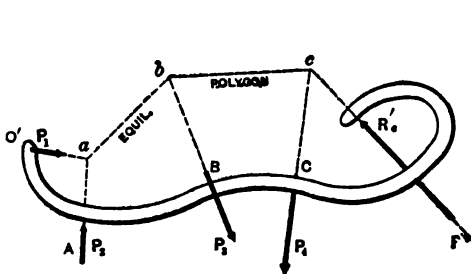

FIG. 349.

Now since R_n , acting in the line $c \dots F$, Fig. 348, is the resultant of $P_1 \dots P_n$, it is plain that a force R_c' equal to R_n and acting along $c \dots F$, but in the opposite direction, would balance the system $P_1 \dots P_n$, (is their anti-resultant).

That is, the forces P_1, P_2, P_3, P_4 and R_c' would form a system in equilibrium. The force R_c' then, represents the action of the vise T upon the beam. Hence replace the vise by the force R_c' acting in the line $\dots F \dots c$; to do which requires us to imagine a rigid prolongation of that end of the beam, to intersect $F \dots c$. This is shown in Fig. 350 where the whole beam is *free*, in equilibrium, under the forces shown, and in precisely the same state of stress, part for part, as in Fig. 348. Also, by combining in one force diagram, in Fig. 351, all the force triangles of Fig. 349 (by making their common sides coincide, and putting R_c' instead of R_n , and dotting all forces other than those of Fig. 350), we have a figure to be interpreted in connection with Fig. 350.



SPACE DIAGRAM

FIG. 350.

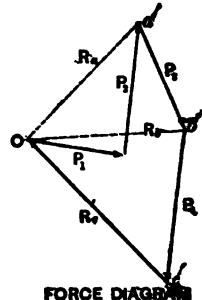

FORCE DIAGRAM

FIG. 351.

Here we note, first, that in the figure called a force-diagram, P_1, P_2, P_3, P_4 and R_c' form a closed polygon and that

their arrows follow a continuous order, point to butt, around the perimeter ; which proves that one condition of equilibrium of a system of non-concurrent forces in a plane is that its force polygon must close. Secondly, note that ab is \parallel to Oa' , and bc to Ob' ; hence if the force-diagram has been drawn (including the rays, dotted) in order to determine the amount and direction of R_c' , or any other one force, we may then find its line of action in the space-diagram, as follows: (N. B.—By space diagram is meant the figure showing to a true scale the form of the rigid body and the lines of action of the forces concerned). Through a , the intersection of P_1 and P_2 , draw a line \parallel to Oa' to cut P_3 in some point b ; then through b a line \parallel to Ob' to cut P_4 at some point c ; cF drawn \parallel to Oc' is the required line of action of R_c' , the anti-resultant of P_1, P_2, P_3 , and P_4 .

abc is called an equilibrium polygon; this one having but two segments, ab and bc (sometimes the lines of action of P_1 and R_c' may conveniently be considered as segments.) *The segments of the equilibrium polygon are parallel to the respective rays of the force diagram.*

Hence for the equilibrium of a system of non-concurrent forces in a plane *not only must its force polygon close, but also the first and last segments of the corresponding equilibrium polygon must coincide with the resultants of the first two forces, and of the last two forces, respectively, of the system.* *E.g., ab coincides with the line of action of the resultant of P_1 and P_2 ; bc with that of P_3 and R_c' .* Evidently the equil. polygon will be different with each different order of forces in the force polygon or different choice of a pole, O . But if the order of forces be taken as above, *as they occur along the beam, or structure, and the pole taken at the "butt" of the first force in the force polygon, there will be only one ; (and this one will be called the special equilibrium polygon in the chapter on arch-ribs, and the "true linear arch" in dealing with the stone arch.)* After the rays (dotted in Fig. 351) have been added, by joining the pole to each

vertex with which it is not already connected, the final figure may be called the *force diagram*.

It may sometimes be convenient to give the name of rays to the two forces of the force polygon which meet at the pole, in which case the first and last segments of the corresponding equil. polygon will coincide with the lines of action of those forces in the *space-diagram* (as we may call the representation of the body or structure on which the forces act). This "space diagram" shows the real field of action of the forces, while the force diagram, which may be placed in any convenient position on the paper, shows the *magnitudes* and directions of the forces acting in the former diagram, its lines being interpreted on a scale of so many *lbs.* or *tons* to the inch of paper; in the space-diagram we deal with a scale of so many *feet* to the inch of paper.

We have found, then, that if any vertex or corner of the closed force polygon be taken as a pole, and rays drawn from it to all the other corners of the polygon, and a corresponding equil. polygon drawn in the space diagram, the first and last segments of the latter polygon must co-incide with the first and last forces according to the order adopted (or with the resultants of the first two and last two, if more convenient to classify them thus). It remains to utilize this principle.

327. To Find the Resultant of Several Forces in a Plane.—This might be done as in § 326, but since frequently a given set of forces are parallel, or nearly so, a special method will now be given, of great convenience in such cases. Fig. 352.

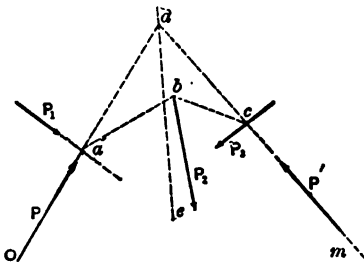

FIG. 352.

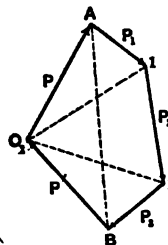

FIG. 353.

Let P_1 , P_2 , and P_3 be the given forces whose resultant is required. Let us first find their *anti-resultant*, or force which will balance

them. This anti-resultant may be conceived as decomposed into two components P and P' one of which, say P , is arbitrary in amount and position. Assuming P , then, at convenience, in the space diagram, it is required to find P' . The five forces must form a balanced system; hence if beginning at O_1 , Fig. 353, we lay off a line $O_1A = P$ by scale, then $A1 =$ and \parallel to P_1 , and so on (point to butt), the line BO_1 necessary to close the force polygon is $= P'$ required. Now form the corresponding equil. polygon in the space diagram in the usual way, viz.: through a the intersection of P and P_1 draw $ab \parallel$ to the ray $O_1 \dots 1$ (which connects the pole O_1 with the point of the last force mentioned). From b , where ab intersects the line of P_2 , draw bc, \parallel to the ray $O_1 \dots 2$, till it intersects the line of P_3 . A line mc drawn through c and \parallel to the P' of the force diagram is the line of action of P' .

Now the resultant of P and P' is the anti-resultant of P_1, P_2 and P_3 ; $\therefore d$, the intersection of the lines of P and P' , is a point in the line of action of the anti-resultant required, while its direction and magnitude are given by the line BA in the force diagram; for BA forms a closed polygon both with P_1, P_2, P_3 , and with PP' . Hence a line through $d \parallel$ to BA , viz., de , is the line of action of the anti-resultant (and hence of the resultant) of P_1, P_2, P_3 .

Since, in this construction, P is arbitrary, we may first choose O_1 , arbitrarily, in a convenient position, i.e., in such a position that by inspection the segments of the resulting equil. polygon shall give fair intersections and not pass off the paper. If the given forces are parallel the device of introducing the oblique P and P' is quite necessary.

328.—The result of this construction may be stated as follows, (regarding Oa and cm as segments of the equil. polygon as well as ab and bc): *If any two segments of an equil. polygon be prolonged, their intersection is a point in the line of action of the resultant of those forces acting at*

the vertices intervening between the given segments. Here, the resultant of P_1, P_2, P_3 , acts through d .

329. Vertical Reaction of Piers, etc.—Fig. 354. Given the vertical forces or loads P_1, P_2 , and P_3 acting on a rigid body (beam, or truss) which is supported by two piers having smooth horizontal surfaces (so that the reactions must be vertical), required the reactions V_0 and V_n of the piers. For an instant suppose V_0 and V_n known; they are in

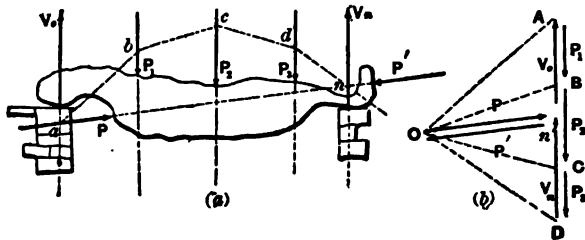

FIG. 354.

equil. with P_1, P_2 , and P_3 . The introduction of the equal and opposite forces P and P' in the same line will not disturb the equilibrium. Taking the seven forces in the order $P, V_0, P_1, P_2, P_3, V_n$, and P' , a force polygon formed with them will close (see (b) in Fig. where the forces which really lie on the same line are slightly separated). With O , the butt of P , as a pole, draw the rays of the force diagram OA, OB , etc. The corresponding equil. polygon begins at a , the intersection of P and V_0 in (a) (the space diagram), and ends at n the intersection of P' and V_n . Join an . Now since P and P' act in the same line, an must be that line and must be \parallel to P and P' of the force diagram. Since the amount and direction of P and P' are arbitrary, the position of the pole O is arbitrary, while P_1, P_2 , and P_3 are the only forces known in advance in the force diagram.

Hence V_0 and V_n may be determined as follows: Lay off the given loads P_1, P_2 , etc., in the order of their occurrence in the space diagram, to form a "load-line" AD

(see (b.) Fig. 354) as a beginning for a force-diagram; take any convenient pole O , draw the rays OA, OB, OC and OD . Then beginning at any convenient point a in the vertical line containing the unknown V_0 , draw $ab \parallel$ to OA , $bc \parallel$ to OB , and so on, until the last segment (dn in this case) cuts the vertical containing the unknown V_n in some point n . Join an (this is sometimes called a *closing line*) and draw a \parallel to it through O , in the force-diagram. This last line will cut the "load-line" in some point n' , and divide it in two parts $n'A$ and Dn' , which are respectively V_0 and V_n required.

Corollary.—Evidently, for a given system of loads, in given vertical lines of action, and for two given piers, or abutments, having *smooth horizontal surfaces*, the location of the point n' on the load line is *independent of the choice of a pole*.

Of course, in treating the stresses and deflection of the rigid body concerned, P and P' are left out of account, as being imaginary and serving only a temporary purpose.

330. Application of Foregoing Principles to a Roof Truss.—
Fig. 355. W_1 and W_2 are wind pressures, P_1 and P_2 are loads, while the remaining external forces, viz., the re-

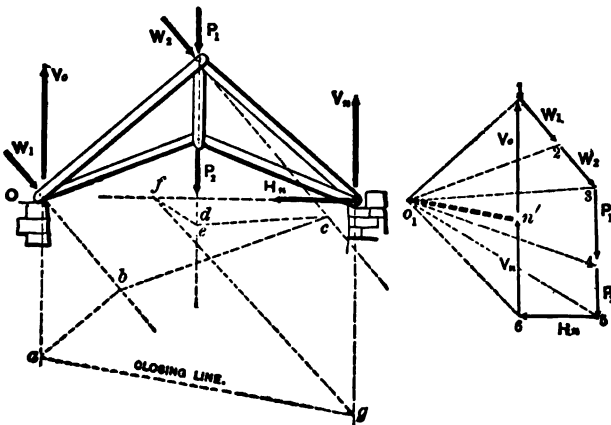

FIG. 355.

actions, or supporting forces, V_o , V_n and H_n , may be found by preceding §§. (We here suppose that the right abutment furnishes all the horizontal resistance; none at the left).

Lay off the forces (known) W_1 , W_2 , P_1 , and P_2 in the usual way, to form a portion of the closed force polygon. To close the polygon it is evident we need only draw a horizontal through 5 and limit it by a vertical through 1. This determines H_n but it remains to determine n' the point of division between V_o and V_n . Select a convenient pole O_1 , and draw rays from it to 1, 2, etc. Assume a convenient point a in the line of V_o in the space diagram, and through it draw a line \parallel to O_11 to meet the line of W_1 in some point b ; then a line \parallel to O_12 to meet the line of W_2 in some point c ; then through c \parallel to O_13 to meet the line of P_1 in some point d ; then through d \parallel to O_14 to meet the line of P_2 in some point e , (e is identical with d , since P_1 and P_2 are in the same line); then ef \parallel to O_15 to meet H_n in some point f ; then fg \parallel to O_16 to meet V_n in some point g .

$abcdefg$ is an equilibrium polygon corresponding to the pole O_1 .

Now join ag , the "closing-line," and draw a \perp to it through O_1 to determine n' , the required point of division between V_o and V_n on the vertical 1 6. Hence V_o and V_n are now determined as well as H_n .

[The use of the arbitrary pole O_1 implies the temporary employment of a pair of opposite and equal forces in the line ag , the amount of either being $= O_1n'$].

Having now all the external forces acting on the truss, and assuming that it contains no "redundant parts," i.e., parts unnecessary for rigidity of the frame-work, we proceed to find the pulls and thrusts in the individual pieces, on the following plan. The truss being *pin-connected*, no piece extending beyond a joint, and all loads being considered to act at joints, the action, pull or thrust, of each piece on the joint at either extremity will be in the direction of the piece, i.e., in a *known direction*, and the pin of each

joint is in equilibrium under a system of concurrent forces consisting of the loads (if any) at the joint and the pulls or thrusts exerted upon it by the pieces meeting there. Hence we may apply the principles of § 325 to each joint in turn. See Fig. 356. In constructing and interpreting the various force polygons, Mr. R. H Bow's convenient notation will be used; this is as follows: In the space diagram a capital letter [ABC , etc.] is placed in each triangular cell of the truss, and also in each angular space in the outside outline of the truss between the external forces and the adjacent truss-pieces. In this way we can speak of the force W_1 as the force BC , of W_2 as the force CE , the stress in the piece $a\beta$ as the force CD , and so on. That is, the stress in any one piece can be named from the letters in the spaces bordering its two sides. Corresponding to these capital letters in the *spaces* of the space-diagram, small letters will be used at the *vertices* of the closed force-polygons (one polygon for each joint) in such a way that the stress in the piece CD , for example, shall be the force cd of the force polygon belonging to any joint in which that piece terminates; the stress in the piece FG by the force fg in the proper force polygon, and so on.

In Fig. 356 the whole truss is shown free, in equilibrium under the external forces. To find the pulls or thrusts (i.e., tensions or compressions) in the pieces, consider that if all but two of the forces of a closed force polygon are known in magnitude and direction, while the directions, only, of those two are known, the *whole force polygon may be drawn*, thus determining the *amounts* of those two forces by the lengths of the corresponding sides.

We must \therefore begin with a joint where no more than two pieces meet, as at a ; [call the joints a, β, γ, δ , and the corresponding force polygons a', β' etc. Fig. 356.] Hence at a' (anywhere on the paper) make $ab \parallel$ and $=$ (by scale) to the known force AB (i.e., V_o) *pointing it at the upper end*, and from this end draw $bc =$ and \parallel to the known force BC (i.e., W_1) *pointing this at the lower end*.

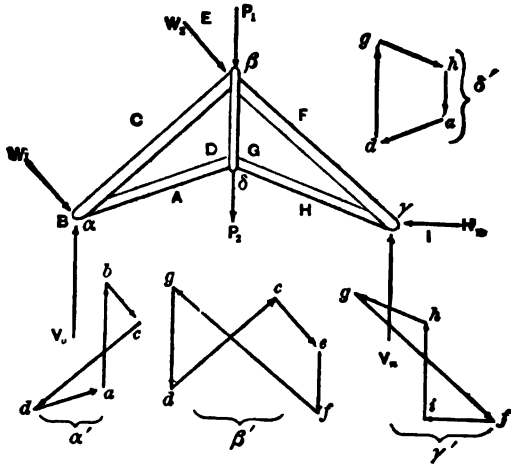

FIG 356.

To close the polygon draw through c a \parallel to the piece CD , and through a a \parallel to AD ; their intersection determines d , and the polygon is closed. Since the arrows must be point to butt round the periphery, the force with which the piece CD acts on the pin of the joint a is a force of an amount $= cd$ and in a direction from c toward d ; hence the piece CD is *in compression*; whereas the action of the piece DA upon the pin at a is from d toward a (direction of arrow) and hence DA is *in tension*. Notice that in constructing the force polygon a' a right-handed (or clock-wise) rotation has been observed in considering in turn the spaces $A B C$ and D , round the joint a . A similar order will be found convenient in each of the other joints.

Knowing now the stress in the piece CD , (as well as in DA) all but two of the forces acting on the pin at the joint β are known, and accordingly we begin a force polygon, β' , for that joint by drawing dc , $=$ and \parallel to the dc of polygon a' , but pointed in the opposite direction, since the action of CD on the joint β is equal and opposite to its action on the joint a (this disregards the weight of the piece). Through c draw $ce =$ and \parallel to the force CE (i.e., W_2) and

pointing the same way; then ef , = and \parallel to the load EF (i.e. P_1) and pointing downward. Through f draw a \parallel to the piece FG and through d , a \parallel to the piece GD , and the polygon is closed, thus determining the stresses in the pieces FG and GD . Noting the pointing of the arrows, we readily see that FG is in compression while GD is in tension.

Next pass to the joint d , and construct the polygon d' , thus determining the stress gh in GH and that ad in AD ; this last force ad should check with its equal and opposite ad already determined in polygon a' . Another check consists in the proper closing of the polygon γ' , all of whose sides are now known.

[A compound stress-diagram may be formed by superposing the polygons already found in such a way as to make equal sides co-incide; but the character of each stress is not so readily perceived then as when they are kept separate].

In a similar manner we may find the stresses in any pin-connected frame-work (in one plane and having no redundant pieces) under given loads, provided all the supporting forces or reactions can be found. In the case of a

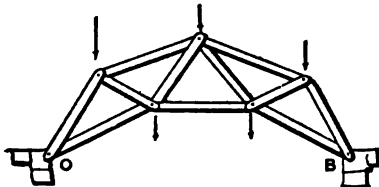

FIG. 357.

braced-arch (truss) as shown in Fig. 357, hinged to the abutments at both ends and not free to slide laterally upon them, the reactions at O and B depend, in amount and direction,

not only upon the equations of Statics, but on the form and elasticity of the arch-truss. Such cases will be treated later under arch-ribs, or curved beams.

332. The Special Equil. Polygon. Its Relation to the Stresses in the Rigid Body.—Reproducing Figs. 350 and 351 in Figs. 358 and 359, (where a rigid curved beam is in equilibrium under the forces P_1, P_2, P_3, P_4 and R'_c) we call $a \dots b \dots c$

the *special equil. polygon* because it corresponds to a force diagram in which the same order of forces has been observed as that in which they occur along the beam (from left to right here). From the relations between the force

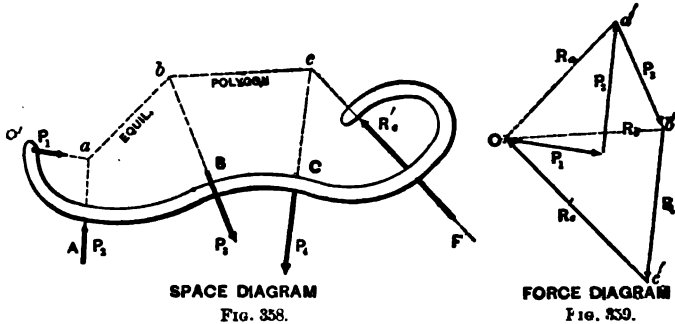
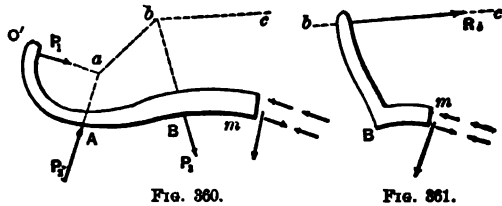

diagram and equil. polygon, this *special equil. polygon* in the space diagram has the following properties in connection with the corresponding rays (dotted lines) in the force diagram.

The stresses in any cross-section of the portion $O'A$ of the beam, are due to P_1 alone; those of any cross-section on AB to P_1 and P_2 , i.e., to *their resultant* R_1 , whose magnitude is given by the line Oa' in the force diagram, while its line of action is ab the first segment of the equil. polygon. Similarly, the stresses in BC are due to P_1 , P_2 and P_3 , i.e., to their resultant R_2 , acting along the segment bc , its magnitude being $=Ob'$ in the force diagram. E.g., if the section at m be exposed, considering $O'ABm$ as a free body, we have (see Fig. 360) the elastic stresses (or inter-



nal forces) at m balancing the exterior or "applied forces" P_1 , P_2 and P_3 . Obviously, then, the stresses at m are just

the same as if R_b , the resultant of P_1 , P_2 and P_3 , acted upon an imaginary rigid prolongation of the beam intersecting bc (see Fig. 361). R_b might be called the "anti-stress-resultant" for the portion BC of the beam. We may \therefore state the following: *If a rigid body is in equilibrium under a system of Non-Concurrent Forces in a plane, and the special equilibrium polygon has been drawn, then each ray of the force diagram is the anti-stress-resultant of that portion of the beam which corresponds to the segment of the equilibrium polygon to which the ray is parallel; and its line of action is the segment just mentioned.*

Evidently if the body is not one rigid piece, but composed of a ring of uncemented blocks (or voussoirs), it may be considered rigid only so long as no slipping takes place or disarrangement of the blocks; and this requires that the "anti-stress-resultant" for a given joint between two blocks shall not lie outside the bearing surface of the joint, nor make too small an angle with it, lest tipping or slipping occur. For an example of this see Fig. 362, showing a line of three blocks in equilibrium under five forces.

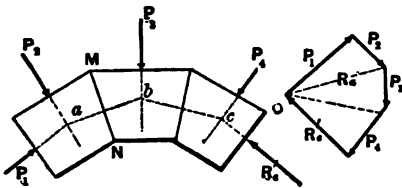

FIG. 362.

The pressure borne at the joint MN , is $= R_a$ in the force-diagram and acts in the line ab . The construction supposes all the forces given except one, in amount and position,

and that this one could easily be found in *amount*, as being the side remaining to close the force polygon, while its *position* would depend on the equil. polygon. But in practice the *two* forces P_1 and R'_1 are generally unknown, hence the point O , or pole of the force diagram, can not be fixed, nor the special equil. polygon located, until other considerations, outside of those so far presented, are brought into play. In the progress of such a problem, as will be seen, it will be necessary to use arbitrary *trial* positions for the pole O , and corresponding *trial* equilibrium polygons.

CHAPTER IX.

GRAPHICAL STATICS OF VERTICAL FORCES.

333. **Remarks.**—(With the exception of § 378 *a*) in problems to be treated subsequently (either the stiff arch-rib, or the block-work of an arch-ring, of masonry) when the body is considered *free* all the forces holding it in equil. will be *vertical* (loads, due to gravity) except the reactions at the two extremities, as in Fig. 363; but for convenience each reaction will be replaced by its horizontal and vertical components (see Fig. 364). The two *H*'s are of course equal, since they are the only horizontal forces in the system. Henceforth, all *equil. polygons* under discussion will be understood to imply this kind of system of forces. $P_1, P_2,$

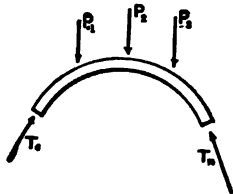

FIG. 363.

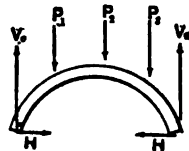

FIG. 364.

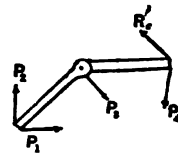

FIG. 364a.

etc., will represent the "loads"; V_0 and V_n the vertical components of the abutment reactions; H the value of either horizontal component of the same. (We here suppose the pressures T_0 and T_n resolved along the horizontal and vertical.)

334. Concrete Conception of an Equilibrium Polygon.—Any equilibrium polygon has this property, due to its mode of construction, viz.: If the ab and bc of Fig. 358 were imponderable straight rods, jointed at b without friction, they would be in equilibrium under the system of forces there given. (See Fig. 364a). The rod ab suffers a compression equal to the R_a of the force diagram, Fig. 359, and bc a compression = R_b . In some cases these rods might be in tension, and would then form a set of links playing the part of a suspension-bridge cable. (See § 44).

335. Example of Equilibrium Polygon Drawn to Vertical Loads—Fig. 365. [The structure bearing the given loads is not shown, but simply the imaginary rods, or segments of an equilibrium polygon, which would support the given loads in equilibrium if the abutment points A and B , to which the terminal rods are hinged, were firm. In the present case this equilibrium is unstable since the rods form a *standing structure*; but if they were *hanging*, the equilibrium would be *stable*. Still, in the present case, a *very light bracing*, or a little friction at all joints would make the equilibrium stable.

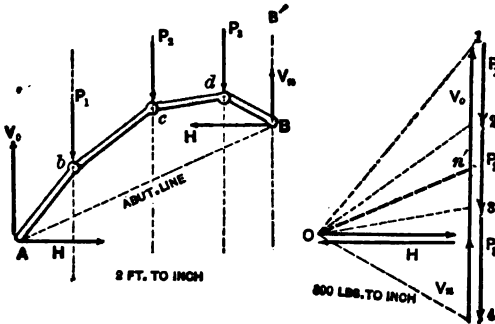

FIG. 365.

Given three loads P_1 , P_2 , and P_3 , and two "abutment verticals" A' and B' , in which we desire the equil. polygon to terminate, lay off as a "load-line," to scale, P_1 , P_2 , and P_3 end to end in their order. Then selecting any pole,

O , draw the rays $O1, O2$, etc., of a force diagram (the V 's and P 's, though really on the same vertical, are separated slightly for distinctness; also the H 's, which both pass through O and divide the load-line into V_0 and V_n). We determine a corresponding equilibrium polygon by drawing through A (any point in A') a line \parallel to $O \dots 1$, to intersect P_1 in some point b ; through b a \parallel to $O \dots 2$, and so on until B' the other abutment-vertical is struck in some point B . AB is the "abutment-line" or "closing-line."

By choosing another point for O , another equilibrium polygon would result. As to which of the infinite number (which could thus be drawn, for the given loads and the A' and B' verticals) is the *special equilibrium polygon* for the arch-rib or stone-arch, or other structure; on which the loads rest, is to be considered hereafter. In any of the above equilibrium polygons the imaginary series of jointed rods would be in equilibrium.

336. Useful Property of an Equilibrium Polygon for Vertical Loads.—(Particular case of § 328). See Fig. 366. In any equil. polygon, supporting vertical loads, consider as free any number of consecutive segments, or rods, with the loads at their joints, e. g., the 5th and 6th and portions of the 4th and 7th which, we suppose cut and the compressive forces in them put in, T_4 and T_7 , in order to consider 4 5 6 7 as a free body. For equil., according to Statics, the lines of action of T_4 and T_7 (the compression in those rods) must intersect in a point, O , in the line of action of the resultant of P_4, P_5 , and P_6 ; i. e., of the loads occurring at the intervening vertices. That is, the point C must lie in the vertical containing the centre of gravity of those loads. Since the position of this vertical must be independent of the particular equilibrium polygon used, any other (dotted lines in Fig. 366) for the same loads will give the same re-

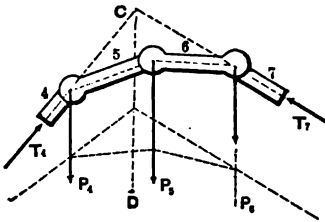

FIG. 366.

intersect in a point, O , in the line of action of the resultant of P_4, P_5 , and P_6 ; i. e., of the loads occurring at the intervening vertices. That is, the point C must lie in the vertical containing the centre of gravity of those loads. Since the position of this vertical must be independent of the particular equilibrium polygon used, any other (dotted lines in Fig. 366) for the same loads will give the same re-

sults. Hence the vertical CD , containing the centre of gravity of any number of consecutive loads, is easily found by drawing the equilibrium polygon corresponding to any convenient force diagram having the proper load-line.

This principle can be advantageously applied to finding a gravity-line of any plane figure, by dividing the latter into parallel strips, whose areas may be treated as loads applied in their respective centres of gravity. If the strips are quite numerous, the centre of gravity of each may be considered to be at the centre of the line joining the middles of the two long sides, while their areas may be taken as proportional to the lengths of the lines drawn through these centres of gravity parallel to the long sides and limited by the end-curves of the strips. Hence the "load-line" of the force diagram may consist of these lines, or of their halves, or quarters, etc., if more convenient (§ 376).

USEFUL RELATIONS BETWEEN FORCE DIAGRAMS AND EQUILIBRIUM POLYGONS.

(for vertical loads.)

337. Résumé of Construction.—Fig. 367. Given the loads P_1 , etc., their verticals, and the two abutment verticals A' and B' , in which the abutments are to lie; we lay off a load-line 1 . . . 4, take any convenient pole, O , for a force-diagram and complete the latter. For a corresponding equilibrium polygon, assume any point A in the vertical A' , for an abutment, and draw the successive segments $A1, 2$, etc., respectively parallel to the inclined lines of the force diagram (rays), thus determining finally the abutment B , in B' , which (B) will not in general lie in the horizontal through A .

Now join AB , calling AB the abutment-line, and draw a parallel to it through O , thus fixing the point n' on the

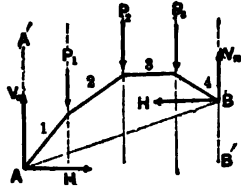

FIG. 367.

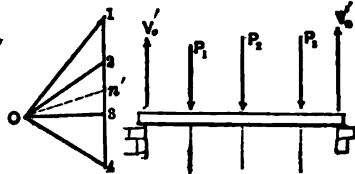

FIG. 368.

load-line. This point n' , as above determined, is *independent of the location of the pole, O* , (proved in § 329) and divides the load-line into two portions ($V'_0 = 1 \dots n'$, and $V'_n = n' \dots 4$) which are the vertical pressures which two supports in the verticals A' and B' would sustain if the given loads rested on a horizontal rigid bar, as in Fig. 368.

See § 329. Hence to find the point n' we may use *any convenient pole O* .

[N. B.—The forces V_0 and V_n of Fig. 367 are not identical with V'_0 and V'_n , but may be obtained by dropping a \perp from O to the load-line, thus dividing the load-line into two portions which are V_0 (upper portion) and V_n . However, if A and B be connected by a *tie-rod*, in Fig. 367, the abutments in that figure will bear vertical pressures only and they will be the same as in Fig. 368, while the tension in the tie-rod will be $= On'$.]

338. Theorem.—*The vertical dimensions of any two equilibrium polygons, drawn to the same loads, load-verticals, and abutment-verticals, are inversely proportional to their H 's (or "pole distances").* We here regard an equil. polygon and its abutment-line as a closed figure. Thus, in Fig. 369, we have two force-diagrams (with a common load-line, for convenience) and their corresponding equil. polygons, for the same loads and verticals. From § 337 we know that On' is \parallel to AB and $O_n n'$ is \parallel to $A_n B_n$. Let CD be any vertical cutting the first segments of the two equil. polygons.

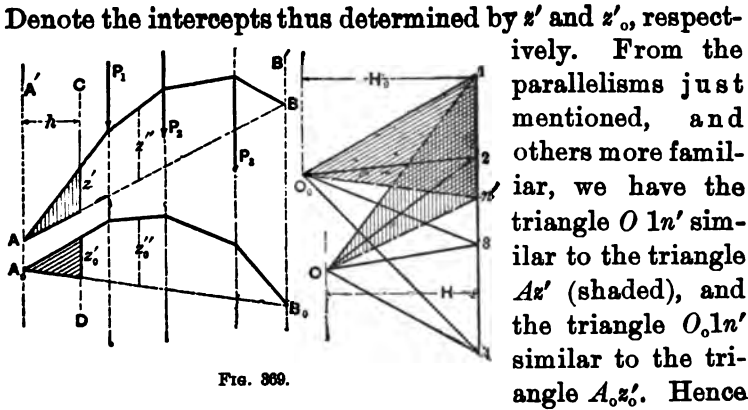

the proportions between $\left\{ \frac{ln'}{H} = \frac{z'}{h} \text{ and } \frac{ln'}{H_0} = \frac{z'_0}{h} \right\}$
 bases and altitudes

$\therefore z' : z'_0 :: H_0 : H$. The same kind of proof may easily be applied to the vertical intercepts in any other segments, e. g., z'' and z''_0 . Q. E. D.

339. Corollaries to the foregoing. It is evident that:

(1.) If the pole of the force-diagram be moved along a vertical line, the equilibrium polygon changing its form in a corresponding manner, the vertical dimensions of the equilibrium polygon remain unchanged; and

(2.) If the pole move along a straight line which contains the point n' , the direction of the abutment-line remains constantly parallel to the former line, while the vertical dimensions of the equilibrium polygon change in inverse proportion to the pole distance, or H , of the force-diagram. [H is the \perp distance of the pole from the load-line, and is called the pole-distance].

§ 340. Linear Arch as Equilibrium Polygon.—(See § 316.) If the given loads are infinitely small with infinitely small horizontal spaces between them, any equilibrium polygon becomes a linear arch. Graphically we can not deal with these infinitely small loads and spaces, but from § 336 it is evident that if we replace them, in successive groups,

by finite forces, each of which = the sum of those com-

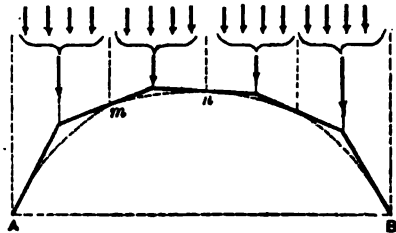

FIG. 370.

posing one group and is applied through the centre of gravity of that group, we can draw an equilibrium polygon whose segments will be tangent to the curve of the corresponding linear arch, and indicate its position with sufficient exactness for practical purposes. (See Fig. 370). The successive points of tangency $A, m, n,$ etc., lie vertically under the points of division between the groups. This relation forms the basis of the graphical treatment of voussoir, or blockwork, arches.

341. To Pass an Equilibrium Polygon Through Three Arbitrary Points.—(In the present case the forces are vertical. For a construction dealing with any plane system of forces see construction in § 378a.) Given a system of loads, it is required to draw an equilibrium polygon for them through any three points, two of which may be considered as abut-

ments, outside of the load-verticals, the third point being between the verticals of the first two. See Fig. 371. The loads $P_1,$ etc., are given, with their verticals, while $A, p,$ and B are the three points. Lay off the load-line, and with any convenient pole, $O_1,$ construct a force-diagram, then a corresponding preliminary equilibrium polygon beginning at $A.$ Its right abutment $B_1,$ in the vertical through $B,$ is thus found. $O_1 n'$ can now be drawn \parallel to $AB_1,$ to determine $n'.$ Draw $n'O \parallel$ to $BA.$ The pole of the required equilibrium polygon must lie on $n'O$ (§ 337)-

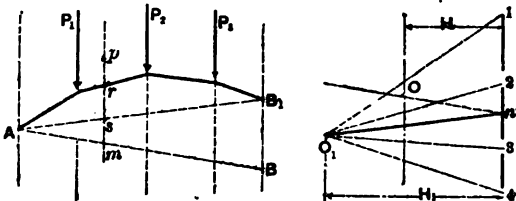

FIG. 371.

ments, outside of the load-verticals, the third point being between the verticals of the first two. See Fig. 371. The loads $P_1,$ etc., are given, with their verticals, while $A, p,$ and B are the three points. Lay off the load-line, and with any convenient pole, $O_1,$ construct a force-diagram, then a corresponding preliminary equilibrium polygon beginning at $A.$ Its right abutment $B_1,$ in the vertical through $B,$ is thus found. $O_1 n'$ can now be drawn \parallel to $AB_1,$ to determine $n'.$ Draw $n'O \parallel$ to $BA.$ The pole of the required equilibrium polygon must lie on $n'O$ (§ 337)-

Draw a vertical through p . The H of the required equilibrium polygon must satisfy the proportion $H : H_1 :: \overline{rs} : \overline{pm}$. (See § 338). Hence construct or compute H from the proportion and draw a vertical at distance H from the load-line (on the left of the load-line here); its intersection with $n' O$ gives O the desired pole, for which a force diagram may now be drawn. The corresponding equilibrium polygon beginning at the first point A will also pass through p and B ; it is not drawn in the figure.

342. Symmetrical Case of the Foregoing Problem.—If two points A and B are on a level, the third, p , on the middle vertical between them; and the loads (an even number) symmetrically disposed both in position and magnitude, about p , we may proceed more simply, as follows: (Fig. 372).

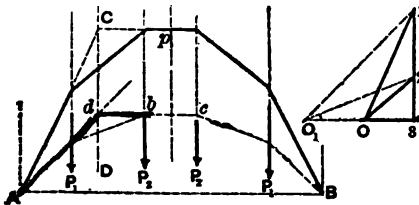

FIG. 372.

From symmetry n' must occur in the middle of the load-line, of which we need lay off only the upper half. Take a convenient pole O_1 in the horizontal

through n' , and draw a half force diagram and a corresponding half equilibrium polygon (both dotted). The upper segment bc of the latter must be horizontal and being prolonged, cuts the prolongation of the first segment in a point d , which determines the vertical CD containing the centre of gravity of the loads occurring over the half-span on the left. (See § 336). In the required equilibrium polygon the segment containing the point p must be horizontal, and its intersection with the first segment must lie in CD . Hence determine this intersection, C , by drawing the vertical CD and a horizontal through p ; then join CA , which is the *first segment* of the required equil. polygon. A parallel to CA through 1 is the *first ray* of the corresponding force diagram, and determines the pole O on the horizontal through n' . Completing the force diagram for

this pole (half of it only here), the required equil. polygon is easily finished afterwards.

343. To Find a System of Loads Under Which a Given Equilibrium Polygon Would be in Equilibrium.—Fig. 373. Let AB be the given equilibrium polygon. Through any point O

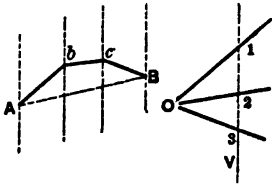

FIG. 373.

as a pole draw a parallel to each segment of the equilibrium polygon. Any vertical, as V , cutting these lines will have, intercepted upon it, a load-line 1, 2, 3, whose parts 1..2, 2..3, etc., are proportional to the successive loads which, placed on the corresponding joints of the equilibrium polygon would be supported by it in equilibrium (unstable).

One load may be assumed and the others constructed.

A hanging, as well as a standing, equilibrium polygon may be dealt with in like manner, but will be in *stable* equilibrium. The problem in § 44 may be solved in this way.

CHAPTER X.

RIGHT ARCHES OF MASONRY.

344.—In an ordinary “right” stone-arch (i.e., one in which the faces are \perp to the axis of the cylindrical soffit, or under surface), the successive blocks forming the arching are called *voussoirs*, the joints between them being planes which, prolonged, meet generally in one or more horizontal lines; e.g., those of a three-centred arch in three \parallel horizontal lines; those of a circular arch in one, the axis of the cylinder, etc. Elliptic arches are sometimes used. The inner concave surface is called the *soffit*, to which the radiating joints between the *voussoirs* are made perpendicular. The curved line in which the soffit is intersected by a plane

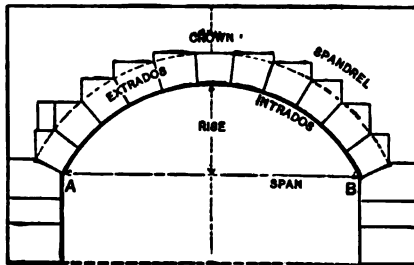

FIG. 374.

\perp to the axis of the arch is the *Intrados*. The curve in the same plane as the intrados, and bounding the outer extremities of the joints between the *voussoirs*, is called the *Extrados*.

Fig. 374 gives other terms in use in connection with a

stone arch, and explains those already given. AB is the "springing-line."

345. Mortar and Friction.—As common mortar hardens very slowly, no reliance should be placed on its tenacity as an element of stability in arches of any considerable size; though hydraulic mortar and *thin* joints of ordinary mortar can sometimes be depended on. *Friction*, however, between the surfaces of contiguous voussoirs, plays an essential part in the stability of an arch, and will therefore be considered.

The stability of voussoir-arches must \therefore be made to depend on the resistance of the voussoirs to compression and to sliding upon each other; as also of the blocks composing the piers, the foundations of the latter being firm.

346. Point of Application of the Resultant Pressure between two consecutive voussoirs; (or pier blocks). Applying Navier's principle (as in flexure of beams) that the pressure per unit area on a joint varies uniformly from the extremity under greatest compression to the point of least compression (or of no compression); and remembering that negative pressures (i.e., tension) can not exist, as they might in a curved beam, we may represent the pressure per unit area at successive points of a joint (from the intrados toward the extrados, or vice versâ) by the ordinates of a straight line, forming the surface of a trapezoid or triangle, in which figure the foot of the ordinate of the centre of gravity is the *point of application of the resultant pressure*. Thus, where the least compression is supposed

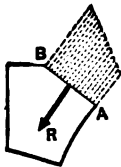

FIG. 375.

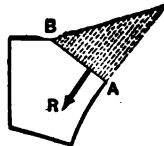

FIG. 376.

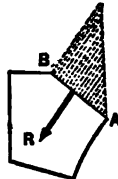

FIG. 377.

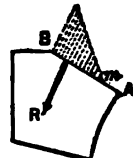

FIG. 378.

to occur at the intrados *A*, Fig. 375, the pressures vary as the ordinates of a trapezoid, increasing to a maximum value at *B*, in the extrados. In Fig. 376, where the pressure is zero at *B*, and varies as the ordinates of a *triangle*, the resultant pressure acts through a point *one-third* the joint-length from *A*. Similarly in Fig. 377, it acts one-third the joint-length from *B*. Hence, when the pressure is not zero at either edge the resultant pressure acts within the middle third of the joint. Whereas, if the resultant pressure falls *without* the middle third, it shows that a portion *Am* of the joint, see Fig. 378, receives no pressure, i.e., the joint tends to open along *Am*.

Therefore that no joint tend to open, the resultant pressure must *fall within the middle third*.

It must be understood that the joint surfaces here dealt with are rectangles, seen edgewise in the figures.

347. Friction.—By experiment it has been found the angle of friction (see § 156) for two contiguous voussoirs of stone or brick is about 30° ; i.e., the coefficient of friction is $f = \tan. 30^\circ$. Hence if the direction of the pressure exerted upon a voussoir by its neighbor makes an angle α less than 30° with the *normal to the joint surface*, there is no danger of rupture of the arch by the sliding of one on the other. (See Fig. 379).

348. Resistance to Crushing.—When the resultant pressure falls at its extreme allowable limit, viz.: the edge of the middle third, the pressure per unit of area at *n*, Fig. 380, is double the mean pressure per unit of area. Hence, in designing an arch of masonry, we must be assured that at every joint (taking 10 as a factor of safety)

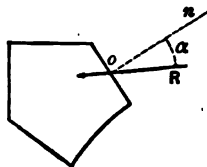

FIG. 379.

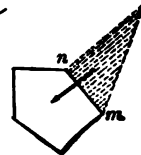

FIG. 380.

{ Double the mean press- } must be less than $\frac{1}{10} O$
 { ure per unit of area }

C being the ultimate resistance to crushing, of the material employed (§ 201) (Modulus of Crushing).

Since a lamina *one foot* thick will always be considered in what follows, careful attention must be paid to the units employed in applying the above tests.

EXAMPLE.—If a joint is 3 ft. by 1 foot, and the resultant pressure is 22.5 tons the mean pressure per sq. foot is

$$p=22.5 \div 3=7.5 \text{ tons per sq. foot}$$

\therefore its double=15 tons per sq. foot=208.3 lbs. sq. inch, which is much less than $\frac{1}{10}$ of C for most building stones; see § 203, and below.

At joints where the resultant pressure falls at the middle, the max. pressure per square inch would be equal to the mean pressure per square inch; but for safety it is best to assume that, at times, (from moving loads, or vibrations) it may move to the edge of the middle third, causing the max. pressure to be double the mean (per square inch).

Gen. Gillmore's experiments in 1876 gave the following results, among many others:

NAME OF BUILDING STONE.	C IN LBS. PER SQ. INCH.
Berea sand-stone, 2-inch cube, - - - -	8955
" " 4 " " - - - -	11720
Limestone, Sebastopol, 2-inch cube (<i>chalk</i>), - -	1075
Limestone from Caen, France, - - - -	3650
Limestone from Kingston, N. Y., - - - -	13900
Marble, Vermont, 2-inch cube, - - -	8000 to 13000
Granite, New Hampshire, 2-inch cube, - - -	15700 to 24000

349. The Three Conditions of Safe Equilibrium for an arch of uncemented voussoirs.

Recapitulating the results of the foregoing paragraphs, we may state, as follows, the three conditions which must be satisfied at every joint of arch-ring and pier, for each of any possible combination of loads upon the structure:

- (1). The resultant pressure must pass within the middle-third.
- (2). The resultant pressure must not make an angle $> 30^\circ$ with the normal to the joint.
- (3). The mean pressure per unit of area on the surface

of the joint must not exceed $\frac{1}{20}$ of the Modulus of crushing of the material.

350. The True Linear-Arch, or Special Equilibrium Polygon; and the resultant pressure at any joint. Let the weight of each voussoir and its load be represented by a vertical force passing through the centre of gravity of the two, as in Fig. 381. Taking any two points A and B , A being in the first joint and B in the last; also a third point, p , in the crown joint (supposing such to be there, although generally a key-stone occupies the crown), through these

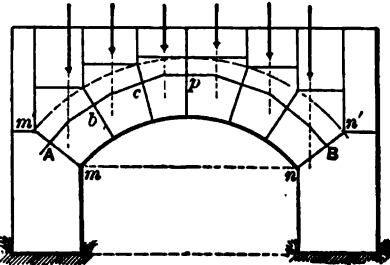

FIG. 381.

three points can be drawn [§ 341] an equilibrium polygon for the loads given; suppose this equil. polygon nowhere passes outside of the arch-ring (the arch-ring is the portion between the intrados, mn , and the (dotted) extrados $m'n'$) intersecting the joints at b , c , etc. Evidently if such be the case, and small metal rods (not round) were inserted at A , b , c , etc., so as to separate the arch-stones slightly, the arch would stand, though in unstable equilibrium, the piers being firm; and by a different choice of A , p , and B , it might be possible to draw other equilibrium polygons with segments cutting the joints within the arch-ring, and if the metal rods were shifted to these new intersections the arch would again stand (in unstable equilibrium).

In other words, if an arch stands, it may be possible to draw a great number of linear arches within the limits of the arch-ring, since three points determine an equilibrium polygon (or linear arch) for given loads. The question arises then: *which linear arch is the locus of the actual resultant pressures at the successive joints?*

[Considering the arch-ring as an elastic curved beam inserted in firm piers (i.e., the blocks at the springing-line

are incapable of turning) and having secured a close fit at all joints before the centering is lowered, the most satisfactory answer to this question is given in Prof. Greene's "Arches," p. 131; viz., to consider the arch-ring as an arch rib of fixed ends and no hinges; see § 380 of next chapter; but the lengthy computations there employed (and the method demands a simple algebraic curve for the arch) may be most advantageously replaced by Prof. Eddy's graphic method ("New Constructions in Graphical Statics," published in Van Nostrand's Magazine for 1877), which applies to arch curves of any form.

This method will be given in a subsequent chapter, on Arch Ribs, or Curved Beams; but for arches of masonry a much simpler procedure is sufficiently exact for practical purposes and will now be presented].

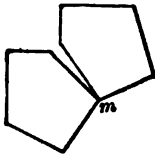

FIG. 382.

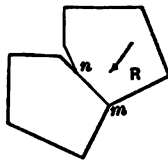

FIG. 383.

If two elastic blocks of an arch-ring touch at one edge, Fig. 382, their adjacent sides making a small angle with each other, and are then gradually pressed more and more forcibly together at the edge *m*, as the arch-ring settles, the centering being gradually lowered, the surface of contact becomes larger and larger, from the compression which ensues (see Fig. 383); while the resultant pressure between the blocks, first applied at the extreme edge *m*, has now probably advanced nearer the middle of the joint in the mutual adjustment of the arch-stones. With this in view we may reasonably deduce the following theory of the location of the true linear arch (sometimes called the "line of pressures" and "curve of pressure") in an arch under given loading and with *firm piers*. (Whether the piers are really unyielding, under the oblique thrusts at the springing-line, is a matter for subsequent investigation.

351. Location of the True Linear Arch.—Granted that the voussoirs have been closely fitted to each other over the

centering (sheets of lead are sometimes used in the joints to make a better distribution of pressure); and that the piers are firm; and that the arch can stand at all without the centering; then we assume that in the mutual accommodation between the voussoirs, as the centering is lowered, the resultant of the pressures distributed over any joint, if at first near the extreme edge of the joint, advances nearer to the middle as the arch settles to its final position of equilibrium under its load; and hence the following

352. Practical Conclusions.

I. If for a given arch and loading, with firm piers, an equilibrium polygon can be drawn (by proper selection of the points *A*, *p*, and *B*, Fig. 381) entirely within the *middle third* of the arch ring, not only will the arch stand, but the resultant pressure at every joint will be within the middle third (Condition 1, § 349); and among all possible equilibrium polygons which can be drawn within the middle third, that is the "true" one which most nearly coincides with the middle line of the arch-ring.

II. If (with firm piers, as before) no equilibrium polygon can be drawn within the middle third, and only one within the arch-ring at all, the arch may stand, but chipping and spawling are likely to occur at the edges of the joints. The design should \therefore be altered.

III. If no equilibrium polygon can be drawn within the arch-ring, the design of either the arch or the loading must be changed; since, although the arch may stand, from the resistance of the spandrel walls, such a stability must be looked upon as precarious and not countenanced in any large important structure. (Very frequently, in small arches of brick and stone, as they occur in buildings, the cement is so tenacious that the whole structure is virtually a single continuous mass).

When the "true" linear arch has once been determined, the amount of the resultant pressure on any joint is given by the length of the proper ray in the force diagram.

ARRANGEMENT OF DATA FOR GRAPHIC TREATMENT.

353. **Character of Load.**—In most large stone arch bridges the load (permanent load) does not consist exclusively of masonry up to the road-way but partially of earth filling above the masonry, except at the faces of the arch where the spandrel walls serve as retaining walls to hold the earth. (Fig. 384). If the intrados is a half circle or half-

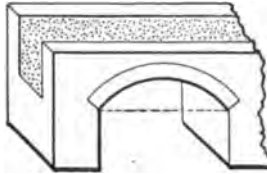

FIG. 384.

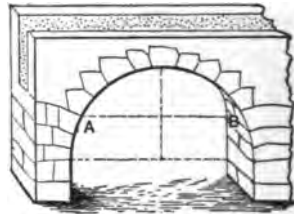

FIG. 385.

ellipse, a compactly-built masonry backing is carried up beyond the springing-line to AB about 60° to 45° from the crown, Fig. 385; so that the portion of arch ring below AB may be considered as part of the abutment, and thus AB is the virtual springing-line, for graphic treatment.

Sometimes, to save filling, small arches are built over the haunches of the main arch, with earth placed over them, as shown in Fig. 386. In any of the preceding cases

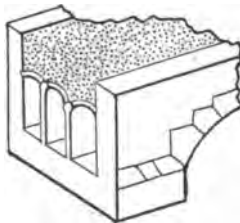

FIG. 386.

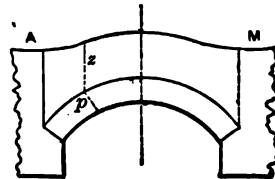

FIG. 387.

it is customary to consider that, on account of the bonding of the stones in the arch *shell*, the loading at a given distance from the crown is *uniformly distributed over the width of the roadway*.

354. Reduced Load-Contour.—In the graphical discussion of a proposed arch we consider a lamina one foot thick, this lamina being vertical and \perp to the axis of the arch; i.e., the lamina is \parallel to the spandrel walls. For graphical treatment, equal areas of the elevation (see Fig. 387) of this lamina must represent equal weights. Taking the material of the arch-ring as a standard, we must find for each point p of the extrados an imaginary height z of the arch-ring material, which would give the same pressure (per running horizontal foot) at that point as that due to the actual load above that point. A number of such ordinates, each measured vertically upward from the extrados determine points in the "Reduced Load-Contour," i.e., the imaginary line, AM , the area between which and the extrados of the arch-ring represents a homogeneous load of the same density as the arch-ring, and equivalent to the actual load (above extrados), *vertical by vertical*.

355. Example of Reduced Load-Contour.—Fig. 388. Given an arch-ring of granite (heaviness = 170 lbs. per cubic foot) with a dead load of rubble (heav. = 140) and earth (heav. = 100), distributed as in figure. At the point p , of the extrados, the depth 5 feet of rubble is equivalent to a depth of $[\frac{140}{170} \times 5] = 4.1$ ft. of granite, while the 6 feet of earth is equivalent to $[\frac{100}{170} \times 6] = 3.5$ feet of granite. Hence the Reduced Load-Contour has an ordinate, above p , of 7.6 feet. That is, for each of several points of the arch-ring extrados reduce the rubble ordinate in the ratio of 170 : 140, and the earth ordinate in the ratio 170 : 100 and add the results, setting off the sum vertically from the points in the extrados*. In this way Fig. 389 is obtained and the area

*This is most conveniently done by graphics, thus: On a right-line set off 17 equal parts (of any convenient magnitude.) Call this distance OA . Through O draw another right line at any convenient angle (30° to 60°) with OA , and on it from O

set off OB equal to 14 (for the rubble; or 10 for the earth) of the same equal parts. Join AB . From O toward A set off* all the rubble ordinates to be reduced, (each being set off from O) and through the other extremity of each draw a line parallel to AB . The reduced ordinates will be the respective lengths, from O , along OB , to the intersections of these parallels with OB .

* With the dividers.

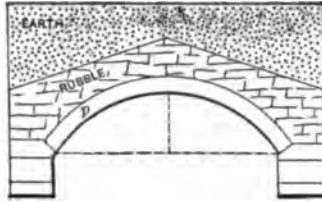

FIG. 388.

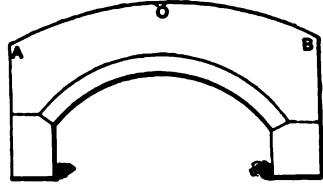

FIG. 389.

there given is to be treated as representing homogeneous granite one foot thick. This, of course, now includes the arch-ring also. AB is the "reduced load-contour."

356. Live Loads.—In discussing a railroad arch bridge the "live load" (a train of locomotives, e.g., to take an extreme case) can not be disregarded, and for each of its positions we have a separate **Reduced Load-Contour**.

EXAMPLE.—Suppose the arch of Fig. 388 to be 12 feet wide (not including spandrel walls) and that a train of locomotives weighing 3,000 lbs. per running foot of the track covers one half of the span. Uniformly* distributed laterally over the width, 12 ft., this rate of loading is equivalent to a masonry load of one foot high and a heaviness of 250 lbs. per cubic ft., i.e., is equivalent to a height of 1.4 ft. of granite masonry [since $\frac{20}{170} \times 1.0 = 1.4$] over the half span considered. Hence from Fig. 390 we obtain Fig. 391 in an obvious manner. Fig. 391 is now ready for graphic treatment.

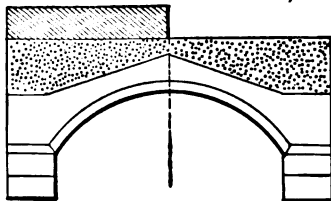

FIG. 390.

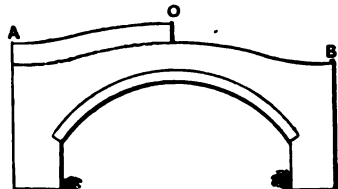

FIG. 391.

357. Piers and Abutments.—In a series of equal arches the pier between two consecutive arches bears simply the weight of the two adjacent semi-arches, plus the load im-

* If the earth-filling is shallow, the laminæ directly under the track probably receive a greater pressure than the others.

mediately above the pier, and \therefore does not need to be as large as the abutment of the first and last arches, since these latter must be prepared to resist the oblique thrusts of their arches without help from the thrust of another on the other side.

In a very long series of arches it is sometimes customary to make a few of the intermediate piers large enough to act as abutments. These are called "abutment piers," and in case one arch should fall, no others would be lost except those occurring between the same two abutment piers as the first. See Fig. 392. *A* is an abutment-pier.



FIG. 392.

GRAPHICAL TREATMENT OF ARCH.

358.—Having found the "reduced load-contour," as in preceding paragraphs, for a given arch and load, we are ready to proceed with the graphic treatment, i.e., the first given, or assumed, form and thickness of arch-ring is to be investigated with regard to stability. It may be necessary to treat, separately, a lamina under the spandrel wall, and one under the interior loading. The constructions are equally well adapted to arches of all shapes, to Gothic as well as circular and elliptical.

359.—Case I. Symmetrical Arch and Symmetrical Loading.—(The "steady" (permanent) or "dead" load on an arch is usually symmetrical). Fig. 393. From symmetry we need

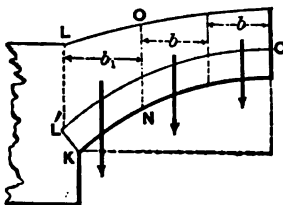

FIG. 393.

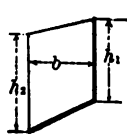

FIG. 394.

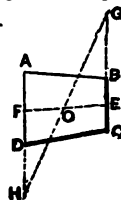

FIG. 395.

deal with only one half (say the left) of the arch and load. Divide this semi-arch and load into six or ten divisions by vertical lines; these divisions are *considered as trapezoids* and should have the same horizontal width = b (a convenient whole number of feet) except the last one, LKN , next the abutment, and this is a pentagon of a different width b_1 , (the remnant of the horizontal distance LC). The weight of masonry in each division is equal to (the area of division) \times (unity thickness of lamina) \times (weight of a cubic unit of arch-ring). For example for a division having an area of 20 sq. feet, and composed of masonry weighing 160 lbs. per cubic foot, we have $20 \times 1 \times 160 = 3,200$ lbs., applied through the centre of gravity of the division. The area of a trapezoid, Fig. 394, is $\frac{1}{2}b(h_1+h_2)$, and its centre of gravity may be found, Fig. 395, by the construction of Prob. 6, in § 26; or by § 27a. The weight of the pentagon LN , Fig. 393, and its line of application (through centre of gravity) may be found by combining results for the two trapezoids into which it is divided by a vertical through K . See § 21.

Since the weights of the respective trapezoids (*excepting* LN) are proportional to their middle vertical intercepts [such as $\frac{1}{2}(h_1+h_2)$ Fig. 394] these intercepts (transferred with the dividers) may be used directly to form the load-line, Fig. 396, or proportional parts of them if more convenient. The force scale, which this implies, is easily computed, and a proper length calculated to represent the weight of the odd division LN ; i.e., 1 . . . 2 on the load-line.

Now consider A , the middle point of the abutment joint, Fig. 396, as the starting point of an equilibrium polygon (or abutment of a linear arch) for a given loading, and require that this equilibrium polygon shall pass through p , the middle of the crown joint, and through the middle of the abutment joint on the right (not shown in figure).

Proceed as in § 342, thus determining the polygon Ap for the half-arch. Draw joints in the arch-ring through those points where the extrados is intersected by the ver-

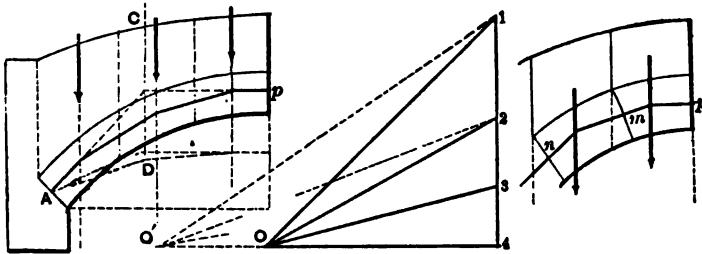

FIG. 396.

FIG. 397.

tical separating the divisions (not the gravity verticals). The points in which these joints are cut by the segments of the equilibrium polygon, Fig. 397, are (very nearly, if the joint is not more than 60° from p , the crown) the points of application in these joints, respectively, of the resultant pressures on them, (if this is the "true linear arch" for this arch and load) while the amount and direction of each such pressure is given by the proper ray in the force-diagram.

If at any joint so drawn the linear arch (or equilibrium polygon) passes outside the middle third of the arch-ring, the point A , or p , (or both) should be judiciously moved (within the middle third) to find if possible a linear arch which keeps within limits at all joints. If this is found impossible, the thickness of the arch-ring may be increased at the abutment (giving a smaller increase toward the crown) and the desired result obtained; or a change in the distribution or amount of the loading, if allowable, may gain this object. If but one linear arch can be drawn within the middle third, it may be considered the "true" one; if several, the one most nearly co-inciding with the middles of the joints (see §§ 351 and 352) is so considered.

360.—Case II. Unsymmetrical Loading on a Symmetrical Arch; (e.g., arch with live load covering one half-span as in Figs. 390 and 391). Here we must evidently use a full force diagram, and the full elevation of the arch-ring and load.

See Fig. 398. Select three points A , p , and B , as follows, to determine a *trial equilibrium polygon*:

Select A at the *lower limit* of the middle third of the

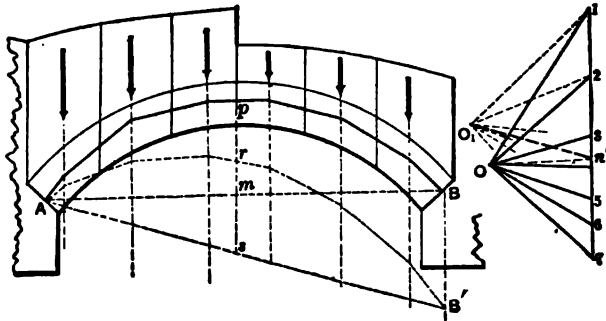

FIG. 398.

abutment-joint at the end of the span which is the more heavily-loaded; in the other abutment-joint take B at the upper limit of the middle third; and take p in the middle of the crown-joint. Then by § 341 draw an equilibrium polygon (i.e., a linear arch) through these three points for the given set of loads, and if it does not remain within the middle third, try other positions for A , p , and B , within the middle third. As to the "true linear arch" alterations of the design, etc., the same remarks apply as already given in Case I. Very frequently it is not necessary to draw more than one linear arch, for a given loading, for even if one could be drawn nearer the middle of the arching than the first, that fact is most always apparent on mere inspection, and the one already drawn (if within middle third) will furnish values sufficiently accurate for the pressures on the respective joints, and their direction angles.

360a.—The design for the arch-ring and loading is not to be considered satisfactory until it is ascertained that for the dead load and any possible combination of live-load (in addition) the pressure at any joint is

- (1.) Within the middle third of that joint;
- (2.) At an angle of $< 30^\circ$ with the normal to joint-surface.
- (3.) Of a *mean* pressure per square inch not $>$ than $\frac{1}{20}$ of the ultimate crushing resistance. (See § 348.)

§ 361. **Abutments.**—The abutment should be compactly and solidly built, and is then treated as a single rigid mass. The pressure of the lowest voussoir upon it (considering a lamina one foot thick) is given by the proper ray of the force diagram ($O \dots 1$, e. g., in Fig. 396) in amount and direction. The stability of the abutment will depend on the amount and direction of the resultant obtained by combining that pressure P_a with the weight G of the abutment and its load, see Fig. 399. Assume a probable width RS

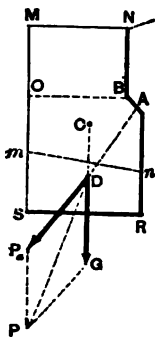

FIG. 399.

for the abutment and compute the weight G of the corresponding abutment $OBRS$ and $MNBO$, and find the centre of gravity of the whole mass C . Apply G in the vertical through C , and combine it with P_a at their intersection D . The resultant P should not cut the base RS in a point beyond the middle third (or, if this rule gives too massive a pier, take such a width that the pressure per square inch at S shall not exceed a safe value as computed from § 362.) After one or two trials a satisfactory width can be obtained.

We should also be assured that the angle PDG is less than 30° . The horizontal joints above RS should also be tested as if each were, in turn, the lowest base, and if necessary may be inclined (like mn) to prevent slipping. On no joint should the maximum pressure per square inch be $>$ than $\frac{1}{10}$ the crushing strength of the cement. Abutments of firm natural rock are of course to be preferred where they can be had. If water penetrates under an abutment its buoyant effort lessens the weight of the latter to a considerable extent.

362. Maximum Pressure Per Unit of Area When the Resultant Pressure Falls at Any Given Distance from the Middle; according to Navier's theory of the distribution of the pressure; see § 346. Case I. Let the resultant pressure P , Fig. 400, (a),

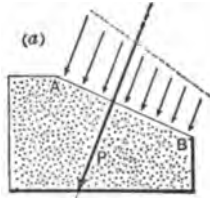

FIG. 400.

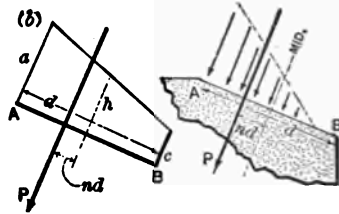

FIG. 401.

fall within the middle third, a distance = nd ($< \frac{1}{6} d$) from the middle of joint ($d =$ depth of joint.) Then we have the following relations :

p (the mean press. per. sq. in.), p_m (max. press. per sq. in.), and p_n (least press. per sq. in.) are proportional to the lines h (mid. width), a (max. base), and c (min. base) respectively, of a trapezoid, Fig. 400, (b), through whose centre of gravity P acts. But (§ 26)

$$nd = \frac{d}{6} \frac{a-c}{a+c} \text{ i.e., } n = \frac{1}{6} \frac{a-h}{h} \text{ or } a = h(6n+1)$$

$\therefore p_m = p(6n+1)$. Hence the following table :

If $nd = \frac{1}{6} d \mid \frac{1}{9} d \mid \frac{1}{18} d \mid$ then the max.
press. $p_m = 2 \mid \frac{5}{3} \mid \frac{4}{3} \mid$ times the mean pressure.

Case II. Let P fall outside the mid. third, a distance = nd ($> \frac{1}{6} d$) from the middle of joint. Here, since the joint is not considered capable of withstanding tension, we have a triangle, instead of a trapezoid. Fig. 401. First compute the mean press. per sq. in.

$$p = \frac{P \text{ (lbs.)}}{(1-2n) 18 d \text{ inches}} \text{ or from this table: (lamina one foot thick).}$$

For $nd =$	$\frac{4}{18} d$	$\frac{5}{18} d$	$\frac{6}{18} d$	$\frac{7}{18} d$	$\frac{8}{18} d$	$\frac{9}{18} d$
$p =$	$\frac{1}{10} \cdot \frac{P}{d}$	$\frac{1}{8} \cdot \frac{P}{d}$	$\frac{1}{6} \cdot \frac{P}{d}$	$\frac{1}{4} \cdot \frac{P}{d}$	$\frac{1}{2} \cdot \frac{P}{d}$	infinity.

(d in inches and P in lbs.; with arch lamina 1 ft. in thickness.)

Then the maximum pressure (at A , Fig. 401) $p_m = 2p$, becomes known, in lbs. per sq. in.

362a. Arch-ring under Non-vertical Forces.—An example of this occurs when a vertical arch-ring is to support the pressure of a liquid on its extrados. Since water-pressures are always at right angles to the surface pressed on, these pressures on the extradosal surface of the arch-ring form a system of non-parallel forces which are normal to the curve of the extrados at their respective points of application and lie in parallel vertical planes, parallel to the faces of the lamina. We here assume that the extradosal surface is a cylinder (in the most general sense) whose rectilinear elements are \perp to the faces of the lamina. If, then, we divide the length of the extrados, from crown to each abutment, into from six to ten parts, the respective pressures on the corresponding surfaces are obtained by multiplying the area of each by the depth of its centre of gravity from the upper free surface of the liquid, and this product by the weight of a unit of volume of the liquid; and each such pressure may be considered as acting through the centre of the area. Finally, if we find the resultant of each of these pressures and the weight of the corresponding portion of the arch-ring, these resultants form a series of non-vertical forces in a plane, for which an equilibrium polygon can then be passed through three assumed points by § 378a, these three points being taken in the crown-joint and the two abutment-joints. As to the "true linear arch" see § 359.

As an extreme theoretic limit it is worth noting that if the extrados and intrados of the arch-ring are concentric circles; if the weights of the voussoirs are neglected; and if the rise of the arch is very small compared with the depth of the crown below the water surface, then the *circular-centre-line of the arch-ring is the "true linear arch."*

CHAPTER XI

ARCH-RIBS.

364. Definitions and Assumptions.—An arch-rib (or *elastic-arch*, as distinguished from a block-work arch) is a rigid curved beam, either solid, or built up of pieces like a truss (and then called a braced arch) the stresses in which, under a given loading and with prescribed mode of support it is here proposed to determine. The rib is supposed symmetrical about a vertical plane containing its axis or middle line, and the Moment of Inertia of any cross section is understood to be referred to a gravity axis of the section, which (the axis) is perpendicular to the said vertical plane. It is assumed that in its strained condition under a load, the shape of the rib differs so little from its form when unstrained that the change in the abscissa or ordinate of any point in the rib axis (a curve) may be neglected when added (algebraically) to the coordinate itself; also that the dimensions of a cross-section are small compared with the radius of curvature at any part of the curved axis, and with the span.

365. Mode of Support.—Either extremity of the rib may be *hinged* to its pier (which gives freedom to the end-tangent-line to turn in the vertical plane of the rib when a load is applied); or may be *fixed*, i.e., so built-in, or bolted rigidly to the pier, that the end-tangent-line is incapable of changing its direction when a load is applied. A hinge may be inserted anywhere along the rib, and of course

destroys the rigidity, or resistance to bending at that point. (A hinge having its pin horizontal \perp to the axis of the rib is meant). Evidently no more than three such hinges could be introduced along an arch-rib between two piers; unless it is to be a *hanging* structure, acting as a suspension-cable.

366. Arch Rib as a Free Body.—In considering the whole rib free it is convenient, for graphical treatment, that no section be conceived made at its extremities, if fixed; hence in dealing with that mode of support the end of the rib will be considered as having a rigid prolongation reaching to a point vertically above or below the pier junction, and there acted on by a force of such unknown amount and direction as to preserve the actual extremity of the rib and its tangent line in the same position and direction as they really are. As an illustration of this Fig. 402

shows *free* an arch rib. ONB , with its extremities O and B fixed in the piers, with no hinges, and bearing two loads P_1 and P_2 . The other forces of the system holding it in equilibrium

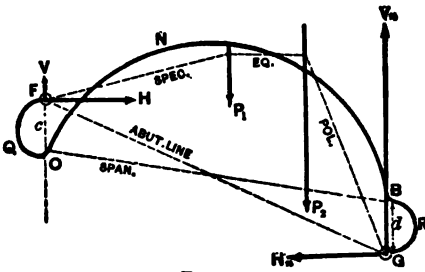

FIG. 402.

are the horizontal and vertical components, of the pier reactions (H , V , H_n , and V_n), and in this case of fixed ends each of these two reactions is a single force not intersecting the end of the rib, but cutting the vertical through the end in some point F (on the left; and in G on the right) at some vertical distance c , (or d), from the end. Hence the utility of these imaginary prolongations OQF , and BRG , the pier being supposed removed. Compare Figs. 348 and 350.

The imaginary points, or hinges, F and G , will be called *abutments* being such for the special equilibrium polygon

(dotted line), while O and B are the real ends of the curved beam, or rib.

In this system of forces there are five unknowns, viz: V , V_n , $H = H_n$, and the distances c and d . Their determination by analysis, even if the rib is a circular arc, is extremely intricate and tedious; but by graphical statics (Prof. Eddy's method; see § 350 for reference), it is comparatively simple and direct and applies to *any shape* of rib, and is sufficiently accurate for practical purposes. This method consists of constructions leading to the location of the "special equilibrium polygon" and its force diagram. In case the rib is hinged to the piers, the reactions of the latter act through these hinges, Fig. 403,

i. e., the abutments of the special equilibrium polygon coincide with the ends of the rib O and B , and for a given rib and load the unknown quantities are only three V , V_n , and H ; (strictly there are four; but $\sum X = 0$ gives $H_n = H$). The solution

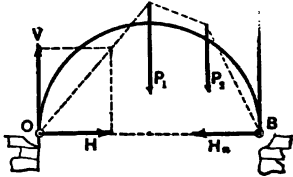

FIG. 403.

by analytics is possible only for ribs of simple algebraic curves and is long and cumbrous; whereas Prof. Eddy's graphic method is comparatively brief and simple and is applicable to any shape of rib whatever.

367. Utility of the Special Equilibrium Polygon and its force diagram. The use of locating these will now be illustrated [See § 332]. As proved in §§ 332 and 334 the compression in each "rod" or segment of the "special equilibrium polygon" is the anti-stress resultant of the cross sections in the corresponding portion of the beam, rib, or other structure, the value of this compression (in lbs. or tons) being measured by the length of the parallel ray in the force diagram. Suppose that in some way (to be explained subsequently) the special equilibrium polygon and its force diagram have been drawn for the arch-rib in Fig. 404 having fixed ends, O and B , and no hinges; required the elastic stresses in any cross-section of the rib as at m . Let the

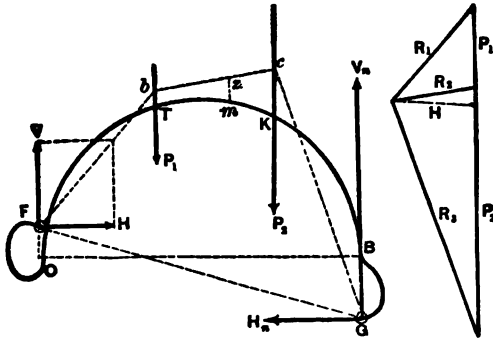

FIG. 404.

scale of the force-diagram on the right be 200 lbs. to the inch, say, and that of the space-diagram (on the left) 30 ft. to the inch.

The cross section m lies in a portion TK , of the rib, corresponding to the rod or segment bc of the equilibrium polygon; hence its anti-stress-resultant is a force R_2 acting in the line bc , and of an amount given in the force-diagram. Now R_2 is the resultant of V , H , and P_1 , which with the elastic forces at m form a system in equilibrium, shown in Fig. 405; the portion $FOTm$ being considered free. Hence

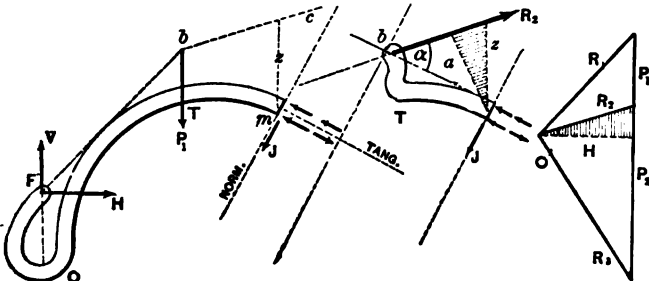

FIG. 405.

FIG. 406.

taking the tangent line and the normal at m as axes we should have Σ (tang. comps.) = 0; Σ (norm. comps.) = 0; and Σ (moms. about gravity axis of the section at m) = 0, and could thus find the unknowns p_1 , p_2 , and J , which appear in the expressions $p_1 F$ the thrust, $\frac{p_2 I}{e}$ the moment of

the stress-couple, and J the shear. These elastic stresses are classified as in § 295, which see. p_1 and p_2 are *lbs. per square inch*, J is *lbs.*, e is the distance from the horizontal gravity axis of the section to the outermost element of area, (where the compression or tension is p_2 lbs. per sq. in., as due to the stress-couple alone) while I is the "moment of inertia" of the section about that gravity axis. [See §§ 247 and 295; also § 85]. Graphics, however, gives us a more direct method, as follows: Since R_2 , in the line bc , is the equivalent of V , H , and P_1 , the stresses at m will be just the same as if R_2 acted directly upon a lateral prolongation of the rib at T (to intersect bc Fig. 405) as shown in Fig. 406, this prolongation Tb taking the place of TOF in Fig. 405. The force diagram is also reproduced here. Let a denote the length of the \perp from m 's gravity axis upon bc , and z the vertical intercept between m and bc . For this imaginary free body, we have,

$$\text{from } \Sigma (\text{tang. comps.})=0, R_2 \cos a=p_1 F$$

$$\text{and from } \Sigma (\text{norm. comps.})=0, R_2 \sin a=J$$

$$\left. \begin{array}{l} \text{while from } \Sigma (\text{moms. about}) \\ \text{the gravity axis of } m)=0, \end{array} \right\} \text{ we have } R_2 a = \frac{p_2 I}{e}.$$

But from the two similar triangles (shaded; one of them is in force diagram) $a : z :: H : R_2$, $\therefore R_2 a = Hz$, whence we may rewrite these relations as follows (with a general statement), viz.:

If the Special Equilibrium Polygon and Its Force Diagram Have Been Drawn for a given arch-rib, of given mode of support, and under a given loading, then in any cross-section of the rib, we have (F = area of section):

$$(1) \quad \text{The Thrust, i.e., } p_1 F = \left\{ \begin{array}{l} \text{The projection of the } \textit{proper} \\ \textit{ray} \text{ (of the force diagram) up-} \\ \text{on the } \textit{tangent line} \text{ of the rib} \\ \text{drawn at the given section.} \end{array} \right.$$

- (2.) The Shear, i.e., J , = $\left\{ \begin{array}{l} \text{The projection of the proper} \\ \text{ray (of the force diagram) up-} \\ \text{on the normal to the rib curve} \\ \text{at the given section.} \end{array} \right.$
 (upon which dependsthe shearing stress in the web). (See §§ 253 and 256).
- (3.) The Moment of the stress couple, i.e., $\frac{P_2 I}{e}$, = $\left\{ \begin{array}{l} \text{The product (} Hx \text{) of the } H \\ \text{(or pole-distance) of the force-} \\ \text{diagram by the vertical dis-} \\ \text{tance of the gravity axis of the} \\ \text{section from the spec. equilib-} \\ \text{rium polygon.} \end{array} \right.$

By the "proper ray" is meant that ray which is parallel to the segment (of the equil. polygon) immediately under or above which the given section is situated. Thus in Fig. 404, the proper ray for any section on TK is B_1 ; on KB , B_2 ; on TO , B_3 . The *projection* of a ray upon any given tangent or normal, is easily found by drawing through each end of the ray a line \perp to the tangent (or normal); the length between these \perp 's on the tangent (or normal) is the force required (by the scale of the force diagram). We may thus construct a shear diagram, and a thrust diagram for a given case, while the successive vertical intercepts between the rib and special equilibrium polygon form a moment diagram. For example of the z of a point m is $\frac{1}{2}$ inch in a space diagram drawn to a scale of 20 feet to the inch, while H measures 2.1 inches in a force diagram constructed on a scale of ten tons to the inch, we have, for the moment of the stress-couple at m , $M = Hx = [2.1 \times 10]$ tons $\times [\frac{1}{2} \times 20]$ ft. = 210 ft. tons.

368.—It is thus seen how a location of the special equilibrium polygon, and the lines of the corresponding force-diagram, lead directly to a knowledge of the stresses in all the cross-sections of the curved beam under consideration, bearing a given load; or, vice versâ, leads to a statement of conditions to be satisfied by the dimensions of the rib, for proper security.

It is here supposed that the rib has sufficient lateral

bracing (with others which lie parallel with it) to prevent buckling sideways in any part like a long column. Before proceeding to the complete graphical analysis of the different cases of arch-ribs, it will be necessary to devote the next few paragraphs to developing a few analytical relations in the theory of flexure of a curved beam, and to giving some processes in "graphical arithmetic."

369. Change in the Angle Between Two Consecutive Rib Tangents when the rib is loaded, as compared with its value before loading. Consider any small portion (of an arch rib) included between two consecutive cross-sections; Fig. 407. $KHGW$ is its unstrained form. Let EA , $= ds$, be the original length of this portion of the rib axis. The length of all the fibres (\parallel to rib-axis) was originally $= ds$ (nearly) and the two consecutive tangent-lines, at E and A , made an angle $= d\theta$ originally, with each other. While under strain, however, all the fibres are shortened *equally* an amount $d\lambda_1$, by the uniformly distributed tangential thrust, but are *unequally* shortened (or lengthened, according as they are on one side or the other of the gravity axis E , or A , of the section) by the system of forces making what we call the "stress couple," among which the stress at the distance e from the gravity axis A of the section is called p , per square inch; so that the tangent line at A' now takes the direction $A'D$ ∇ to $H'A'G'$ instead of $A'C$ (we suppose the section at E to remain fixed, for conveni-

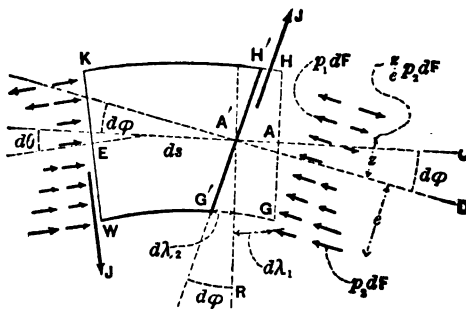

FIG. 407.

the other. When the rib is unstrained (as it is supposed to be, on the left, its own weight being neglected; it is not supposed sprung into place, but is entirely without strain) then the angle between the end-tangents has some value $\theta' = \int_0^B d\theta =$ the sum of the successive small angles $d\theta$ for each element ds of the rib curve (or axis). After loading, [on the right, Fig. 408], this angle has increased having now a value

$$\theta' + \int_0^B d\varphi, \text{ i.e., a value } = \theta' + \int_0^B \frac{Mds}{EI} \quad \dots \quad (I)$$

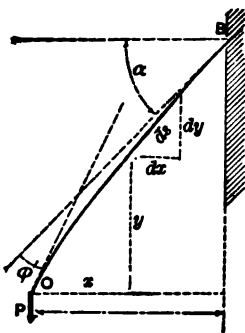

FIG. 409.

There must be no hinge between O and B .

§ 371. Example of Equation (I) in Analysis.—A straight, homogeneous, prismatic beam, Fig. 409, its own weight neglected, is fixed obliquely in a wall. After placing a load P on the free end, required the angle between the end-tangents. This was zero before loading \therefore its value after loading is

$$= 0 + \varphi' = 0 + \frac{1}{EI} \int_0^B Mds$$

By considering free a portion between O and any ds of the beam, we find that $M = Px =$ mom. of the stress couple. The flexure is so slight that the angle between any ds and its dx is still practically $= \alpha$ (§ 364), and $\therefore ds = dx \sec \alpha$. Hence, by substitution in eq. (I.) we have

$$\varphi' = \frac{1}{EI} \int_0^B Mds = \frac{P \sec \alpha}{EI} \int_0^l x dx = \frac{P \sec \alpha}{EI} \left[\frac{x^2}{2} \right]_0^l;$$

$$\therefore \varphi' = \frac{P(\cos \alpha)l^2}{2EI} \quad [\text{Compare with § 237}].$$

It is now apparent that if *both* ends of an arch rib are *fixed*, when unstrained, and the rib be then loaded (within elastic limit, and deformation slight) we must have

$$\int_0^B (Mds + EI) = \text{zero, since } \varphi' = 0.$$

372. Projections of the Displacement of any Point of a Loaded Rib Relatively to Another Point and the Tangent Line at the Latter.—(There must be no hinge between *O* and *B*). Let *O* be the point whose displacement is considered and *B* the other point. Fig. 410. If *B*'s tangent-line is fixed while the extremity *O* is not supported in any way (Fig. 410) then a load *P* put on, *O* is displaced to a new position *O*_n.

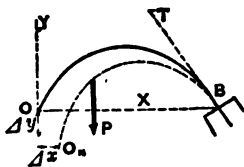

FIG. 410.

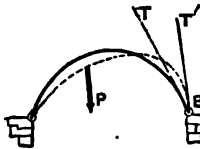

FIG. 411.

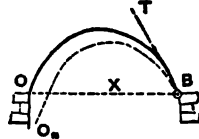

FIG. 412.

With *O* as an origin and *OB* as the axis of *X*, the *projection* of the displacement *OO*_n upon *X*, will be called *Δx*, that upon *Y*, *Δy*.

In the case in Fig. 410, *O*'s displacement with respect to *B* and its tangent-line *BT*, is also its *absolute displacement in space*, since neither *B* nor *BT* has moved as the rib changes form under the load. In Fig. 411, however, the extremities *O* and *B* are both hinged to piers, or supports, the dotted line showing its form when deformed under a load. The hinges are supposed immovable, the rib being free to turn about them without friction. The dotted line is the changed form under a load, and the *absolute displacement* of *O* is zero; but not so its displacement relatively to *B* and *B*'s tangent *BT*, for *BT* has moved to a new position *BT'*. To find this relative displacement conceive the new curve of the rib superposed on the old in a way that *B* and *BT* may coincide with their original po-

sitions, Fig. 412. It is now seen that O 's displacement relatively to B and BT is not zero but $=OO_n$, and has a small Δx but a comparatively large Δy . In fact for this case of hinged ends, *piers immovable*, rib continuous between them, and deformation slight, we shall write $\Delta x =$ zero as compared with Δy , the axis X passing through OB .

373. Values of the X and Y Projections of O 's Displacement Relatively to B and B 's Tangent; the origin being taken at O .

Fig. 413. Let the coordinates of the different points E, D, C , etc., of the rib, referred to O and an arbitrary X axis, be x and y , their radial distances from O being u (i.e., u for C , u' for D , etc.; in general, u). $OEDC$ is the unstrained form of the rib, (e.g., the form it

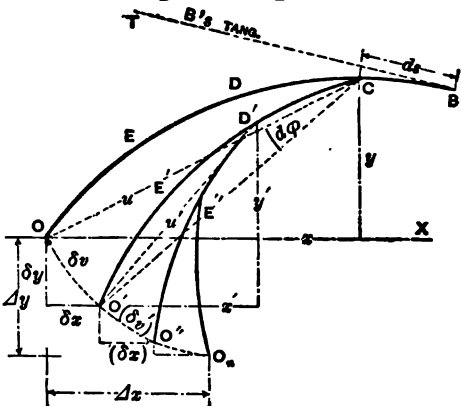

FIG. 413.

would assume if it lay flat on its side on a level platform, under no straining forces), while $O_nE'D'CB$ is its form under some loading, i.e., under strain. (The superposition above mentioned (§ 372) is supposed already made if necessary, so that BT is tangent at B to both forms). Now conceive the rib OB to pass into its strained condition by the successive bending of each ds in turn. The straining or bending of the first ds, BC , through the small angle $d\phi$ (dependent on the moment of the stress couple at C in the strained condition) causes the whole finite piece OC to turn about C as a centre through the same small angle $d\phi$; hence the point O describes a small linear arc $OO' = \delta v$, whose radius $= u$ the hypotenuse of the x and y of C , and whose value \therefore is $\delta v = u d\phi$.

Next let the section D , now at D' , turn through its proper angle $d\phi'$ (dependent on its stress-couple) carrying

with it the portion $D'O'$, into the position $D'O''$, making O' describe a linear arc $O'O''=(\delta v)'=u'd\phi'$, in which u' = the hypotenuse on the x' and y' (of D), (the deformation is so slight that the co-ordinates of the different points referred to O and X are not appreciably affected). Thus, each section having been allowed to turn through the angle proper to it, O finally reaches its position, O_n , of displacement. Each successive δv , or linear arc described by O , has a shorter radius. Let δx , $(\delta x)'$, etc., represent the projections of the successive (δv) 's upon the axis X ; and similarly δy , $(\delta y)'$ etc., upon the axis Y . Then the total X projection of the curved line $O \dots O_n$ will be

$$\Delta x = \int \delta x \text{ and similarly } \Delta y = \int \delta y \dots (1)$$

But $\delta v = u d\phi$, and from similar right-triangles, $\delta x : \delta v :: y : u$ and $\delta y : \delta v :: x : u \therefore \delta x = yd\phi$ and $\delta y = xd\phi$; whence, (see (1) and (2) of §369)

$$\Delta x = \int \delta x = \int yd\phi = \int_0^s \frac{Myds}{EI} \dots (II)$$

$$\text{and } \Delta y = \int \delta y = \int xd\phi = \int_0^s \frac{Mxds}{EI} \dots (III)$$

If the rib is homogeneous E is constant, and if it is of constant cross-section, all sections being similarly cut by the vertical plane of the rib's axis (i.e., if it is a "curved prism") I , the moment of inertia is also constant.

374. Recapitulation of Analytical Relations, for reference (Not applicable if there is a hinge between O and B)

$$\left. \begin{array}{l} \text{Total Change in Angle between} \\ \text{tangent-lines } O \text{ and } B \end{array} \right\} = \int_0^s \frac{Mds}{EI} \dots (I)$$

$$\left. \begin{array}{l} \text{The X-Projection of } O\text{'s Displacement} \\ \text{Relatively to } B \text{ and } B\text{'s tangent-} \\ \text{line; (the origin being at } O) \\ \text{and the axes } X \text{ and } Y \text{ } \updownarrow \text{ to} \\ \text{each other)} \end{array} \right\} = \int_0^s \frac{Myds}{EI} \dots (II)$$

The Y-Projection of O's Displacement, } = $\int_0^r \frac{Mx ds}{EI}$. . . (III.)
 etc., as above.

Here x and y are the co-ordinates of points in the rib-curve, ds an element of that curve, M the moment of the stress-couple in the corresponding section as induced by the loading, or constraint, of the rib.

(The results already derived for deflections, slopes, etc., for straight beams, could also be obtained from these formulae, I, II and III. In these formulae also it must be remembered that no account has been taken of the shortening of the rib-axis by the thrust, nor of the effect of a change of temperature.)

374a. **Résumé of the Properties of Equilibrium Polygons and their Force Diagrams, for Systems of Vertical Loads.**—See §§ 335 to 343. Given a system of loads or vertical forces, P_1, P_2

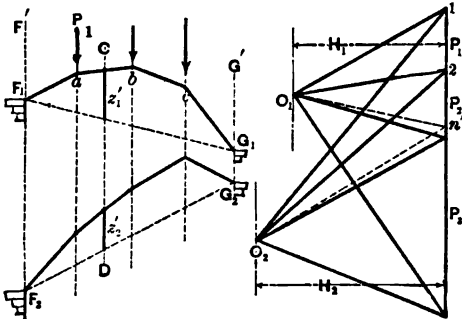

FIG. 414.

etc., Fig. 414, and two abutment verticals, F' and G' ; if we lay off, vertically, to form a "load-line," $1..2 = P_1, 2..3 = P_2$, etc., select any Pole, O_1 , and join $O_1 \dots 1, O_1 \dots 2$, etc.; also, beginning at any point F_1 in the vertical F' , if we draw $F_1 \dots a \parallel$ to $O_1 \dots 1$ to intersect the line of P_1 ; then $ab \parallel$ to $O_1 \dots 2$, and so on until finally a point G_1 , in G' , is determined; then the figure $F_1 abc G_1$ is an equilibrium polygon for the given loads and load verticals, and $O_1 \dots 1234$ is its "force diagram." The former is so called because the short segments $F_1 a, ab$, etc., if considered to be rigid and imponderable rods, in a vertical plane, hinged to each other and the terminal ones to abutments F_1 and G_1 , would be in equilibrium under the given loads hung at the joints. An infinite number of equilib-

rium polygons may be drawn for the given loads and abutment-verticals, by choosing different poles in the force diagram. [One other is shown in the figure; O_2 is its pole. ($F_1 G_1$ and $F_2 G_2$ are abutment lines.)] For all of these the following statements are true :

(1.) A line through the pole, \parallel to the abutment line cuts the load-line in the same point n' , whichever equilibrium polygon be used (\therefore any one will serve to determine n').

(2.) If a vertical CD be drawn, giving an intercept z' in each of the equilibrium polygons, the product $H z'$ is the same for all the equilibrium polygons. That is, (see Fig. 414) for any two of the polygons we have

$$H_1 : H_2 :: z'_1 : z'_2 ; \text{ or } H_2 z'_2 = H_1 z'_1.$$

(3.) The compression in each rod is given by that "ray" (in the force diagram) to which it is parallel.

(4.) The "pole distance" H , or \perp let fall from the pole upon the load-line, divides it into two parts which are the vertical components of the compressions in the abutment-rods *respectively* (the other component being horizontal); H is the horizontal component of each (and, in fact, of each of the compressions in all the other rods). The compressions in the extreme rods may also be called the abutment reactions (oblique) and are given by the extreme rays.

(5.) Three Points [not all in the same segment (or rod)] determine an equilibrium polygon for given loads. Having given, then, three points, we may draw the equilibrium polygon by §341.

375. Summation of Products. Before proceeding to treat graphically any case of arch-ribs, a few processes in graphical arithmetic, as it may be called, must be presented, and thus established for future use.

To make a summation of products of two factors in each by means of an equilibrium polygon.

Construction. Suppose it required to make the summation $\Sigma (xz)$ *i. e.*, to sum the series

$$x_1 z_1 + x_2 z_2 + x_3 z_3 + \dots \text{ by graphics.}$$

Having first arranged the terms in the order of magnitude of the x 's, we proceed as follows: Supposing, for illustration, that two of the z 's (z_3 and z_4) are negative (dotted in figure) see Fig. 415. These quantities x and z may be of any nature whatever, anything capable of being represented by a length, laid off to scale.

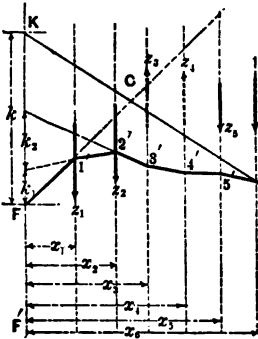

FIG. 415.

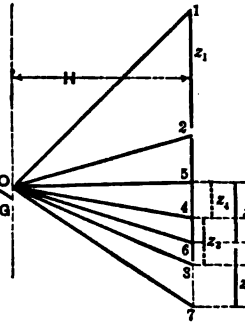

FIG. 416.

First, in Fig. 416, lay off the z 's in their order, end to end, on a vertical load-line taking care to lay off z_3 and z_4 upward in their turn.

Take any convenient pole

O ; draw the rays $O \dots 1, O \dots 2$, etc.; then, having previously drawn vertical lines whose horizontal distances from an extreme left-hand vertical F' are made $= x_1, x_2, x_3$, etc., respectively, we begin at any point F' , in the vertical F' , and draw a line \parallel to $O \dots 1$ to intersect the x_1 vertical in some point; then $1' 2' \parallel$ to $O \dots 2$, and so on, following carefully the proper order. Produce the last segment ($6' \dots G$ in this case) to intersect the vertical F' in some point K . Let $KF = k$ (measured on the same scale as the x 's), then the summation required is

$$\Sigma_1^6 (xz) = Hk.$$

H is measured on the scale of the z 's, which need not be the same as that of the x 's; in fact the z 's may not be the same kind of quantity as the x 's.

[PROOF.—From similar triangles $H : z_1 :: x_1 : k_1, \therefore x_1 z_1 = Hk_1$;
and “ “ “ “ $H : z_2 :: x_2 : k_2, \therefore x_2 z_2 = Hk_2$.

and so on. But $H(k_1+k_2+\text{etc.})=H \times \overline{FK}=Hk$.

376. Gravity Vertical.—From the same construction in Fig. 415 we can determine the line of action (or gravity vertical) of the resultant of the parallel vertical forces $z_1, z_2, \text{ etc.}$ (or loads); by prolonging the first and last segments

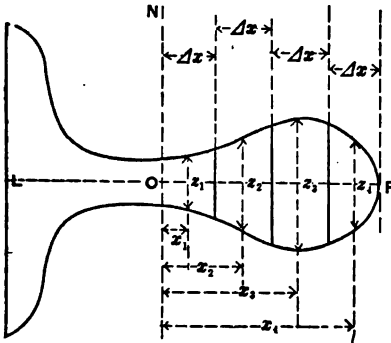

FIG. 416 a.

to their intersection at C . The resultant of the system of forces or loads acts through C and is vertical in this case; its value being $= \Sigma (z)$, that is, it = the length 1...7 in the force diagram, interpreted by the proper scale. It is now supposed that the z 's represent forces, the x 's being their respective lever arms about F . If the z 's represent the areas of small finite portions of a large plane figure, we may find a gravity-line (through C) of that figure by the above construction; each z, z being-applied through the centre of gravity of its own portion.

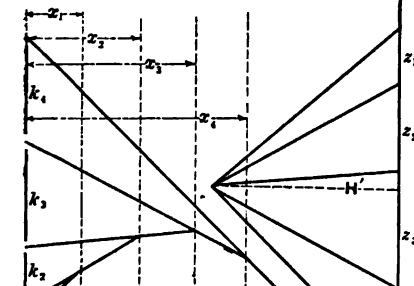

FIG. 416 b.

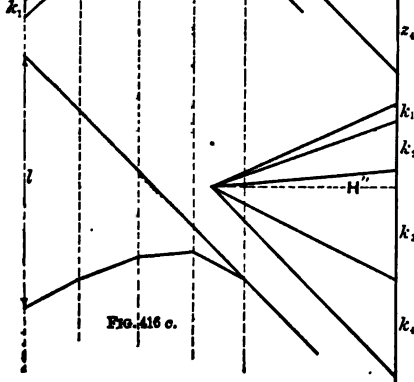

FIG. 416 c.

Calling the distance \bar{x} between the verticals through C and F , we have also $\bar{x} \cdot \Sigma (z) = \Sigma (xz)$ because $\Sigma (z)$ is the resultant of the $\parallel z$'s. This is also evident from the proportion (similar triangles)

$$H : (1 \dots 7) :: \bar{x} : k.$$

376 a. Moment of Inertia (of Plane Figure) by Graphica. — Fig. 416 a. $I_N = ?$ First, for the portion on right. Divide OR into equal parts each $= \Delta x$. Let z_1, z_2 , etc., be the middle ordinates of the strips thus obtained, and x_1 , etc. their abscissas (of middle points).

Then we have approximately

$$I_N \text{ for } OR = \Delta x \cdot z_1 x_1^2 + \Delta x \cdot z_2 x_2^2 + \dots \dots \dots \\ = \Delta x [(z_1 x_1) x_1 + (z_2 x_2) x_2 + \dots] \dots (1)$$

But by §375 we may construct the products $z_1 x_1, z_2 x_2$, etc., taking a convenient H' , (see Fig. 416, (b)), and obtain k_1, k_2 , etc., such that $z_1 x_1 = H' k_1, z_2 x_2 = H' k_2$, etc. Hence eq. (1) becomes:

$$I_N \text{ for } OR \text{ approx.} = H' \Delta x [k_1 x_1 + k_2 x_2 + \dots] \dots (2)$$

By a second use of § 375 (see Fig. 416 c) we construct l , such that $k_1 x_1 + k_2 x_2 + \dots = H'' l$ [H'' taken at convenience]. \therefore from eq. (2) we have finally, (approx.),

$$I_N \text{ for } OR = H' H'' l \Delta x \dots (3)$$

For example if $OR = 4$ in., with four strips, Δx would $= 1$ in.; and if $H' = 2$ in., $H'' = 2$ in., and $l = 5.2$ in., then

$$I_N \text{ for } OR = 2 \times 2 \times 5.2 \times 1.0 = 20.8 \text{ biquad. inches.}$$

The I_N for OL , on the left of N , is found in a similar manner and added to I_N for OR to obtain the total I_N . The position of a gravity axis is easily found by cutting the shape out of sheet metal and balancing on a knife edge; or may be obtained graphically by § 336; or 376.

377. Construction for locating a line vm (Fig. 417) at (a), in the polygon FG in such a position as to satisfy the two following conditions with reference to the vertical intercepts at 1, 2, 3, 4, and 5, between it and the given points 1, 2, 3, etc., of the perimeter of the polygon.

Condition I—(Calling these intercepts u_1, u_2 , etc., and their horizontal distances from a given vertical F, x_1, x_2 , etc.)

$\Sigma(u)$ is to = 0; i.e., the sum of the positive u 's must be numerically = that of the negative (which here are at 1 and 5). An infinite number of positions of vm will satisfy condition I.

Condition II— $\Sigma(ux)$ is to = 0; i.e., the sum of the

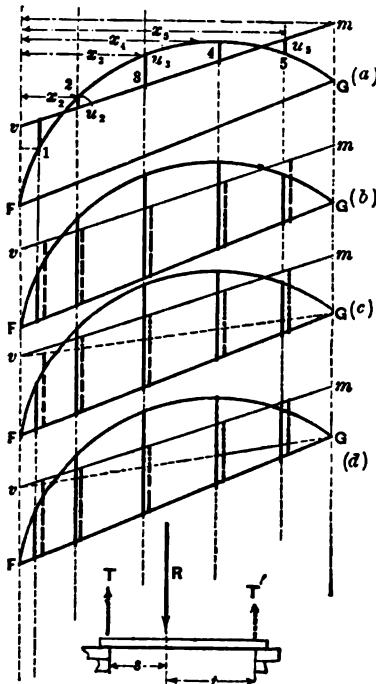

FIG. 417.

moments of the positive u 's about F must be that of the negative u 's. i.e., the moment of the resultant of the positive u 's must = that of the resultant of the negative; and \therefore (Condit. I being already satisfied) these two resultants must be *directly opposed* and *equal*. But the ordinates u in (a) are individually equal to the difference of the *full* and *dotted* ordinates in (b) with the same x 's \therefore the conditions may be rewritten :

I. Σ (full ords. in (b)) = Σ (dotted ords. in (b))

II. Σ [each full ord. in (b) \times its x] = Σ [each dotted ord. in (b) \times its x] i.e., the centres of gravity of the full

and of the dotted in (b) must lie in the *same vertical*.

Again, by joining vG , we may divide the dotted ordinates of (b) into two sets which are dotted, and broken, respectively, in (c) Then, finally, drawing in (d),

R , the resultant of full ords. of (c)
 T , " " " broken " "
 T' , " " " dotted " "

we are prepared to state in still another and final form the conditions which vm must fulfil, viz. :

(I.) $T + T'$ must = R ; and (II.) The resultant of T and T' must act in the same vertical as R .

In short, the quantities T , T' , and R must form a balanced system, considered as forces. All of which amounts practically to this: that if the verticals in which T and T' act are known and R be conceived as a load supported by a horizontal beam (see foot of Fig. 417, last figure) resting on piers in those verticals, then T and T' are the respective reactions of those piers. It will now be shown that the verticals of T and T' are easily found, being independent of the position of vm ; and that both the vertical and the magnitude of R , being likewise independent of vm , are determined with facility in advance. For, if v be shifted up or down, all the broken ordinates in (c) or (d) will change in the same proportion (viz. as vF changes), while the dotted ordinates, though shifted along their verticals, do not change in value; hence the shifting of v affects neither the vertical nor the value of T' , nor the vertical of T . The value of T , however, is proportional to vF . Similarly, if m be shifted, up or down, T' will vary proportionally to mG , but its vertical, or line of action, remains the same. T is unaffected in any way by the shifting of m . R , depending for its value and position on the full ordinates of (c) Fig. 417, is independent of the location of vm . We may \therefore proceed as follows :

1st. Determine R graphically, in amount and position, by means of § 376.

2ndly. Determine the verticals of T and T' by any trial position of vm (call it v_2m_2), and the corresponding trial values of T and T' (call them T_2 and T'_2).

3rdly. By the fiction of the horizontal beam, construct (§ 329) or compute the true values of T and T' , and then determine the true distances vF and mG by the proportions

$$vF : v_2F' :: T : T_2 \text{ and } mG : m_2G :: T' : T'_2.$$

Example of this. Fig. 418. (See Fig. 417 for s and t .)

From A toward B in (e) Fig. 418, lay off the lengths (or lines proportional to them) of the full ordinates 1, 2, etc., of (f). Take any pole O_1 , and draw the equilibrium polygon (f') and prolong its extreme segments to find C and thus determine R 's vertical. R is represented by AB . In (g) [same as (f) but shifted to avoid complexity of lines] draw a trial v_2m_2 and join v_2G_2 . Determine the sum T_2 of the broken ordinates (between v_2G_2 and F_2G_2) and its vertical line of application, precisely as in dealing with R ; also T''_2 that of the dotted ordinates (five) and its vertical. Now the true $T = Rt \div (s+t)$ and the true $T' = Rs \div (s+t)$. Hence compute $\overline{vF} = (T \div T_2) \overline{v_2F_2}$ and $\overline{mG} = (T' \div T''_2) \overline{m_2G_2}$, and by laying them off vertically upward from F and G respectively we determine v and m , i.e., the line vm to fulfil the conditions imposed at the beginning of this article, relating to the vertical ordinates intercepted between vm and given points on the perimeter of a polygon or curve.

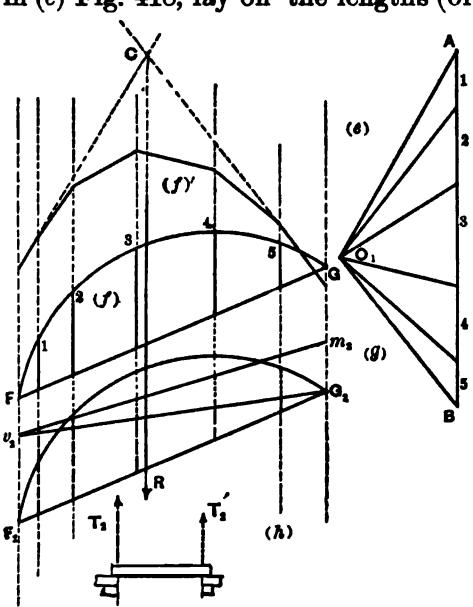

FIG. 418.

(between v_2G_2 and F_2G_2) and its vertical line of application, precisely as in dealing with R ; also T''_2 that of the dotted ordinates (five) and its vertical. Now the true $T = Rt \div (s+t)$ and the true $T' = Rs \div (s+t)$. Hence compute $\overline{vF} = (T \div T_2) \overline{v_2F_2}$ and $\overline{mG} = (T' \div T''_2) \overline{m_2G_2}$, and by laying them off vertically upward from F and G respectively we determine v and m , i.e., the line vm to fulfil the conditions imposed at the beginning of this article, relating to the vertical ordinates intercepted between vm and given points on the perimeter of a polygon or curve.

Note (a). If the verticals in which the intercepts lie are equidistant and quite numerous, then the lines of action of T_2 and T''_2 will divide the horizontal distance between F and G into three equal parts. This will be *exactly true* in the application of this construction to § 390.

Note (b). Also, if the verticals are symmetrically placed about a vertical line, (as will usually be the case) v_2m_2 is

best drawn parallel to FG , for then T_1 and T'_1 will be equal and equi-distant from said vertical line.

378. Classification of Arch-Ribs, or Elastic Arches, according to continuity and modes of support. In the accompanying figures the *full* curves show the *unstrained* form of the rib (before any load, even its own weight, is permitted to come upon it); the dotted curve shows its shape (much exaggerated) when bearing a load. For a given loading **Three Conditions** must be given to determine the special equilibrium polygon (§§ 366 and 367).

Class A.—Continuous rib, free to slip laterally on the piers, which have smooth horizontal surfaces, Fig. 420.

This is chiefly of theoretic interest, its consideration being therefore omitted. The pier reactions are necessarily vertical, just as if it were a straight horizontal beam.

Class B. Rib of Three Hinges, two at the piers and one intermediate (usually at the crown) Fig. 421. Fig. 36 also is an example of this. That is, the rib is discontinuous and of two segments. Since at each hinge the moment of the stress couple must be zero, the special equilibrium polygon must pass through the hinges. Hence as three points fully determine an equilibrium polygon for given load, the special equilibrium is drawn by § 341.

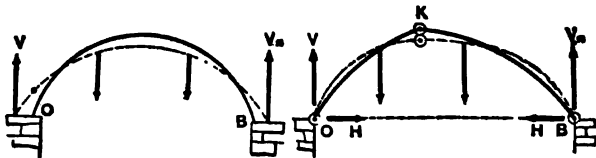

FIG. 420.

FIG. 421.

[§ 378a will contain a construction for arch-ribs of three hinges, when the forces are not all vertical.]

Class C. Rib of Two Hinges, these being at the piers, the rib continuous between. The piers are considered immovable, i.e., the span cannot change as a consequence of loading. It is also considered that the rib is fitted to its

hinges at a definite temperature, and is then under no constraint from the piers (as if it lay flat on the ground), not even its own weight being permitted to act when it is finally put into position. When the "false works" or temporary supports are removed, stresses are induced in the rib both by its loading, including its own weight, and by a change of temperature. Stresses due to temperature may be ascertained separately and then combined with those due to the loading. [Classes A and B are not subject to temperature stresses.] Fig.

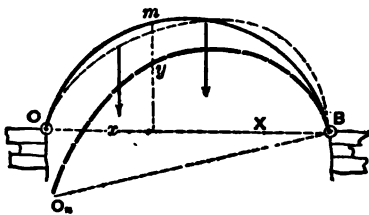

FIG. 422.

422 shows a rib of two hinges, at ends. Conceive the dotted curve (form and position under strain) to be superposed on the continuous curve (form before strain) in such a way that B and its tangent line (which has been displaced from its original position) may occupy their previous position. This gives us the broken curve O_nB . OO_n is \therefore O's displacement relatively to B and B's tangent. Now the piers being immovable O_nB (right line) = OB ; i.e., the X projection (or Δx) of OO_n upon OB (taken as an axis of X) is zero compared with its Δy . Hence as one condition to fix the special equilibrium polygon for a given loading we have (from § 373)

$$\int_0^B [Myds + EI] = 0 \quad . \quad . \quad . \quad (1)$$

The other two are that the } must pass through O . (2)
 special equilibrium polygon } " " " B . (3)

Class D. Rib with Fixed Ends and no hinges, i.e., continuous. Piers immovable. The ends may be fixed by being inserted, or built, in the masonry, or by being fastened to large plates which are bolted to the piers. [The St. Louis Bridge and that at Coblenz over the Rhine are of this class.] Fig. 423. In this class there being no hinges we

have no point given in advance through which the special equilibrium polygon must pass. However, since O 's displacement relatively (and absolutely) to B and B 's tangent is zero, both Δx and Δy [see § 373] = zero. Also the tangent-lines both at O and B being fixed in direction, the angle between them is the same under loading, or change of temperature, as when the rib was first placed in position under no strain and at a definite temperature.

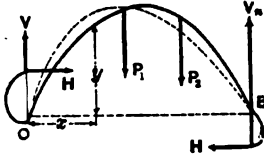

FIG. 423.

Hence the conditions for locating the special equilibrium polygon are

$$\int_0^B \frac{Mds}{EI} = 0; \int_0^B \frac{Myds}{EI} = 0; \int_0^B \frac{Mxds}{EI} = 0.$$

In the figure the imaginary rigid prolongations at the ends are shown [see § 366].

Other designs than those mentioned are practicable (such as: one end fixed, the other hinged; both ends fixed and one hinge between, etc.), but are of unusual occurrence.

378a. Rib of Three Hinges. Forces not all Vertical. If the given rib of three hinges upholds a roof, the wind-pressure on which is to be considered as well as the weights of the materials composing the roof-covering, the forces will not all be vertical. To draw the special equil. polygon in

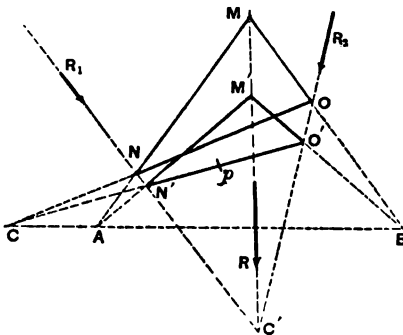

FIG. 423a.

such a case the following construction holds: Required to draw an equilibrium polygon, for any plane system of forces, through three arbitrary points, A , p and B ; Fig. 423a. Find the line of action of R_1 , the resultant of all the forces occurring between A and p ; also,

that of R_2 , the resultant of all forces between p and B ; also the line of action of R , the resultant of R_1 and R_2 , [see § 328.] Join any point M in R with A and also with B , and join the intersections N and O . Then AN will be the direction of the first segment, OB that of the last, and NO itself is the segment corresponding to p (in the desired polygon) of an equilibrium polygon for the given forces. See § 328. If $AN'pO'B$ are the corresponding segments (as yet unknown) of the desired equil. polygon, we note that the two triangles MNO and $M'N'O'$, having their vertices on three lines which meet in a point [i.e., R meets R_1 and R_2 in C'], are homological [see Prop. VII. of *Introduct. to Modern Geometry*, in *Chauvenet's Geometry*,] and that \therefore the three intersections of their corresponding sides must lie on the same straight line. Of those intersections we already have A and B , while the third must be at C , found at the intersection of AB and NO . Hence by connecting C and p , we determine N' and O' . Joining $N'A$ and $O'B$, the first ray of the required force diagram will be \parallel to $N'A$, while the last ray will be \parallel to $O'B$, and thus the pole of that diagram can easily be found and the corresponding equilibrium polygon, beginning at A , will pass through p and B .

(This general case includes those of §§ 341 and 342.)

379. Arch-Rib of two Hinges; by Prof. Eddy's Method.* [It is understood that the hinges are at the ends.] Required the location of the *special equilibrium polygon*. We here suppose the rib homogeneous (i.e., the modulus of Elasticity E is the same throughout), that it is a "curved prism" (i.e., that the moment of inertia I of the cross-section is constant), that the piers are on a level, and that the rib-curve is symmetrical about a vertical line. Fig.

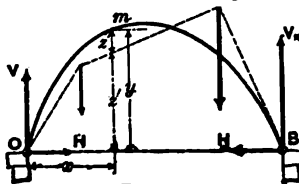

FIG. 424.

424. For each point m of the rib curve we have an x and y (both known, being the co-ordinates of the point), and also a z (intercept between rib and special equilibrium polygon) and a z' (intercept

* P. 25 of Prof. Eddy's book; see reference in preface of this work.

between the spec. eq. pol. and the axis X (which is OB).

The first condition given in § 378 for Class C may be transformed as follows, remembering [§ 367 eq. (3)] that $M = Hz$ at any point m of the rib (and that EI is constant).

$$\frac{1}{EI} \int_0^s My ds = 0, \text{ i.e., } \frac{H}{EI} \int_0^s zy ds = 0 \therefore \int_0^s zy ds = 0$$

$$\text{but } z = y - z' \} \therefore \int_0^s (y - z') y ds = 0; \text{ i.e., } \int_0^s yy ds = \int_0^s yz' ds \quad (1)$$

In practical graphics we can not deal with infinitesimals; hence we must substitute Δs a small finite portion of the rib-curve for ds ; eq. (1) now reads $\sum_0^B yy \Delta s = \sum_0^B yz' \Delta s$.

But if we take *all the Δs 's equal*, Δs is a common factor and cancels out, leaving as a final form for eq. (1)

$$\sum_0^B (yy) = \sum_0^B (yz') \quad . . . \quad (1)'$$

The other two conditions are that the special equilibrium polygon begins at O and ends at B . (The subdivision of the rib-curve into an *even* number of *equal* Δs 's will be observed in all problems henceforth.)

379a. Detail of the Construction. Given the arch-rib OB , Fig. 425, with specified loading. Divide the curve into

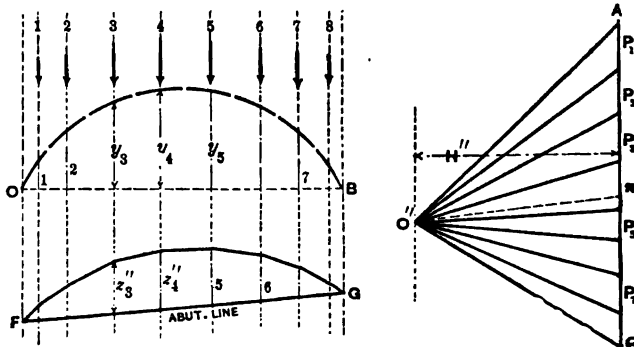

FIG. 425.

eight equal Δs 's and draw a vertical through the middle of each. Let the loads borne by the respective Δs 's be P_1, P_2 , etc., and with them form a vertical load-line AC to some convenient scale. With any convenient pole O'' draw a trial force diagram $O''AC$, and a corresponding trial equilibrium polygon FG , beginning at any point in the vertical F . Its ordinates z_1'', z_2'' , etc., are proportional to those of the special equil. pol. sought (whose abutment line is OB) [§ 374a (2)]. We next use it to determine n' [see § 374a]. We know that OB is the "abutment-line" of the required special polygon, and that \therefore its pole must lie on a horizontal through n' . It remains to determine its H , or pole distance, by equation (1)' just given, viz.: $\Sigma_1^8 yy = \Sigma_1^8 yz'$. First by § 375 find the value of the summation $\Sigma_1^8 (yy)$, which, from symmetry, we may write $= 2\Sigma_1^4 (yy) = 2[y_1y_1 + y_2y_2 + y_3y_3 + y_4y_4]$

Hence, Fig. 426, we obtain

$$\Sigma_1^8 (yy) = 2 [H_0 k]$$

Next, also by § 375, see Fig. 427, using the same pole distance H_0 , as in Fig. 426, we find

$$\Sigma_1^4 (yz'') = H_0 k_1''; \text{ i.e.,}$$

$$y_1 z_1'' + y_2 z_2'' + y_3 z_3'' + y_4 z_4'' = H_0 k_1''.$$

Again, since $\Sigma_3^8 (yz'') = y_8 z_8'' + y_7 z_7'' + y_6 z_6'' + y_5 z_5''$ which from symmetry (of rib)

$$= y_1 z_8'' + y_2 z_7'' + y_3 z_6'' + y_4 z_5'',$$

we obtain, Fig. 428,

$$\Sigma_3^8 (yz'') = H_0 k_r'', \text{ (same } H_0); \text{ and } \therefore$$

$$\Sigma_1^8 (yz'') = H_0 (k_1'' + k_r''). \text{ If now we find that } k_1'' + k_r'' = 2k,$$

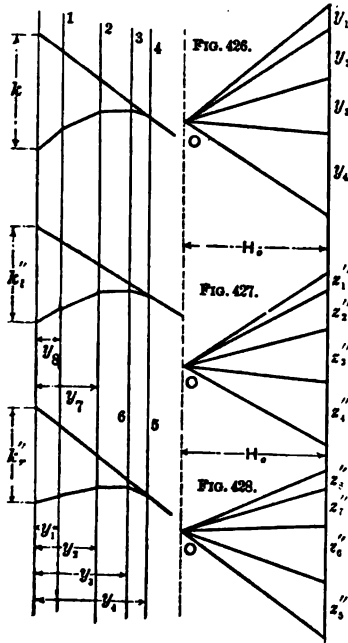

the condition $\Sigma_1^3 (yy) = \Sigma_1^3 (yz'')$ is satisfied, and the pole distance of our trial polygon in Fig. 425, is also that of the special polygon sought; i.e., the z'' 's are identical in value with the z 's of Fig. 424. In general, of course, we do not find that $k_1'' + k_r'' = 2k$. Hence the z'' 's must all be increased in the ratio $2k : (k_1'' + k_r'')$ to become equal to the z 's. That is, the pole distance H of the spec. equil. polygon must be

$$H = \frac{k_1'' + k_r''}{2k} H' \quad (\text{in which } H' = \text{the pole distance of the trial polygon}) \text{ since from §339 the ordi-}$$

nates of two equilibrium polygons (for the same loads) are inversely as their pole distances. Having thus found the H of the special polygon, knowing that the pole must lie on the horizontal through n' , Fig. 425, it is easily drawn, beginning at O . As a check, it should pass through B .

For its utility see § 367, but it is to be remembered that the stresses as thus found in the different parts of the rib under a given loading, must afterwards be combined with those resulting from change of temperature and the shortening of the rib axis due to the tangential thrusts, before the actual stress can be declared in any part.

[NOTE.—If the "moment of inertia," I , of the rib-section is different at different sections, i.e., if I is variable,

$$\text{for eq. (1)'} \text{ we may write } \Sigma_0^3 \left(y \cdot \frac{y}{n} \right) = \Sigma_0^3 \left(y \cdot \frac{z'}{n} \right) \dots (1)''$$

(where $n = \frac{I}{I_0}$, I_0 being the moment of inertia of a particular section taken as a standard and I that at any section of rib) and in Fig. 426, use the $\frac{y}{n}$ of each Δs instead of y in the vertical "load-line," and $\frac{z''}{n}$ for z'' in Figs. 427 and 428].

380. Arch Rib of Fixed Ends and no Hinges.—Example of Class D. Prof. Eddy's Method.* As before, E and I are constant along the rib Piers immovable. Rib curve symmetrical about a vertical line. Fig. 429 shows such a rib under any loading. Its span is OB , which is taken as an axis X . The co-ordinates of any point m' of the rib curve are x and y , and z is the vertical intercept between m' and the special equilibrium polygon (as yet unknown, but to be constructed). Prof. Eddy's method will now be

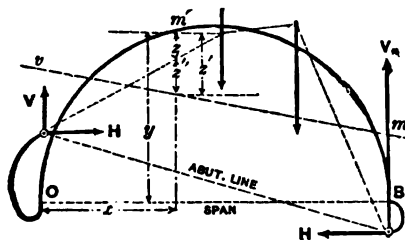

Fig. 429.

given for finding the special equil. polygon. The three conditions it must satisfy (see § 378, Class D, remembering that E and I are constant and that $M = Hz$ from § 367) are

$$\int_0^B z ds = 0; \int_0^B xz ds = 0 \text{ and } \int_0^B yz ds = 0 \quad \dots (1)$$

Now suppose the auxiliary reference line (straight) vm to have been drawn satisfying the requirements, with respect to the rib curve that

$$\int_0^B z' ds = 0; \text{ and } \int_0^B xz' ds = 0 \quad \dots (2)$$

in which z' is the vertical distance of any point m' from vm and x the abscissa of m' from O .

From Fig. 429, letting z' denote the vertical intercept (corresponding to any m') between the spec. polygon and the auxiliary line vm , we have $z = z' - z''$, hence the three conditions in (1.) become

$$\int_0^B (z' - z'') ds = 0; \text{ i.e., see eqs. (2) } \int_0^B z' ds = 0 \quad \dots (3)$$

* P. 14 of Prof. Eddy's book; see reference in preface of this work.

$$\int_0^B x(z'-z'')ds=0; \text{ i.e., see eqs. (2) } \int_0^B xz''ds=0 \quad (4)$$

$$\text{and } \int_0^B y(z'-z'')ds=0 \therefore \text{ by trans-} \int_0^B yz''ds = \int_0^B yz'ds \quad (5)$$

provided vm has been located as prescribed.

For graphical purposes, having subdivided the rib curve into an *even* number of small equal Δs 's, and drawn a vertical through the middle of each, we first, by § 377, locate *vm* to satisfy the conditions

$$\Sigma_0^B(x')=0 \text{ and } \Sigma_0^B(xz')=0 \quad . \quad . \quad (6)$$

(see eq. (2); the Δs cancels out); and then locate the special equilibrium polygon, with *vm* as a reference-line, by making it satisfy the conditions.

$$\Sigma_0^B(z'')=0 \quad (7); \quad \Sigma_0^B(xz'')=0 \quad (8); \quad \Sigma_0^B(yz'')=\Sigma_0^B(yz') \quad (9)$$

(obtained from eqs. (3), (4), (5) by putting $ds=\Delta s$, and cancelling).

Conditions (7) and (8) may be satisfied by an infinite number of polygons drawn to the given loading. Any one of these being drawn, as a trial polygon, we determine for it the value of the sum $\Sigma_0^B(yz'')$ by § 375, and compare it with the value of the sum $\Sigma_0^B(yz')$ which is independent of the special polygon and is obtained by § 375. [N.B. It must be understood that the quantities (lengths) x, y, z, z' , and z'' , here dealt with are those pertaining to the verticals drawn through the middles of the respective Δs 's, which must be sufficiently numerous to obtain a close result, and not to the verticals in which the loads act, necessarily, since these latter may be few or many according to circumstances, see Fig. 429]. If these sums are not equal, the pole distance of the trial equil. polygon must be altered in the proper ratio (and thus change the z'' 's in the inverse ratio) necessary to make these sums equal and thus satisfy condition (9). The alteration of the z'' 's, all in the same ratio, will

not interfere with conditions (7) and (8) which are already satisfied.

381. Detail of Construction of Last Problem. Symmetrical Arch-Rib of Fixed Ends.—As an example take a span of the St. Louis Bridge (assuming I constant) with "live load" covering the half span on the left, Fig. 430, where the vertical

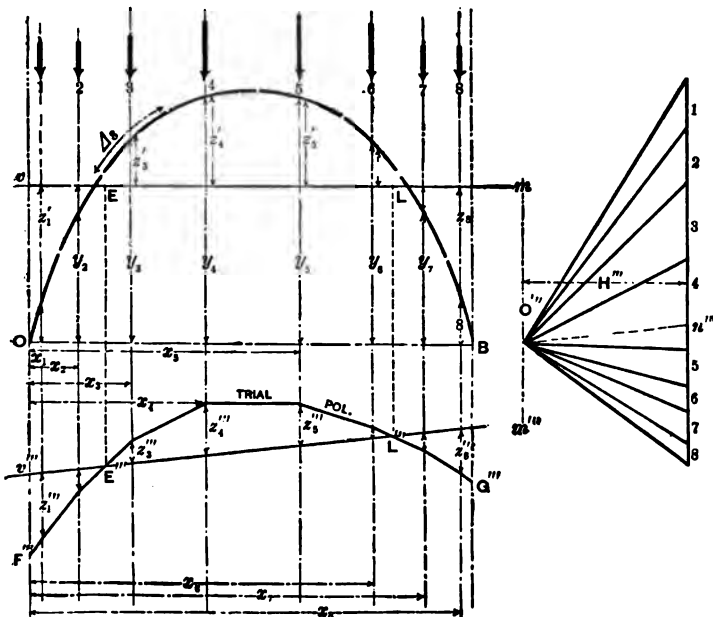

FIG. 430.

scale is much exaggerated for the sake of distinctness*. Divide into eight equal Δs 's. (In an actual example sixteen or twenty should be taken.) Draw a vertical through the

* Each arch-rib of the St. Louis bridge is a built up or trussed rib of steel about 530 ft. span and 52 ft. rise, in the form of a segment of a circle. Its moment of inertia, however, is not strictly constant, the portions near each pier, of a length equal to one twelfth of the span, having a value of I one-half greater than that of the remainder of the arc.

middle of each Δs . P_1 , etc., are the loads coming upon the respective Δs 's.

First, to locate vm , by eq. (6); from symmetry it must be horizontal. Draw a trial vm (not shown in the figure) and if the $(+z')$'s exceed the $(-z')$'s by an amount z_0' , the true vm will lie a height $\frac{1}{n} z_0'$ above the trial vm (or below, if vice versâ); $n =$ the number of Δs 's.

Now lay off the load-line on the right, (to scale), take any convenient trial pole O''' and draw a corresponding trial equil. polygon $F'''G'''$. In $F'''G'''$, by § 377, locate a straight line $v'''m'''$ so as to make $\Sigma_0^B(z''')=0$ and $\Sigma_0^B(xz''')=0$ (see Note (b) of § 377).

[We might now redraw $F'''G'''$ in such a way as to bring $v'''m'''$ into a horizontal position, thus: first determine a point n''' on the load-line by drawing $O''n''' \parallel$ to $v'''m'''$ take a new pole on a horizontal through n''' , with the same H''' , and draw a corresponding equil. polygon; in the latter $v'''m'''$ would be horizontal. We might also shift this new trial polygon upward so as to make $v'''m'''$ and vm coincide. It would satisfy conditions (7) and (8), having the same z'''' 's as the first trial polygon; but to satisfy condition (9) it must have its z'''' 's altered in a certain ratio, which we must now find. But we can deal with the individual z'''' 's just as well in their present positions in Fig. 430.] The points E and L in vm , vertically over E''' and L''' in $v'''m'''$, are now fixed; they are the intersections of the special polygon required, with vm .

The ordinates between $v'''m'''$ and the trial equilibrium polygon have been called z'' instead of z''' ; they are proportional to the respective z'''' 's of the required special polygon.

The next step is to find in what ratio the $(z''''$'s need to be altered (or H''' altered in inverse ratio) in order to become the $(z''$'s); i.e., in order to fulfil condition (9), viz.:

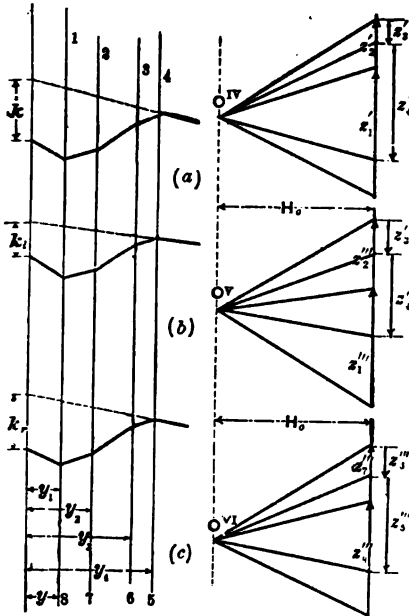

FIG. 431.

and from Fig. 431c

$$\Sigma_1^8(yz''') = H_0 k_r$$

[The same pole distance H_0 is taken in all these constructions] $\therefore \Sigma_1^8(yz''') = H_0(k_1 + k_r)$.

If, then, $H_0(k_1 + k_r) = 2H_0k$ condition (9) is satisfied by the z'''' 's. If not, the true pole distance for the special equil. polygon of Fig. 430 will be

$$H = \frac{k_1 + k_r}{2k} \cdot H'''$$

With this pole distance and a pole in the horizontal through n''' (Fig. 430) the force diagram may be completed for the required special polygon; and this latter may be constructed as follows: Beginning at the point E , in vm , through it draw a segment \parallel to the proper ray of the force diagram. In our present figure (430) this "proper ray" would be the ray joining the pole with the point of meeting of P_2 and P_3 on the load-line. Having this one seg-

$$\Sigma_1^8(yz''') = \Sigma_1^8(yz'') \quad (9)$$

This may be done precisely as for the rib with two hinges, but the negative (z'''')'s must be properly considered (§ 375) See Fig. 431 for the detail. Negative z'''' 's point upward.

From Fig. 431a

$$\Sigma_1^4(yz') = H_0 k$$

\therefore from symmetry

$$\Sigma_1^8(yz'') = 2H_0 k.$$

From Fig. 431b we have

$$\Sigma_1^4(yz''') = H_0 k_1$$

ment of the special polygon the others are added in an obvious manner, and thus the whole polygon completed. It should pass through L , but not O and B .

For another loading a different special equil. polygon would result, and in each case we may obtain the *thrust*, *shear*, and *moment* of stress couple for any cross-section of the rib, by § 367. To the stresses computed from these, should be added (algebraically) those occasioned by change of temperature and by shortening of the rib as occasioned by the thrusts along the rib. These "temperature stresses," and stresses due to rib-shortening, will be considered in a subsequent paragraph. They have no existence for an arch-rib of three hinges.

[NOTE.—If the moment of inertia of the rib is variable we put $\frac{z'}{n}$ for z' and $\frac{z''}{n}$ for z'' in equation (6), (7), (8), and (9), n having the meaning given in the Note in § 379 *a*, which see; and proceed accordingly].

381a. Exaggeration of Vertical Dimensions of Both Space and Force Diagrams.—In case, as often happens, the axis of the given rib is quite a flat curve, it is more accurate (for finding M) to proceed as follows:

After drawing the curve in its true proportions and passing a vertical through the middle of each of the equal Δs 's, compute the ordinate (y) of each of these middle points from the equation of the curve, and multiply each y by four (say). These quadruple ordinates are then laid off from the span upward, each in its proper vertical. Also multiply each load, of the given loading, by four, and then with these quadruple loads and quadruple ordinates, and the upper extremities of the latter as points in an exaggerated rib-curve, proceed to construct a special equilibrium polygon, and the corresponding force diagram by the proper method (for Class B , C , or D , as the case may be) for this exaggerated rib-curve.

The moment, Hx , thus found for any section of the ex-

aggerated rib-curve, is to be divided by four to obtain the moment in the real rib, in the same vertical line. To find the thrust and shear, however, for sections of the real rib, besides employing tangents and normals of the real rib we must draw, and use, another force diagram, obtained from the one already drawn (for the exaggerated rib) by reducing its *vertical* dimensions (only), in the ratio of four to one. [Of course, any other convenient number besides four, may be adopted throughout.]

382. Stress Diagrams.—Take an arch-rib of Class *D*, § 378, i.e., of fixed ends, and suppose that for a given loading (including its own weight) the special equil. polygon and its force diagram have been drawn [§ 381]. It is required to indicate graphically the variation of the three stress-elements for any section of the rib, viz., the thrust, shear, and mom. of stress-couple. *I* is constant. If at any point *m* of the rib a section is made, then the stresses in that section are classified into three sets (Fig. 432). (See §§ 295 and 367) and from § 367 eq. (3) we see that the vertical intercepts between the rib and the special equil. polygon being proportional to the products *H**z* or moments of the stress-couples in the corresponding sections form a moment diagram, on inspection of which we can trace the change in this moment, $H_z = \frac{p_2 I}{e}$, and

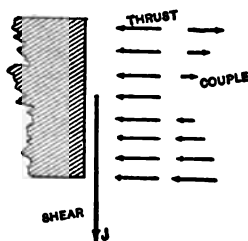

hence the variation of the stress per square inch, p_2 , (as due to stress couple alone) in the outermost fibre of any section (tension or compression) at distance *e* from the gravity axis of the section), from section to section along the rib.

By drawing through *O* lines *On'* and *Ot'* parallel respectively to the tangent and normal at any point *m* of the rib axis [see Fig. 433] and projecting upon them, in turn, the proper ray (*R*₃ in Fig. 433) (see eqs. 1 and 2 of § 367)

we obtain the values of the thrust and shear for the section at m . When found in this way for a number of points along the rib their values may be laid off as vertical lines from a horizontal axis, in the verticals containing the respective points, and thus a thrust diagram and a shear diagram may be formed, as constructed in Fig. 433. Notice that where the moment is a maximum or minimum the shear changes sign (compare § 240), either gradually or

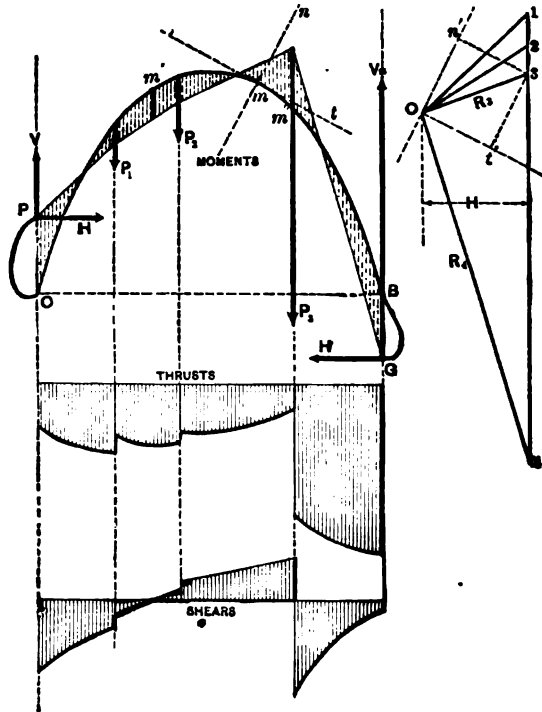

FIG. 433.

suddenly, according as the max. or min. occurs between two loads or in passing a load; see m' , e. g.

Also it is evident, from the geometrical relations involved, that at those points of the rib where the tangent-line is parallel to the "proper ray" of the force diagram, the thrust is a maximum (a local maximum) the moment (of

stress couple) is either a maximum or a minimum and the shear is zero.

$$\text{From the moment, } H_z = \frac{p_2 I}{e}, p_2 = \frac{H_z e}{I}$$

may be computed. From the thrust = $F p_1$, $p_1 = \frac{\text{thrust}}{F}$, (F = area of cross-section) may be computed. Hence the greatest compression per sq. inch ($p_1 + p_2$) may be found in each section. A separate stress-diagram might be constructed for this quantity ($p_1 + p_2$). Its max. value (after adding the stress due to change of temperature, or to rib-shortening, for ribs of less than three hinges), wherever it occurs in the rib, must be made safe by proper designing of the rib. The maximum shear J_m can be used as in §256 to determine thickness of web, if the section is I-shaped, or box-shaped. See § 295.

383. Temperature Stresses.—In an ordinary bridge truss and straight horizontal girders, free to expand or contract longitudinally, and in Classes A and B of § 378 of arch-ribs, there are no stresses induced by change of temperature; for the *form* of the beam or truss is under no constraint from the manner of support; but with the arch-rib of two hinges (hinged ends, Class C) and of fixed ends (Class D) having *immovable piers* which constrain the distance between the two ends to *remain the same* at all temperatures, stresses called "temperature stresses" are induced in the rib whenever the temperature, t , is not the same as that, t_0 , when the rib was put in place. These may be determined, as follows, as if they were the only ones, and then combined, algebraically, with those due to the loading.

384. Temperature Stresses in the Arch-Rib of Hinged Ends.—(Class C, § 378.) Fig. 434. Let E and I be constant, with

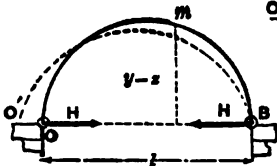

FIG. 434.

other postulates as in § 379. Let t_0 = temperature of erection, and t = any other temperature; also let l = length of span = OB (invariable) and η = co-efficient of linear expansion of the

material of the curved beam or rib (see § 199). At temperature t there must be a horizontal reaction H at each hinge to prevent expansion into the form $O'B$ (dotted curve), which is the form *natural* to the rib for temperature t and without constraint. We may \therefore consider the actual form OB as having resulted from the unstrained form $O'B$ by displacing O' to O , i.e., producing a horizontal displacement $O'O = l(t-t_0)\eta$.

But $O'O = \Delta x$ (see §§ 373 and 374); (N.B. B 's tangent has moved, but this does not affect Δx , if the axis X is horizontal, as here, coinciding with the span;) and the ordinate y of any point m of the rib is identical with its z or intercept between it and the spec. equil. polygon, which here consists of *one segment only*, viz.: OB . Its force diagram consists of a single ray $O_1 n'$; see Fig. 434. Now (§ 373)

$$\Delta x = \frac{1}{EI} \int_0^B My ds; \text{ and } M = Hz = \text{in this case, } Hy$$

$$\therefore l(t-t_0)\eta = \frac{H}{EI} \int_0^B y^2 ds; \left\{ \begin{array}{l} \text{hence for graphics, and} \\ \text{equal } \Delta s \text{ s, we have} \end{array} \right.$$

$$Ell(t-t_0)\eta = H \Delta s \Sigma_0^B y^2 \dots \dots (1)$$

From eq. (1) we determine H , having divided the rib-curve into from twelve to twenty equal parts each called Δs .

For instance, for wrought iron, t and t_0 , being expressed in Fahrenheit degrees, $\eta = 0.000066$. If E is expressed in lbs. per square inch, all linear quantities should be in inches and H will be obtained in pounds.

$\Sigma_0^B y^2$ may be obtained by § 375, or may be computed. H being known, we find the moment of stress-couple = Hy ,

at any section, while the thrust and shear at that section are the projections of H , i.e., of O_1n' upon the tangent and normal. The stresses due to these may then be determined in any section, as already so frequently explained, and then combined with those due to loading.

385. Temperature Stresses in the Arch-Ribs with Fixed Ends.— See Fig. 435. (Same postulates as to symmetry, E and I constant, etc., as in § 380.) t and t_0 have the same meaning as in § 384.

Here, as before, we consider the rib to have reached its actual form under temperature t by having had its span forcibly shortened from the length natural to temp. t , viz.: $O'B'$,

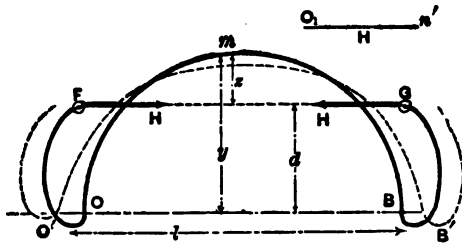

FIG. 435.

to the actual length OB , which the immovable piers compel it to assume. But here, since the tangents at O and B are to be the same in direction under constraint as before, the two forces H , representing the action of the piers on the rib, must be considered as acting on imaginary rigid prolongations at an unknown distance d above the span. To find H and d we need two equations.

From § 373 we have, since $M = Hz = H(y - d)$,

$$\Delta x, \text{ i.e., } \overline{O'O} + \overline{BB'}, \text{ i.e., } l(t - t_0)\eta, = \frac{H}{EI} \int_0^B (y - d)y ds \quad . \quad (2)$$

or, graphically, with equal Δs 's

$$EIl(t - t_0)\eta = H\Delta s \left[\sum_0^B y^2 - d \sum_0^B y \right] \quad . \quad . \quad (3)$$

Also, since there has been no change in the angle between end-tangents, we must have, from § 374,

$$\frac{1}{EI} \int_0^B M ds = 0; \text{ i.e., } \frac{H}{EI} \int_0^B z ds = 0; \text{ i.e., } \int_0^B (y - d) ds = 0$$

or for graphics, with equal Δs 's, $\Sigma^B y = nd \dots (4)$

in which n denotes the number of Δs 's. From (4) we determine d , and then from (3) can compute H . Drawing the horizontal FG , it is the special equilibrium polygon (of but one segment) and the moment of the stress-couple at any section = Hx , while the thrust and shear are the projections of $H=O_1n'$ on the tangent and normal respectively of any point m of rib.

For example, in one span, of 550 feet, of the St. Louis Bridge, having a rise of 55 feet and fixed at the ends, the force H of Fig. 435 is = 108 tons, when the temperature is 80° Fahr. higher than the temp. of erection, and the enforced span is $3\frac{1}{4}$ inches shorter than the span natural to that higher temperature. Evidently, if the actual temperature t is lower than that t_0 , of erection, H must act in a direction opposite to that of Figs. 435 and 434, and the "thrust" in any section will be *negative*, i.e., a pull.

386. Stresses Due to Rib-Shortening—In § 369, Fig. 407, the shortening of the element AE to a length $A'E$, due to the uniformly distributed thrust, p_1F , was neglected as producing indirectly a change of curvature and form in the rib axis; but such will be the case if the rib has *less than three hinges*. This change in the length of the different portions of the rib curve, may be treated as if it were due to a change of temperature. For example, from § 199 we see that a thrust of 50 tons coming upon a sectional area of $F = 10$ sq. inches in an iron rib, whose material has a modulus of elasticity = $E = 30,000,000$ lbs. per sq. inch, and a coefficient of expansion $\gamma = .0000066$ per degree Fahrenheit, produces a shortening equal to that due to a fall of temperature $(t_0 - t)$ derived as follows: (See § 199) (units, inch and pound)

$$(t_0 - t) = \frac{P}{FE\gamma} = \frac{100,000}{10 \times 30,000,000 \times .0000066} = 50^\circ$$

Fahrenheit.

Practically, then, since most metal arch bridges of classes C and D are rather flat in curvature, and the thrusts

due to ordinary modes of loading do not vary more than 20 or 30 per cent. from each other along the rib, an imaginary fall of temperature corresponding to an average thrust in any case of loading may be made the basis of a construction similar to that in § 384 or § 385 (according as the ends are *hinged*, or *fixed*) from which new thrusts, shears, and stress-couple moments, may be derived to be combined with those previously obtained for loading and for change of temperature.

387. Résumé—It is now seen how the stresses per square inch, both shearing and compression (or tension) may be obtained in all parts of any section of a solid arch-rib or curved beam of the kinds described, by combining the results due to the three separate causes, viz.: the load, change of temperature, and rib-shortening caused by the thrusts due to the load (the latter agencies, however, coming into consideration only in classes *C* and *D*, see § 378). That is, in any cross-section, the stress in the outer fibre is, [letting T_h' , T_h'' , T_h''' , denote the thrusts due to the three causes, respectively, above mentioned; $(Hz)'$, $(Hz)''$, $(Hz)'''$, the moments]

$$= \frac{T_h' \pm T_h'' + T_h'''}{F} \pm \frac{e}{I} [(Hz)' \pm (Hz)'' \pm (Hz)'''] \quad . . . (1)$$

i.e., lbs. per sq. inch compression (if those units are used).

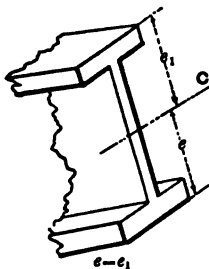

FIG. 436.

The double signs provide for the cases where the stresses in the outer fibre, due to a single agency, may be tensile. Fig. 436 shows the meaning of e (the same used heretofore) I is the moment of inertia of the section about the gravity axis (horizontal) C . F = area of cross-section. [$e_1 = e$; cross section symmetrical about C]. For a given loading we

may find the maximum stress in a given rib, or design the rib so that this maximum stress shall be safe for the material employed. Similarly, the resultant shear (total, not

per sq. inch) = $J' \pm J'' \pm J'''$ is obtained for any section to compute a proper thickness of web, spacing of rivets, etc.

388 The Arch-Truss, or braced arch. An open-work truss, if of homogeneous design from end to end, may be treated as a beam of constant section and constant moment of inertia, and if curved, like the St. Louis Bridge and the Coblenz Bridge (see § 378, Class D), may be treated as an arch-rib.* The moment of inertia may be taken as

$$I = 2 F_1 \left(\frac{h}{2} \right)^2$$

where F_1 is the sectional area of one of the pieces \uparrow to the curved axis midway between them, Fig. 437, and h = distance between them.

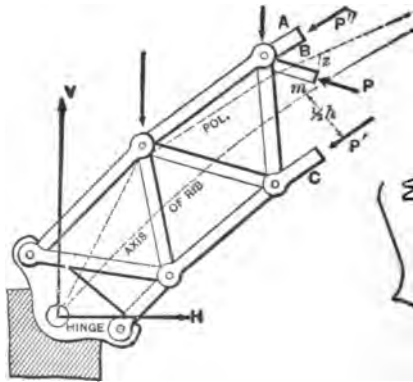

FIG. 438.

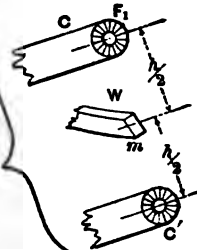

FIG. 437.

Treating this curved axis as an arch-rib, in the usual way (see preceding articles), we obtain the spec. equil. pol. and its force diagram for given loading. Any plane \uparrow to the rib-axis, where it crosses the middle m of a "web-member," cuts three pieces, A , B and C , the total com-

*The St. Louis Bridge is not strictly of constant moment of inertia, being somewhat strengthened near each pier

pressions (or tensions) in which are thus found: For the point m , of rib-axis, there is a certain moment = Hx , a thrust = T_h , and a shear = J , obtained as previously explained. We may then write $P \sin \beta = J$ (1) and thus determine whether P is a tension or compression; then putting $P' + P'' \pm P \cos \beta = T_h$ 2 (in which P is taken with a plus sign if a compression, and minus if tension); and

$$(P' - P'') \frac{h}{2} = Hx \quad (3)$$

we compute P' and P'' , which are assumed to be *both compressions* here. β is the angle between the web member and the tangent to rib-axis at m , the middle of the piece. See Fig. 406, as an explanation of the method just adopted.

HORIZONTAL STRAIGHT GIRDERS.

389. Ends Free to Turn.—This corresponds to an arch-rib with hinged ends, but it must be understood that there is no hindrance to horizontal motion. (Fig. 439.) In

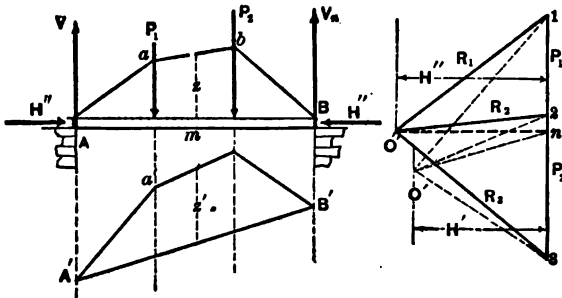

FIG. 439.

treating a straight beam, *slightly bent under vertical forces only* (as in this case with no horizontal constraint), as a

particular case of an arch-rib, it is evident that since the pole distance must be zero, the special equil. polygon will have all its segments vertical, and the corresponding force diagram reduces to a single vertical line (the load line). The first and last segments must pass through A and B (points of no moment) respectively, but being vertical will not intersect P_1 and P_2 ; i.e., the remainder of the special equilibrium polygon lies at an infinite distance above the span AB . Hence the actual spec. equil. pol. is useless.

However, knowing that the shear, J , and the moment M (of stress couple) are the only quantities pertaining to any section m (Fig. 439) which we wish to determine (since there is no thrust along the beam), and knowing that an imaginary force H' , applied horizontally at each end of the beam, would have no influence in determining the shear and moment at m as due to the new system of forces, we may therefore obtain the shears and moments graphically from this new system (viz.: the loads P , etc., the vertical reactions V and V_n , and the two equal and opposite H' 's). [Evidently, since H' has no moment about the neutral axis (or gravity axis here), of m , the moment at m will be unaffected by it; and since H' has no component \perp to the beam at m , the shear at m is the same in the new system of forces, as in the old, before the introduction of the H' 's.]

Hence, lay off the load-line 1 . . 2 . . 3, Fig. 439, and construct an equil. polyg. which shall pass through A and B and have any convenient arbitrary H'' (force) as a pole distance. This is done by first determining n' on the load-line, using the auxiliary polygon $A'a'B'$, to a pole O' (arbitrary), and drawing $O'n' \parallel$ to $A'B'$. Taking O'' on a horizontal through n' , making $O''n' = H''$, we complete the force diagram, and equil. pol. AaB . Then, z being the vertical intercept between m and the equil. polygon, we have: Moment at $m = M = H''z$ (or $= H'z'$ also), and shear at m , or $J = 2 \dots n'$, i.e., = projection of the proper ray R_n or $O'' \dots 2$, upon the vertical through m . Similarly we obtain M and J at any other section for the given load. (See

§§ 329, 337 and 367). The moment of inertia need not be constant in this case.

390. Straight Horizontal Prismatic Girder of Fixed Ends at Same Level.—No horizontal constraint, hence no thrust. I constant. Ends at same level, with end-tangents horizontal. We may consider the whole beam free (cutting close to the walls) putting in the unknown upward shears J_o and J_n ,

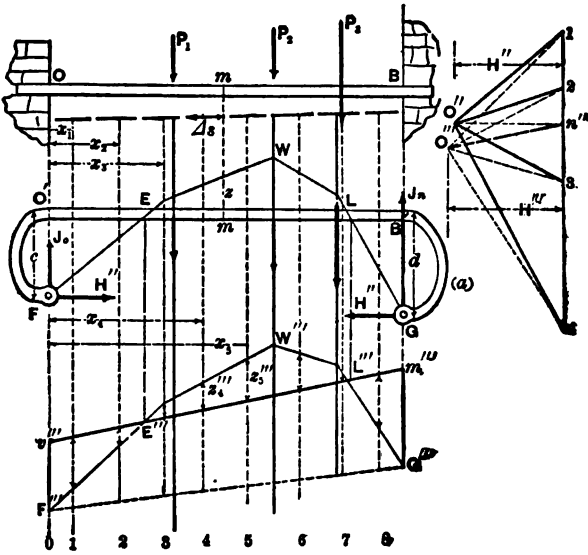

FIG. 440.

and the two stress couples of unknown moments M_o and M_n at these end sections. Also, as in § 388, an arbitrary H'' horizontal and in line of beam at each extremity. Now (See Fig. 33) the couple at O and the force H'' are equivalent to a single horizontal H'' at an unknown vertical distance c below O ; similarly at the right hand end. The special polygon FG is to be determined for this new system, since the moment and shear will be the same at any section under this new system as under the real system. The conditions for determining it are as follows: Since the end-tangents are fixed, $\Sigma M \Delta s = 0 \therefore \Sigma^B_o z \Delta s = 0$ and since

O 's displacement relatively to B 's tangent is zero we have $\Sigma Mx\Delta s=0 \therefore \Sigma H'zx\Delta s=0 \therefore \Sigma xz\Delta s=0$. See § 374. Hence for Equal Δs 's, $\Sigma(z)=0$ and $\Sigma(xz)=0$. Now for any pole O''' draw an equil. pol. $F'''G'''$ and in it (by § 377; see Note) locate $v'''m'''$ so as to make $\Sigma(z''')=0$ and $\Sigma(xz''')=0$. Draw verticals through the intersections E''' and L''' , to determine E and L on the beam, these are the points of inflection (i.e., of zero moment), and are points in the required special polygon FG .

Draw $O'''n''' \parallel$ to $v'''m'''$ to fix n''' . Take a pole O'' on the horizontal through n''' , making $\mathcal{J}'x''=H''$ (arbitrary), draw the force diagram O'' 1234 and a corresponding equilibrium polygon beginning at E . It should cut L , and will fulfil the two requirements $\Sigma_0^B(z)=0$ and $\Sigma_0^B(xz)=0$, with reference to the axis of the beam $O'B'$. The moment of the stress-couple at any section m will be $M=H''z$, and the shear J = the projection of the "proper ray" of the force diagram O'' . . 1, 2, etc., upon the vertical (not in the trial diagram O''' . . 1, 2, etc.). As far as the moment is concerned the trial polygon $F'''G'''$ will serve as well as the special polygon FG ; i.e., $M=H'''z'''$ as well as $H''z$, H'' being the pole-distance of O'' ; but for the shear we must use the rays of the final and not the trial diagram.

The peculiarity of this treatment of straight beams, considered as a particular case of curved beams, consists in the substitution of an imaginary system of forces involving the two equal and opposite, and arbitrary H 's, for the real system in which there is no horizontal force and consequently no "special equilibrium polygon," and thus determining all that is desired, i.e., the moment and shear at any section.

In the polygon FG the student will recognize the "moment-diagram" of the problems in Chaps. III and IV.

He will also see why the shear is proportional to the slope $\frac{dM}{dx}$ of the moment curve in those chapters. For example, the "slope" of the second segment of the polygon FG , that segment being \parallel to O'' 2, is

$$\text{tang. of angle } 2O'n'' = \overline{2n''} + \overline{O'n''} = \text{shear} \div H'$$

and similarly for any other segment; i.e., the tangent of the inclination of the "moment curve," or line, is proportional to the shear.

It is also interesting to notice with the present problem of a straight beam, that in the conditions

$$\Sigma(z\Delta s) = 0 \text{ and } \Sigma(z\Delta s)x = 0,$$

for locating the polygon FG , each Δs is \perp to its z , and that consequently each $z\Delta s$ is the area of a small vertical strip of area between the beam and the polygon, and $(z\Delta s)x$ is the "moment" of this strip of area, about O' the origin of x . Hence these conditions imply; *first*, that the area EWL between the polygon and the axis of the beam on one side is equal to that ($O'FE + LB'G$) on the other side, and, *secondly*, that the centre of gravity of EWL lies in the same vertical as that of $O'FE$ and $LB'G$ combined. Another way of stating the same thing is that, if we join FG , the area of the trapezoid $F'O'B'G$ is equal to that of the figure $FEWLG$, and their centres of gravity lie in the same vertical. A corresponding statement may be made (if we join $F''G''$) for the trapezoid $F''v''m''G''$ and figure $F''E''W''L''G''$,

CHAPTER XII.

GRAPHICS OF CONTINUOUS GIRDERS.

[MAINLY DUE TO PROF. MOHR, OF AIX-LA-CHAPELLE]

391. The Elastic Curve of a Horizontal Loaded Beam, Homogeneous and Originally Straight and Prismatic, is an Equilibrium Polygon, whose "load-line" is vertical and consists of the successive products Mdx [treated as if they were loads each applied through the middle of its proper dx], and whose "pole distance" is EI . Fig 441 (exaggerated).

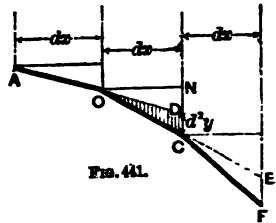

Let AO and OC be any two consecutive equal elements of a very flat elastic curve (as above described). Prolong AO to cut NC . Then from § 231, eq. (7), we have

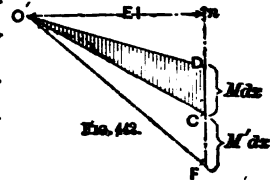

$$\frac{d^2y}{dx} = \frac{(Mdx)}{EI} \dots \dots \dots (1)$$

where $d^2y = \overline{DC}$; and, hence, if a triangle (Fig. 442) $O'D'C'$, be formed with $O'D' \parallel$ to OD , $O'C' \parallel$ to OC , and $D'C'$ vertical, while its (horizontal) altitude $O'n$ is made equal, by scale, to EI of the beam, then from the similarity of the triangle ODC and $O'D'C'$ and the proportion in eq. (1) we see that $D'C'$ must represent the product Mdx on the same scale by which $O'n$ represents EI . M is the moment of

the stress-couple at the section whose neutral axis is projected in O .

Similarly, if M' is the moment of the stress-couple at C , and we draw $O'F'$, \parallel to CF , $C'F'$ must represent $M'dx$ (on same scale). It is therefore apparent that the line $AO'CF'$ bears to the figure $O'D'C'F'$ the same relation which an equilibrium polygon (for vertical forces) does to its force diagram, the "loads" of the force-diagram being the successive values of Mdx laid off to scale, while its "pole-distance" is EI laid off on the same scale. [As if Mdx and $M'dx$ were loads suspended at O and C respectively.]

Practically, since any actual elastic curve is very flat, and since a change of pole-distance will change all vertical dimensions of the equilibrium polygon in an inverse equal ratio, we may exaggerate the vertical dimensions of the elastic curve by choosing a pole distance smaller than EI in any convenient ratio, n . Any deflection in the elastic curve thus obtained will be greater than its true value in the same ratio n .

Graphically, in order to draw exaggerated elastic curves according to this principle, we obtain approximate results by dividing the length of the beam into a number of equal Δx 's, draw verticals through the middles of the Δx 's as "force-verticals," and lay off as a "load-line" to any convenient scale the corresponding values of $M\Delta x$ in their proper order.

The quality of the product $M\Delta x$ is evidently (length)² \times force, and with the foot and pound as units such a product may be called so many (sq. ft.) (lbs.). It will be noticed that these products ($M\Delta x$) are proportional to, and may be represented by, the areas of the corresponding vertical strips of the "moment-diagram" proper to the case in hand. These strips together make up the "*moment-area*," as it may be called, lying between the moment curve and its horizontal axis (which is the axis of the beam itself, according to §§ 389 and 390).

392. **Mohr's Theorem.**—The principle of the previous paragraph may therefore be enunciated as follows: *That just as the moment curve (of a straight prismatic horizontal beam) between two consecutive supports is an equilibrium polygon for the loading between those supports, so also is the elastic curve itself an equilibrium polygon for the "moment-area" considered as a loading.*

In dealing with the moment-curve of a single span the pole distance is arbitrary (§§ 389 and 390), but the position of the pole relatively to the load line in other respects, and the location of the moment-curve (equil-pol.) relatively to the beam (considered to be still straight for this purpose), depend on whether the beam simply rests on the two supports, without projecting beyond; or is built in, and at what angles; or as with a continuous girder, on the inclination of the tangent-lines at the supports, as influenced by the presence of loads on all the spans, and on whether all supports are on the same level or not.

For example, in § 389, for a single span, the ends of beam being simply supported without overhanging, the pole O'' must be on a horizontal through n' , and the moment curve must pass through the extremities A and B of the beam, thus giving a "moment-area" lying entirely on one side of the beam (or axis from which the moment ordinates, z , are to be measured); whereas, in § 390, also a single span, where the ends of the beam are built in horizontally and at the same level, the pole must be taken on the horizontal through n'' , and the moment-curve $FEWL$ must intersect the beam in the points E and L (E , L , and n'' being found as prescribed in that problem), and thus lies partly above and partly below the beam. It will be necessary, later, to distinguish the upper and lower parts of the moment-area as positive and negative.

In drawing the equilibrium polygon which constitutes the actual elastic curve, however, and hence making use of the successive small vertical strips of the moment-area, (when found) as if they were loads, to form a load-line according to a convenient scale, the pole distance is not ar-

bitrary but must be = EI on the same scale. Still, since for convenience we must always greatly exaggerate the vertical scale of the elastic curve, we may make the pole distance = $EI \div n$ and thus obtain an elastic curve whose vertical dimensions are n times as large as those of the real curve; while the position of the pole will depend in the direction of the tangent lines at the extremities of the span. An example will now be given.

393. Example of an Elastic Curve (Beam Prismatic) Drawn as an Equilibrium Polygon Supporting the Moment-Area as Loading. —Let the beam be simply supported at its extremities (at the same level), and bear a single eccentric load P , Fig. 443, its own weight being neglected. The moment-area

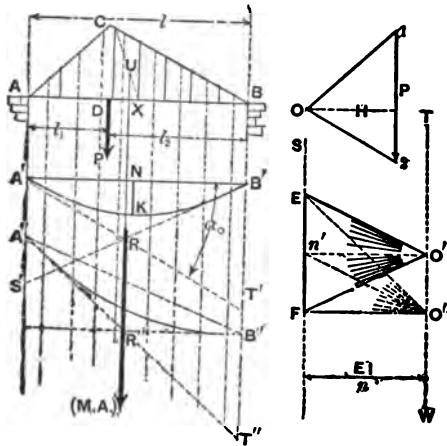

FIG. 443.

consists of a triangle ACB [see first part of § 260, or use the graphic method of § 389, thus utilizing a force diagram 012.], its altitude being the moment represented by the ordinate CD and having a value = $\frac{Pl_1l_2}{l}$. Hence the total

$$\text{moment-area} = \frac{1}{2} \text{base } \overline{AB} \times \text{mom. } \overline{CD}$$

$$\text{i.e.,} = \frac{Pl_1l_2}{l} \times \frac{1}{2} l = \frac{1}{2} Pl_1l_2$$

Divide AB into (say) eight equal Δx 's (eight are rather few in practice; sixteen or twenty would be better) and draw a vertical through the middle of each. Note the portion of each of these vertical intercepts between the axis of the beam and the moment-curve ACB . The products $M \Delta x$ for the different subdivisions are proportional to these intercepts, since all the Δx 's are equal, and are the respective moment-areas of the Δx 's.

Treating these products as if they were loads, we lay off the corresponding intercepts (or their halves, or quarters, or other convenient fractional part or multiple), from E downwards to form a vertical "load-line," beginning with the left-hand intercept and continuing in proper order.

As to what scale this implies, we determine by dividing the total moment-area thus laid off, viz. : $\frac{1}{2} Pl_1 l_2$, say in (sq. in.) (lbs.), by the length of EF in inches, thus obtaining the number of (sq. in.) (lbs.) which each linear inch of paper represents.

On this scale the number of inches of paper required to represent the EI of the beam is so enormous, that in its stead we use the n th portion, n being an arbitrary abstract number of such magnitude as to make $EI \div n$ a convenient pole-distance, TS .

The proper position of the pole O' on the vertical TW , is fixed by the fact that the elastic curve, beginning at A , must terminate in B , at the same level as A . Hence, assuming any trial pole as O'' , and drawing rays in the usual manner (except that, as henceforth, the pole is taken on the right of the "load-line," instead of on the left, so as to make the resulting equilibrium polygon correspond in direction of curvature to the actual elastic curve), we draw the corresponding equilibrium polygon $A''B''$. Determining n' by drawing through O'' a line \parallel to the right line $A''O''$, we draw a horizontal through n' to intersect TW in O' , the required pole.

With O' as pole a new equilibrium polygon begun at A' will terminate in B' and its vertical ordinates will be n times as great as those of corresponding points on the

actual elastic curve AB . The same relation holds between the tangents of the angle of inclination to the horizontal at corresponding points (i.e., those in same vertical) of the two curves.

394. Numerical Case of Foregoing Example.—With the inch and pound as units, let $P = 120$ lbs., $l_1 = 40$ in., $l_2 = 80$ in. while the prismatic beam is of timber having a modulus of elasticity $E = 2,000,000$ lbs. per sq. inch, and is rectangular in section, being 2 in. wide and 4 in. high, so that (its width being placed horizontally) the moment of inertia of the section is $I = \frac{1}{12} bh^3 = \frac{1}{12} \times 2 \times 64 = 10\frac{2}{3}$ bi-quadratic inches (§ 90.) Required the maximum deflection. Adopting 1:20 as the scale for distances (i.e., one linear inch of paper to twenty inches of actual distance) we make the horizontal AB 6 in. long, Fig. 443, and AD 2 in., taking a point C at convenience in the vertical through D , and joining AC and CB , thus determining the moment-diagram for this case. [As to what pole distance, H , is implied in this selection of C , is immaterial in this simple case of a single load; hence we do not draw the corresponding force-diagram at all.] We divide AB into eight equal parts and draw a vertical through the middle of each. The intercepts, in these verticals, between AB and the broken line ACB we lay off from E toward F as prescribed in § 393. (By taking DC small enough the line EF will not be inconveniently long.)

Suppose this length EF measures 6.4 inches on the paper (as in the actual draft by the writer). Since it represents a *moment-area* of

$\frac{1}{2} Pl_1 l_2 = \frac{1}{2} \times 120 \times 40 \times 80 = 192,000$ (sq. in.) (lbs.), the scale of our "moment-area-diagram," as we may call it, must be $192,000 \div 6.4 = 30,000$ (sq. in.) (lbs.) per linear inch of paper.

Now $EI = 21,333,333$ (sq. in.) (lbs.), which on the above scale would be represented by 711 linear inches of paper. With $n = 100$, however, we lay off $ST = EI \div n = 7.11$ inches of paper as a pole distance, and with a trial pole O'' in

the vertical TW draw the trial equilibrium polygon or elastic curve $A''B''$, and with it determine n' , then the final polygon $A'B'$ as already prescribed. In $A'B'$ we find the greatest ordinate, NK , to measure 0.88 inches of paper, which represents an actual distance of $0.88 \times 20 = 17.6$ inches. But the vertical dimensions of the exaggerated elastic curve $A'B'$ are $n=100$ times as great as those of the actual, hence the actual max. deflection is $d=17.6 \div n=0.176$ in. [This maximum deflection could also be obtained from the oblique polygon $A''B''$ whose vertical dimensions are equal to those of $A'B'$. By the formula of § 235 we obtain $d=0.174$ inches.]

395. Direction of End-Tangents of Elastic Curve in the Foregoing Problem.—As an illustration bearing on subsequent work let us suppose that the only result required in § 394 is $\tan \alpha_0$, i.e., the tangent of the angle $B'A'T'$, which the tangent-line $B'T'$ to the elastic curve at the extremity A' , Fig. 343, makes with the horizontal line $A'B'$, ($\tan \alpha_0$ is called the “slope,” at A .) Let $B'S'$ be the tangent-line at B' . These two “end-tangents” are parallel respectively to EO' and FO' , and intersect at some point R . Now since $A'KB'$ is an equilibrium polygon sustaining an imaginary set of loads represented by the successive vertical strips of the moment-area ACB , the intersection R must lie in the vertical containing the centre of gravity, U , of that moment-area [§ 336].

Hence, if the vertical containing U is known in advance, or, as in the present case, is easily constructed without making the strip-subdivision of § 394, we may determine the end-tangents very briefly by considering the whole moment-area, $M.A.$, (considered as a load) applied in the vertical through U , as follows:

Since ACB is a triangle, we find U by bisecting AB in X , joining CX , and making $XU = \frac{1}{3} XC$, and then draw a vertical through U . Laying off $EF=6.4$ inches [so as to represent a moment-area of 192,000 (sq. in.) (lbs.) on a scale of 30,000 (sq. in.) (lbs.) per linear inch of paper],

and making $ST=7.11$ inches as before, we assume a trial pole O'' on TW , draw the two rays $O''E$ and $O''F$, construct the corresponding trial polygon of two segments $A''R''B''$, for the purpose of finding n' . With a pole O' on TW and on a level with n' we draw the two rays $O'E$ and $O'F$, and the corresponding segments $A'R$, and RB' . (B' should be on a level with A' , as a check.) These two segments are the end-tangents required.

We have, therefore,

$$\tan \alpha_0 = \overline{B'T''} \div \overline{A'B'} = \overline{B'T'''} \div \overline{A'B'}$$

In the present numerical problem we find $B'T''$ to measure 3 in. of paper, i.e., 60 in. of actual distance for the exagg. elastic curve, and therefore 0.60 in. in the real elastic curve (with $n = 100$)

$$\therefore \tan. \alpha_0 = \frac{0.60 \text{ in.}}{120 \text{ in.}} = 0.005$$

It is now evident that the position and direction of the end-tangents of the elastic curve lying between any two supports are independent of the mode of distribution of the moment-area so long as the amount of that moment-area and the position of its centre of gravity remain unchanged. This relation is to be of great service.

396. Re-Arrangement of the Moment-Area.—As another illustration conducing to clearness in later constructions, let us determine by still another method the end-tangents of the beam of §§ 394 and 395. See Fig. 444. As already seen, their location is independent of the arrangement of the moment-area between. Let us re-arrange this moment-area, viz., the triangle ACB , in the following manner :

By drawing AX parallel to BC , and prolonging BC to V in the vertical through A , we may consider the original moment-area ACB to be compounded of the positive mom.-area $VBXA$, a parallelogram, with its gravity-vertical passing through D , the middle of the span ; of the negative mom.-area VCA , a triangle whose gravity-vertical passes

through D_1 making $AD_1 = \frac{1}{3} AD$; and of another *negative* mom.-area, the triangle ABX , whose gravity-vertical passes through D_3 at one-third the span from B . That is, the (ideal) positive load ACB is the resultant of the positive load $(M.A.)_2$ and the two negative loads (or upward pulls) $(M.A.)_1$ and $(M.A.)_3$, and may therefore be replaced by them without affecting the location of the end-tangents, at A

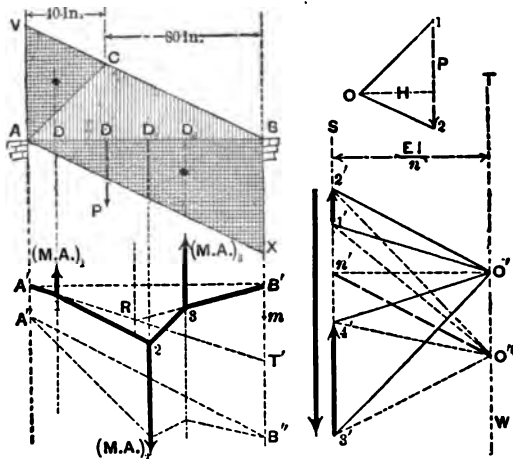

FIG. 444.

and B , of the elastic curve AB . These three moment-areas are represented by arrows, properly directed, in the figure, but must not be confused with the actual loads on the beam (of which, here, there is but one, viz., P).

From the given shapes and dimensions, since $ACB = 192,000$ (sq. in.) (lbs.), we easily derive by geometrical principles :

$$\begin{aligned} (M.A.)_2 &= +576,000 \text{ (sq. in.) (lbs.)} \\ (M.A.)_1 &= -96,000 \text{ " " " " } \\ (M.A.)_3 &= -288,000 \text{ " " " " } \end{aligned}$$

Hence, with a pole distance $EI \div n = 7.11$ in. as before, and a "moment-load-line" formed of $1'2' = (M.A.)_1$, (on scale of 30,000 (sq. in. lbs.) to one inch) $2'3' = (M.A.)_2$, and $3'4' = (M.A.)_3$, first with a trial pole O'' , construct the trial

polygon $A''B''$, and find n' in usual way (§ 337); then take a pole O' on the horizontal through n' and the vertical TW , and draw the new polygon $A' 123 B'$. It should pass through B' on a level with A' , and $A'1$ and $B'3$ are the required end-tangents (of the exagg. elastic curve).

[NOTE—If B' were not at the same level as A' , but (say) 0.40 in. below it, B' should be placed at m , a distance $\frac{0.4 \times 100}{20} = 2$ inches (on the paper) below its present position, (since the distance scale is 1:20 and $n = 100$, in this case) and the “abutment-line” of final polygon would be $A'm$].

Of course, this special re-arrangement of the moment-area is quite superfluous in the present problem of a discontinuous girder (not built in), but considerations of this kind will be found indispensable with the successive spans of a continuous girder.

397. Positive and Negative Moment-Areas in Each Span of a Continuous Girder (Prismatic).—In the foregoing problem of a discontinuous girder (covering one span only) not built in at the ends (otherwise it would be classed among continuous girders), the moment-curve, or equilibrium polygon of arbitrary H , is easily found by § 389 *without the aid of the elastic curve*, and the *end moments are both zero*; (i.e., the moment-curve meets the beam in the end-verticals) but in each span of a continuous girder the end-moments are not zero (necessarily), and the points in the end-verticals where the moment-curve must terminate (for an assumed H) can not be found without the use of the elastic curve (or of some of its tangents) *of the whole beam*, dependent, as it is, upon the loading on all the spans, and the heights of the supports.

Let Fig. 445 show, in general, any one span of a prismatic continuous girder (*prismatic*; hence I is constant), between two consecutive supports A_0 and B_0 . P_1, P_2 , etc., are the loads on the span.

[If the displacement of A_0 relatively to the end-tangent at B_0 , and the angle between the end-tangents (of elastic

curve) were known, the moment-curve or equilibrium polygon FWG , (AB being the axis of beam) might be found by a process similar to that in § 390, but the elastic curves in successive spans are so inter-dependent that the above elements can not be found directly.]

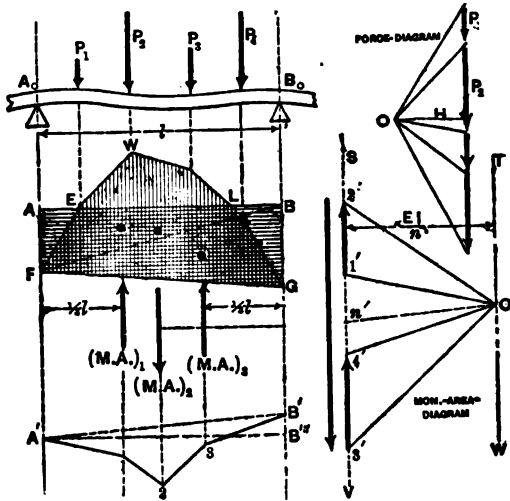

FIG. 445.

We now suppose, for the sake of discussion, that the whole girder has been investigated (by a process to be presented) for the given loads, spans, positions of supports, etc., and then the moment-curve $FEWLG$ found, with the corresponding force-diagram, for the span in the figure and some arbitrary H . The horizontal line AB represents the axis of the beam (for this purpose considered straight and horizontal) as an axis from which to measure the moment ordinates.

Thus, the moment (of the stress-couple) at A is $= H \times \overline{AF}$; at B , $H \times \overline{BG}$; at E and L , zero (points of inflection).

Now, according to the usual conceptions of analytical geometry, we may consider the portion EWL , of the moment-area, above AB as positive, and those below, AEF and LBG , as negative; but since not one of these three

areas, nor the position of its gravity-vertical, is known in advance, since they are not independent of the other spans, a more advantageous re-arrangement of the moment-area may be made thus:

Join FG and FB , and we may consider the original moment-area replaced by the following three component areas: the *positive moment-area* $FEWLGF$ (shaded by vertical lines); the *negative triangular moment-area* AFB ; and the *negative triangular moment-area* BFG (the negative moment-areas being shaded by horizontal lines). (In subsequent paragraphs, by positive and negative moment-areas will be implied those just mentioned.)

These three moment-areas, treated as loads, each applied in its own gravity-vertical, and considered in any order, may be used instead of the real distributed moment-area, *as far as determining, or dealing with, the end-tangents of the elastic-curve at A_0 and B_0 is concerned* (§ 396), and the following advantages will have been gained:

(1.) The *amount* of the positive moment-area, $(M.A.)_2$ in Fig. 445, (depending on the area lying between the polygon $FEWG$ and the abutment-line FG of the latter), and the *position of its gravity-vertical*, are *independent of other spans*, and can be *easily found in advance*, since *this moment-area and gravity-vertical are the same as if the part of the beam covering this span were discontinuous and simply rested on the supports A_0 and B_0 , as in § 389*.

(2.) The gravity-vertical of the left-hand negative moment-area, $(M.A.)_1$, is always one-third the span from the left end-vertical, A_0A' ; that of the other, $(M.A.)_3$, an equal distance from the right end-vertical, B_0B' .

(3.) The two (right and left) negative moment-areas are triangular, each having the whole span l for its altitude, and for its base the intercept AF (or BG) on which the end-moment depends. Hence, if the amounts of these negative moment-areas have been found in any span, we may compute the values which AF and BG must have for a given H , and thus determine the terminal points F and G of the moment-curve of that span (for that value of H).

For example, if $(M.A.)_1$ has been found (by a process not yet given) to be 160,000 (sq. in.) (lbs.) while $AB = l = 160$ in., then the moment M_A which AF represents, is computed from the relation

$$(M.A.)_1 = \frac{1}{2} \overline{AB} \times M_A$$

$$\text{or, } M_A = \frac{2 \times 160,000}{160} = 2000. \text{ in. lbs.}$$

If H has been chosen = 100 lbs. we put $H \times \overline{AF} = 2000$ and obtain $\overline{AF} = 20$ inches of actual distance, so that with a scale of 1:20 for distances \overline{AF} would be one linear inch of paper. (Of course, in computing \overline{BG} the same value of H must be used.) With $H = 100$ lbs., then, and F and G as known points of the equilibrium polygon $FEWG$, it is easily drawn by the principles of § 341.

We thus notice that the *amounts* of the two negative moment-areas are the only elements affected by the *continuity* of the girder, in this re-arrangement of the actual moment-areas.

In the lower part of Fig. 445 A' and B' represent the extremities of the (exagg.) elastic curve, the vertical distance $B'B''$, of B' from the horizontal through A' (in case the two supports A_0 and B_0 are not at same level, as we here suppose for illustration) being laid off in accordance with the principles of the note in § 396.

NOTE.—It is now evident that if the “*false polygon*” (as it will be called) $A'123B'$ has been obtained (and means for doing this will be given later) in which the first and last segments are the end tangents of the (exagg.) elastic curve, and which bears the same relation to the three moment areas just mentioned, as that illustrated in Fig. 444, we may proceed further to determine the amounts of $(M.A.)_1$ and $(M.A.)_2$, as follows, by completing the moment-area diagram :

Having laid off the known $(M.A.)_2$ (or positive moment-area) = $2'3'$, and $ST = EI \div n$, a line parallel to 12 drawn through 2', determines the pole O' , through which paral-

lels to $A'1$ and $B'3$ will fix $1'$ and $4'$ on the vertical SV , and thus determine $1'2'=(M.A.)_1$, and $3'4'=(M.A.)_3$. Their numerical values are then computed in accordance with the scale of the moment-area diagram.

The polygon $A'123B'$ will be called the "*false polygon*" of the span in question, its end-segments being the end-tangents of the elastic curve.

398. Values of the Positive Moment-Area in Special Cases— For several special cases these are easily computed, and as an illustration, Fig. 446 shows a continuous girder, AF

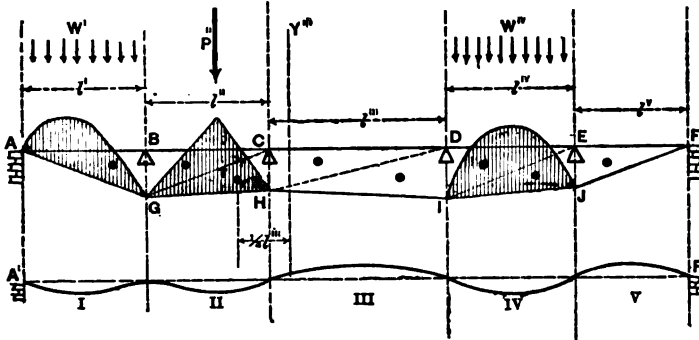

FIG. 446.

of five spans, all six supports on a level, and the weight of the beam neglected. At the extremities A and F , as at the other supports, the beam is not built in, but simply touches each support in one point; hence the moments at A and F are zero, i.e., the moment curve must pass through A and F , so that in the first span the left negative moment-area, and in the fifth span the right negative moment-area, are zero. The positive moment-areas are shaded.

On the first span is placed a uniformly distributed load W' over the whole span l' . \therefore the positive moment-area for that span is the same as in the case of Fig. 235 [see (1) § 397] and being represented by a parabolic segment whose area is two-thirds that of the circumscribing rectangle, its value is

$$(M.A.)_2' = \frac{2}{3} \cdot \frac{1}{8} Wl' \times l' = \frac{1}{12} Wl'^2 \quad . \quad . \quad (1)$$

[see eq. (2) § 242], while its gravity-vertical bisects the span.

The only load on the second span is a concentrated one, P' , at distances l_1'' and l_2'' from the extremities of the span; hence the positive moment-area is triangular and has a value

$$(M.A.)_2'' = \frac{1}{2} P' l_1'' l_2'' \quad . \quad . \quad . \quad (2)$$

as in § 393. Its gravity vertical may easily be constructed as in Fig. 443 [see (1) § 397].

The third span carries no load; hence its positive moment-area is zero, and the actual moment-area is composed solely of the two triangular negative moment-areas CDH and DHI , the moment-curve consisting of the single straight line HI .

The fourth span carries a uniform load $W^{IV} = w^{IV} l^{IV}$, and \therefore has a positive moment-area

$$(M.A.)_2^{IV} = \frac{1}{12} W^{IV} (l^{IV})^2 \quad . \quad . \quad . \quad (3)$$

as in eq. (1), acting through the middle of the span (gravity-vertical).

Since the fifth and last span carries no load, its positive moment-area is zero, the moment curve being the straight line JF , so that the actual moment-area is composed of the left-hand negative moment-area.

At F it is noticeable that the reaction or pressure of the support must be from above downward to prevent the beam from leaving the point F ; i.e., the beam must be "latched down," and the reaction is negative.

If the beam were built in at A (or F) the moment at that section would not be zero, hence the left (or right) neg. moment-area would not be zero in that span, as in our present figure. But in such a case the tangent of the elastic curve would have a *known direction* at A (or F) and the problem would still be determinate as will be seen.

$A' \dots F'$ gives an approximate idea (exaggerated) of the form of the elastic curve of the entire girder. A change in the loading on any span would affect the form of this curve throughout its whole length as well as of all the moment curves.

NOTE.—It is important to remark that any two of the triangular negative moment-areas which have a common base (hence lying in adjacent spans) are proportional to their altitude i.e., to the lengths of the spans in which they occur; thus the neg. mom.-areas (Fig. 446) GCH and DCH have a common base CH ,

$$\therefore \frac{(M.A.)_3''}{(M.A.)_1'''} = \frac{l''}{l'''} \dots \dots \dots (4)$$

(The notation explains itself; see figure.) It also follows, that the resultant of these two neg. moment-areas (if required in any construction; see § 400) acts in a vertical which divides the horizontal distance between their gravity verticals in the inverse ratio of the spans to which they belong [§ 21 and eq. (4) above].

Hence, since this horizontal distance is $\frac{1}{3}l'' + \frac{1}{3}l'''$ their resultant must act in a vertical F''' , whose distance from the gravity-vertical of GCH is $\frac{1}{3}l''$, and from that of CHD , $\frac{1}{3}l$.

399. Amount and Gravity-Vertical of the Positive Moment Area of One Span as Due to Any Loading.—Since we can not deal directly with a continuous load by graphics, but must subdivide it into a number of detached loads sufficiently numerous to give a close approximation, let us suppose that this has already been done if necessary, and that P_1 , P_2 , etc., are the detached loads resting in the span AB in question; see Fig. 447.

Since [by (1), § 397] the positive moment-area is the same as the total moment-area would be if this portion of the beam simply rested on the extremities of the span, not extending beyond them, we may use the construction in § 389 for finding it, remembering that in that paragraph the

oblique polygon in the lower part of Fig. 439 will serve as well as the (upper) one whose abutment-line is the beam itself, *as far as moments are concerned.*

Hence, Fig. 447, lay off the load-line LL' , take any pole O , with any convenient pole-distance H , and draw the equilibrium polygon FWG . After joining FG , $FWGF$ will be the positive moment-area required.

To find its gravity vertical, divide the span AB , or FG' , into from ten to twenty equal parts (each $=\Delta s$) and draw a

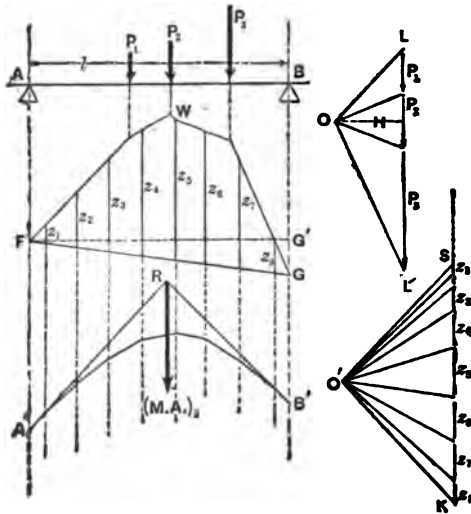

FIG. 447.

vertical through the middle of each. The lengths z_1, z_2 , etc., on these verticals, intercepted in the moment-area, are proportional to the corresponding strips of moment-area, each of width $=\Delta s$, and of an amount $=H z \Delta s$.

Form a load line, SK , of the successive z 's, and with any pole O' , draw the equilibrium polygon $A'B'$ (for the z -verticals). The intersection, R , of the extreme segments, is a point in the required gravity-vertical (§ 336).

The amount of the moment-area is $(M.A.)_2 = \Sigma [H z \Delta s]$

$$= H \cdot \Delta s \cdot \Sigma (z) = H \cdot \Delta s (z_1 + z_2 + z_3 + \dots)$$

For example, with the span $=l=120$ in., subdivided into twelve equal Δs 's, we have $\Delta s=10$ inches (of actual distance). If $H=4$ inches of paper and $SK=\Sigma(z)=10.2$ inches of paper, the force-scale being 80 lbs. to the inch, and the distance-scale 15 inches to the inch (1:15), we have

$$(M.A.)_z=[4 \times 80] \times 10 \times [10.2 \times 15]=489600. \text{ (sq. in.) (lbs.)}$$

400. Construction of the "False-Polygons" For All the Spans of a Given (Prismatic) Continuous Girder, Under Given Loading, and With Given Heights of Supports.—[See note in § 397 for meaning of "false-polygon".] Let us suppose that the given girder covers three unequal spans, Fig. 448, with supports at unequal heights, and that both extremities A and D are built-in, or "fixed," horizontally. To clear the ground for the present construction, we suppose that, from the given loading in each span, the positive moment-area of each span has been obtained in numerical form [so many (sq. in.) (lbs.) or (sq. in.) (tons)] and its gravity-vertical determined by § 398 or § 399; that the horizontal distances (i.e., the spans l' , l'' , and l''' and the distance between the above gravity-verticals and the supports) have been laid off on some convenient scale; that EI has been computed from the material and shape of section of the girder and expressed in the same units as the above moment-areas; that a convenient value for n has been selected (since $EI \div n$ is to be the pole distance of all the moment-area-diagrams), and that the vertical distances of B , C , and D , from the horizontal through A , have been laid off accordingly (see note in § 396).

In the figure (448) verticals are drawn through the points of support; also verticals dividing each span into thirds, since the unknown negative moment-areas (subscripts 1 and 3) act in the latter (§ 397); and the gravity-verticals of the known positive moment-areas. The verticals Y' , Y'' , V'' , and V''' , are to be constructed later.

The problem may now be stated as follows:

Given the positions of the supports, the value of EI and n ,

the fact that the girder is fixed horizontally at *A* and *D*, the heights of supports, the location of the gravity-verticals of all the positive and negative moment-areas, and the amounts of the positive moment-areas; it is required to find graphically the "false-polygon" in each span.

The "false-polygons," viz.: *A 123 B* for the first span (on the left), *B 123 C* for the second, etc., are drawn in the figure

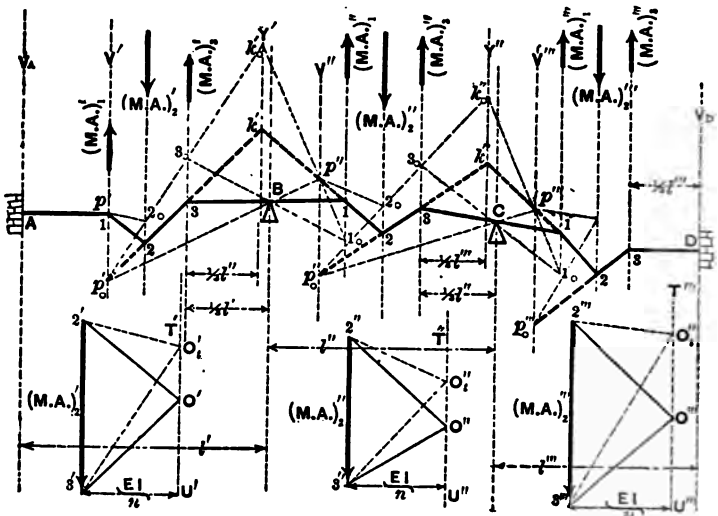

FIG. 448.

for the purpose of discussing their properties at the outset. Since *3B* and *B1* are both tangent to the elastic curve at *B*, they form a single straight line; similarly *C1* is but the prolongation of *3C*. Also *A1* and *3D* must be horizontal since the beam is built in horizontally at its extremities *A* and *D*.

That is, the three false polygons form a continuous equilibrium polygon *A...D*, in equilibrium under the "loads"

$$(M.A.)_1', (M.A.)_2', (M.A.)_3', \text{ etc.},$$

so that we might use a single mom.-area-diagram in connection with it, but for convenience the latter will be

drawn in portions, one under each span, with a pole distance $= \frac{EI}{n}$.

Of this polygon $A \dots D$, we have the two segments $A1$ and $3D$ already drawn, and know that it passes through the points B and C ; we shall next determine by construction other points (called "fixed points") p_0', p'', p_0'', p''' , and p_0''' in (the prolongations of) certain other segments.

To find the "fixed point" p_0' , where the segment 23 in the first span cuts the vertical V' , the gravity-vertical of $(M.A.)_1'$. The vertex p' , or 1, is already known, being the intersection of $A1$ with V' . Lay off $2'3' = (M.A.)_2'$ which is known, and take a trial pole O_1' with a pole-distance $EI+n$; join $O_1'2'$ and $O_1'3'$. Draw $1_0 \parallel$ to $2'O_1$ to determine 2_0 on the vertical $(M.A.)_2'$, then through 2_0 a line \parallel to $O_1'3'$ to cut V' in p_0' . The unknown segment 23 must cut V' in the same point; since all positions of O_1' on the vertical $T'U'$ will result in placing p_0' in this same point, and one of these positions must be the real pole O' (unknown). [This is easily proved in detail by two pairs of similar triangles].

To determine the "fixed-point" p'' , in the prolongation of segment 12 of second span. The prolongations of the segments 12 (of first span) and 12 (of second span) must meet in a point k in the (vertical) line of action of the resultant of $(M.A.)_2'$ and $(M.A.)_1''$ (§ 336). Although the amounts of $(M.A.)_2'$ and $(M.A.)_1''$ are unknown, still the vertical line of action of their resultant (by § 398, Note) is known to be Y' , a horizontal distance $\frac{l''}{3}$ to the right of $(M.A.)_2'$; hence Y' is easily drawn. Therefore, the unknown triangle $k'31$ has its three vertices on three known verticals, the side $k'3$ passes through the known point p_0' , and the side 13 through the known point B . Now by prolonging $p_0'2_0$ (or any line through p_0') to cut $(M.A.)_2'$ and Y' in 3_0 and k_0' , respectively, joining 3_0B and prolonging this line to cut $(M.A.)_1''$ in some point 1_0 , and then joining $k_0'1_0$, we have a triangle $k_0'3_01_0$ of which we can make a

statement precisely the same as that just made for $k' 3 1$

But if two triangles [as $k'31$ and $k_0' 3_0 1_0$] have their vertices on three parallel lines (or on three lines which meet in a point) the three intersections of their corresponding sides must lie on the same straight line [see reference to Chauvenet, § 378 *a*]. Of these intersections we have two, p_0' and B ; hence the third must lie at the intersection of the line $p_0' B$ (prolonged) with $k_0' 1_0$, and in this way the "fixed point" p'' , a point in $k'1$ and \therefore in the segment 12 (of second span) prolonged, is found. Draw a vertical through it and call it V'' .

The fixed point p_0'' (in prolongation of segment 23 of second span) lies in the vertical V'' and is found from p'' and the known value of $(M.A.)_2''$ precisely as p_0' was found from p' . That is, we lay off vertically $2'' 3'' = (M.A.)_2''$, and join $2''$ and $3''$ to O_1'' , which is any point at distance $EI \div \kappa$ to the right of $2''3''$. Through p'' draw a line \perp to $2'' O_1''$ to cut $(M.A.)_2''$ in $2_0''$, then $2_0 p_0'' \parallel$ to $O_1'' 3''$ to determine p_0'' on the vertical V'' .

The fixed points p''' and p_0''' in the third span lie in the prolongations of the segments 12 and 23, respectively, of that span, p''' being found from the points p_0'' and C and the verticals $(M.A.)_3''$, Y'' , and $(M.A.)_1'''$, in the same manner as p'' was determined with similar data, while p_0''' , in the same vertical V''' as p''' , depends on $(M.A.)_2'''$ and its gravity vertical as already illustrated; hence the detail need not be given; see figure.

In this way for any number of spans we proceed from span to span toward the right and determine the successive fixed points, until the points p and p_0 of the last span have been constructed, which are p''' and p_0''' in our present problem. Since p_0''' is a point in the segment 23 (prolonged) of the last span, we have only to join it with 3 in that span, a point already known, and the segment 23 is determined. Joining the intersection 2 with p''' we determine the next segment 21 and of course the vertex 1, which is then joined with C and prolonged to intersect $(M.A.)_3'''$ to fix the segment 1C3 and the point 3. Join

3 p_0'' , and proceed in a similar manner toward the left, until the whole equilibrium polygon (or series of "false polygons") is finally constructed; the last step being the joining of 2 with p' .

401. Treatment of Special Features of the Last Problem.—(1.) If the beam is *simply supported at A*, Fig. 448, instead of built-in, $(M. A.)_1'$ becomes zero, and the two segments $A1$ and 12 of that span form a single segment of unknown direction. Hence, the point A will take the place of p' , and the vertical V_A that of V' .

(2.) Similarly, if D , in the last span, is a simple support (beam not built in) $(M. A.)_3'''$ becomes zero, and the segments $D3$ and 32 form a single segment of unknown direction, so that after p_0''' has been found, we join p_0''' and D to determine the segment $D2$; i.e., in this last span, D takes the place of 3 of the previous article.

(3.) If the first span carries no load $(M. A.)_2'$ is zero, and the segments 12 and 23 will form a single segment 23 . Hence if the beam is built in at A , p_0' will coincide with the known point p' (i.e., 1), while if A is a simple support p and p' coincide with A , since, then, $(M. A.)_1'$ is zero and $A123$ is a single segment.

(4.) If the last span is unloaded (third span in Fig. 448), $(M. A.)_2'''$ is zero, 123 becomes a single segment, and hence p_0''' will coincide with p''' ; so that after p''' has been constructed it is to be directly joined to 3, if the beam is built in at D , and will thus determine the segment 13 ; or to D , if D is a simple support, (for then $(M. A.)_3'''$ is zero and the three segments 12 , 23 , and $3D$ form a single segment.)

(5.) If an intermediate span is unloaded (say the second span, Fig. 448) the positive mom.-area, $(M. A.)_2''$, is zero, 123 becomes a straight line, i.e. a single segment, and therefore p_0'' coincides with p'' ; hence, when p'' has been found we proceed as if it were p_0'' .

402. To Find the Negative Mom.-Areas, the Mom.-Curves, Shears, and Reactions of the Supports.—(1.) Having constructed the

false polygons according to the last two articles, the *negative moment-areas* of each span are then to be found by the note in § 397, Fig. 445, and expressed in numerical form.

[If the positive mom.-area of the span is zero the points 2' and 3' will coincide, Fig. 445, and in the case mentioned in (3), (or (4)), of § 401, if *A* (or *D*) were a simple support, in Fig. 448, the mom.-area-diagram of Fig. 445 would have but two rays.]

(2.) The *moments at the supports* (or "end-moments" of the respective spans) depending, as they do, directly on the negative mom.-areas, can now be computed as illustrated in (3) § 397. The fact that each "end-moment" may be obtained from *two* negative mom.-areas, separately, one in each adjacent span (except, of course at the extremities of the girder) forms a check on the accuracy of the work. The two values should agree within one or two per cent.

(3.) The "*moment-curve*" of each span or equilibrium polygon formed from a force-diagram whose load-line consists of the actual loads on the span laid off in proper order, can now be drawn, a convenient value for *H* having been selected (*the same H for all the spans*, that the moment-curves of successive spans may form a continuous line for the whole girder); since we may easily compute the proper moment ordinate at each support to represent the actual moment, then, for the *H* adopted, by (3) § 397. The moment-curve of each span, since we know its two extreme points and its pole-distance *H*, is then constructed by § 341.

(4.) *The shear.* Since the last construction involves drawing the special force-diagram for each span, with a ray corresponding to each part of the span between two consecutive loads, the *shear* at any section of the beam is easily found as being the length of the vertical projection of the "proper ray," interpreted by the force-scale of the force-diagram, as in §§ 389 and 390. With the shears as

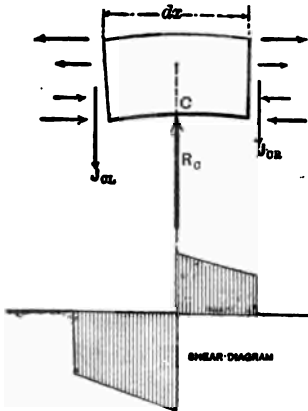

FIG. 449.

ordinates a shear-diagram may now be constructed, if desired, for each span. The directions of the shears should be carefully noted.

(5.) *Reactions of supports.* Let us consider "free" the small portion of the girder, at each point of support, included between two sections, one close to the support on each side, Fig. 449. Suppose it is the support C , and call the reaction, or pressure at that support R_c . Then, for vertical equilibrium, i.e., $\Sigma Y = 0$ (§ 36), we have

$$R_c = J_{CR} + J_{CL} \quad . \quad . \quad . \quad . \quad (5)$$

and, in general, the reaction at a support equals the (algebraic) sum of the two shears, one close to the support on the right, the other on the left. The meaning of the subscripts is evident. In applying this rule, however, a free body like that in Fig. 449 should always be drawn, or conceived; *for the two shears are not always in the same direction; hence the phrase "algebraic sum."*

At a terminal support, as A or F , Fig. 446, if the beam is not built in, the reaction is simply equal to the shear (since the beam does not overhang) just as in §§ 241 and 243. Fig. 446 presents the peculiarity that the reaction of the support F is *negative*, (as compared with R_c in Fig. 449); i.e., the support at F must be placed above the beam to prevent its rising (this might also be the case at C , or D , in Fig. 446, for certain relations between the loads).

403. Numerical Example of Preceding Methods.—As illustrating the constructions just given, it is required to investigate the case of a rolled wrought-iron "I-beam," [a 15-inch heavy beam of the N. J. Steel and Iron Co.,] extending over four supports at the same level, covering three

spans of 16, 20, and 14 feet respectively, and bearing a single load in each of the extreme spans, but a uniform load over the entire central span. As indicated thus :

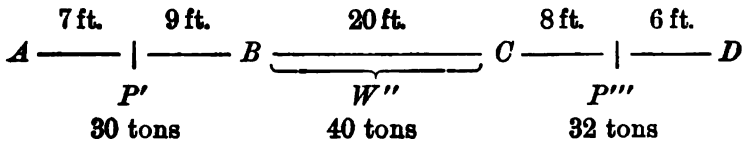

[This is a practical case where W'' is the weight of a brick wall, and P' and P''' are loads transmitted by columns from the upper floors of the building; A and D are simple supports, and the weight of the girder is neglected.]

The beam has a moment of inertia $I = 707$ biquad. inches, and the modulus of elasticity of the iron is $E = 25,000,000$ lbs. per sq. in., = 12,500 tons per sq. in.

Although with a prismatic continuous girder under given loading, *with supports at the same level*, it may easily be shown that the moments, shears, and reactions, to be obtained graphically, are the same for *all values of I* , so long as the elastic limit is not surpassed, still, on account of the necessity of its use in other problems (supports not on a level), we shall proceed as if the value of I were essential in this one.

Selecting the *inch* and *ton* as units for numerical work, we have

$EI = 12500 \times 707. = 8,837,500$ (sq. in.) (tons) while the respective positive mom.-areas, from eqs. (2) and (3) of § 398, are :

$$\begin{aligned}
 (M. A.)_2' &= \frac{1}{2} \times 30 \times 84 \times 108 = 136,080 \text{ (sq. in.) (tons)} \\
 (M. A.)_2'' &= \frac{1}{12} \times 40 \times 240^2 = 192,000 \text{ " " " } \\
 (M. A.)_2''' &= \frac{1}{2} \times 32 \times 96 \times 72 = 110,592 \text{ " " " }
 \end{aligned}$$

Adopting a scale of 60,000 (sq. in.) (tons) to the linear inch of paper, for mom.-area diagrams, we have for the above mom.-areas 2.27 in., 3.20 in., and 1.84 in., respectively, on the paper, for use in Fig. 448.

Having laid off the three spans on a scale of 60 inches to the inch of paper, with A , B , C , and D in the *same horizontal line*, we find by the construction of Fig. 443, that the gravity-vertical of $(M. A.)_2'$ lies 3.6 in. to the left of the middle in the first span, that of $(M. A.)_2'''$ 4.8 in. to the right of the middle of the third span; while that of $(M. A.)_2''$, of course, bisects the central span. Hence we draw these verticals; and also those of the unknown negative mom.-areas through the one-third points; remembering [§ 401, (1) and (2)] that $(M. A.)_1'$ and $(M. A.)_3'''$ are both zero in this case.

Since $EI = 8,837,500$ (sq. in.) (tons), it would require 147.29 in. to represent it, as pole-distance, on a scale of 60,000 (sq. in.) (tons) to the inch; hence let us take $n = 50$ for the degree of (vertical) exaggeration of the false polygons, since the corresponding pole-distance $\frac{EI}{n} = 2.94$ in.

of paper is a convenient length for use with the values of $(M. A.)_2'$, $(M. A.)_2''$, etc., above given.

Following the construction of Fig. 443, except that p' is at A , and p_0''' is to be joined to D (§ 401), (the student will do well to draft the problem for himself, using the prescribed scales,) and thus determining the false-polygons, we then construct and compute the neg. mom.-areas according to § 402 (1), and the note in § 397, obtaining the following results:

$(M. A.)_3'$, 1.43 in. of pap.,	=	85,800 (sq. in.) (tons)
$(M. A.)_1''$, 1.77 " " "	=	106,200 " " "
$(M. A.)_3''$, 1.68 " " "	=	100,800 " " "
$(M. A.)_1'''$, 1.17 " " "	=	70,200 " " "

The remaining results are best indicated by the aid of Fig. 450. Following the items of § 402, we find [(3) § 397] that the moment at B , using $(M. A.)_1''$, is

$$M_B = \frac{2 \times 106,200}{240 \text{ in.}} = 885 \text{ inch-tons.}$$

$$[\text{or, using } (M. A.)_3', M_B = \frac{2 \times 85,800}{192} = 893 \text{ in. tons.}]$$

$$\text{Similarly, } M_C = \frac{2 \times 100,800}{240} = 840 \text{ in. tons.}$$

[or, using $(M. A.)_1'''$, $M_C = 835.7 \text{ in. tons.}$]

Hence, taking means, we have, finally,

$$M_A = 0; M_B = 889 \text{ in. tons}; M_C = 837.8; M_D = 0.$$

Fig. 450 shows the actual mom.-areas and shear-diagrams, which are now to be constructed.

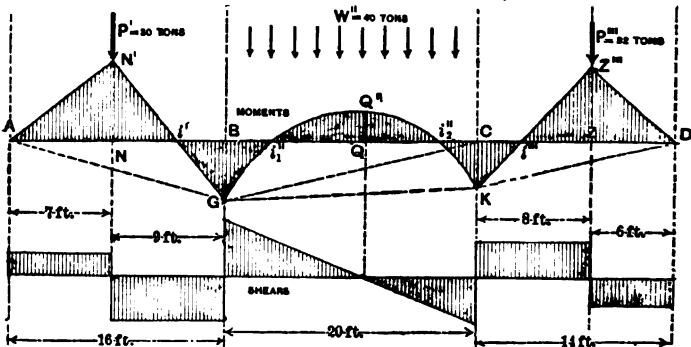

FIG. 450.

Selecting a value $H = 20$ tons for the pole-distance of the successive force-diagrams, (the scale of distances being 5 ft. (60 in.) to the inch we have [(3) § 397]

$20 \times \overline{BG} = M_B = 889 \text{ in.-tons} \therefore \overline{BG} = 44.4 \text{ in. of actual distance, or } 0.74 \text{ in. of paper; also } 20 \times \overline{CK} = M_C = 837.8 \text{ in.-tons} \therefore \overline{CK} = 41.89 \text{ in., or } 0.698 \text{ in. of paper.}$

Having thus found G and K , and divided BC into ten equal parts, applying four tons in the middle of each, we construct by § 341 an equilibrium polygon which shall pass through G and K and have 20 tons as a pole-distance. (We take a force-scale of 10 tons to the inch.) It will form a (succession of short tangents to a) parabola, and is the moment curve for span BC . Similarly, for the single

loads P' and P''' in the other two spans, we draw the equilibrium polygons $AN'G$ and $KZ'''D$, for the same H as before, and passing through A and G , and K and D , respectively.

Scaling the moment-ordinates NN' , QQ'' , and ZZ''' , reducing to actual distance and multiplying by H , we have for these local moment maxima, $M_N = 1008$, $M_Q = 336$, and $M_Z = 936$, in. tons.

Evidently the greatest moment is M_N and \therefore the stress in the outer fibre at N will be (§ 239)

$$p_N = \frac{M_N e}{J} = \frac{1008 \times 7\frac{1}{2}}{707} = 10.0 \text{ tons per sq. inch which is much}$$

too large. If we employ a 20-inch heavy beam, with $I = 1650$ biquad. in., the preceding moments will still be the same (*supports all at same level*) and we have

$$p_N = \frac{1008 \times 10}{1650} = 6.06 \text{ tons per sq. in.,}$$

or nearly 12,000 lbs. per sq. in., and is therefore safe (§ 183).

If three discontinuous beams were to be used, the 20-inch size of beam (heavy) would be much too weak, in each of the three spans, as may be easily shown; hence the economy of the continuous girder in such a case is readily perceived. It will be seen, however, that the cases of continuity and of discontinuity do not differ so much in the shear-diagrams as in the moment curves. By scaling the vertical projection of the proper rays in the special force diagrams (as in §§ 389 and 390) we obtain the shear for any section on AN , as J_{AR} (see Fig. 449 for notation) = 12.3 tons; on NB , $J_{BL} = 17.7$ tons; from B to C it varies uniformly from $J_{BR} = 20.3$ tons, through zero at Q , to $J_{CL} = 19.7$ tons of opposite sign. Also, for CZ , $J_{CR} = 18.6$ tons; and for ZD , $J_{DL} = 13.4$ tons. Hence, the reactions of the supports are as follows:

$$R_A = J_{AR} = 12.3 \text{ tons; } R_B = J_{BL} + J_{BR} = 38.0 \text{ tons.}$$

$$R_C = J_{CR} + J_{CL} = 38.3 \text{ tons; } R_D = J_{DL} = 13.4 \text{ tons.}$$

[In the shear-diagram, the shear-ordinates are laid off *below* the axis when the shear points down, the "free body" extending to the right of the section considered, (as J_{ct} in Fig. 449); and *above*, when the shear points upward for the same position of the free body.]

If we divide the max. shear, 20.3 tons by the area of the web, 13.75 sq. in., of the 20-inch heavy beam, (§256), we obtain 1.5 tons or 3000 lbs. per sq. in., which is < 4000 (§ 183). Notice the points of inflection, i' , i'' , etc., where M is zero.

Sufficient bearing surface should be provided at the supports.

A swing-bridge offers an interesting case of a continuous girder.

404. Continuous Girder of Variable Mom. of Inertia.—If I is variable and I_0 denote the mom. of inertia of some convenient standard section, then we may write $I = I_0 \div m$, when m denotes the number of times I_0 contains I . In a non-prismatic beam, m is different for different sections but is easily found, and will be considered given at each section.

In eq. (1) of § 391, then, we must put $I_0 \div m$ in place of I and thus write

$$\frac{d^2y}{dx^2} = \frac{[mMdx]}{EI_0} \dots \dots \dots (1)$$

and (pursuing the same reasoning as there given) may therefore say that *in a girder of variable section if each small vertical strip (Mdx) of the moment-area be multiplied by the value of m proper to that section, and these products (or "virtual mom.-area strips) considered as loads, the elastic curve is an equilibrium polygon for those loads with a pole distance = EL_0 .*

In modifying § 400 for a girder of variable section, then, besides taking $EL_0 \div n$ as pole distance, proceed as follows:

Construct the positive mom.-area for each span according to § 399; for each s of Fig. 447, substitute ms (each z

having in general its own m), and thus obtain the "virtual positive mom.-area," and its gravity vertical.

Similarly, there will be an unknown "virtual neg. mom.-area," not triangular, replacing each neg. mom.-area of § 400. Though it is not triangular, each of its ordinates equals the corresponding ordinate of the unknown triangular neg. mom.-area multiplied by the proper m , and its gravity-vertical (*which is independent of the amount of the unknown neg. mom.-area*) is found in advance by the process of Fig. 447, using, for z 's, a set of ordinates obtained thus: Draw any two straight lines AB and FB , Fig. 445, (for a left-hand trial neg. mom.-area; or FB and GF for a right-hand one) meeting in the end-vertical of the span, divide the span into ten or twenty equal spaces, draw a vertical through the middle of each, noting their intercepts between AB and FB . Add these intercepts and call the sum S . Multiply each intercept by the proper m , and with these new values as z 's construct their gravity vertical as in Fig. 447. Add these new intercepts, call the sum S_v , and denote the quotient $S \div S_v$ by β .

We substitute the three verticals mentioned, therefore, for the mom.-area verticals of § 400, and the "virtual pos. mom.-area" for the pos. mom.-area, in each span; proceed in other respects to construct the "false polygons" according to § 400. Then the result of applying the construction in the note § 397 will be the "virtual neg. mom.-areas," each of which is to be multiplied by the proper β to obtain the corresponding triangular neg. mom.-area, with which we then proceed, without further modifications in the process, according to (2), (3), etc. of § 402.

[The conception of these "virtual mom.-areas" is due to Prof. Eddy; see p. 36 of his "Researches in Graphical Statics," referred to in the preface of this work.]

405. Remarks.—It must be remembered that any unequal settling of the supports after the girder has been put in place, may cause considerable changes in the values of the moments, shears, etc., and thus cause the actual stresses to be quite different from those computed without taking

into account a possible change in the heights of the supports. See § 271.

For example, if some of the supports are of masonry, while others are the upper extremities of high iron or steel columns, the fluctuations of length in the latter due to changes of temperature will produce results of the nature indicated above.

If an open-work truss of homogeneous design from end to end (treated as a girder of constant moment of inertia, whose value may be formulated as in § 388,) is used as a continuous girder under moving loads, it will be subject to "reversal of stress" in some of its upper and lower horizontal members, i.e., the latter must be of a proper design to sustain both tension and compression, (according to the position of the moving loads,) and this may disturb the assumption of homogeneity of design. Still, if I is variable, § 404 can be used; but since the weight of the truss must be considered as part of the loading, several assumptions and approximations may be necessary before establishing satisfactory dimensions.

PART IV.

HYDRAULICS.

CHAPTER I.

DEFINITIONS—FLUID PRESSURE—HYDROSTATICS BEGUN.

406. A Perfect Fluid is a substance the particles of which are capable of moving upon each other with the greatest freedom, absolutely without friction, and are destitute of mutual attraction. In other words, the stress between any two contiguous portions of a perfect fluid is always one of *compression* and *normal* to the dividing surface at every point; i.e., *no shear* or tangential action can exist on any imaginary cutting plane.

Hence if a perfect fluid is contained in a vessel of rigid material the pressure experienced by the walls of the vessel is *normal to the surface of contact at all points*.

For the practical purposes of Engineering, water, alcohol, mercury, air, steam, and all gases may be treated as perfect fluids within certain limits of temperature.

407. Liquids and Gases.—A fluid a definite mass of which occupies a definite volume at a given temperature, and is incapable both of expanding into a larger volume and of being compressed into a smaller volume at that temperature, is called a **Liquid**, of which water, mercury, etc., are common examples; whereas a **Gas** is a fluid a mass of which is capable of almost indefinite expansion or compression, according as the space within the confining vessel is made larger or smaller, and always tends to fill the vessel, which must therefore be closed in every direction to prevent its escape.

Liquids are sometimes called *inelastic* fluids, and gases *elastic* fluids.

408. Remarks.—Though practically we may treat all liquids as incompressible, experiment shows them to be compressible to a slight extent. Thus, a cubic inch of water under a pressure of 15 lbs. on each of its six faces loses only fifty millionths (0.000050) of its original volume, while remaining at the same temperature; if the temperature be sufficiently raised, however, its bulk will remain unchanged (provided the initial temperature is over 40° Fahr.). Conversely, by heating a liquid in a rigid vessel completely filled by it, a great bursting pressure may be produced. The slight cohesion existing between the particles of most liquids is too insignificant to be considered in the present connection.

The property of indefinite expansion, on the part of gases, by which a confined mass of gas can continue to fill a confined space which is progressively enlarging, and exert pressure against its walls, is satisfactorily explained by the "Kinetic Theory of Gases," according to which the gaseous particles are perfectly elastic and in continual motion, impinging against each other and the confining walls. Nevertheless, for practical purposes, we may consider a gas as a continuous substance.

Although by the abstraction of heat, or the application of great pressure, or both, all known gases may be reduced to liquids (some being even solidified); and although by converse processes (imparting heat and diminishing the pressure) liquids may be transformed into gases, the range of temperature and pressure in all problems to be considered in this work is supposed kept within such limits that no extreme changes of state, of this character, take place. A gas approaching the point of liquefaction is called a **Vapor**.

Between the solid and the liquid state we find all grades of intermediate conditions of matter. For example, some substances are described as soft and plastic solids, as soft putty, moist earth, pitch, fresh mortar, etc.; and others as viscous and sluggish liquids, as molasses and glycerine. In sufficient bulk,

however, the latter may still be considered as perfect fluids. Even water is slightly viscous.

409. Heaviness of Fluids.—The weight of a cubic unit of a homogeneous fluid will be called its *heaviness*, or rate of weight (see § 7), and is a measure of its density. Denoting it by γ , and the volume of a definite portion of the fluid by V , we have, for the weight of that portion,

$$G = V\gamma. \dots \dots \dots (1)$$

This, like the great majority of equations used or derived in this work, is of *homogeneous form* (§ 6), i.e., admits of any system of units. E.g., in the metre-kilogram-second system, if γ is given in kilos. per cubic metre, V must be expressed in cubic metres, and G will be obtained in kilos.; and similarly in any other system. The quality of γ , $= G \div V$, is evidently one dimension of force divided by three dimensions of length.

In the following table, in the case of gases, the temperature and pressure are mentioned at which they have the given heaviness. since under other conditions the heaviness would be different; in the case of liquids, however, for ordinary purposes the effect of a change of temperature may be neglected (within certain limits).

HEAVINESS OF VARIOUS FLUIDS.*

[In ft. lb. sec. system; γ = weight in lbs. of a cubic foot.]

Liquids.	Gases { At temp. of melting ice; and 14.7 lbs. per sq. in. tension.
Fresh water, $\gamma =$ 62.5	Atmospheric Air.....0.08076
Sea water.....64.0	Oxygen.....0.0892
Mercury.....848.7	Nitrogen.....0.0786
Alcohol.....49.8	Hydrogen.....0.0056
Crude Petroleum, about.....55.0	Illuminating } from.....0.0800
(N.B.—A cubic inch of water weighs 0.036024 lbs.; and a cubic foot 1000 av. oz.)	Gas, } to.....0.0400
	Natural Gas, about.....0.0500

* See Trautwine's Civ. Engineer's Pocket Book for an extended table—p. 380, edition of 1835.

For use in problems where needed, values for the heaviness of pure fresh water are given in the following table (from Rossetti) for temperatures ranging from freezing to boiling; as also the relative density, that at the temperature of maximum density, 39°.3 Fahr. being taken as unity. The temperatures are Fahr., and γ is in lbs. per cubic foot.

Temp.	Rel. Dens.	γ .	Temp.	Rel. Dens.	γ .	Temp.	Rel. Dens.	γ .
32°	.99967	62.416	60°	.99907	62.366	140°	.96838	61.386
35°	.99996	62.421	70°	.99802	62.300	150°	.96043	61.208
39°.3	1.00000	62.424	80°	.99669	62.217	160°	.97729	61.006
40°	.99999	62.423	90°	.99510	62.118	170°	.97897	60.799
43°	.99997	62.422	100°	.99318	61.998	180°	.97059	60.586
45°	.99992	62.419	110°	.99105	61.865	190°	.96701	60.365
50°	.99975	62.408	120°	.98870	61.719	200°	.96333	60.135
55°	.99946	62.390	130°	.98608	61.555	212°	.95865	59.843

From D. K. Clark's "Manual."	} for temp. =	230°	250°	270°	290°	296°	333°	366°	390°
		γ =	59.4	58.7	58.2	57.6	57.3	56.1	55.3

EXAMPLE 1. What is the heaviness of a gas, 432 cub. in. of which weigh 0.368 ounces? Use ft.-lb.-sec. system.

$$432 \text{ cub. in.} = \frac{1}{4} \text{ cub. ft. and } 0.368 \text{ oz.} = 0.023 \text{ lbs.}$$

$$\therefore \gamma = \frac{G}{V} = \frac{0.023}{\frac{1}{4}} = 0.092 \text{ lbs. per cub. foot.}$$

EXAMPLE 2. Required the weight of a right prism of mercury of 1 sq. inch section and 30 inches altitude.

$V = 30 \times 1 = 30 \text{ cub. in.} = \frac{30}{1728} \text{ cub. feet; while from the table, } \gamma \text{ for mercury} = 848.7 \text{ lbs. per cub. ft.}$

$$\therefore \text{its weight} = G = V\gamma = \frac{30}{1728} \times 848.7 = 14.73 \text{ lbs.}$$

410. Definitions.—By *Hydraulics* we understand the mechanics of fluids as utilized in Engineering. It may be divided into

Hydrostatics, treating of fluids at rest; and

Hydrodynamics (or *Hydrokinetics*), which deals with fluids in motion. (The name *Pneumatics* is sometimes used to cover both the statics and dynamics of gaseous fluids.)

[Rankine's nomenclature has been adopted in the present work. Some recent writers use the term *Hydromechanics* for mechanics of fluids, subdividing it into *Hydrostatics* and *Hydrokinetics*, as above; they also use the term Dynamics to embrace both of the two divisions called Statics and Dynamics by Rankine, which by them are called Statics and Kinetics respectively. Though unusual, perhaps, the term Hydraulics is here used to cover the applied Mechanics of Gases as well as of Liquids.]

Before treating separately of liquids and gases, a few paragraphs will be presented applicable to both kinds of fluids.

411. **Pressure per Unit Area, or Intensity of Pressure.**—As in § 180 in dealing with solids, so here with fluids we indicate the pressure per unit area between two contiguous portions of fluid, or between a fluid and the wall of the containing vessel, by p , so that if dP is the total pressure on a small area dF , we have

$$p = \frac{dP}{dF} \dots \dots \dots (1)$$

as the pressure per unit area, or intensity of pressure (often, though ambiguously, called the *tension* in speaking of a gas) on the small surface dF . If pressure of the *same intensity* exists over a finite plane surface of area = F , the total pressure on that surface is

or
$$\left. \begin{aligned} P &= \int p dF = p \int dF = Fp, \\ p &= \frac{P}{F}. \end{aligned} \right\} \dots \dots \dots (2)$$

(N.B.—For brevity the single word “pressure” will sometimes be used, instead of intensity of pressure, where no ambiguity can arise.) Thus, it is found that, under ordinary conditions at the sea level, the atmosphere exerts a normal pressure (normal, because fluid pressure) on all surfaces, of an intensity of about $p = 14.7$ lbs. per sq. inch (= 2116. lbs. per sq. ft.). This intensity of pressure is called *one atmosphere*. For ex

ample, the total atmospheric pressure on a surface of 100 sq. in. is [inch, lb., sec.]

$$P = Fp = 100 \times 14.7 = 1470 \text{ lbs. } (= 0.735 \text{ tons.})$$

The quality of p is evidently one dimension of force divided by two dimensions of length.

412. Hydrostatic Pressure; per Unit Area, in the Interior of a Fluid at Rest.—In a body of fluid of uniform heaviness, at rest, it is required to find the mutual pressure per unit area between the portions of fluid on opposite sides of any imaginary cutting plane. As customary, we shall consider portions of the fluid as free bodies, by supplying the forces exerted on them by all contiguous portions (of fluid or vessel wall), also those of the earth (their weights), and then apply the conditions of equilibrium.

First, cutting plane horizontal.—Fig. 451 shows a body of

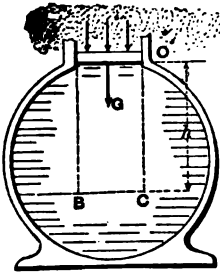

FIG. 451.

homogeneous fluid confined in a rigid vessel closed at the top with a small airtight but frictionless piston (a horizontal disk) of weight = G and exposed to atmospheric pressure (= p_a per unit area) on its upper face. Let the area of piston-face be = F . Then for the equilibrium of the piston the total pressure between its under surface and the fluid at O must be

$$P = G + Fp_a,$$

and hence the intensity of this pressure is

$$p_o = \frac{G}{F} + p_a. \quad \dots \dots (1)$$

It is now required to find the intensity, p , of fluid pressure between the portions of fluid contiguous to the horizontal cutting plane BC at a vertical distance = h vertically below the piston O . In Fig. 452 we have as a free body the right parallelo-

piped OBC of Fig. 451 with vertical sides (two \parallel to paper and four \perp to it). The pressures acting on its six faces are normal to them respectively, and the weight of the prism is $= \text{vol.} \times \gamma = Fh\gamma$, supposing γ to have the same value at all parts of the column (which is practically true for any height of liquid and for a small height of gas). Since the prism is in equilibrium under the forces shown in the figure, and would still be so were it to become rigid, we may put (§36) Σ (vert. comps.) $= 0$ and hence obtain

$$Fp - Fp_0 - Fh\gamma = 0. \dots (2)$$

(In the figure the pressures on the vertical faces \parallel to paper have no vertical components, and hence are not drawn.) From (2) we have

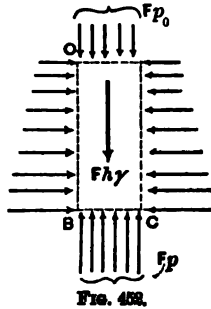

$$p = p_0 + h\gamma. \dots (3)$$

($h\gamma$, being the weight of a column of homogeneous fluid of unity cross-section and height h , would be the total pressure on the base of such a column, if at rest and with no pressure on the upper base, and hence might be called *intensity due to weight*.)

Secondly, cutting plane oblique.—Fig. 453. Consider free an infinitely small right triangular prism bcd , whose bases are

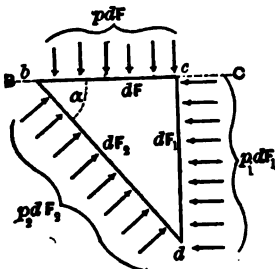

FIG. 453.

\parallel to the paper, while the three side faces (rectangles), having areas $= dF$, dF_1 , and dF_2 , are respectively horizontal, vertical, and oblique; let angle $cbd = \alpha$. The surface bc is a portion of the plane BC of Fig. 452. Given p ($=$ intensity of pressure on dF) and α , required p_2 , the intensity of pressure on the oblique face bd , of area dF_2 .

[N. B.—The prism is taken very small in order that the intensity of pressure may be considered constant over any one face; and also that the weight of the prism may be neglected, since it involves the volume (three dimen-

sions) of the prism, while the total face pressures involve only two, and is hence a differential of a higher order.]

From Σ (*vert. comps.*) = 0 we shall have

$$p_1 dF_1 \cos \alpha - p dF = 0; \text{ but } dF \div dF_1 = \cos \alpha;$$

$$\therefore p_1 = p, \dots \dots \dots (4)$$

which is independent of the angle α .

Hence, *the intensity of fluid pressure at a given point is the same on all imaginary cutting planes containing the point.* This is the most important property of a fluid, and is true whether the liquid is at rest or has *any kind of motion*; for, in case of rectilinear accelerated motion, *e.g.*, although the sum of the force-components in the direction of the acceleration does not in general = 0, but = mass \times acc., still, the mass of the body in question is = *weight* \div *g*, and therefore the term mass \times acc. is a differential of a higher order than the other terms of the equation, and hence the same result follows as when there is no motion (or uniform rectilinear motion).

413. The Intensity of Pressure is Equal at all Points of any Horizontal Plane in a body of homogeneous fluid at rest. If we consider a right prism of the fluid in Fig. 451, of small vertical thickness, its axis lying in any horizontal plane *BC*, its bases will be vertical and of equal area *dF*. The pressures on its sides, being normal to them, and hence to the axis, have no components \parallel to the axis. The weight of the prism also has no horizontal component. Hence from Σ (*hor. comps. \parallel to axis*) = 0, we have, p_1 and p_2 being the pressure-intensities at the two bases,

$$p_1 dF - p_2 dF = 0; \therefore p_1 = p_2, \dots \dots \dots (1)$$

which proves the statement at the head of this article.

It is now plain, from this and the preceding article, that the pressure-intensity p at any point in a homogeneous fluid at rest is equal to that at any higher point, plus the weight

($h\gamma$) of a column of the fluid of section unity and of altitude (h) = vertical distance between the points.

i.e.,
$$p = p_0 + h\gamma, \dots \dots \dots (2)$$

whether they are in the same vertical or not, and whatever be the shape of the containing vessel (or pipes), provided the fluid is continuous between the two points; for, Fig. 454, by considering a series of small prisms, alternately vertical and horizontal, *obcde*, we know that

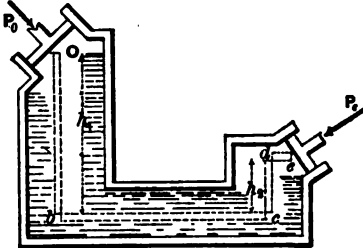

FIG. 454.

$$p_b = p_0 + h_1\gamma; \quad p_o = p_b;$$

$$p_a = p_o - h_2\gamma; \quad \text{and } p_e = p_a;$$

hence, finally, by addition we have

$$p_e = p_0 + h\gamma$$

(in which $h = h_1 - h_2$).

If, therefore, upon a small piston at *o*, of area = F_0 , a force P_0 be exerted, and an inelastic fluid (liquid) completely fills the vessel, then, for equilibrium, the force to be exerted upon the piston at *e*, viz., P_e , is thus computed: For equilibrium of fluid $p_e = p_0 + h\gamma$; and for equil. of piston *o*, $p_0 = P_0 \div F_0$; also, $p_e = P_e \div F_e$;

$$\therefore P_e = \frac{F_e}{F_0} P_0 + F_e h\gamma. \dots \dots \dots (3)$$

From (3) we learn that if the pistons are at the same level ($h = 0$) the total pressures on their inner faces are *directly proportional to their areas*.

If the fluid is gaseous (2) and (3) are practically correct if h is not > 100 feet (for, gas being compressible, the lower strata are generally more dense than the upper), but in (3) the pistons must be fixed, and P_0 and P_e refer solely to the interior pressures.

Again, if h is small or p , very great, the term $h\gamma$ may be omitted altogether in eqs. (2) and (3) (especially with gases, since for them γ (heaviness) is usually small), and we then have, from (2),

$$p = p_0; \dots \dots \dots (4)$$

being the algebraic form of the statement: *A body of fluid at rest transmits pressure with equal intensity in every direction and to all of its parts.* [Principle of "Equal Transmission of Pressure."]

414. Moving Pistons.—If the fluid in Fig. 454 is *inelastic* and the vessel walls rigid, the motion of one piston (o) through a distance s_1 causes the other to move through a distance s_2 determined by the relation $F_1 s_1 = F_2 s_2$ (since the volumes described by them must be equal, as liquids are incompressible); but on account of the inertia of the liquid, and friction on the vessel walls, equations (2) and (3) no longer hold exactly, still are approximately true if the motion is very slow and the vessel short, as with the cylinder of a water-pressure engine.

But if the fluid is compressible and elastic (gases and vapors; steam, or air) and hence of small density, the effect of inertia and friction is not appreciable in short wide vessels like the cylinders of steam- and air-engines, and those of air-compressors; and eqs. (2) and (3) still hold, practically, even with high piston-speeds. For example, in the space AB ,

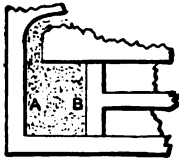

FIG. 455.

Fig. 455, between the piston and cylinder-head of a steam-engine (piston moving toward the right) the intensity of pressure, p , of the steam against the moving piston B is practically equal to that against the cylinder-head

A at the same instant.

415. An Important Distinction between gases and liquids (i.e., between elastic and inelastic fluids) consists in this:

A liquid can exert pressure against the walls of the containing vessel only by its weight, or (when confined on all sides) by transmitted pressure coming from without (due to piston pressure, atmospheric pressure, etc.); whereas—

A gas, confined, as it must be, on all sides to prevent diffusion, exerts pressure on the vessel not only by its weight, but by its elasticity or tendency to expand. If pressure from without is also applied, the gas is compressed and exerts a still greater pressure on the vessel walls.

416. Component, of Pressure, in a Given Direction.—Let $ABCD$, whose area = dF , be a small element of a surface, plane or curved, and p the intensity of fluid pressure upon this element, then the total pressure upon it is pdF , and is of course normal to it. Let $A'B'CD$ be the projection of the element dF upon a plane CDM making an angle α with the element, and let it be required to find the value of the component of pdF in a direction normal to this last plane (the other component being understood to be \parallel to the same plane). We shall have

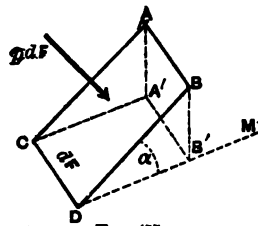

FIG. 455.

$$\text{Compon. of } pdF \perp \text{ to } CDM = pdF \cos \alpha = p(dF \cdot \cos \alpha). \quad (1)$$

But $dF \cdot \cos \alpha = \text{area } A'B'CD$, the projection of dF upon the plane CDM .

$$\therefore \text{Compon. } \perp \text{ to plane } CDM = p \times (\text{project. of } dF \text{ on } CDM);$$

i.e., the component of fluid pressure (on an element of a surface) in a given direction (the other component being \perp to the first) is found by multiplying the intensity of the pressure by the area of the projection of the element upon a plane \perp to the given direction.

It is seen, as an example of this, that if the fluid pressures on the elements of the inner surface of one hemisphere of a hollow sphere containing a gas are resolved into components \perp and \parallel to the plane of the circular base of the hemisphere, the sum of the former components simply = $\pi r^2 p$, where r is the radius of the sphere, and p the intensity of the fluid pressure; for, from the foregoing, the sum of these components is just the same as the total pressure would be, having an intensity p ,

on a great circle of the sphere, the area, πr^2 , of this circle being the sum of the areas of the projections, upon this circle as a base, of all the elements of the hemispherical surface. (Weight of fluid neglected.)

A similar statement may be made as to the pressures on the inner curved surface of a right cylinder.

417. Non-planar Pistons.—From the foregoing it follows that the sum of the components \parallel to the piston-rod, of the fluid pressures upon the piston at *A*, Fig. 457, is just the same as at *B*, if the cylinders are of equal size and the steam, or air, is at the same tension. For the sum of the projections of all the elements of the curved surface of *A* upon a plane \perp to the piston-rod is always $= \pi r^2 =$ area of section of cylinder-bore.

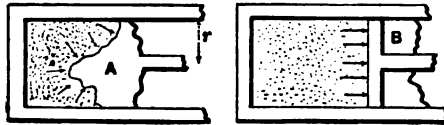

FIG. 457.

If the surface of *A* is symmetrical about the axis of the cylinder the other components (i.e., those \perp to the piston-rod) will neutralize each other. If the line of intersection of that surface with the surface of the cylinder is not symmetrical about the axis of the cylinder, the piston may be pressed laterally against the cylinder-wall, but the thrust along the rod or “*working force*” (§ 128) is the same (except for friction induced by the lateral pressure), in all instances, as if the surface were plane and \perp to piston-rod.

418. Bramah, or Hydraulic, Press.—This is a familiar instance of the principle of transmission of fluid pressure. Fig. 458. Let the small piston at *O* have a diameter $d = 1$ inch $= \frac{1}{12}$ ft., while the plunger *E*, or large piston, has a diameter $d' = AB = CD = 15$ in. $= \frac{1}{4}$ ft. The lever *MN* weighs $G_1 = 3$ lbs., and a weight $G = 40$ lbs. is hung at *M*. The lever-arms of these forces about the fulcrum *N* are given in the figure. The apparatus being full of water (oil is often used), the fluid pressure *P*, against the small piston is found by putting

$\Sigma(\text{moms. about } N) = 0$ for the equilibrium of the lever;
whence [ft., lb., sec.]

$$P_0 \times 1 - 40 \times 3 - 3 \times 2 = 0. \quad \therefore P_0 = 126 \text{ lbs.}$$

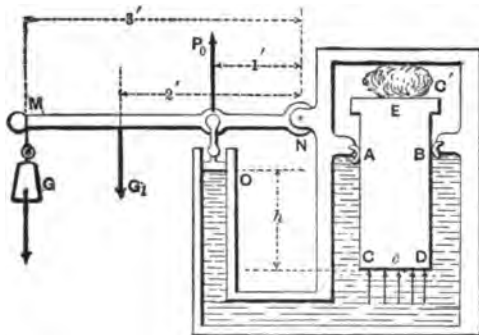

FIG. 458.

But, denoting atmospheric pressure by p_a , and that of the water against the piston by p_0 (per unit area), we may also write

$$P_0 = F_0 p_0 - F_0 p_a = \frac{1}{4} \pi d^2 (p_0 - p_a).$$

Solving for p_0 , we have, putting $p_a = 14.7 \times 144$ lbs. per sq. ft.,

$$p_0 = \left[126 \div \frac{\pi}{4} \left(\frac{1}{2} \right)^2 \right] + 14.7 \times 144 = 25236 \text{ lbs. per sq. ft.}$$

Hence at e the press. per unit area, from § 409, and (2), § 413, is

$$p_e = p_0 + h\gamma = 25236 + 3 \times 62.5 = 25423 \text{ lbs. per sq. ft.}$$

= 175.6 lbs. per sq. inch or 11.9 atmospheres, and the total upward pressure at e on base of plunger is

$$P = F_e p_e = \pi \frac{d^2}{4} p_e = \frac{1}{4} \pi \left(\frac{1}{2} \right)^2 \times 25423 = 31194 \text{ lbs.,}$$

or almost 16 tons (of 2000 lbs. each). The compressive force upon the block or bale, C , = P less the weight of the plunger and total atmos. pressure on a circle of 15 in. diameter.

419. The Dividing Surface of Two Fluids (which do not mix) in Contact, and at Rest, is a Horizontal Plane.—For, Fig. 459, sup-

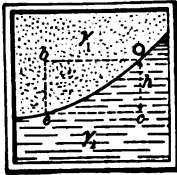

FIG. 459.

posing any two points e and O of this surface to be at different levels (the pressure at O being p_o , that at e p_e , and the heavinesses of the two fluids γ_1 and γ_2 , respectively), we would have, from a consideration of the two elementary prisms eb and bO (vertical and horizontal), the relation

$$p_e = p_o + h\gamma_2;$$

while from the prisms ec and cO , the relation

$$p_e = p_o + h\gamma_1.$$

These equations are conflicting, hence the above supposition is absurd. Therefore the proposition is true.

For stable equilibrium, evidently, the heavier fluid must occupy the lowest position in the vessel, and if there are several fluids (which do not mix), they will arrange themselves vertically, in the order of their densities, the heaviest at the bottom, Fig. 460. On account of the property called *diffusion* the particles of two gases placed in contact soon intermingle and form a uniform mixture. This fact gives strong support to the "Kinetic Theory of Gases" (§ 408).

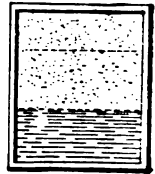

FIG. 460.

420. Free Surface of a Liquid at Rest.—The surface (of a liquid) not in contact with the walls of the containing vessel

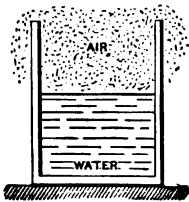

FIG. 461.

is called a *free surface*, and is necessarily horizontal (from § 419) when the liquid is at rest. Fig. 461. (A gas, from its tendency to indefinite expansion, is incapable of having a free surface.) This is true even if the space above the liquid is vacuum, for if the surface were inclined or curved, points in the body of the liquid and in the same horizontal plane would have different heights (or "heads") of liquid

between them and the surface, producing different intensities of pressure in the plane, which is contrary to § 413.

When large bodies of liquid like the ocean are considered, gravity can no longer be regarded as acting in parallel lines; consequently the free surface of the liquid is curved, being \perp to the direction of (apparent) gravity at all points. For ordinary engineering purposes (except in Geodesy) the free surface of water at rest is a horizontal plane.

421. Two Liquids (which do not mix) at Rest in a Bent Tube open at Both Ends to the Air, Fig. 460; water and mercury, for instance. Let their heavinesses be γ_1 and γ_2 , respectively. The pressure at e may be written (§ 413) either

$$p_e = p_0 + h_1 \gamma_1 \dots (1)$$

or

$$p_e = p_0 + h_2 \gamma_2 \dots (2)$$

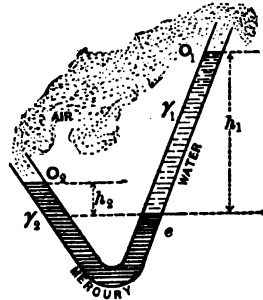

FIG. 462.

according as we refer it to the water column or the mercury column and their respective free surfaces where the pressure $p_0 = p_0 = p_a = \text{atmos. press.}$

e is the surface of contact of the two liquids. Hence we have

$$p_a + h_1 \gamma_1 = p_a + h_2 \gamma_2; \text{ i.e., } h_1 : h_2 :: \gamma_2 : \gamma_1 \dots (3)$$

i.e., the heights of the free surfaces of the two liquids above the surface of contact are inversely proportional to their respective heavinesses.

EXAMPLE.—If the pressure at $e = 2$ atmospheres (§ 396) we shall have from (1) (inch-lb.-sec. system of units)

$$h_2 \gamma_2 = p_e - p_a = 2 \times 14.7 - 14.7 = 14.7 \text{ lbs. per sq. inch.}$$

$$\therefore h_2 \text{ must} = 14.7 \div [848.7 \div 1728] = 30 \text{ inches}$$

(since, for mercury, $\gamma_2 = 848.7$ lbs. per cub. ft.). Hence, from (3),

$$h_1 = \frac{h_2 \gamma_2}{\gamma_1} = \frac{30 \times [848.7 \div 1728]}{62.5 \div 1728} = 408 \text{ inches} = 34 \text{ feet.}$$

i.e., for equilibrium, and that p_o may = 2 atmospheres, h_2 and h_1 (of mercury and water) must be 30 in. and 34 feet respectively.

422. City Water-pipes.—If h = vertical distance of a point B of a water-pipe below the free surface of reservoir, and the water be at rest, the pressure on the inner surface of the pipe at B (per unit of area) is

$$p = p_o + h\gamma; \text{ and here } p_o = p_a = \text{atmos. press.}$$

EXAMPLE.—If h = 200 ft. (using the inch, lb., and second)

$$p = 14.7 + [200 \times 12][62.5 \div 1728] = 101.5 \text{ lbs. per sq. in.}$$

The term $h\gamma$, alone, = 86.8 lbs. per sq. inch, is spoken of as the *hydrostatic pressure* due to 200 feet height, or “**Head,**” of water. (See Trautwine’s Pocket Book for a table of hydrostatic pressures for various depths.)

If, however, the water is *flowing* through the pipe, the pressure against the interior wall becomes less (a problem of Hydrodynamics to be treated subsequently), while if that motion is suddenly checked, the pressure becomes momentarily much greater than the hydrostatic. This shock is called “**water-ram**” and “**water-hammer,**” and may be as great as 200 to 300 lbs. per sq. inch.

423. Barometers and Manometers for Fluid Pressure.—If a tube, closed at one end, is filled with water, and the other ex-

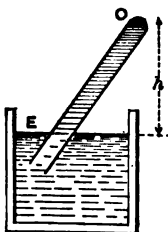

FIG. 463.

tremity is temporarily stopped and afterwards opened under water, the closed end being then a (vertical) height = h above the surface of the water, it is required to find the intensity, p_o , of fluid pressure at the top of the tube, supposing it to remain filled with water. Fig. 463. At E inside the tube the pressure is 14.7 lbs. per sq. inch, the same as that outside at the same level (§ 413); hence, from $p_E = p_o$

$$+ h\gamma,$$

$$p_o = p_E - h\gamma. (1)'$$

EXAMPLE.—Let $h = 10$ feet (with inch-lb.-sec. system); then

$$p_0 = 14.7 - 120 \times [62.5 \div 1728] = 10.4 \text{ lbs. per sq. inch,}$$

or about $\frac{2}{3}$ of an atmosphere. If now we inquire the value of h to make $p_0 =$ zero, we put $p_0 - h\gamma = 0$ and obtain $h = 408$ inches, = 34 ft., which is called *the height of the water-barometer*. Hence, Fig. 463a, ordinary atmospheric pressure will not sustain a column of water higher than 34 feet. If mercury is used instead of water the height supported by one atmosphere is

$$b = 14.7 \div [848.7 \div 1728] = 30 \text{ inches,}$$

= 76 centims. (about), and the tube is of more manageable proportions than with water, aside from the advantage that no vapor of mercury above the liquid at ordinary temperatures. [In fact, the water-barometer height $b = 34$ feet has only a theoretical existence since at ordinary temperatures (40° to 80° Fahr.) vapor of water would form above the column and depress it by from 0.30 to 1.09 ft.] Such an apparatus is called a *Barometer*, and is used not only for measuring the varying tension of the atmosphere (from 14.5 to 15 lbs. per sq. inch, according to the weather and height above sea-level), but also that of any body of gas. Thus, Fig.

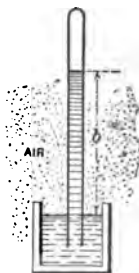

FIG. 463a.

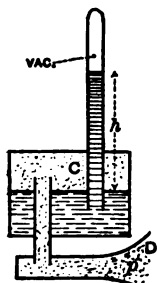

FIG. 464.

464, the gas in D is put in communication with the space above the mercury in the cistern at C ; and we have $p = h\gamma$, where $\gamma =$ heav. of mercury, and p is the pressure on the liquid in the cistern. For delicate measurements an attached thermometer is also used, as the heaviness γ varies slightly with the temperature.

If the vertical distance CD is small, the tension in C is considered the same as in D .

For gas-tensions greater than one atmosphere, the tube may be left open at the top, forming an *open ma-*

nometer, Fig. 465. In this case, the tension of the gas above the mercury in the cistern is

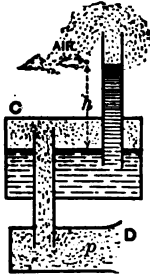

FIG. 465.

$$p = (h + b)\gamma, \dots \dots \dots (1)$$

in which b is the height of mercury (about 30 in.) to which the tension of the atmosphere above the mercury column is equivalent.

EXAMPLE.—If $h = 51$ inches, Fig. 465, we have (ft., lb., sec.)

$$p = [4.25 \text{ ft.} + 2.5 \text{ ft.}] 848.7 = 5728 \text{ lbs. per sq. foot} \\ = 39.7 \text{ lbs. per sq. inch} = 2.7 \text{ atmospheres.}$$

Another form of the open manometer consists of a U tube, Fig. 464, the atmosphere having access to one branch, the gas to be examined, to the other, while the mercury lies in the curve. As before, we have

$$p = (h + b)\gamma = h\gamma + p_a, \dots (2)$$

where $p_a =$ atmos. tension, and b as above. The tension of a gas is sometimes spoken of as measured by so many *inches of mercury*. For example, a tension of 22.05

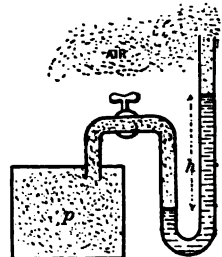

FIG. 464.

lbs. per sq. inch ($1\frac{1}{2}$ atmos.) is measured by 45 inches of mercury in a vacuum manometer (i.e., a common barometer), Fig. 464. With the open manometer this tension ($1\frac{1}{2}$ atmos.) would be indicated by 15 inches of actual mercury, Figs. 465 and 466. An ordinary steam-gauge indicates the *excess* of tension over one atmosphere; thus “40 lbs. of steam” implies a tension of $40 + 14.7 = 54.7$ lbs. per sq. in.

The *Bourdon* steam-gauge in common use consists of a curved elastic metal tube of flattened or elliptical section (with the long axis \perp to the plane of the tube), and has one end fixed. The movement of the other end, which is free and

closed, by proper mechanical connection gives motion to the pointer of a dial. This movement is caused by any change of tension in the steam or gas admitted, through the fixed end, to the interior of the tube. As the tension increases the elliptical section becomes less flat, i.e., more nearly circular, causing the two ends of the tube to separate more widely, i.e., the free end moves away from the fixed end; and *vice versa*.

Such gauges, however, are not always reliable. They are graduated by comparison with mercury manometers; and should be tested from time to time in the same way.*

424. Tension of Illuminating Gas.—This is often spoken of as measured by *inches of water* (from 1 to 3 inches usually). Strictly it should be stated that this water-height measures the *excess* of its tension over that of the atmosphere. Thus, in Fig. 466, water being used instead of mercury, $h =$ say 2 inches, while $b = 408$ inches.

This *difference* of tension may be largely affected by a change in the barometer due to the weather, or by a difference in altitude, as the following example will illustrate:

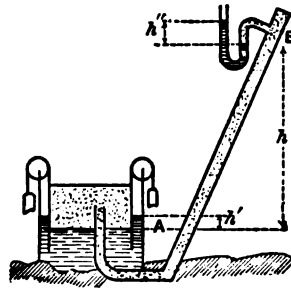

FIG. 467.

EXAMPLE.—Supposing the gas at rest, and the tension at the gasometer *A*, Fig. 467, to be “two inches of water,” required the water-column h'' (in open tube) that the gas will support in the pipe at *B*, 120 feet (vertically) above the gasometer. Let the temperature be freezing (nearly), and the outside air at a tension of 14.7 lbs. per sq. inch; the heaviness of the gas at this temperature being 0.036 lbs. per cubic foot. For the small difference of 120 ft. we may treat both the atmosphere and the gas as liquids, that is, of constant density throughout the vertical column, and therefore apply the principles of § 413; with the following result:

The tension of the outside air at *B*, supposed to be at the same temperature as at *A*, will sustain a water-column less than the 408 inches at *A* by an amount corresponding to the

* Of late years gauges have come into use constructed of boxes with corrugated sides of thin metal like the aneroid barometer. Motion of the sides, under varying internal fluid pressure, causes movement of a pointer on a dial.

120 feet of air between, of the heaviness .0807 lbs. per cub. ft. 120 feet of air weighing .0807 lbs. per cub. ft. will balance 0.154 ft. of water weighing 62.5 lbs. per cubic ft., i.e., 1.85 inches of water. Now the tension of the gas at *B* is also less than its tension at *A*, but the difference is not so great as with the outside air, for the 120 ft. of gas is lighter than the 120 ft. of air. Since 120 ft. of gas weighing 0.036 lbs. per cubic ft. will balance 0.0691 ft., or 0.83 inches, of water, therefore the difference between the tensions of the two fluids at *B* is greater than at *A* by $(1.85 - 0.83 =) 1.02$ inches; or, at *B* the total difference is $2.00 + 1.02 = 3.02$ inches.

Hence if a small aperture is made in the pipe at *B* the gas will flow out with greater velocity than at *A*. At Ithaca, N. Y., where the University buildings are 400 ft. above the gas-works, this phenomenon is very marked.

When the difference of level is great the decrease of tension as we proceed upward in the atmosphere, even with constant temperature, does not follow the simple law of § 413; see § 477.

For velocity of flow of gases through orifices, see § 548, etc.

425. Safety-valves.—Fig. 468. Required the proper weight *G* to be hung at the extremity of the horizontal lever *AB*,

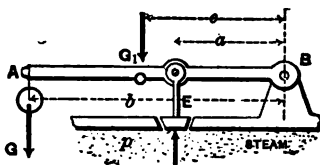

Fig. 468.

with fulcrum at *B*, that the flat disk-valve *E* shall not be forced upward by the steam pressure, *p*' , until the latter reaches a given value = *p*. Let the weight of the arm be *G*₁, its centre of gravity being at *C*, a distance = *c*

from *B*; the other horizontal distances are marked in the figure.

Suppose the valve on the point of rising; then the forces acting on the lever are the fulcrum-reaction at *B*, the weights *G* and *G*₁, and the two fluid-pressures on the disk, viz.: *Fp*_a (atmospheric) downward, and *Fp* (steam) upward. Hence, from $\Sigma(\text{moms. } B) = 0$,

$$Gb + G_1c + Fp_a a - Fp a = 0. \quad . . . (1)$$

Solving, we have

$$G = \frac{a}{b} F(p - p_a) - G, \frac{c}{b} \dots \dots \dots (2)$$

EXAMPLE.—With $a = 2$ inches, $b = 2$ feet, $c = 1$ foot $G_1 = 4$ lbs., $p = 6$ atmos., and diam. of disk = 1 inch; with the foot and pound,

$$G = \frac{2}{24} \cdot \frac{\pi}{4} \left(\frac{1}{12}\right)^2 [6 \times 14.7 \times 144 - 1 \times 14.7 \times 144] - 4 \times \frac{1}{2}$$

$$\therefore G = 2.81 \text{ lbs.}$$

[Notice the cancelling of the 144; for $F(p - p_a)$ is *pounds*, being one dimension of force, if the pound is selected as the unit of force, whether the inch or foot is used in both factors.] Hence when the steam pressure has risen to 6 atmos. (= 88.2 lbs. per square inch) (corresponding to 73.5 lbs. per sq. in. by steam-gauge) the valve will open if $G = 2.81$ lbs., or be on the point of opening.

426. Proper Thickness of Thin Hollow Cylinders (i.e., Pipes and Tubes) to Resist Bursting by Fluid Pressure.

CASE I. *Stresses in the cross-section due to End Pressure;*

Fig. 469.—Let AB be the circular cap closing the end of a cylindrical tube containing fluid at a tension = p . Let r = internal radius of the tube or pipe. Then considering the cap free, neglecting its weight, we have three sets of || forces in equilibrium in the figure, viz.: the internal fluid pressure = $\pi r^2 p$; the external fluid pressure = $\pi r^2 p_a$; while the total stress (tensile) on the small ring, whose area now exposed is $2\pi r t$ (nearly), is = $2\pi r t p$, where t is the thickness of the pipe, and p , the tensile stress per unit area induced by the end-pressures (fluid).

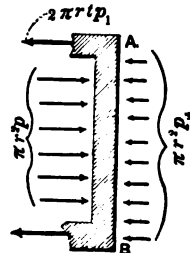

FIG. 469.

For equilibrium, therefore, we may put $\Sigma(\text{hor. comps.}) = 0$;
i.e.,

$$\pi r^2 p - \pi r^2 p_a - 2\pi r t p_1 = 0;$$

$$\therefore p_1 = \frac{r(p - p_a)}{2t} \dots \dots \dots (1)$$

(Strictly, the two circular areas sustaining the fluid pressures are different in area, but to consider them equal occasions but a small error.)

Eq. (1) also gives the tension in the central section of a *thin hollow sphere*, under bursting pressure.

CASE II. *Stresses in the longitudinal section of pipe, due to radial fluid pressures.**—Consider free the half (semi-circular)

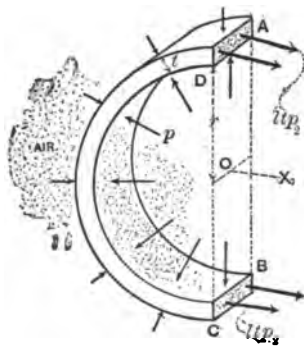

FIG. 470.

of any length l of the pipe, between two cross-sections. Take an axis X (as in Fig. 470) \perp to the longitudinal section which has been made. Let p_1 denote the tensile stress (per unit area) produced in the narrow rectangles exposed at A and B (those in the half-ring edges, having no X components, are not drawn in the figure). On the internal curved surface the fluid pressure is considered of equal intensity

$= p$ at all points (practically true even with liquids, if $2r$ is small compared with the head of water producing p). The fluid pressure on any dF or elementary area of the internal curved surface is $= pdF$. Its X component (see § 416) is obtained by multiplying p by the projection of dF on the vertical plane ABC , and since p is the same for all the dF 's of the curved surface, the sum of all the X components of the internal fluid pressures must $= p$ multiplied by the area of rectangle $ABCD$, $= 2rlp$; and similarly the X components of the

* Analytically this problem is identical with that of the smooth cord on a smooth cylinder, § 169, and is seen to give the same result.

external atmos. pressures = $2rlp_a$ (nearly). The tensile stresses (\parallel to X) are equal to $2lt p_i$; hence for equilibrium, $\Sigma X = 0$ gives

$$2lt p_i - 2rl p + 2rl p_a = 0;$$

$$\therefore p_i = \frac{r(p - p_a)}{t} \dots \dots \dots (2)$$

This tensile stress, called *hoop tension*, p_i , opposing rupture by longitudinal tearing, is seen to be double the tensile stress p_i induced, under the same circumstances, on the annular cross-section in Case I. Hence eq. (2), and not eq. (1), should be used to determine a safe value for the thickness of metal, t , or any other one unknown quantity involved in the equation.

For safety against rupture, we must put $p_i = T'$, a safe tensile stress per unit area for the material of the pipe or tube (see §§ 195 and 203);

$$\therefore t = \frac{r(p - p_a)}{T'} \dots \dots \dots (3)$$

(For a *thin hollow sphere*, t may be computed from eq. (1); that is, need be only half as great as with the cylinder, other things being equal.)

EXAMPLE.—A pipe of twenty inches internal diameter is to contain water at rest under a head of 340 feet; required the proper thickness, if of cast-iron.

340 feet of water measures 10 atmospheres, so that the internal fluid pressure is 11 atmospheres; but the external pressure p_a being one atmos., we must write (inch, lb., sec.)

$$(p - p_a) = 10 \times 14.7 = 147.0 \text{ lbs. per sq. in., and } r = 10 \text{ in.,}$$

while (§ 203) we may put $T' = \frac{1}{2}$ of 9000 = 4500 lbs. per sq. in.; whence

$$t = \frac{10 \times 147}{4500} = 0.326 \text{ inches.}$$

But to insure safety in handling pipes and imperviousness to the water, a somewhat greater thickness is adopted in practice than given by the above theory.

Thus, Weisbach recommends (as proved experimentally also) for

$$\text{Not homogen.} \left\{ \begin{array}{l} \text{Pipes of sheet iron, } t = [0.00172 rA + 0.12] \text{ inches;} \\ \text{“ “ cast “ } t = [0.00476 rA + 0.34] \text{ “} \\ \text{“ “ copper } t = [0.00296 rA + 0.16] \text{ “} \\ \text{“ “ lead } t = [0.01014 rA + 0.21] \text{ “} \\ \text{“ “ zinc } t = [0.00484 rA + 0.16] \text{ “} \end{array} \right.$$

in which t = thickness in inches, r = radius in inches, and A = excess of internal over external fluid pressure (i.e., $p - p_a$) expressed in *atmospheres*.

For instance, for the example just given, we should have (cast-iron)

$$t = .00476 \times 10 \times 10 + 0.34 = 0.816 \text{ inches.}$$

If the pipe is subject to “water-ram” (§ 422) the strength should be much greater. To provide against “water-ram,” Mr. J. T. Fanning, on p. 453 of his “Hydraulic and Water-supply Engineering,” advises adding 230 feet to the static head in computing the thickness of cast-iron pipes.

For *thick hollow cylinders* see Rankine’s Applied Mechanics, p. 290, and Cotterill’s Applied Mechanics, p. 403.

427. Collapsing of Tubes under Fluid Pressure. (Cylindrical boiler-flues, for example.)—If the external exceeds the internal fluid pressure, and the thickness of metal is small compared with the diameter, the slightest deformation of the tube or pipe gives the external pressure greater capability to produce a further change of form, and hence possibly a final collapse; just as with long columns (§ 303) a slight bending gives great advantage to the terminal forces. Hence the theory of § 426 is inapplicable. According to Sir Wm. Fairbairn’s experiments (1858) a thin wrought-iron cylindrical (circular) tube will not collapse until the excess of external over internal pressure is

$$p(\text{in lbs. per sq. in.}) = 9672000 \frac{t^3}{ld^2} \quad . \quad . \quad (1) \quad . \quad . \quad (\text{not homog.})$$

(t , l , and d must all be expressed in the same linear unit.) Here t = thickness of the wall of the tube, d its diameter, and l its length; the ends being understood to be so supported as to preclude a local collapse.

EXAMPLE.—With $l = 10 \text{ ft.} = 120 \text{ inches}$, $d = 4 \text{ in.}$, and $t = \frac{1}{8} \text{ inch}$, we have

$$p = 9672000 \left[\frac{1}{100} \div (120 \times 4) \right] = 201.5 \text{ lbs. per sq. inch.}$$

For safety, $\frac{1}{2}$ of this, viz. 40 lbs. per sq. inch, should not be exceeded; e.g., with 14.7 lbs. internal and 54.7 lbs. external.

[NOTE.—For simplicity the power of the thickness used in eq. (1) above has been given as 2.00. In the original formula it is 2.19, and then all dimensions must be expressed in *inches*. A discussion of the experiments of Mr. Fairbairn will be found in a paper read by Prof. Unwin before the Institute of Civ. Engineers (Proceedings, vol. xlv.). See also Prof. Unwin's "Machine Design," p. 66. It is contended by some that in the actual conditions of service, boiler-flues are subjected to such serious straining actions due to unequal expansion of the connecting parts as to render the above formula quite unreliable, thus requiring a large allowance in its application.]

CHAPTER II.

HYDROSTATICS (*Continued*)—PRESSURE OF LIQUIDS IN TANKS AND RESERVOIRS.

428. Body of Liquid in Motion, but in Relative Equilibrium.—By relative equilibrium it is meant that the particles are not changing their relative positions, i.e., are not moving among each other. On account of this relative equilibrium the following problems are placed in the present chapter, instead of under the head of *Hydrodynamics*, where they strictly belong. As *relative equilibrium* is an essential property of rigid bodies, we may apply the equations of motion of rigid bodies to bodies of liquid in relative equilibrium.

CASE I. *All the particles moving in parallel right lines with equal velocities; at any given instant (i.e., a motion of translation.)*—If the common velocity is *constant* we have a *uniform translation*, and all the forces acting on any one particle are balanced, as if it were not moving at all (according to Newton's Laws, § 54); hence the relations of internal pressure, free surface, etc., are the same as if the liquid were at rest. Thus, Fig. 471, if the liquid in the moving tank is at rest

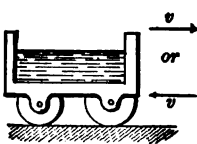

FIG. 471.

relatively to the tank at a given instant, with *its free surface horizontal*, and the motion of the tank be one of translation with a uniform velocity, the liquid will remain in this condition of relative rest, as the motion proceeds.

But if the velocity of the tank is *accelerated* with a *constant acceleration* $= \bar{p}$ (this symbol must not be confused with p for pressure), the free surface will begin to oscillate, and finally come to relative equilibrium at some angle α with the horizontal, which is thus found, when the motion is horizontal. See Fig. 472, in which the position and value of α are the same, whether the motion is uniformly accelerated from left to right

or uniformly retarded from right to left. Let O be the lowest point of the free surface, and Ob a small prism of the liquid with its axis horizontal, and of length = x ; nb is a vertical prism of length = z , and extending from the extremity of Ob to the free surface. The pressure at both O and n is p_a = atmos. pres. Let the area of cross-section of both prisms be = dF .

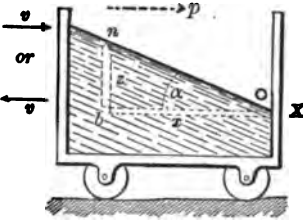

FIG. 472.

Now since Ob is being accelerated in direction X (horizont.), the difference between the forces on its two ends, i.e., its ΣX , must = its mass \times accel. (§ 109).

$$\therefore p_b dF - p_a dF = [x dF \cdot \gamma \div g] \bar{p} \dots (1)$$

(γ = heaviness of liquid; p_b = press. at b); and since the vertical prism nb has no vertical acceleration, the Σ (vert. compns.) for it must = 0.

$$\therefore p_b dF - p_a dF - z dF \cdot \gamma = 0 \dots (2)$$

From (1) and (2),

$$\frac{x\gamma}{g} \cdot \bar{p} = z\gamma; \therefore \frac{z}{x} = \frac{\bar{p}}{g} \dots (3)$$

Hence On is a right line, and therefore

$$\tan \alpha, \text{ or } \frac{z}{x}, = \frac{\bar{p}}{g} \dots (4)$$

[Another, and perhaps more direct, method of deriving this result is to consider free a small particle of the liquid lying in the surface. The forces acting on this particle are two: the first its weight = dG ; and the second the resultant action of its immediate neighbor-particles. Now this latter force (pointing obliquely upward) must be normal to the free surface of the liquid, and therefore must make the unknown angle α with the vertical. Since the particle has at this instant a rectilinear accelerated motion in a horizontal direction, the resultant of the two forces mentioned must be horizontal and have a value = mass \times acceleration. That is, the diagonal formed on the two

forces must be horizontal and have the value mentioned, = $(dG \div g)\bar{p}$; while from the nature of the figure (let the student make the diagram for himself) it must also = $dG \tan \alpha$.

$$\therefore dG \tan \alpha = \frac{dG}{g} \cdot \bar{p}; \text{ or, } \tan \alpha = \frac{\bar{p}}{g} \quad \dots \dots \text{ Q. E. D.]}$$

If the translation were *vertical*, and the acceleration *upward* [i.e., if the vessel had a uniformly accelerated upward motion or a uniformly retarded downward motion], the free surface would be horizontal, but the pressure at a depth = h below the surface instead of $p = p_a + h\gamma$ would be obtained as follows: Considering free a small vertical prism of height = h with upper base in the free surface, and putting $\Sigma(\text{vert. comps.}) = \text{mass} \times \text{acceleration}$, we have

$$dF \cdot p - dF \cdot p_a - hdF \cdot \gamma = \frac{hdF \cdot \gamma}{g} \cdot \bar{p};$$

$$\therefore p = p_a + h\gamma \left[\frac{g + \bar{p}}{g} \right] \dots \dots \dots (5)$$

If the acceleration is downward (not the velocity necessarily) we make \bar{p} negative in (5). If the vessel falls freely, $\bar{p} = -g$ and $\therefore p = p_a$, in all parts of the liquid.

Query: Suppose \bar{p} downward and $> g$.

CASE II. Uniform Rotation about a Vertical Axis.—If the narrow vessel in Fig. 473, open at top and containing a liquid,

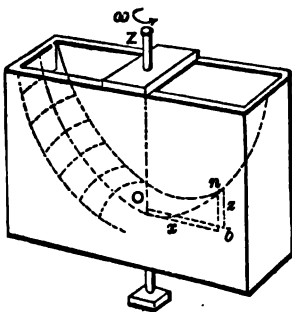

FIG. 473.

be kept rotating at a uniform angular velocity ω (see § 110) about a vertical axis Z , the liquid after some oscillations will be brought (by friction) to relative equilibrium (rotating about Z , as if rigid). Required the form of the free surface (evidently a surface of revolution) at each point of which we know $p = p_a$.

Let O be the intersection of the axis Z with the surface, and n any point in the surface; b being

a point vertically under n and in same horizontal plane as O . Every point of the small right prism nb (of altitude = z and sectional area dF) is describing a horizontal circle about Z , and has therefore no vertical acceleration. Hence for this prism, free, we have $\Sigma Z = 0$; i.e.,

$$dF \cdot p_b - dF \cdot p_a - zdF \cdot \gamma = 0. \dots (1)$$

Now the horizontal right prism Ob (call the direction $O\dots b$, X) is rotating uniformly about a vertical axis through one extremity, as if it were a rigid body. Hence the forces acting on it must be equivalent to a single horizontal force, $-\omega^2 M \bar{\rho}$, (§122a,) coinciding in direction with X . [M = mass of prism = its weight $\div g$, and $\bar{\rho}$ = distance of its centre of gravity from O ; here $\bar{\rho} = \frac{1}{2}x = \frac{1}{2}$ length of prism]. Hence the ΣX of the forces acting on the prism Ob must = $-\omega^2 \frac{xdF}{g} \gamma \frac{1}{2}x$.

But the forces acting on the two ends of this prism are their own X components, while the lateral pressures and the weights of its particles have no X compon. ;

$$\therefore dF \cdot p_a - dF \cdot p_b = \frac{-\omega^2 x^2 dF \cdot \gamma}{2g}. \dots (2)$$

From (1) and (2) we have

$$z = \frac{(\omega x)^2}{2g} = \frac{v^2}{2g}; \dots (3)$$

where $v = \omega x$ = linear velocity of the point n in its circular path.

[As in Case I, we may obtain the same result by considering a single surface-particle free, and would derive for the resultant force acting upon it the value $dG \tan \alpha$ in a horizontal direction and intersecting the axis of rotation. But here α is different for particles at different distances from the axis, $\tan \alpha$ being the $\frac{dz}{dx}$ of the curve On . As the particle is moving uniformly in a circle the resultant force must point toward the

centre of the circle, i.e., horizontally, and have a value $\frac{dG}{g} \cdot \frac{v^2}{x}$, where x is the radius of the circle [§ 74, eq. (5)];

$$\therefore dG \tan \alpha = \frac{dG (\omega x)^2}{g x}; \text{ or } \tan \alpha = \frac{dz}{dx} = \frac{\omega^2 x}{g};$$

$$\therefore \int_0^z dz = \frac{\omega^2}{g} \int_0^x x dx; \text{ or, } z = \frac{\omega^2}{g} \cdot \frac{x^2}{2}. \quad \text{Q. E. D.}$$

Hence any vertical section of the free surface through the axis of rotation Z is a parabola, with its axis vertical and vertex at O ; i.e., the free surface is a *paraboloid of revolution*, with Z as its axis. Since ωx is the linear velocity v of the point b in its circular path, $z =$ "height due to velocity" v [§ 52].

EXAMPLE.—If the vessel in Fig. 473 makes 100 revol. per minute, required the ordinate z at a horizontal distance of $x = 4$ inches from the axis (ft.-lb.-sec. system). The angular velocity $\omega = [2\pi 100 \div 60]$ radians per sec. [N. B.—A *radian* = the angular space of which 3.1415926 . . . make a half-revol., or angle of 180°]. With $x = \frac{1}{3}$ ft. and $g = 32.2$,

$$z = \frac{\omega^2 x^2}{2g} = \left(\frac{10\pi}{3}\right)^2 \left(\frac{1}{3}\right)^2 \frac{1}{64.4} = 0.188 \text{ ft.} = 2\frac{1}{4} \text{ inches,}$$

and the pressure at b (Fig. 471) is (now use inch, lb., sec.)

$$p_b = p_a + zy = 14.7 + 2\frac{1}{4} \times \frac{62.5}{1728} = 14.781 \text{ lbs. per sq. in.}$$

Prof. Mendelejeff of Russia has recently utilized the fact announced as the result of this problem, for forming perfectly true paraboloidal surfaces of plaster of Paris, to receive by galvanic process a deposit of metal, and thus produce specula of exact figure for reflecting telescopes. The vessel containing the liquid plaster is kept rotating about a vertical axis at the proper uniform speed, and the plaster assumes the desired shape before solidifying. A fusible alloy, melted, may also be placed in the vessel, instead of liquid plaster.

REMARK.—If the vessel is quite full and closed on top, except at O' where it communicates by a stationary pipe with a reservoir, Fig. 474, the free surface cannot be formed, but the pressure at any point in the water is just the same during uniform rotation, as if a free surface were formed with vertex at O ;

$$\text{i.e., } p_b = p_a + (h_0 + z)\gamma. \quad (4)$$

See figure for h_0 and z . (In subsequent paragraphs of this chapter the liquid will be at rest.)

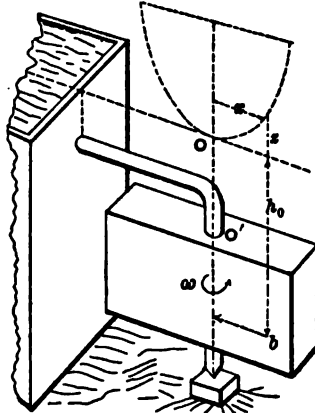

FIG. 474.

428a. Pressure on the Bottom of a Vessel containing Liquid at

Rest.—If the bottom of the vessel is plane and horizontal, the intensity of pressure upon it is the same at all points, being

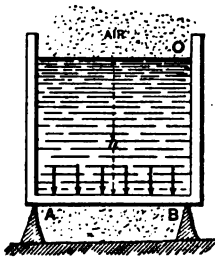

FIG. 475.

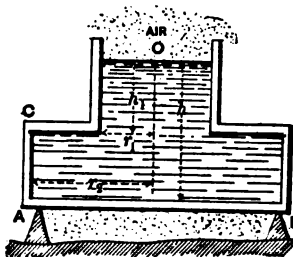

FIG. 476.

$p = p_a + h\gamma$ (Figs. 475 and 476), and the pressures on the elements of the surface form a set of parallel (vertical) forces. This is true even if the side of the vessel overhangs, Fig. 476, the resultant fluid pressure on the bottom in both cases being

$$P = Fp - Fp_a = Fh\gamma. \quad (1)$$

(Atmospheric pressure is supposed to act under the bottom.) It is further evident that if the bottom is a rigid homogeneous plate and has no support at its edges, it may be supported at a

single point (Fig. 477), which in this case (horizontal plate) is its centre of gravity. This point is called the **Centre of Pressure**, or the point of application of the resultant of all the fluid pressures acting on the plate. The present case is such that these pressures reduce to a single resultant, but this is not always practicable.

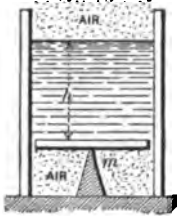

FIG. 477.

EXAMPLE.—In Fig. 476 (cylindrical vessel containing water), given $h = 20$ ft., $h_1 = 15$ ft., $r_1 = 2$ ft., $r_2 = 4$ ft., required the pressure on the bottom, the vertical tension in the cylindrical wall CA , and the hoop tension (§ 426) at C . (Ft., lb., sec.) Press. on bottom = $Fh\gamma = \pi r_2^2 h\gamma = \pi 16 \times 20 \times 62.5 = 62857$ lbs.; while the upward pull on $CA =$

$$(\pi r_2^2 - \pi r_1^2) h_1 \gamma = \pi (16 - 4) 15 \times 62.5 = 35357 \text{ lbs.}$$

If the vertical wall is $t = \frac{1}{16}$ inch thick at C this tension will be borne by a ring-shaped cross-section of area = $2\pi r_2 t$ (nearly) = $2\pi 48 \times \frac{1}{16} = 30.17$ sq. inches, giving $(35357 \div 30.17) =$ about 1200 lbs. per sq. inch tensile stress (vertical).

The *hoop* tension at C is horizontal and is

$$p'' = r_2 (p - p_a) \div t \text{ (see § 426), where } p = p_a + h_1 \gamma ;$$

$$\therefore p'' = \frac{48 \times 15 \times 12 \times (62.5 \div 1728)}{\frac{1}{16}} = 3125 \text{ lbs. per sq. in.}$$

(using the inch and pound).

429. Centre of Pressure.—In subsequent work in this chapter, since the atmosphere has access both to the free surface of liquid and to the outside of the vessel walls, and p_a would cancel out in finding the resultant fluid pressure on any elementary area dF of those walls, we shall write :

The resultant fluid pressure on any dF of the vessel wall is normal to its surface and is $dP = pdF = z\gamma dF$, in which z is the vertical distance of the element below the free surface of the liquid (i.e., $z =$ the "head of water"). If the surface pressed on is plane, these elementary pressures form a system of parallel forces, and may be replaced by a single resultant

(if the plate is rigid) which will equal their sum, and whose point of application, called the **Centre of Pressure**, may be located by the equations of § 22, put into calculus form.

If the surface is *curved* the elementary pressures form a system of forces in space, and hence (§ 38) cannot in general be reduced to a single resultant, but to *two*, the point of application of one of which is arbitrary (viz., the arbitrary origin, § 38).

Of course, the object of replacing a set of fluid pressures by a single resultant is for convenience in examining the equilibrium, or stability, of a rigid body the forces acting on which include these fluid pressures. As to their effect in *distorting* the rigid body, the fluid pressures must be considered in their true positions (see example in § 264), and cannot be replaced by a resultant.

430. Resultant Liquid Pressure on a Plane Surface forming Part of a Vessel Wall. Co-ordinates of the Centre of Pressure.—

Fig. 478. Let AB be a portion (of any shape) of a plane surface at any angle with the horizontal, sustaining liquid pressure. Prolong the plane of AB till it intersects the free surface of the liquid. Take this intersection as an axis Y , O being any point on Y . The axis X , \perp to Y , lies in the given plane. Let $\alpha =$ angle between the plane and the free surface. Then x and y are the co-ordinates of any elementary

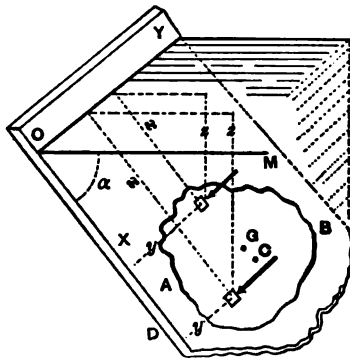

FIG. 478.

area dF of the surface, referred to X and Y . $z =$ the "head of water," below the free surface, of any dF . The pressures are parallel.

The normal pressure on any $dF = \gamma z dF$; hence the sum of these, = their resultant,

$$= P, = \gamma \int z dF = F \bar{z} \gamma; \dots \dots (1)$$

in which \bar{z} = the "mean z ," i.e., the z of the centre of gravity G of the plane figure AB , and F = total area of AB [$F\bar{z} = \int z dF$, from eq. (4), § 23]. γ = heaviness of liquid (see § 409).

That is, the total liquid pressure on a plane figure is equal to the weight of an imaginary prism of the liquid having a base = area of the given figure and an altitude = vertical depth of the centre of gravity of the figure below the surface of the liquid. For example, if the figure is a rectangle with one base (length = b) in the surface, and lying in a vertical plane,

$$P = bh \cdot \frac{1}{2}h\gamma = \frac{1}{2}bh^2\gamma.$$

Evidently, if the altitude be increased, P varies as its square.

From (1) it is evident that the total pressure does not depend on the horizontal extent of the water in the reservoir.

Now let x_0 and y_0 denote the co-ordinates, in plane YOX , of the centre of pressure, C , or point of application of the resultant pressure P , and apply the principle that the sum of the moments of each of several parallel forces, about an axis γ to them, is equal to the moment of their resultant about the same axis [§ 22]. First taking OY as an axis of moments, and then OX , we have

$$Px_0 = \int_A^B (zydF)x, \text{ and } Py_0 = \int_A^B (zydF)y. \quad (2)$$

But $P = F\bar{z}\gamma = F\bar{x}(\sin \alpha)\gamma$, and the z of any $dF = x \sin \alpha$. Hence eqs. (2) become (after cancelling the constant, $\gamma \sin \alpha$)

$$x_0 = \frac{\int x^2 dF}{F\bar{x}} = \frac{I_Y}{F\bar{x}}, \text{ and } y_0 = \frac{\int xy dF}{F\bar{x}}; \quad \dots \quad (3)$$

in which I_Y = the "mom. of inertia" of the plane figure referred to Y (see § 85). [N. B.—The centre of pressure as thus found is identical with the centre of oscillation (§ 117) and the centre of percussion [§ 113] of a thin homogeneous plate, referred to axes X and Y , Y being the axis of suspension.]

Evidently, if the plane figure is vertical $\alpha = 90^\circ$, $x = z$ for

all dF 's, and $\bar{x} = \bar{x}$. It is also noteworthy that the position of the centre of pressure is independent of α .

NOTE.—Since the pressures on the equal dF 's lying in any horizontal strip of the plane figure form a set of equal parallel forces *equally spaced along the strip*, and are therefore equivalent to their sum applied in the *middle* of the strip, it follows that for rectangles and triangles with horizontal bases, the centre of pressure must lie on the straight line on which the middles of all horizontal strips are situated.

431. **Centre of Pressure of Rectangles and Triangles with Bases Horizontal.**—Since all the dF 's of one horizontal strip have the same x , we may take the area of the strip for dF in the summation $\int x^2 dF$. Hence for the *rectangle* AB , Fig 479, we have from eq. (3), § 430, with $dF = bdx$,

$$\omega_o = \overline{KC} = \frac{b \int_{h_1}^{h_2} x^2 dx}{b(h_2 - h_1) \frac{h_1 + h_2}{2}} = \frac{2}{3} \cdot \frac{h_2^3 - h_1^3}{h_2^2 - h_1^2}; \quad (1)$$

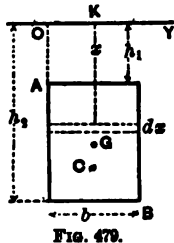

while (see note, § 430) $y_o = \frac{1}{2}b$.

When the upper base lies in the surface, $h_1 = 0$, and $\omega_o = \frac{2}{3}h_2 = \frac{2}{3}$ of the altitude.

For a *triangle with its base horizontal and vertex up*, Fig. 480, the length u of a horizontal strip is variable and $dF = udx$. From similar triangles $u = \frac{b}{h_2 - h_1}(x - h_1)$; therefore

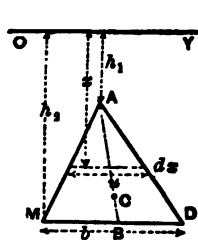

$$\omega_o = \frac{\int_{h_1}^{h_2} x^2 dF}{F \bar{x}} = \frac{b}{h_2 - h_1} \frac{\int_{h_1}^{h_2} x^2 (x - h_1) dx}{\frac{1}{2}b(h_2 - h_1)[h_1 + \frac{2}{3}(h_2 - h_1)]}$$

$$\begin{aligned} \text{But } \int_{h_1}^{h_2} x^2 (x - h_1) dx &= \left[\frac{x^3}{3} - h_1 \frac{x^2}{2} \right]_{h_1}^{h_2} \\ &= \frac{1}{12} (3h_2^3 + h_1^3 - 4h_1 h_2^2) \\ &\approx \frac{1}{12} (h_2 - h_1)^2 (3h_2^2 + 2h_1 h_2 + h_1^2); \end{aligned}$$

$$\therefore \omega_o = \frac{1}{3} \cdot \frac{3h_2^2 + 2h_1 h_2 + h_1^2}{2h_2 + h_1} \dots \dots (2)$$

Also, since the centre of pressure must lie on the line AB joining the vertex to the middle of base (see note, § 430), we easily determine its position.

Evidently for $h_1 = 0$, i.e., when the vertex is in the surface, $x_o = \frac{1}{3}h_2$. Similarly, for a triangle with base horizontal and vertex down, Fig. 481, we find that

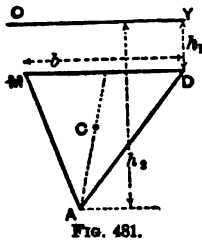

$$x = \frac{1}{2} \cdot \frac{3h_1^2 + 2h_1h_2 + h_2^2}{2h_1 + h_2} \quad (3)$$

If the base is in the surface, $h_1 = 0$ and (3) reduces to $x_o = \frac{1}{3}h_2$.

It is to be noticed that in the case of the triangle the value of x_o is the same whatever be its shape, so long as h_1 and h_2 remain unchanged and the base is horizontal. If the base is not horizontal, we may easily, by one horizontal line, divide the triangle into two triangles whose bases are horizontal and whose combined areas make up the area of the first. The resultant pressure on each of the component triangles is easily found by the foregoing principles, as also its point of application. The resultant of the two parallel forces so determined will act at some point on the line joining the centres of pressures of the component triangles, this point being easily found by the method of moments, while the amount of this final resultant pressure is the sum of its two components, since the latter are parallel. An instance of this procedure will be given in Example 3 of § 433. Similarly, the rectangle of Fig. 479 may be distorted into an oblique parallelogram with horizontal bases without affecting the value of x_o , nor the amount of resultant pressure, so long as h_1 and h_2 remain unchanged.

432. Centre of Pressure of Circle.—Fig. 482. It will lie on the vertical diameter. Let r = radius. From eq. (3), § 413,

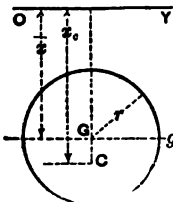

$$x_o = \frac{I_v}{F \bar{x}}; = \frac{I_g + F \bar{x}^2}{F \bar{x}} = \frac{\frac{1}{2}\pi r^4 + \pi r^2 \bar{x}^2}{\pi r^2 \bar{x}}$$

(See eq. (4), § 88, and also § 91.)

$$\therefore x_o = \bar{x} + \frac{1}{4} \cdot \frac{r^2}{\bar{x}} \quad (4)$$

FIG. 482.

493. **Examples.**—It will be noticed that although the total pressure on the plane figure depends for its value upon the head, z , of the centre of gravity, its point of application is always *lower* than the centre of gravity.

EXAMPLE 1.—If 6 ft. of a vertical sluice-gate, 4 ft. wide, Fig. 483, is below the water-surface, the total water pressure against it is (ft., lb., sec.; eq. (1), § 430)

$$P = Fz\bar{\gamma} = 6 \times 4 \times 3 \times 62.5 = 4500 \text{ lbs.,}$$

and (so far as the pressures on the vertical posts on which the gate slides are concerned) is equivalent to a single horizontal force of that value applied at a distance $x_0 = \frac{2}{3}$ of $6 = 4$ ft. below the surface (§ 431).

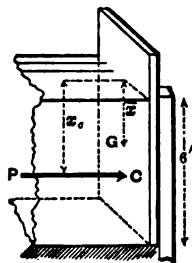

FIG. 483.

EXAMPLE 2.—To (begin to) lift the gate in Fig. 483, the gate itself weighing 200 lbs., and the coefficient of friction between the gate and posts being $f = 0.40$ (abstract numb.) (see § 156), we must employ an upward vertical force at least

$$= P' = 200 + 0.40 \times 4500 = 2000 \text{ lbs.}$$

EXAMPLE 3.—It is required to find the resultant hydrostatic pressure on the trapezoid in Fig. 483a with the dimensions there given and its bases horizontal; also its point of application, i.e., the centre of pressure of the plane figure in the position there shown. From symmetry the C. of P. will be in the middle vertical of the figure,

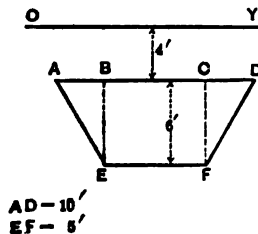

FIG. 483a.

as also that of the rectangle BCE , and that of the two triangles ABE and CDF taken together (conceived to be shifted horizontally so that CF and BE coincide on the middle vertical, thus forming a single triangle of 5 ft. base, and having the same total pressure and C. of P. as the two actual triangles taken together). Let P_1 = the total pressure, and x_0' refer to the C. of P., for the rectangle; P_2 , and x_0'' , for the 5 ft. tri-

angle; $h_1 = 4$ ft. and $h_2 = 10$ ft. being the same for both. Then from eq. (1), § 430, we have (with the ft., lb., and sec.)

$$P_1 = 30 \times 7\gamma = 210\gamma; \text{ and } P_2 = \frac{1}{2} \times 6 \times 5 \times 6\gamma = 90\gamma;$$

while from eqs. (1) and (3) of § 431 we have also (respectively)

$$x_o' = \frac{2}{3} \cdot \frac{1000 - 64}{100 - 16} = \frac{2}{3} \cdot \frac{936}{84} = 7.438 \text{ feet};$$

$$x_o'' = \frac{1}{2} \cdot \frac{48 + 80 + 100}{8 + 10} = \frac{228}{2 \times 18} = 6.333 \text{ feet.}$$

The total pressure on the trapezoid, being the resultant of P_1 and P_2 , has an amount $= P_1 + P_2$, (since they are parallel), and has a lever-arm x_o about the axis OY to be found by the principle of moments, as follows:

$$x_o = \frac{P_1 x_o' + P_2 x_o''}{P_1 + P_2} = \frac{(210 \times 7.438 + 90 \times 6.33)\gamma}{(210 + 90)\gamma} = 7.09 \text{ ft.}$$

The total hydrostatic pressure on the trapezoid is (for fresh water)

$$P = P_1 + P_2 = [210 + 90] 62.5 = 18750 \text{ lbs.}$$

EXAMPLE 4.—Required the horizontal force P' , Fig. 484, to be applied at N (with a leverage of $a' = 30$ inches about the fulcrum M) necessary to (begin

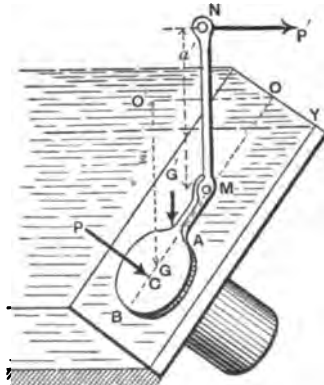

FIG. 484.

to) lift the circular disk AB of radius $r = 10$ in., covering an opening of equal size. $NMAB$ is a single rigid lever weighing $G' = 210$ lbs. The centre of gravity, G , of disk, being a vertical distance $\bar{z} = O'G = 40$ inches from the surface, is 50 inches (viz., the sum of $OM = k = 20''$ and $MG = 30''$) from axis OY ; i.e., $\bar{x} = 50$ inches.

The centre of gravity of the whole lever is a horizontal distance $b', = 12$ inches, from M .

For impending lifting we must have, for equilibrium of the lever,

$$P'a' = G'b' + P(x_o - k); \quad (1)$$

where P = total water pressure on circular disk, and $x_o = OC$. From eq. (1), § 430, (using inch, lb., and sec.,)

$$P = Fz\bar{\gamma} = \pi r^2 z\bar{\gamma} = \pi 100 \times 40 \times \frac{62.5}{1728} = 454.6 \text{ lbs.}$$

$$\text{From § 432, } x_o = \overline{OC} = \bar{x} + \frac{1}{4} \frac{r^2}{\bar{x}} = 50 + \frac{1}{4} \cdot \frac{100}{50} = 50.5 \text{ in.}$$

$$\begin{aligned} \therefore P' &= \frac{1}{a'} [G'b' + P(x_o - k)] \\ &= \frac{1}{30} [210 \times 12 + 454.6 \times 30.5] = 546 \text{ lbs.} \end{aligned}$$

434. Example of Flood-gate.—Fig. 485. double gate AD , 8 ft. in total width, to have four hinges; two at e , and two at f , 1 ft. from top and bottom of water channel; required the pressures upon them, taking dimensions from the figure (ft., lb., sec.).

Supposing the rigid

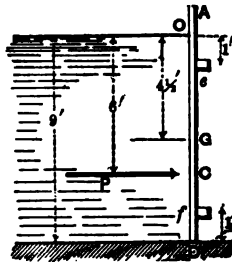

FIG. 485.

$$\begin{aligned} \text{Wat. press.} &= P = Fz\bar{\gamma} \\ &= 72 \times 4\frac{1}{2} \times 62.5 = 20250 \end{aligned}$$

pounds, and its point of application (cent. of press.) is a distance $x_o = \frac{2}{3}$ of $9' = 6'$ from O (§ 431). Considering the whole gate free and taking moments about e , we shall have

$$(\text{press. at } f) \times 7' = 20250 \times 5; \quad \therefore \text{press. at } f = 14464 \text{ lbs.}$$

(half on each hinge at f), and

$$\therefore \text{press. at } e = P - \text{press. at } f = 5875 \text{ lbs.}$$

(half coming on each hinge).

If the two gates do not form a single rigid body, and hence are not in the same plane when closed, a wedge-like or toggle-joint action is induced, producing much greater thrusts against the hinges, and each of these thrusts is not \perp to the plane of the corresponding gate. Such a case forms a good exercise for the student.

435. Stability of a Vertical Rectangular Wall against Water Pressure on One Side.—Fig. 486.

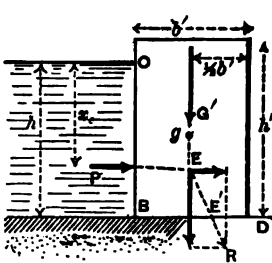

FIG. 486.

All dimensions are shown in the figure, except l , which is the length of wall \perp to paper. Supposing the wall to be a single rigid block, its weight $G' = b'h'l\gamma'$ (γ' being its heaviness (§ 7), and l its length). Given the water depth $= h$, required the proper width b' for stability. For proper security:

First, the resultant of G' and the water-pressure P must fall within the

base BD (or, which amounts to the same thing), the moment of G' about D , the outer toe of the wall, must be numerically greater than that of P ; and

Secondly, P must be less than the sliding friction fG' (see § 156) on the base BD .

Thirdly, the maximum pressure per unit of area on the base must not exceed a safe value (compare § 348).

Now $P = Fz\gamma = hl \frac{h}{2} \gamma = \frac{1}{2} h^2 l \gamma$ ($\gamma =$ heaviness of water);

and $x_0 = \frac{2}{3}h$.

Hence for stability against tipping about D ,

$$P \frac{2}{3}h \text{ must be } < G' \frac{1}{2}b'; \text{ i.e., } \frac{1}{3}h^2 l \gamma < \frac{1}{2}b^2 h^2 l \gamma'; \quad (1)$$

while, as to sliding on the base,

$$P \text{ must be } < fG'; \text{ i.e., } \frac{1}{2}h^2 l \gamma < fb^2 h^2 l \gamma'. \quad (2)$$

As for values of the coefficient of friction, f , on the base of wall, Mr. Fanning quotes the following among others, from various authorities:

For point-dressed granite on dry clay,	$f = 0.51$
“ “ “ “ “ moist clay,	0.33
“ “ “ “ “ gravel,	0.58
“ “ “ “ “ smooth concrete,	0.62
“ “ “ “ “ similar granite,	0.70
For dressed hard limestone on like limestone,	0.38
“ “ “ “ “ brickwork,	0.60
For common bricks on common bricks,	0.64

To satisfactorily investigate the third condition requires the detail of the next paragraph.

436. Parallelepipedical Reservoir Walls. More Detailed and Exact Solution.—If (1) in the last paragraph were an exact

equality, instead of an inequality, the resultant R of P and G' would pass through the corner D , tipping would be impending, and the pressure per unit area at D would be theoretically infinite. To avoid this we wish the wall to be wide enough that the resultant R , Fig. 487, may cut

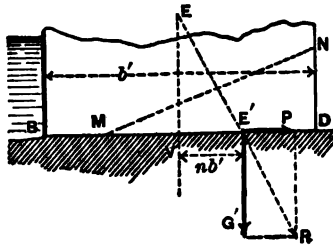

FIG. 487.

BD in such a point, E' , as to cause the pressure per unit area, p_m , at D to have a definite safe value (for the pressure p_m at D , or quite near D , will evidently be greater than elsewhere on BD ; i.e., it is the maximum pressure to be found on BD). This may be done by the principles of §§ 346 and 362.

First, assume that R cuts BD outside of the middle third; i.e., that

$$VE', = nb', > \frac{1}{3}b' \text{ (or } n > \frac{1}{3} \text{);}$$

where n denotes the ratio of the distance of E' from the middle of the base to the whole width, b' , of base. Then the pressure (per unit area) on small equal elements of the base BD (see § 346) may be considered to vary as the ordinates of a triangle MND (the vertex M being within the distance BD), and $E'D$ will = $\frac{1}{3}MD$; i.e.,

$$\overline{MD} = 3\left(\frac{1}{3} - n\right)b'$$

The mean pressure per unit area, on MD ,

$$= G' \div (l \cdot \overline{MD}),$$

and hence the maximum pressure (viz., at D), being double the mean, is

$$p_m = 2G' \div [3b'l\left(\frac{1}{3} - n\right)]; \dots (0)$$

and if p_m is to equal C' (see §§ 201 and 203), a safe value for the crushing resistance, per unit area, of the material, we shall have

$$b'l\left(\frac{1}{3} - n\right)C' = \frac{2}{3}G' = \frac{2}{3}b'h'l\gamma',$$

$$\therefore n = \frac{1}{2} - \frac{2}{3} \frac{h'\gamma'}{C'}; \dots (1)$$

To find b' , knowing n , we put the Σ (moments) of the G' and P at E , about E' , = zero (for the only other forces acting on the wall are the pressures of the foundation against it, along MD ; and since the resultant of these latter passes through E' , the sum of their moments about E' is already zero); i.e.,

$$G'nb' - P\frac{1}{3}h = 0; \text{ or, } nb'h'l\gamma' = \frac{1}{3}h \cdot \frac{1}{3}h'l\gamma;$$

$$\therefore b' = h \cdot \sqrt{\frac{h\gamma}{6nh'l\gamma'}} \dots (2)$$

Having obtained b' , we must also ascertain if P is $< fG'$, the friction; i.e., if P is $< fb'h'l\gamma'$. If not, b' must be still further increased. (Or, graphically, the resultant of G' and P must not make an angle $> \phi$, the angle of friction, with the vertical.

If n , computed from (1), should prove to be $< \frac{1}{3}$, our first assumption is wrong, and we therefore assume $n < \frac{1}{3}$, and proceed thus:

Secondly, n being $< \frac{1}{3}$ (see §§ 346 and 362), we have a

trapezoid of pressures, instead of a triangle, on BD . Let the pressure per unit area at D be p_m (the maximum on base). The whole base now receives pressure, the mean pressure (per unit area) being $= G' \div [b'l]$; and therefore, from § 362, Case I, we have

$$p_m = [6n + 1] \frac{G'}{b'l}; \dots \dots \dots (0a)$$

and since, here, $G' = b'h'l\gamma'$, we may write

$$p_m = (6n + 1)h'\gamma'.$$

For safety as to crushing resistance we put

$$6(n + 1)h'\gamma' = C'; \text{ whence } n = \frac{1}{6} \left[\frac{C'}{h'\gamma'} - 1 \right]. \dots (1a)$$

Having found n from eq. (1a), we determine the proper width of base b' from eq. (2), in case the assumption $n < \frac{1}{3}$ is verified.

EXAMPLE.—In Fig. 486, let $h' = 12$ ft., $h = 10$ ft., while the masonry weighs ($\gamma' =$) 150 lbs. per cub. ft. Supposing it desirable to bring no greater compressive stress than 100 lbs. per sq. inch (= 14400 lbs. per sq. ft.) on the cement of the joints, we put $C' = 14400$, using the ft.-lb.-sec. system of units.

Assuming $n > \frac{1}{3}$, we use eq. (1), and obtain

$$n = \frac{1}{2} - \frac{2}{3} \cdot \frac{12 \times 150}{14400} = \frac{5}{12},$$

which is $> \frac{1}{3}$; hence the assumption is confirmed, also the propriety of using eq. (1) rather than (1a).

Passing to eq. (2), we have

$$b' = 10 \times \sqrt{\frac{62.5 \times 10}{\frac{1}{3} \times 12 \times 150}} = 3.7 \text{ feet.}$$

But, as regards frictional stability, we find that, with $f = 0.30$, a low value, and $b' = 3.7$ ft. (ft., lb., sec.),

$$\frac{P}{fG'} = \frac{\frac{1}{2}h^2\gamma}{f'b'h'\gamma'} = \frac{100 \times 62.5}{2 \times 0.3 \times 3.7 \times 12 \times 150} = 1.5;$$

which is greater than unity, showing the friction to be insufficient to prevent sliding (with $f = 0.30$); a greater width must therefore be chosen, for frictional stability.

If we make $n = \frac{1}{3}$, i.e., make R cut the base at the outer edge of middle third (§ 362), we have, from eq. (2),

$$b' = 10 \times \sqrt{\frac{62.5 \times 10}{\frac{1}{3} \times 12 \times 150}} = 5.89 \text{ feet};$$

and the pressure at D is now of course well within the safe limit; while as regards friction we find

$$P \div fG' = 0.92, < \text{unity},$$

and therefore the wall is safe in this respect also.

With a width of base = 3.7 feet first obtained, the portion MD , Fig. 487, of the base which receives pressure [according to Navier's theory (§ 346)] would be only 0.92 feet in length, or about one sixth of the base, the portion BM tending to open, and perhaps actually suffering tension, if capable (i.e., if cemented to a rock foundation), in which case these tensions should properly be taken into account, as with beams (§ 295), thus modifying the results.

It has been considered safe by some designers of high masonry dams, to neglect these possible tensile resistances, as has just been done in deriving $b' = 3.7$ feet; but others, in view of the more or less uncertain and speculative character of Navier's theory, when applied to the very wide bases of such structures, prefer, in using the theory (as the best available), to keep the resultant pressure within the middle third at the base (and also at all horizontal beds above the base), and thus avoid the chances of tensile stresses.

This latter plan is supported by Messrs. Church and Fteley, as engineers of the proposed Quaker Bridge Dam in connection with the New Croton Aqueduct of New York City, in their report of 1887. See § 438.

437. Wall of Trapezoidal Profile. Water-face Vertical.—Economy of material is favored by using a trapezoidal profile, Fig. 488. With this form the stability may be investigated in a corresponding manner. The portion of wall above each horizontal bed should be examined similarly. The weight G' acts through the centre of gravity of the whole mass.

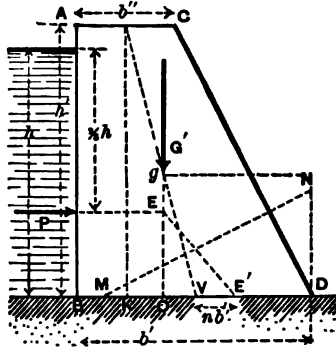

FIG. 488.

Detail.—Let Fig. 488 show the vertical cross-section of a trapezoidal wall, with notation for dimensions as indicated; the portion considered having a length = l , \perp to the paper. Let γ = heaviness of water, γ' that of the masonry (assumed homogeneous), with n as in § 436.

For a *triangle of pressure*, MD , on the base, i.e., with $n > \frac{1}{3}$, or resultant falling outside the middle third (neglecting possibility of tensile stresses on left of M), if the intensity of pressure p_m at D is to = C' (§ 203), we put, as in § 436,

$$b'l\left[\frac{1}{3} - n\right]C' = \frac{1}{3}G', \text{ i.e., } = \frac{1}{3}h' \cdot \frac{1}{3}(b' + b'')\gamma',$$

whence

$$n = \frac{1}{2} - \frac{1}{3} \frac{h'\gamma'}{C'} \cdot \frac{b' + b''}{b'} \dots \dots (1')$$

For a *trapezoid of pressure*, i.e. with $n < \frac{1}{3}$, or the resultant of P and G' falling within the middle third, we have, as before (§ 362, Case I),

$$p_m, \text{ or } C', = (6n + 1) \frac{G'}{b'l};$$

whence

$$n = \frac{1}{6} \left[\frac{C'b'l}{G'} - 1 \right]; \text{ i.e., } n = \frac{1}{6} \left[\frac{2C'b'}{h'\gamma'(b' + b'')} - 1 \right]. \quad (1a')$$

From the geometry of the figure, having joined the middles of the two bases, we have

$$\bar{y}, = \bar{gO}, = \frac{h'}{3} \cdot \frac{b' + 2b''}{b' + b''}$$

(§ 26, Prob. 6), and, by similar triangles, $\overline{OV} : \overline{KV} :: \bar{gO} : h'$, whence

$$\overline{OV} = \frac{\bar{y}}{h'} \cdot \frac{1}{2} [b' - b''];$$

$$\therefore \overline{OE'}, = \overline{OV} + \overline{VE'}, = \frac{1}{6} \cdot \frac{(b' + 2b'')(b' - b'')}{b' + b''} + nb'.. (a)$$

The lines of action of G' and P meet at E , and their resultant cuts the base in some point E' . The sum of their moments about E' should be zero, i.e., $P \cdot \frac{1}{3}h = G' \cdot \overline{OE'}$; that is, (see eq. (a) above, and eq. (1), § 430,)

$$\frac{1}{3}h^2\gamma = lh'\gamma' \frac{1}{3}(b' + b'') \left[\frac{1}{6} \cdot \frac{(b' + 2b'')(b' - b'')}{b' + b''} + nb' \right]; (b)$$

i.e., cancelling,

$$h^2\gamma = \frac{1}{3}h'\gamma' [(b' + 2b'')(b' - b'') + 6nb'(b' + b'')]. (2)'$$

Hence we have two equations for finding two unknowns viz.: (1) and (2)' when $n > \frac{1}{3}$; and (1a)' and (2)' when $n < \frac{1}{3}$.

For dams of small height (less than 40 ft., say), if we immediately put $n = \frac{1}{3}$, thus restricting the resultant pressure to the edge of middle third, and solve (2)' for b' , b'' being assumed of some proper value for a coping, foot-walk, or roadway, while h' may be taken enough greater than h to provide against the greatest height of waves, from 2.5 to 6 ft., the value of p_m at D will probably be $< C'$. In any case, for a value of $n =$, or $<$, $\frac{1}{3}$ we put p_m for C' in equation (1a)' and solve for p_m , to determine if it is no greater than C' .

Mr. Fanning recommends the following values for C' (*in lbs.*

per sq. foot) with coursed rubble masonry laid in strong mortar :

	For Limestone.	Sandstone.	Granite.	Brick.
C'	= 50,000	50,000	60,000	35,000
Av. heaviness of the masonry in lbs. per cub. ft.	} 152	} 132	} 154	} 120

As to *frictional resistance*, P must be $< fG'$; i.e.,

$$\frac{1}{2}h^2\gamma < fh'\gamma\frac{1}{2}(b' + b''). \dots \dots (3)'$$

If the base is cemented to a *rock foundation* with good material and workmanship throughout, Messrs. Church and Fteley (see § 436) consider that the wall may be treated as amply safe against sliding on the base (or any horizontal bed), provided the other two conditions of safety are already satisfied.

438. **Triangular Wall with Vertical Water-face.**—Making $b'' = 0$ in the preceding article, the trapezoid becomes a *right triangle*, and the equations reduce to the following :

$$p_m = \frac{2h'\gamma'}{3 - 6n} \text{ for } n > \frac{1}{3}, \dots \dots (1)''$$

and

$$p_m = \frac{1}{2}h'\gamma'[6n + 1] \text{ for } n < \frac{1}{3} \dots \dots (1a)''$$

(p_m not to exceed C' in any case); while to determine the breadth of base, b' , after n is computed [or assumed, for small height of wall], we have from eq. (2)',

$$h^2\gamma = \frac{1}{2}h'b'^2\gamma'[6n + 1]. \dots \dots (2)''$$

Also, for frictional stability,

$$\frac{1}{2}h^2\gamma \text{ must be } < \frac{1}{2}fh'b'\gamma'. \dots \dots (3)''$$

439. High Masonry Dama.—Although the principle of the arch may be utilized for vertical stone dikes of small height (30 to 50 feet) and small span, for greater heights and spans the formula for hoop tension, § 426 (or rather, here, “hoop compression”), on the vertical radial joints of the horizontal arch rings, Fig. 489, calls for so great a radial thickness of joint in the lower courses, that straight dikes (or “gravity dams”) are usually built instead, even

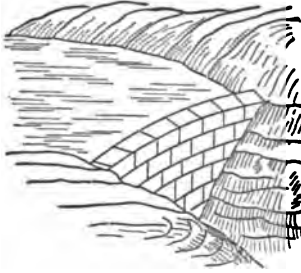

FIG. 489.

where firm rock abutments are available laterally.

For example, at a depth of 100 feet, where the hydrostatic pressure is $h\gamma = 100 \times 62.5 = 6250$ lbs. per sq. ft., if we assume for the voussoirs a (radial, horizontal) thickness = 4 ft., with a (horizontal) radius of curvature $r = 100$ feet, we shall find a compression between their vertical radial faces of (ft., lb., sec.)

$$p'' = \frac{r(p - p_a)}{t} = \frac{100 \times 6250}{4} = 156250 \text{ lbs. per sq. ft.,}$$

or 1085 lbs. per sq. inch; far too great for safety, even if there were no danger of collapse, the dike being short. If now the thickness is increased, in order to distribute the pressure over a greater surface, we are met by the fact that the formula for “hoop compression” is no longer strictly applicable, the law of distribution of pressure becoming very uncertain; and even supposing a uniform distribution over the joint, the thickness demanded for proper safety against crushing is greater than for a straight dam (“gravity dam”) at a very moderate depth below the water surface, unless the radius of curvature of arch can be made small. But the smaller the radius the more does the dam encroach on the storage capacity of the reservoir, while in no case, of course, can it be made smaller than half the span.

Another point is, that as masonry is not destitute of elasticity, the longer the span the more unlikely is it that the parts of the arch will “close up” properly, and develop the

abutment reactions when the water is first admitted to the reservoir; which should occur if it is to act as an arch instead of by gravity resistance.

For these reasons the engineers of the proposed Quaker Bridge Dam reported unfavorably to the plan of a curved design for that structure, and recommended that a straight dam be built. See reference in § 436. According to their designs this dam is to be 258 feet in height (which exceeds by about 90 feet the height of any dam previously built), about 1400 feet in length at the top, and 216 feet in width at the lowest point of base, joining the bed-rock.

More recently, however (1888), a board of experts, specially appointed for the purpose, having examined a number of different plans, have reported favorably to the adoption of a curved form for the dam, as offering greater resistance under extraordinary circumstances (impact of ice-floes, earthquakes, etc.), on account of its arched form (though resisting by gravity action under usual conditions) than a straight structure; and also as more pleasing in appearance.

Fig. 490 shows the profile of a straight high masonry dam as designed at the present day. Assuming a width $b'' =$ from 6 to 22 feet at the top, and a sufficient h'' (see figure) to exceed the maximum height of waves, the up-stream outline ACM is made nearly vertical and perhaps somewhat concave, while the down-stream profile BDN , by computation or graphical trial, or both, is so formed that *when the reservoir is full* the resultant R , of the weight

G of the portion $ABCD$ of masonry above *each* horizontal bed, as CD , and the hydrostatic pressure P on the corresponding up-stream face AC , shall cut the bed CD in such a point E' as not to cause too great compression p_m at the outer edge D (not over 85 lbs. per sq. inch according to M. Krantz in "Reservoir Walls"), p_m being computed by one of the equations [(0) and (0a) of § 436]

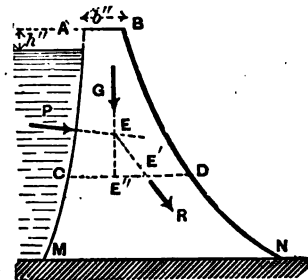

FIG. 490.

$$\left. \begin{array}{l} \text{For } E' \text{ outside the middle third} \\ \text{and neglecting tension} \end{array} \right\} \cdot p_m = \frac{2G}{3 \cdot CD \cdot l \left(\frac{1}{3} - n\right)}; (1)''$$

$$\text{For } E' \text{ inside middle third} \left\} \cdot p_m = \frac{(6n + 1)G}{CD \cdot l}; (1a)'''$$

where l = length of wall γ to paper, usually taken = one foot, or one inch, according to the unit of length adopted; for n , see § 436.

Nor, when the reservoir is empty and the water pressure lacking, must the weight G resting on each bed, as CD , cut the bed in a point E'' so near the edge C as to produce excessive pressure there (computed as above). The figure shows the general form of profile resulting from these conditions. The masonry should be of such a character, by irregular bonding in every direction, as to make the wall if possible a monolith. For more detail see next paragraph.

440. Quaker Bridge Dam (on the New Croton Aqueduct).—Attempts, by strict analysis, to determine the equation of the curve BN , AM being assumed straight, so as to bring the point E' at the outer edge of the middle third of its joint, or to make the pressure at D constant below a definite joint, have failed, up to the present time; but approximate and tentative methods are in use which serve all practical purposes. As an illustration the method set forth in the report on the Quaker Bridge Dam will be briefly outlined; *this method confines E' to the middle third.*

The width $AB = b''$ is taken = 22' for a roadway, and $h'' = 7$ ft. The profile is made a vertical rectangle from A down to a depth of 33 ft. below the water surface (*reservoir full*). Combining the weight of this rectangle of masonry with the corresponding water pressure (for a length of wall = one foot), we find the resultant pressure comes a little within the outer edge of the middle third of the base of the rectangle, while p_m is of course small.

The rectangular form of profile might be continued below this horizontal joint, as far as complying with the middle

third requirement, and the limitation of pressure-intensity, is concerned; but, not to make the widening of the joints too abrupt in a lower position where it would be absolutely required, a beginning is made at the joint just mentioned by forming a trapezoid between it and a joint 11 ft. farther down, making the lower base of the latter of some trial width, which can be altered when the results to which it gives rise become evident. Having computed the weight of this trapezoid and constructed its line of action through the centre of gravity of the trapezoid, the value of the resultant G of this weight and that of the rectangle is found (by principle of moments or by an equilibrium polygon) in amount and position, and combined with the water pressure of the corresponding 44 ft. of water to form the force R , whose point of intersection with the new joint or bed (lower base of trapezoid) is noted and the value of p_m computed. These should both be somewhat nearer their limits than in the preceding joint. If not, a different width should be chosen, and changed again, if necessary, until satisfactory. Similarly, another layer, 11 ft. in height and of trapezoidal form, is added below and treated in the same way; and so on until in the joint at a depth of 66 ft. from the water surface a width is found where the point E' is very close upon its limiting position, while p_m is quite a little under the limit set for the upper joints of the dam, 8 tons per square foot. For the next three 11 ft. trapezoidal layers the chief governing element is the middle-third requirement, E' being kept quite close to the limit, while the increase of p_m to 7.95 tons per sq. ft. is unobjectionable; also, we begin to move the left-hand edge to the left of the vertical, so that when the reservoir is empty the point E'' shall not be too near the upstream edge C .

Down to a depth of about 200 ft. the value of p_m is allowed to increase to 10.48 tons per sq. ft., while the position of E' gradually retreats from the edge of its limit. Beyond 200 ft. depth, to prevent a rapid increase of width and consequent extreme flattening of the down-stream curve, p_m is allowed to mount rapidly to 16.63 tons per sq. ft. (= 231 lbs. per sq. in.), which value it reaches at the point N of the base of

the dam, which has a width = 216 ft., and is 258 feet below the water surface when the reservoir is full.

The heaviness of the masonry is taken as $\gamma' = 156.25$ lbs. per cubic foot, just $\frac{1}{4}$ of $\gamma = 62.5$ lbs. per cub. foot, the heaviness taken for water.

When the *reservoir is empty*, we have the weight G of the superincumbent mass resting on any bed CD , and applied through the point E'' ; the pressure per unit area at C can then be computed by eq. (1a)''', § 439, n being the quotient of $(\frac{1}{2}CD - CE'')$ \div CD for this purpose. In the present case we find E'' to be within middle third at all joints, and the pressures at C to be under the limit.

For further details the reader is referred to the report itself (reprinted in *Engineering News*, January, 1888, p. 20). The graphic results were checked by computation, Wegmann's method, applied to each trapezoid in turn.

441. Earthwork Dam, of Trapezoidal Section.—Fig. 491. It is

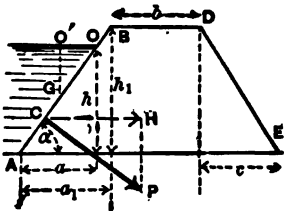

FIG. 491.

required to find the conditions of stability of the straight earthwork dam $ABDE$, whose length = l , L to paper, as regards sliding horizontally on the plane AE ; i.e., its frictional stability. With the dimensions of the figure, γ and γ' being the heavinesses of the water and earth respectively (see § 7), we have

$$\text{Weight of dam} = G, = \text{vol.} \times \gamma' = lh_1[b + \frac{1}{2}(a + c)]\gamma'. \quad (1)$$

$$\text{Resultant water press.} = P = F \bar{z} \gamma = \overline{OA} \times l \times \frac{1}{2}h\gamma. \quad (2)$$

$$\begin{aligned} \text{Horiz. comp. of } P &= H = P \sin \alpha \\ &= [\overline{OA} \sin \alpha] \frac{1}{2}hl\gamma = \frac{1}{2}h^2l\gamma. \quad \dots \quad (3) \end{aligned}$$

From (3) it is evident that the horizontal component of P is just the same, viz., $= hl \cdot \frac{1}{2}h\gamma$, as the water pressure would be on a vertical rectangle equal to the vertical projection of OA

and with its centre of gravity at the same depth ($\frac{1}{3}h$). Compare §416. Also,

$$\begin{aligned} \text{Vert. comp. of } P &= V = P \cos \alpha \\ &= [\overline{OA} \cos \alpha] \frac{1}{3} h \gamma = \frac{1}{3} a h \gamma, \quad \dots \quad (4) \end{aligned}$$

and is the same as the water pressure on the horizontal projection of OA if placed at a depth $= O'G = \frac{1}{3}h$.

For stability against sliding, the horizontal component of P must be less than the friction due to the total vertical pressure on the plane AE , viz., $G_1 + V$; hence if f is the coefficient of friction on AE , we must have $H < f [G_1 + V]$, i.e. (see above),

$$\frac{1}{3} h^2 \gamma \text{ must be } < f \left[h_1 \left[b + \frac{1}{2}(a_1 + c) \right] \gamma' + \frac{1}{3} a h \gamma \right]. \quad (5)$$

However, if the water leak under the dam on the surface AE , so as to exert an upward hydrostatic pressure

$$V' = [a_1 + b + c] h \gamma,$$

(to make an extreme supposition,) the friction will be only

$$= f [G_1 + V - V'],$$

and (5) will be replaced by

$$H < f [G_1 + V - V']. \quad \dots \quad (6)$$

Experiment shows (Weisbach) that with $f = 0.33$ computations made from (6) (treated as a bare equality) give satisfactory results.

EXAMPLE.—(Ft., lb., sec.) With $f = 0.33$, $h = 20$ ft., $h_1 = 22$ ft., $a = 24$ ft., $a_1 = 26.4$ ft., and $c = 30$ ft., we have, making (6) an equality, with $\gamma' = 2\gamma$,

$$\frac{1}{3} h^2 \gamma = f \left[\gamma' h_1 \left(b + \frac{a_1 + c}{2} \right) + \frac{1}{3} a h \gamma - (a_1 + b + c) h \gamma \right];$$

$$\therefore \frac{1}{3}(400) = \frac{1}{3} [22(b + 28.2)2 + \frac{1}{3}(24 \times 20) - (26.4 + b + 30)20];$$

whence, solving for b , the width of top, $b = 10.3$ feet.

442. Liquid Pressure on Both Sides of a Gate or Rigid Plate.—

The sluice-gate *AB*, for example, Fig. 492, receives a pressure, P_1 , from the “head-water” *M*, and an opposing pressure P_2 from the “tail-water” *N*. Since these two horizontal forces are not in the same line, though parallel, their resultant R , which = $P_1 - P_2$, acts horizontally in the same plane, but at a distance below $O_1 = u$, which we may find by placing the moment of R about O_1 , equal to the algebraic sum of those of P_1 and P_2 about O_1 .

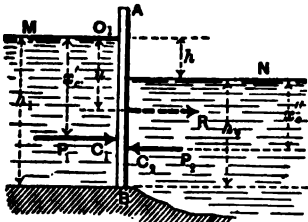

FIG. 492.

$$\therefore Ru = P_1x_o' - P_2(x_o'' + h). \dots (1)$$

$$\therefore u = \frac{[P_1x_o' - P_2(x_o'' + h)]}{P_1 - P_2} \dots (2)$$

C_1 and C_2 are the respective centres of pressure of the surfaces O_1B and O_2B , and u = distance of R from O_1 , while h = difference of level between head and tail waters. If the surfaces O_1B and O_2B are both rectangular,

$$x_o' = \frac{2}{3}h, \text{ and } x_o'' = \frac{2}{3}h.$$

EXAMPLE.—Let the dimensions be as in Fig. 493, both surfaces under pressure being rectangular and 8 ft. wide. Then (ft., lb., sec.) $R = P_1 - P_2$, or (§ 430)

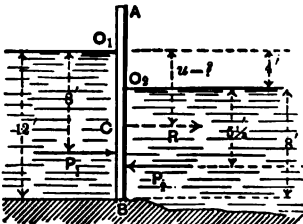

FIG. 493.

Then (ft., lb., sec.) $R = P_1 - P_2$, or (§ 430)

$$R = [12 \times 8 \times 6 - 8 \times 8 \times 4]62.5 = 20000 \text{ lbs.} = 10 \text{ tons};$$

while from ex. (2)

$$u = \frac{[12 \times 8 \times 6 \times 8 - 8 \times 8 \times 4(9\frac{1}{2})]62.5}{20000}$$

That is, $u = 6.93$ feet, which locates C . Hence the pressure of the gate upon its hinges or other support is the same (aside

from its own weight), provided it is rigid, as if the single horizontal force $R = 10$ tons acted at the point C , 2.93 ft. below the level of the tail-water surface.

443. If the plate, or gate, is entirely below the tail-water surface, the resultant pressure is applied in the centre of gravity of the plate.—Proof as follows: Conceive the surface to be divided into a great number of small equal areas, each = dF ; then, the head of water of any dF being = x_1 on the head-water side, and = x_2 on the tail-water side, the resultant pressure on the dF is $\gamma dF(x_1 - x_2) = \gamma h dF$, in which h is the difference of level between head and tail water. That is, the resultant pressures on the equal dF 's are equal, and hence form a system of equal parallel forces distributed over the plate in the same manner as the weights of the corresponding portions of the plate; therefore their single resultant acts through the centre of gravity of the plate; Q. E. D. This single resultant = $\int \gamma h dF = \gamma h \int dF = F h \gamma$.

EXAMPLE.—Fig. 494. The resultant pressure on a circular disk ab of radius = 8 inches, (in the vertical partition OK), which has its centre of gravity 3 ft. below the tail-water surface, with $h = 2$ ft., is (ft., lb., sec.)

$$R = F h \gamma = \pi r^2 h \gamma$$

$$= \pi 8^2 \times 24 \times \frac{62.5}{1728} = 174.6 \text{ lbs.,}$$

and is applied through the centre of gravity of the circle. Evidently R is the same for any depth below the tail-water surface, so long as $h = 2$ ft. [Let the student find a graphic proof of this statement.]

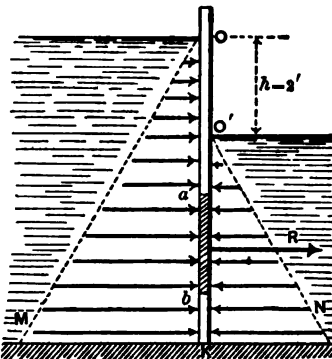

FIG. 494.

- C 444. Liquid Pressure on Curved Surfaces.—If the rigid surface is curved, the pressures on the individual dF 's, or elements of area, do not form a system of parallel forces, and the single resultant (if one is obtainable) is not equal to their sum. In

general, the system is not equivalent to a single force, but can always be reduced to two forces (§ 38) the point of application of *one of which* is arbitrary (the arbitrary origin of § 38) and its amount = $\sqrt{(\Sigma X)^2 + (\Sigma Y)^2 + (\Sigma Z)^2}$.

A single Example will be given ; that of a thin rigid shell having the shape of the curved surface of a right cone, Fig. 495, its altitude being h and radius of base = r . It has no bottom, is placed on a smooth horizontal table, vertex up, and is filled with water through a small hole in the apex O , which is

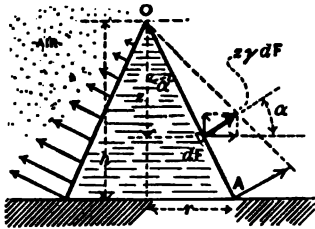

FIG. 495.

left open (to admit atmospheric pressure). What load, besides its own weight G' , must be placed upon it to prevent the water from lifting it and escaping under the edge A ? The pressure on each dF of the inner curved surface is $z\gamma dF$ and is normal to the surface.

Its vertical compon. is $z\gamma dF \sin \alpha$, and horizontal compon. = $z\gamma dF \cos \alpha$. The dF 's have all the same α , but different z 's (or heads of water). The lifting tendency of the water on the thin shell is due to the vertical components forming a system of \parallel forces, while the horizontal components, radiating symmetrically from the axis of the cone, neutralize each other. Hence the resultant lifting force is

$$V = \Sigma(\text{vert. comps.}) = \gamma \sin \alpha \int z dF = \gamma \sin \alpha F \bar{z}; \quad (1)$$

where F = total area of curved surface, and \bar{z} = the "head of water" of its centre of gravity. Eq. (1) may also be written thus:

$$V = \gamma F_b \bar{z}; \quad \dots \dots \dots (2)$$

in which $F_b = F \sin \alpha$ = area of the circular base = area of the *projection of the curved surface upon a plane* \perp to the vertical, i.e., upon a horizontal plane. Hence we may write

$$V = \frac{2}{3} \gamma \pi r^2 h, \quad \dots \dots \dots (3)$$

since $\bar{z} = \frac{2}{3} h$, being the z of the centre of gravity of the curved

surface and not that of the base. γ = heaviness of water. If G' = weight of the shell and is $< V$, an additional load of $V - G'$ will be needed to prevent the lifting. If the shell has a bottom of weight = G'' , forming a base for the cone and rigidly attached to it, we find that the vertical forces acting on the whole rigid body, base and all, are: V upward; G' and G'' downward; and the liquid pressure on the base, viz., $V' = \pi r^2 h \gamma$ (§ 428a) also downward. Hence the resultant vertical force to be counteracted by the table is downward, and

$$= G' + G'' + V' - V, \text{ which } = G' + G'' + \frac{1}{3}\pi r^2 h \gamma; \quad (4)$$

i.e., the total weight of the rigid vessel and the water in it, as we know, of course, in advance.

CHAPTER III.

EARTH PRESSURE AND RETAINING WALLS.

[NOTE.—This chapter was outlined and written mainly by Prof. C. L. Crandall, and is here incorporated with his permission. The theory of earth pressure is arranged from Bausemeister.]

445. Angle of Repose.—Granular materials, like dry sand, loose earth, soil, gravel, pease, shot, etc., on account of the friction between the component grains, occupy an intermediate position between liquids and large rigid bodies. When heaped up, the side of the mass cannot be made to stand at an inclination with the horizontal greater than a definite angle called the *angle of natural slope*, or *angle of repose*, different for each material; so that if the side of the mass is to be retained permanently at some greater angle, a *Retaining Wall* (or "*Revetment Wall*," in military parlance) becomes necessary to support it. If the material is somewhat moist it may be made to stand alone at an inclination greater than that of the natural slope, on account of the cohesion thus produced, but only as long as the degree of moisture remains; while if much water is present, it assumes the consistency of mud and may require a much thicker wall, if it is to be supported laterally, than if dry.

In dealing with earth to be supported by a retaining wall, we consider the former to have lost any original cohesion which may have existed among its particles, or that it will eventually lose it through the action of the weather; and hence treat it as a granular material.

A few approximate values of the angle of natural slope are

given below, being taken from Fanning, p. 345; see reference on p. 538 of this work.

MATERIAL.	Angle of Repose.	Coefficient of Friction.	Ratio of Slope.
			Horiz. to vert.
Dry sand, fine.....	28°	.533	1.88 to 1
" coarse.....	30°	.577	1.73 " 1
Damp clay.....	45°	1.000	1.00 " 1
Wet clay.....	15°	.268	3.73 " 1
Clayey gravel.....	45°	1.000	1.00 " 1
Shingle.....	42°	.900	1.11 " 1
Gravel.....	38°	.781	1.28 " 1
Firm loam.....	36°	.727	1.38 " 1
Vegetable soil.....	35°	.700	1.43 " 1
Peat.....	20°	.364	2.75 " 1

The angle of repose, or natural slope, is also, evidently, the angle of friction between two masses of the same granular material.

446. Earth Pressure, and Wedge of Maximum Thrust.—Fig. 496. Let AB be a retaining wall, having a plane face AB in contact with a mass of earth ABD , both wall and earth being of indefinite extent \uparrow to the paper.

Let AD be the natural slope of the earth, making an angle β with the vertical (β is the complement of the angle of repose; see preceding table). Since AB , making an angle α with the vertical, is more nearly vertical than AD , the retaining wall is necessary, to keep the mass ABD in the position shown. The profile BCD may be of *any form* in this general discussion. Suppose the wall to be on the point of giving way; then the following motions are impending:

1st. Sliding is impending between some portion $ABC'A$ of the mass of earth and the remainder $C'AD$, the *surface of rupture* AC' (C' not shown in figure because not found yet, but lying somewhere on the profile $BCID$) being assumed plane, and making some angle ϕ' (to be determined) with the vertical. At this instant the resultant pressure N' of $AC'D$ on the plane AC' of the mass ABC' (a wedge) must *make an angle* $= \beta$ ($=$ comp. of angle of friction) with AC' on the upper side.

2d. A downward sliding of the mass ABC' along the back face AB of the wall. That is, the resultant pressure P' of the wall against the mass BAC' at this instant *makes an angle*

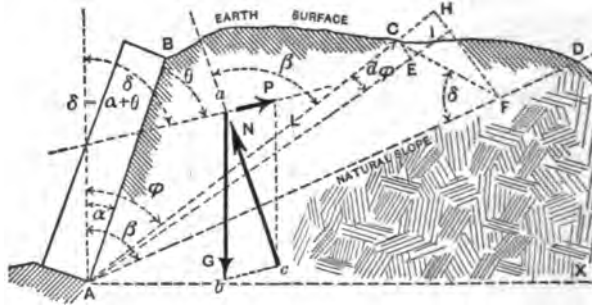

FIG. 496.

θ (= complement of angle of friction between the earth and wall) with the plane AB and on the upper side. The weight of the wedge of earth BAC' will be called G' , and we desire to find the pressure P' against the wall.

Let BAC be a wedge (of the earth-mass), in which AC makes any angle ϕ with AV , and suppose it to be on the point of moving down and forcing out the wall; thus encountering friction both on the plane AC and the plane AB . Then the forces acting on it are three, acting in known directions; viz.: G , its own weight, vertical; N , the resultant pressure of the earth below it, making an angle β with AC on upper side; and P , the resultant pressure of the wall, at angle θ with AB (see Fig. 496 for positions of N and P). If now we express the force P in terms of ϕ and other quantities, and find that value ϕ' , of ϕ , for which P is a maximum, we thereby determine the "*wedge of maximum thrust*," $ABC'A$; while this maximum thrust, P' , is the force which the wall must be designed to withstand. [If the wall is overturned, the earth will sink with it until this part of its surface gradually assumes the natural slope.]

Let G = weight of prism of base ABC , and altitude = unity \uparrow to paper; then $G = \gamma \times \text{area } ABC$, where γ = "heaviness" = wgt. per cub. unit, of earth. Now P , G , and N balance; therefore, in triangle abc , if ab and ac are drawn \parallel

and = G and N respectively, bc is = and \parallel to P ; and from Trigonometry we have

$$P = G \frac{\sin [\beta - \phi]}{\sin [\beta + \delta - \phi]}; \quad \dots \dots (1)$$

in which δ stands for $\alpha + \theta$, for brevity, being the angle which P makes with the vertical. N makes an angle = $\beta - \phi$ with the vertical.

The value, ϕ' , of ϕ , which makes P a maximum is found by placing $\frac{dP}{d\phi} = 0$. From eq. (1), remembering that G is a function of ϕ , and that β and δ are constants, we have

$$\frac{dP}{d\phi} = \frac{\sin (\beta + \delta - \phi) \left[\frac{dG}{d\phi} \sin (\beta - \phi) - G \cos (\beta - \phi) \right] + G \sin (\beta - \phi) \cos (\beta + \delta - \phi)}{\sin^2 [\beta + \delta - \phi]}$$

For P to be a maximum we must put

$$\text{numerator of above} = 0. \quad \dots \dots (a)$$

To find a geometrical equivalent of $\frac{dG}{d\phi}$, denote \overline{AC} by L , and draw AE , making an angle = $d\phi$ with AC . Now the area $ACI = \overline{AI} \times \frac{1}{2} \overline{CE} = (L + dL) \frac{1}{2} L d\phi = \frac{1}{2} L^2 d\phi \dots$ (neglecting infinitesimal of 2d order). Now

$$dG = \gamma \times \text{area } ACI \times \text{unity}; \quad \therefore \frac{dG}{d\phi} = \frac{1}{2} \gamma L^2; \quad \therefore (a) \text{ becomes}$$

$$\begin{aligned} &\sin (\beta + \delta - \phi) \frac{1}{2} \gamma L^2 \sin (\beta - \phi) - \sin (\beta + \delta - \phi) G \cos (\beta - \phi) \\ &+ G \sin (\beta - \phi) \cos (\beta + \delta - \phi) = 0; \end{aligned}$$

i.e., $G =$

$$\frac{\frac{1}{2} \gamma L^2 \sin (\beta - \phi) \sin (\beta + \delta - \phi)}{\sin (\beta + \delta - \phi) \cos (\beta - \phi) - \cos (\beta + \delta - \phi) \sin (\beta - \phi)}$$

when P is a maximum; and hence, calling G' and ϕ' and L' the values of G , ϕ , and L , for max. P , we have

$$G' = \frac{1}{2}\gamma L' \frac{\sin(\beta - \phi') \sin(\beta + \delta - \phi')}{\sin \delta}, \dots (2)$$

and therefore from (1) P max. itself is

$$P = \frac{1}{2}\gamma L' \frac{\sin^2(\beta - \phi')}{\sin \delta}. \dots (3)$$

447. Geometric Interpretation and Construction.—If in Fig. 496 we draw CF , making angle δ with AD , C being any point on the ground surface BD , we have

$$\overline{CF} = L \frac{\sin(\beta - \phi)}{\sin \delta}$$

Drop a perpendicular FH from F to AC , and we shall have

$$\overline{FH} = \overline{CF} \cdot \sin(\beta + \delta - \phi) = L \frac{\sin(\beta - \phi) \sin(\beta + \delta - \phi)}{\sin \delta}$$

From this it follows that the weight of prism of base ACF and unit height

$$= \frac{1}{2}\gamma L \cdot \overline{FH} = \frac{1}{2}\gamma L^2 \frac{\sin(\beta - \phi) \sin(\beta + \delta - \phi)}{\sin \delta} \quad (4)$$

When AC (as ϕ varies) assumes the position and value AC' , bounding the prism of maximum thrust, Fig. 497, L becomes $= L'$, and $\phi = \phi'$; and eq. (4) gives the weight of the prism $AC'F'$. This weight is seen to be equal to that of the prism (or wedge) of maximum thrust ABC' , by comparing eq. (4) with eq. (2); that is, AC' bisects the area $ABC'F'$, and hence may be determined by fixing such a point C' , on the upper profile BD , as to make the triangular area $AC'F'$ equal to the sectional area of the wedge $BC'A$; $C'F'$ being drawn at an angle $= \delta$ with AD .

This holds for any form of ground surface BD , or any

values of the constants β , α , or θ . C' is best found graphically by trial, in dealing with an irregular profile BD .

Having found AC' , = L' , P' can be found from (3), or *graphically* as follows: (Fig. 497) With F' as a centre and radius = $C'F'$, describe an arc cutting AD in J' , and join $C'J'$. The weight of prism with base $C'J'F'$ and unit height will = P' . For that prism has a weight

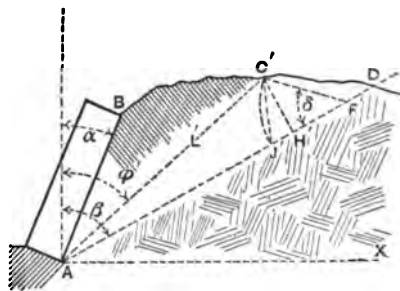

FIG. 497.

$$= \frac{1}{2} \gamma \cdot \overline{F'J'} \cdot \overline{C'H'};$$

but
$$\overline{F'J'} = \overline{F'C'} = \frac{L' \sin(\beta - \phi')}{\sin \delta},$$

and
$$\overline{C'H'} = L' \sin(\beta - \phi');$$

\therefore weight of prism $C'J'F' = \frac{1}{2} \gamma L'^2 \frac{\sin^2(\beta - \phi')}{\sin \delta}; = P'.$

[See eq. (3).]

448. Point of Application of the Resultant Earth Thrust.—This thrust (called P' throughout this chapter *except in the present paragraph*) is now known in magnitude and direction, but not in position; i.e., we must still determine its line of action, as follows:

Divide AB into a number of equal parts, ab, bc, cd , etc.; see Fig. 498. Treat ab as a small retaining wall, and find the magnitude P' of the thrust against it by § 447; treat ac similarly, thus finding the thrust, P'' , against it; then ad, ae , etc., the thrusts against them being found to be P''' , P'''' , etc.; and so on. Now the pressure

P' on ab is applied nearly at middle of ab ,
 $P'' - P'$ " " " " bc ,
 $P''' - P''$ " " " " cd ,

and so on. Erect perpendiculars at the middle points of ab , bc , cd , etc., equal respectively to P' , $P'' - P'$, $P''' - P''$, etc., and join the ends of the perpendiculars. The perpendicular through the centre of gravity of the area so formed (Fig. 498) will give, on AB , the required point of application of the thrust or earth pressure on AB , and this, with the direction and magnitude already found in § 447, will completely determine the thrust against the wall AB .

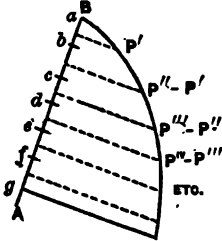

FIG. 496.

449. Special Law of Loading.—If the material to be retained consists of loose stone, masses of masonry, buildings, or even moving loads, as in the case of a wharf or roadway, each can be replaced by the same *weight* of earth or other material which will render the bank homogeneous, situated on the *same verticals*, and the profile thus reduced can be treated by §§ 447 and 448.

Should the solid mass extend below the plane of rupture, AC' , and the plane of natural slope, it will become a retaining wall for the material beyond, if strong enough to act as such (limiting the profile $ABCD$ of Fig. 496 to the front of the mass, or to the front and line of rupture for maximum thrust above it, if it does not reach the surface); if not strong enough, or if it does not reach below the plane of natural slope, its presence is better ignored, probably, except that the increased weight must be considered.

The spandrel wall of an arch may present two of these special cases; i.e., the profile may be enlarged to include a moving load, while it may be limited at the back by the other spandrel.

If the earth profile starts at the front edge of the top of wall, instead of from the back as at B , Fig. 496, eq. (3) would only apply to the portion behind AB prolonged, leaving the part on the wall (top) to be treated as a part of the wall to aid in resisting the thrust.

If the wall is stepped in from the footings, or foundation

courses, probably the weak section will be just above them; if stepped at intervals up the back of the wall, the surface of separation between the wall and filling, if it is plane, will probably pass through the first step and incline forward as much as possible without cutting the wall.

450. **Straight Earth-profile.**—The general case can be simplified as follows (the earth-profile BD being straight, at angle $= \zeta$ with vertical, $= DET$): Since the triangles ABC' and

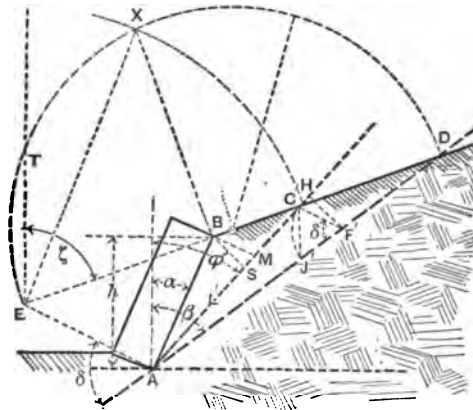

FIG. 499.

$C'AF'$ are equal, from § 447, and AC' is common, therefore $BS = F'H$ (both being drawn \perp to AC'). Draw AE and $BM \parallel$ to $F'C'$ (i.e., at angle δ with AD), cutting DB , prolonged, in E . We have

$$\frac{\overline{DE}}{\overline{C'E}} = \frac{\overline{EA}}{\overline{EA} - \overline{C'F'}}, \text{ and } \frac{\overline{C'E}}{\overline{BE}} = \frac{\overline{EA}}{\overline{EA} - \overline{BM}}.$$

But $C'F' = BM$ (since $\overline{BS} = \overline{H'F'}$);

therefore
$$\frac{\overline{DE}}{\overline{C'E}} = \frac{\overline{C'E}}{\overline{BE}}; \text{ i.e., } \overline{DE} \cdot \overline{BE} = \overline{C'E}^2,$$

which justifies the following construction for locating the desired point C' on BD , and thus finding $\overline{AC'} = L$ and the angle ϕ' : Describe a circle on ED as a diameter, and draw

$BX \perp$ to BD , thus fixing X in the curve. With centre E describe a circular arc through X , cutting BD in C' , required.

Having $\overline{AU'}$ (i.e., L'), ϕ' is known; hence from eq. (3) we obtain the earth thrust or pressure P' : or, with F' as centre and radius = $C'F'$, describe arc $C'J'$; then the triangle $C'F'J'$ is the base of a prism of unity height whose weight = P' (as in § 447).

Centre of Pressure.—Applying the method of § 448, Fig. 498, to this case, we find that the successive L' 's are proportional to the depths ab, ac, ad , etc., and that the successive P' 's are proportional [see (3)] to the squares of the depths; hence the area in Fig. 498 must be triangular in this case, and the point of application of the resultant pressure on AB is one third of AB from A : just as with liquid pressure.

451. Resistance of Retaining Walls.—(Fig. 500.) Knowing the height of the wall we can find its weight, = G , for an assumed thickness, and unity width \perp to paper. The resultant of G , acting through the centre of gravity of wall, and P' , the

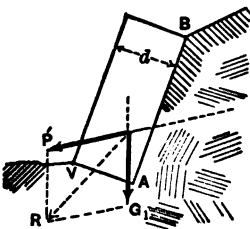

FIG. 500.

thrust of the embankment, in its proper line of action, should cut the base AV within the middle third and make an angle with the normal (to the base) less than the angle of friction.

For the straight wall and straight earth-profile of Fig. 499 and § 450, the length $L' = AC'$, can be expressed in terms of the (vertical) height, h , of wall, thus:

$$\overline{AB} = \frac{h}{\cos \alpha},$$

$$\text{and } L' = \overline{AC'} = \overline{AB} \cdot \frac{\sin(\zeta - \alpha)}{\sin(\zeta - \phi')} = \frac{h}{\cos \alpha} \cdot \frac{\sin(\zeta - \alpha)}{\sin(\zeta - \phi')};$$

\therefore eq. (3) becomes

$$P' = \frac{1}{2} \gamma \frac{h^2}{\cos^2 \alpha} \cdot \frac{\sin^2(\beta - \phi') \sin^2(\zeta - \alpha)}{\sin \delta \sin^2(\zeta - \phi')} = \frac{1}{2} \gamma \frac{h^2}{\cos^2 \alpha} \cdot A. \quad (5)$$

[A representing the large fraction for brevity.]

This equation will require, for a wall of rectangular section, that the thickness, d , increase as h , in order that its weight may increase as h^2 (i.e., as P') and that its resisting moment may increase with the overturning moment.

By this equality of moments is meant that $P'a = G'b$; where a and b are the respective lever-arms of the two forces about the front edge of the middle third. (AB is the back of the wall.) In other words, their resultant will pass through this point.

The following table is computed on the basis just mentioned, viz., that the resultant of P' and G shall pass through the front edge of the middle third.

The symbols of eq. (5) and the table are all shown in Fig. 499, except γ , θ , and δ . γ = weight of a cubic foot of earth, here assumed = $\frac{2}{3}$ that of masonry (e.g., if earth weighs 100 lbs., masonry is assumed to weigh 150 lbs. per cubic foot); θ = angle which the thrust P' makes with the back of the wall; and $\delta = \alpha + \theta$, = θ in this case as the wall is vertical, or $\alpha = 0$. d is the proper safe thickness to be given to the wall, of rectangular section, to prevent overturning, as stated above; h is the altitude, and A is the fraction shown in eq. (5).

Whether the wall is safe against sliding on its base, and whether a safe compression per unit area is exceeded on the front edge of the base, are matters for separate consideration. The latter will seldom govern with ordinary retaining walls.

a = 0; i.e., wall is vertical; also density of wall = $\frac{2}{3}$ that of the earth.										
		I.			II.			III.		
		$\zeta = 90^\circ$ $\theta = 90^\circ$			$\zeta = 90^\circ$ $\theta = \beta$			$\zeta = \beta$		
$\tan \beta$	β	ϕ'	A	d	ϕ'	A	d	ϕ'	A	d
1.0	45°	22½°	.17	.84h	26°	.18	.22h	45°	.71	.83h
1.5	56½°	28°	.29	.44h	33°	.26	.30h	56°	.88	.43h
2.0	63½°	31½°	.38	.51h	38°	.33	.36h	63°	.89	.51h
4.0	76°	38°	.61	.64h	45°	.54	.50h	76°	.97	.65h
Infinity	90°	45°	1.00	.82h	90°	1.00	.82h	90°	1.00	.82h

In Case I of table, since $\alpha = 0$, $\theta = 90^\circ$ and $\zeta = 90^\circ$; $\therefore \delta = 90^\circ$, and hence $C'F'$ of Fig. 499 is \perp to AD , so that

(since the area of $\triangle ABC' = \triangle AC'F'$) ϕ' must = $\frac{1}{2}\beta$. These values, in (5), give

$$P' = \frac{1}{2}\gamma h^2 \tan^2 \frac{1}{2}\beta; \text{ i.e., } A = \tan^2 \frac{1}{2}\beta. \dots (6)$$

In Case II, since $\zeta = 90^\circ$, $\alpha = 0$ and $\theta = \beta$, $\therefore \delta = \beta$; and (5) reduces to

$$P' = \frac{1}{2}\gamma h^2 \frac{\sin^2(\beta - \phi')}{\sin \beta \cos^2 \phi'}; \text{ i.e., } A = \frac{\sin^2(\beta - \phi')}{\sin \beta \cos^2 \phi'}. \dots (7)$$

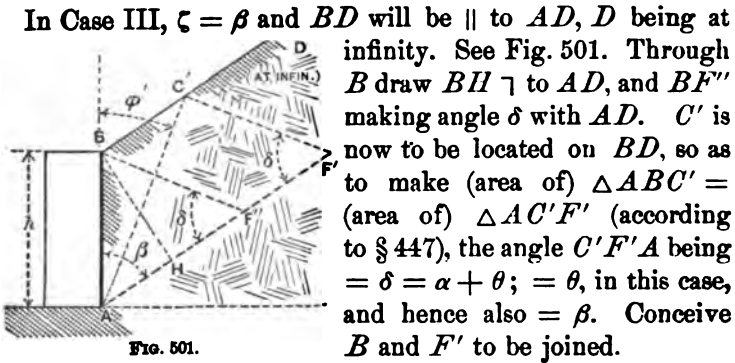

Now $\triangle AC'F' = \triangle ABF'' + \triangle BF'F''$.

But $\triangle ABC' = \triangle BF'F''$ (equal bases and altitudes).

Hence $\triangle ABC'$ cannot = $\triangle AC'F'$ unless C' is moved out to infinity; and then ϕ' becomes = β , and eq. (5) reduces to

$$P' = \frac{1}{2}\gamma h^2 \sin \beta; \text{ i.e., } A = \sin \beta. \dots (8)$$

[Increasing α from zero will decrease the thickness d ; i.e., inclining the wall inwards will decrease the required thickness, but diminish the frictional stability at the base, unless the latter be \perp to AB . The back of the wall is frequently inclined outwards, making the section a trapezoid, to increase the frictional stability at the base when necessary, as with timber walls supporting water.]

452. Practical Considerations. — An examination of the values of A and d in the table of § 451 will show that in supporting quicksand and many kinds of clay which are almost fluid under the influence of water, it is important to know what kind of drainage can be secured, for on that will depend the thickness of the wall. With well compacted material free from water-bearing strata, an assumed natural slope of $1\frac{1}{2}$ to 1 (i.e., $1\frac{1}{2}$ hor. to 1 vert.) will be safe; the actual pressure below the effect of frost and surface water will be that due to a much steeper slope on account of *cohesion* (neglected in this theory).

The thrust from freshly placed material can be reduced by depositing it in layers sloping back from the wall. If it is not so placed, however, the natural slope will seldom be flatter than $1\frac{1}{2}$ to 1 unless reduced by water. In supporting material which contains water-bearing strata sloping toward the wall and overlain by strata which are liable to become semi-fluid and slippery, the thrust may exceed that due to semi-fluid material on account of the surcharge. If these strata are under the wall and cannot be reached by the foundation, or if resistance to sliding cannot be obtained from the material in front by sheet-piling, no amount of masonry can give security.

Water at the back of the wall will, by freezing, cause the material to exert an indefinitely great pressure, besides disintegrating the wall itself. If there is danger of its accumulation, drainage should be provided by a layer of loose stone at the back leading to "weep-holes" through the wall.

A friction-angle at the back of the wall equal to that of the filling should always be realized by making the back rough by steps, or projecting stones or bricks. Its effect on the required thickness is too great to be economically ignored.

The resistance to slipping at the base can be increased, when necessary, by inclining the foundation inwards; by stepping or sloping the back of the wall so as to add to its effective weight or incline the thrust more nearly to the vertical; by sheet-piling in front of the foundation, thus gaining the resistance offered by the piles to lateral motion; by deeper foundations, gaining the resistance of the earth in front of the wall.

The coefficient of friction on the base ranges, according to Trautwine, from 0.20 to 0.30 on wet clay ;
 “ .50 to .66 “ dry earth ;
 “ .66 to .75 “ sand or gravel ;
 “ .60 on a dry wooden platform ; to .75 on a wet one.

If the wall is partially submerged, the buoyant effort should be subtracted from G_1 , the weight of wall.

453. Results of Experience.—(Trautwine.) In railroad practice, a vertical wall of rectangular section, sustaining sand, gravel, or earth, level with the top [p. 682 of Civ. Eng. Pocket Book] and loosely deposited, as when dumped from carts, cars, etc., should have a thickness d , as follows :

If of cut stone, or of first-class large ranged rubble, in mortar. $d = .35d$
 “ good common scabbled mortar-rubble, or brick. $d = .40d$
 “ well scabbled dry rubble. $d = .50d$

Where h includes the total height, or about 3 ft. of foundations.

(a) For the best masonry of its class h may be taken from the top of the foundation in front.

(b) A mixture of sand or earth, with a large proportion of round boulders or cobbles, will weigh more than the backing assumed above ; requiring d to be increased from one eighth to one sixth part.

(c) The wall will be stronger by inclining the back inwards, especially if of dry masonry, or if the backing is put in place before the mortar has set.

(d) The back of the wall should be left rough to increase friction.

(e) Where deep freezing occurs, the back should slope outward for 3 or 4 feet below the top and be left smooth.

(f) When a wall is too thin, it will generally fail by bulging outward at about one third the height. The failure is usually gradual and may take years.

(g) *Counterforts*, or buttresses at the back of the wall, usually of rectangular section, may be regarded as a waste of masonry, although considerably used in Europe ; the bond will

scidom hold them to the wall. Buttresses *in front* add to the strength, but are not common, on account of expense.

(h) *Land-ties* of iron or wood, tying the wall to anchors imbedded below the line of natural slope, are sometimes used to increase stability.

(i) Walls with curved cross-sections are not recommended.

454. Conclusions of Mr. B. Baker.—("Actual Lateral Pressure of Earthwork.") Experience has shown that $d = 0.25h$, with batter of 1 to 2 inches per foot on face, is sufficient when backing and foundation are both favorable; also that under *no* ordinary conditions of surcharge or heavy backing, with solid foundation, is it necessary for d to be greater than $0.50h$.

Mr. Baker's own rule is to make $d = 0.33h$ at the top of the footings, with a face batter of $1\frac{1}{2}$ inches per foot, in ground of average character; and, if any material is taken out to form a face-panel, three fourths of it is put back in the form of a pilaster. The object of the batter, and of the panel if used, is to distribute the pressure better on the foundation. All the walls of the "District Railway" (London) were designed on this basis, and there has not been a single instance of settlement, of overturning, or of sliding forward.

455. Experiments with Models.—Accounts of experiments with apparatus on a small scale, with sand, etc., may be found in vol. LXXI of Proceedings of Institution of Civil Engineers, London, England (p. 350); also in vol. II of the "Annales des Ponts et Chaussées" for 1885 (p. 788).

The results of these experiments, and the results of experience given in §§ 453 and 454, when compared with the table of p. 581, indicate a fairly close agreement between practice and theory. This agreement is believed to be close enough so that the general method of §§ 447 and 451, with the table of p. 581, can be relied upon in practice. The greatest value of this method will, of course, be for cases of exceptional loading, inclined walls, etc., where the results of experience do not furnish so valuable a guide.

CHAPTER IV.

HYDROSTATICS (*Continued*)—IMMERSION AND FLOTATION.

456. Rigid Body Immersed in a Liquid. Buoyant Effort.—If any portion of a body of homogeneous liquid at rest be conceived to become rigid without alteration of shape or bulk, it would evidently still remain at rest; i.e., its weight, applied at its centre of gravity, would be balanced by the pressures, on its bounding surfaces, of the contiguous portions of the liquid; hence,

If a rigid body or solid is immersed in a liquid, both being at rest, the resultant action upon it of the surrounding liquid (or fluid) is a vertical upward force called the "buoyant effort," equal in amount to the weight of liquid displaced, and acting through the centre of gravity of the volume (considered as homogeneous) of displacement (now occupied by the solid). This point is called the centre of buoyancy, and is sometimes spoken of as the centre of gravity of the displaced water. If V' = the volume of displacement, and γ = heaviness of the liquid, then the

$$\text{buoyant effort} = V'\gamma. \quad . \quad . \quad . \quad . \quad . \quad (1)$$

(By "volume of displacement" is meant, of course, the volume of liquid actually displaced when the body is immersed.)

If the weight G' of the solid is not equal to the buoyant effort, or if its centre of gravity does not lie in the same vertical as the centre of buoyancy, the two forces form an unbalanced system and motion begins. But as a consequence of this very motion the action of the liquid is modified in a manner dependent on the shape and kind of motion of the body.

Problems in this chapter are restricted to cases of rest, i.e., balanced forces.

Suppose $G' = V'\gamma$; then,

If the centre of gravity lies in the same vertical line as the centre of buoyancy and *underneath* the latter, the equilibrium is *stable*; i.e., after a slight angular disturbance the body returns to its original position (after several oscillations); while if *above* the latter, the equilibrium is *unstable*. If they *coincide*, as when the solid is homogeneous (but not hollow), and of the same heaviness (§ 7) as the liquid, the equilibrium is *indifferent*, i.e., possible in any position of the body.

The following is interesting in this connection:

In an account of the new British submarine boat "Nautilus," a writer in *Chambers's Journal* remarked [1887]: "At each side of the vessel are four port-holes, into which fit cylinders two feet in diameter. When these cylinders are projected outwards, as they can be by suitable gearing, the displacement of the boat is so much increased that the vessel rises to the surface; but when the cylinders are withdrawn into their sockets, it will sink."

As another case in point, large water-tight canvas "air-bags" have recently been used for raising sunken ships. They are sunk in a collapsed state, attached by divers to the submerged vessel, and then inflated with air from pumps above, which of course largely augments their displacement while adding no appreciable weight.

457. Examples of Immersion.—Fig. 502. At (a) is an example of stable equilibrium, the centre of buoyancy B being above the centre of gravity C , and the buoyant effort $V'\gamma = G' =$ the weight of the solid; at (a'), conversely, we have unstable equilibrium, with

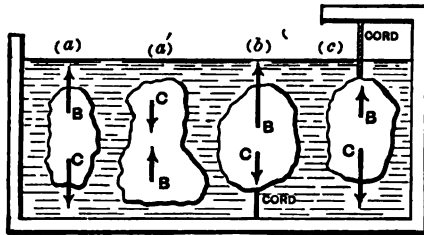

FIG. 502;

$V'\gamma$ still $= G'$. At (b) the buoyant effort $V'\gamma$ is $> G'$, and

to preserve equilibrium the body is attached by a cord to the bottom of the vessel. The tension in this cord is

$$S_b = V'\gamma - G'. \quad \dots \quad (1)$$

At (c) $V'\gamma$ is $< G'$, and the cord must be attached to a support above, and its tension is

$$S_o = G' - V'\gamma. \quad \dots \quad (2)$$

If in eq. (2) [(c) in figure] we call S_o the *apparent weight* of the immersed body, and measure it by a spring- or beam-balance, we may say that

The apparent weight of a solid totally immersed in a liquid equals its real weight diminished by that of the amount of liquid displaced; in other words, the loss of weight = the weight of displaced liquid.

EXAMPLE 1.—How great a mass (not hollow) of cast-iron can be supported in water by a wrought-iron cylinder weighing 140 lbs., if the latter contains a vacuous space and displaces 3 cub. feet of water, both bodies being completely immersed? [Ft., lb., sec.]

The buoyant effort on the cylinder is

$$V'\gamma = 3 \times 62.5 = 187.5 \text{ lbs.},$$

leaving a residue of 47.5 lbs. upward force to buoy the cast-iron, whose volume V'' is unknown, while its heaviness (§ 7) is $\gamma'' = 450$ lbs. per cub. foot. The direct buoyant effort of the water on the cast-iron is $V''\gamma = [V'' \times 62.5]$ lbs., and the problem requires that this force + 47.5 lbs. shall = $V''\gamma'' =$ the weight G'' of the cast-iron;

$$\therefore V'' \times 62.5 + 47.5 = V'' \times 450;$$

$$\therefore V'' = 0.12 \text{ cub. ft.}, \text{ while } 0.12 \times 450 = 54 \text{ lbs. of cast-iron.}$$

Ans.

EXAMPLE 2.—Required the volume V' , and heaviness γ' , of a *homogeneous* solid which weighs 6 lbs. out of water and 4 lbs. when immersed (*apparent weight*) (ft., lb., sec).

From eq. (2), $4 = 6 - V' \times 62.5$; $\therefore V' = 0.032$ cub. feet;

$$\therefore \gamma' = G' \div V' = 6 \div 0.032 = 187.5 \text{ lbs. per cub. ft.,}$$

and the ratio of γ' to γ is $187.5 : 62.5 = 3.0$ (abstract number); i.e., the substance of this solid is three times as dense, or three times as heavy, as water. [The buoyant effort of the air has been neglected in giving the true weight as 6 lbs.]

456. Specific Gravity.—By *specific gravity* is meant the ratio of the heaviness of a given homogeneous substance to that of a standard homogeneous substance; in other words, the ratio of the weight of a certain volume of the substance to the weight of an *equal* volume of the standard substance. Distilled water at the temperature of maximum density (4° Centigrade) under a pressure of 14.7 lbs. per sq. inch is sometimes taken as the standard substance, more frequently, however, at 62° Fahrenheit (16.6 Centigrade). Water, then, being the standard substance, the numerical example last given illustrates a common method of determining experimentally the specific gravity of a homogeneous solid substance, the value there obtained being 3. The symbol σ will be used to denote specific gravity, which is evidently an abstract number. The standard substance should always be mentioned, and its heaviness γ ; then the heaviness of a substance whose specific gravity is σ is

$$\gamma' = \sigma\gamma, \quad \dots \dots \dots (1)$$

and the weight G' of any volume V' of the substance may be written

$$G' = V'\gamma' = V'\sigma\gamma. \quad \dots \dots \dots (2)$$

Evidently a knowledge of the value of γ' dispenses with the use of σ , though when the latter can be introduced into problems involving the buoyant effort of a liquid the criterion as to whether a *homogeneous* solid will sink or rise, when immersed in the *standard* liquid, is more easily applied, thus: Being immersed, the volume V' of the body = that, V , of displaced liquid. Hence,

if G' is $> V'\gamma$, i.e., if $V'\gamma'$ is $> V'\gamma$, or $\sigma > 1$, it sinks ;
 while if G' is $< V'\gamma$, ; or $\sigma < 1$, it rises ;

i.e., according as the weight G' is $>$ or $<$ than the buoyant effort.

Other methods of determining the specific gravity of solids, liquids, and gases are given in works on Physics.

459. Equilibrium of Flotation.—In case the weight G' of an immersed solid is less than the buoyant effort $V'\gamma$ (where V' is the volume of displacement, and γ the heaviness of liquid) the body rises to the surface, and after a series of oscillations comes to rest in such a position, Fig. 503, that its centre of gravity C and the centre of buoyancy B (the new B , belonging to the new volume of displacement, which is limited above by the horizontal plane of the free surface of the liquid) are in the same vertical (called the axis of flotation, or line of support), and that the volume of displacement has diminished to such a new value V , that

$$V\gamma = G'. \quad (1)$$

In the figure, $V = \text{vol. } AND$, below the horizontal plane AN , and the slightest motion of the body *will change the form of this volume*, in general (whereas with complete immersion the volume of displacement remains constant). For stable equilibrium it is not essential in every case that C (centre of gravity of body) should be below B (the centre of buoyancy) as with complete immersion, since if the solid is turned, B may change its position in the body, as the form of the volume AND changes.

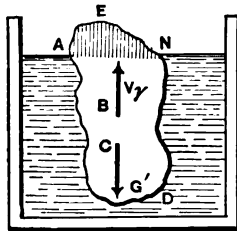

FIG. 503.

There is now no definite relation between the volume of displacement V and that of the body, V' , unless the latter is *homogeneous*, and then for G' we may write $V'\gamma'$, i.e.

$$V'\gamma' = V\gamma \text{ (for a homogeneous solid) ; } . . (2)$$

or, *the volumes are inversely proportional to the heavinesses.*

The buoyant effort of the air on the portion ANE may be neglected in most practical cases, as being insignificant.

If the solid is *hollow*, the position of its centre of gravity C may be easily varied (by shifting ballast, e.g.) within certain limits, but that of the centre of buoyancy B depends only on the geometrical form of the volume of displacement AND , below the horizontal plane AN .

EXAMPLE.—(Ft., lb., sec.) Will a solid weighing $G' = 400$ lbs., and having a volume $V' = 8$ cub. feet, without hollows or recesses, float in water? To obtain a buoyant effort of 400 lbs., we need a volume of displacement, see eq. (1), of

$$V = \frac{G'}{\gamma} = \frac{400}{62.5} = \text{only } 6.4 \text{ cub. ft.}$$

Hence the solid will float with $8 - 6.4$, or 1.6, cub. ft. projecting above the water level.

Query: A vessel contains water, reaching to its brim, and also a piece of ice which floats without touching the vessel. When the ice melts will the water overflow?

460. The Hydrometer is a floating instrument for determining the relative heavinesses of liquids. Fig. 504 shows a simple form, consisting of a bulb and a cylindrical stem of glass, so designed and weighted as to float upright in all liquids whose heavinesses it is to compare. Let F denote the uniform sectional area of the stem (a circle), and suppose that when floating in water (whose heaviness = γ) the water surface marks a point A on the stem; and that when floating in another liquid, say petroleum, whose heaviness, = γ_p , we wish to determine, it floats at a greater depth, the liquid surface now marking A' on the stem, a height = x above A . G' is the same in both experiments; but while the volume of displacement in water is V , in petroleum it is $V + Fx$. Therefore from eq. (1), § 459,

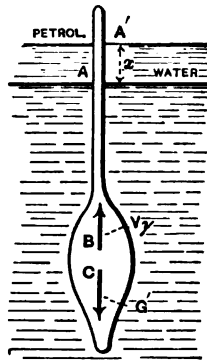

FIG. 504.

$$\text{in the water} \quad G' = V\gamma, \quad (1)$$

$$\text{and} \quad \text{in the petroleum} \quad G' = (V + Fx)\gamma_p; \quad . . (2)$$

from which, knowing G' , F , x , and γ , we find V and γ_p , i.e.,

$$V = \frac{G'}{\gamma} \quad \text{and} \quad \gamma_p = \frac{G'\gamma}{G' + Fxy}. \quad . . . (3)$$

[N.B.— F is best determined by noting the additional distance, $= l$, through which the instrument sinks in water under an additional load P , *not immersed*; for then

$$G' + P = (V + Fl)\gamma, \quad \text{or} \quad F = \frac{P}{l\gamma}.]$$

EXAMPLE.—[Using the *inch*, *ounce*, and *second*, in which system $\gamma = 1000 \div 1728 = 0.578$ (§ 409).] With $G' = 3$ ounces, and $F = 0.10$ sq. inch, x being observed, on the graduated stem, to be 5 inches, we have for the petroleum

$$\begin{aligned} \gamma_p &= \frac{3 \times 0.578}{3 + 0.10 \times 5 \times 0.578} = 0.525 \text{ oz. per cubic inch} \\ &= 56.7 \text{ lbs. per cub. foot.} \end{aligned}$$

Temperature influences the heaviness of most liquids to some extent.

In another kind of instrument a scale-pan is fixed to the top of the stem, and the specific gravity computed from the weight necessary to be placed on this pan to cause the hydrometer to sink to the *same* point in *all* liquids for which it is used.

461. Depth of Flotation.—If the weight and external shape of the floating body are known, and the centre of gravity so situated that the position of flotation is known, the *depth of the lowest point below the surface may be determined.*

CASE I. *Right prism or cylinder with its axis vertical.*—
 Fig. 505. (For stability in this position, see § 464a.) Let G' = weight of cylinder, F' the area of its cross-section (full circle), h' its altitude, and h the unknown depth of flotation (or draught); then from eq. (1), § 426,

$$G' = Fh\gamma; \therefore h = \frac{G'}{F\gamma}; \dots (1)$$

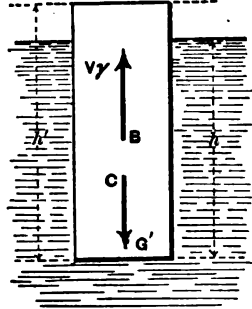

FIG. 505.

in which γ = heaviness of the liquid. If the prism (or cylinder) is *homogeneous* (and then C , at the middle of h' , is higher than B) and γ' its heaviness, we then have

$$h = \frac{Fh'\gamma'}{F'\gamma} = \frac{\gamma'h'}{\gamma} = \sigma h'; \dots (2)$$

in which σ = specific gravity of solid referred to the liquid as standard. (See § 458.)

CASE II. *Pyramid or cone with axis vertical and vertex down.*—Fig. 506. Let V' = volume of whole pyramid (or cone), and V = volume of displacement. From similar pyramids,

$$\frac{V}{V'} = \frac{h^3}{h'^3}; \therefore h = \sqrt[3]{\frac{V}{V'}} \cdot h'.$$

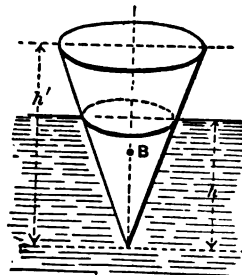

FIG. 506.

But $G' = V\gamma$; or, $V = \frac{G'}{\gamma}$; whence

$$h = h' \sqrt[3]{\frac{G'}{V'\gamma}} \dots (3)$$

CASE III. *Ditto, but vertex up.*—Fig. 507. Let the notation be as before, for V and V' . The part out of water is a pyramid of volume $= V'' = V' - V$, and is similar to the whole pyramid;

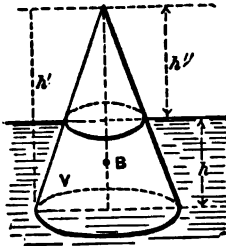

FIG. 507.

$$\therefore V' - V : V' :: h''^3 : h'^3.$$

Also, $V = \frac{G'}{\gamma}$;

$$\therefore h'' = h' \sqrt[3]{\frac{V' - V}{V'}} = h' \sqrt[3]{\frac{V'\gamma - G'}{V'\gamma}};$$

$$\therefore, \text{ finally, } h = h' \left[1 - \sqrt[3]{1 - [G' \div V'\gamma]} \right]. \dots (4)$$

CASE IV. *Sphere.*—Fig. 508. The volume immersed is

$$V = \int_{z=0}^{z=h} (\pi x^2) dz = \pi \int_0^h (2rz - z^2) dz = \pi h^2 \left[r - \frac{h}{3} \right];$$

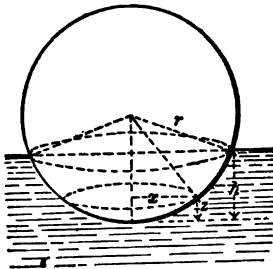

FIG. 508.

and hence, since $V\gamma = G' = \text{weight of sphere}$,

$$\pi r h^2 - \frac{\pi h^3}{3} = \frac{G'}{\gamma} \dots (5)$$

From which cubic equation h may be obtained by successive trials and approximations.

[An exact solution of (5) for the unknown h is impossible, as it falls under the irreducible case of Cardan's Rule.]

CASE V. *Right cylinder with axis horizontal.*—Fig. 509.

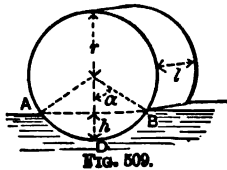

FIG. 509.

$$\text{Vol. im-} \\ \text{mers.} = V \left. \vphantom{\text{Vol. im-}} \right\} = [\text{area of seg. } ADB] \times l \\ = (r^2\alpha - \frac{1}{2}r^2 \sin 2\alpha)l;$$

hence, since $V = \frac{G'}{\gamma}$,

$$lr^2[\alpha - \frac{1}{2} \sin 2\alpha] = \frac{G'}{\gamma} \dots (6)$$

From this transcendental equation we can obtain α , by trial, in *radians* (see example in § 428), and finally h , since

$$h = r(1 - \cos \alpha). \dots \dots \dots (7)$$

EXAMPLE 1.—A sphere of 40 inches diameter is observed to have a depth of flotation $h = 9$ in. in water. Required its weight G' . From eq. (5) (inch, lb., sec.) we have

$$G' = [62.5 \div 1728]\pi 9^3[20 - \frac{1}{3} \times 9] = 156.5 \text{ lbs.}$$

The sphere may be hollow, e.g., of sheet metal loaded with shot; constructed in any way, so long as G' and the volume V of displacement remain unchanged. But if the sphere is *homogeneous*, its heaviness (§ 7) γ' must be

$$\begin{aligned} &= G' \div V' = G' \div \frac{4}{3}\pi r^3 = (156.5) \div \frac{4}{3}\pi 20^3 \\ &= .00466 \text{ lbs. per cubic inch,} \end{aligned}$$

and hence, referred to water, its specific gravity is $\sigma =$ about 0.13.

EXAMPLE 2.—The right cylinder in Fig. 509 is homogeneous and 10 inches in diameter, and has a specific gravity (referred to water) of $\sigma = 0.30$. Required the depth of flotation h .

Its heaviness must be $\gamma' = \sigma\gamma$; hence its weight

$$G' = V'\sigma\gamma = \pi r^2 l \sigma \gamma;$$

hence, from eq. (6),

$$r^2 l [\alpha - \frac{1}{2} \sin 2\alpha] = \pi r^2 l \sigma, \therefore \alpha - \frac{1}{2} \sin 2\alpha = \pi \sigma$$

(involving abstract numbers only). Trying $\alpha = 60^\circ (= \frac{1}{2}\pi$ in *radians*), we have

$$\frac{1}{2}\pi - \frac{1}{2} \sin 120^\circ = 0.614; \text{ whereas } \pi \sigma = .9424$$

For $\alpha = 70^\circ$, $1.2217 - \frac{1}{2} \sin 140^\circ = 0.9003$;

For $\alpha = 71^\circ$, $1.2391 - \frac{1}{2} \sin 142^\circ = 0.9313$;

For $\alpha = 71^\circ 22'$, $1.2455 - \frac{1}{2} \sin 142^\circ 44' = 0.9428$, which may be considered sufficiently close. Now from eq. (7),

$$h = (5 \text{ in.}) (1 - \cos 71^\circ 22') = 3.40 \text{ in.} \text{—Ans.}$$

462. Draught of Ships.—In designing a ship, especially if of a new model, the position of the centre of gravity is found by eq. (3) of § 23 (with weights instead of volumes); i.e., the sum of the products obtained by multiplying the weight of each portion of the hull and cargo by the distance of its centre of gravity from a convenient reference-plane (e.g., the horizontal plane of the keel bottom) is divided by the sum of the weights, and the quotient is the distance of the centre of gravity of the whole from the reference-plane.

Similarly, the distance from another reference-plane is determined. These two co-ordinates and the fact that the centre of gravity lies in the median vertical plane of symmetry of the ship (assuming a symmetrical arrangement of the framework and cargo) fix its location. The total weight, G' , equals, of course, the sum of the individual weights just mentioned. The *centre of buoyancy*, for any assumed draught and corresponding position of ship, is found by the same method; but more simply, since it is the centre of gravity of the imaginary homogeneous volume between the water-line plane and the *wetted* surface of the hull. This volume (of "displacement") is divided into an even number (say 4 to 8) of horizontal laminae of *equal thickness*, and Simpson's Rule applied to find the volume (i.e., the V of preceding formulæ), and also (eq. 3, § 23) the height of its centre of gravity above the keel. Similarly, by division into (from 8 to 20) vertical slices, γ to keel (an even number and of *equal thickness*), we find the distance of the centre of gravity from the bow. Thus the centre of buoyancy is fixed, and the corresponding buoyant effort $V\gamma$ (technically called the *displacement* and usually expressed in tons) computed, for any assumed draught of ship (upright). That position in which the "displacement" = G' = weight of ship is the position of equilibrium of the ship when floating upright in still water, and the corresponding draught is noted. As to whether this equilibrium is stable or unstable, the following will show.

In most ships the centre of gravity C is several feet above the centre of buoyancy, B , and a foot or more below the water line.

After a ship is afloat and its draught actually noted its total weight $G', = V\gamma$, can be computed, the values of V for different draughts having been calculated in advance. In this way the weights of different cargoes can also be measured.

EXAMPLE.—A ship having a displacement of 5000 tons is itself 5000 tons in weight, and displaces a volume of *salt* water $V = G' \div \gamma = 10,000,000 \text{ lbs.} \div 64 \text{ lbs. per cub. ft.} = 156250 \text{ cub. ft.}$

463. Angular Stability of Ships.—If a vessel floating upright were of the peculiar form and position of Fig. 510 (the water-line section having an area = zero) its tendency to regain that position, or depart from it, when slightly inclined an angle ϕ from the vertical is due to the action of the couple now formed by the equal and parallel forces $V\gamma$ and G' , which are no longer directly opposed. This couple is called a *righting couple* if it acts to restore the first position (as in Fig. 511, where C is lower than B), and an *upsetting couple* if the reverse, C above B . In either case the moment of the couple is

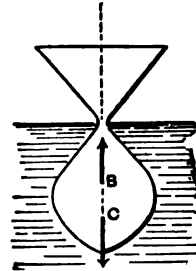

FIG. 510.

$$= V\gamma \cdot \overline{BC} \sin \phi = V\gamma e \sin \phi,$$

and the centre of buoyancy B does not change its position in the vessel, since the water-displacing shape remains the same; i.e., no new portions of the vessel are either immersed or raised out of the water.

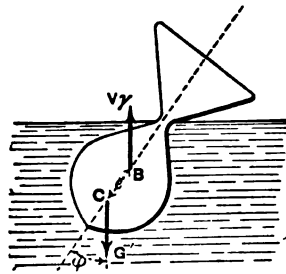

FIG. 511.

But in a vessel of ordinary form, when turned an angle ϕ from the vertical, Fig. 512 (in which ED is a line which is vertical when the ship is upright), there is a *new* centre of buoyancy, B_1 , corresponding to the new shape A_1N_1D of the displacement-volume, and the couple to right the vessel (or the reverse)

consists of the two forces G' at C and $V\gamma$ at B_1 , and has a moment (which we may call M , or *moment of stability*) of a value (§ 28)

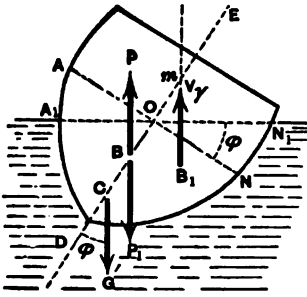

FIG. 512.

$$M = V\gamma \cdot \overline{mC} \sin \phi. \quad \dots (1)$$

Now conceive put in at B (centre of buoyancy of the upright position) two vertical and opposite forces, each = $V\gamma = G'$, calling them P and P_1 (see § 20), Fig. 512.

We can now regard the couple $[G', V\gamma]$ as replaced by the two couples $[G', P]$ and $[P_1, V\gamma]$; for evidently

$$V\gamma \cdot \overline{mC} \sin \phi = V\gamma \cdot \overline{BC} \sin \phi + V\gamma \cdot \overline{mB} \sin \phi;$$

(§§ 33 and 34;)

$$\therefore M = V\gamma \overline{BC} \sin \phi + V\gamma \overline{mB} \sin \phi. \quad \dots (2)$$

But the couple $[G', P]$ would be the only one to right the vessel if no new portions of the hull entered the water or emerged from it, in the inclined position; hence the other couple $[P_1, V\gamma]$ owes its existence to the emersion of the wedge AOA_1 , and the immersion of the wedge NON_1 ; i.e., to the loss of a buoyant force $Q = (\text{volume } AOA_1) \times \gamma$ on one side, and the gain of an equal buoyant force on the other; therefore this couple $[P_1, V\gamma]$ is the equivalent of the couple $[Q, Q]$, Fig. 513, formed by putting in at the centre of buoyancy of each of the two wedges a vertical force

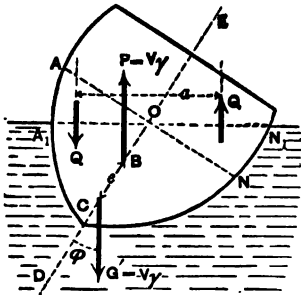

FIG. 513.

$$Q = (\text{vol. of wedge}) \times \gamma = V_w \gamma. \quad (\text{See figure.})$$

If a denotes the arm of this couple, we may write

$$V\gamma \cdot \overline{mB} \sin \phi, [\text{of eq. (2)}], = V_w \gamma a; \dots (3)$$

and hence, denoting \overline{BC} by e , we have

$$M = \pm V\gamma e \sin \phi + V_w \gamma a; \dots (4)$$

the negative sign in which is to be used when C is above B (as with most ships). O , the intersection of ED and AN , does not necessarily lie on the new water-line plane A_1N_1 .

EXAMPLE.—If a ship of ($V\gamma =$) 3000 tons displacement with C 4 ft. above B (i.e., $e = -4$ ft.) is deviated 10° from the vertical, in salt water, for which angle the wedges AOA_1 and NON_1 have each a volume of 4000 cubic feet, while the horizontal distance a between their centres of buoyancy is 18 feet, the moment of the acting couple will be, from eq. (4) (ft.-ton-sec. system, in which γ of salt water = 0.032),

$$M = -3000 \times 4 \times 0.1736 + 4000 \times 0.032 \times 18 = 220.8 \text{ ft. tons,}$$

which being $+$ indicates a *righting* couple.

464. Remark.—If with a given ship and cargo this moment of stability, M , be computed, by eq. (4), for a number of values of ϕ , and the results plotted as ordinates (to scale) of a curve, ϕ being the abscissa, the curve obtained is indicative of the general stability of the ship. See Fig. 514. For some value of $\phi = OK$ (as well as for $\phi = 0$) the value of M is zero, and for $\phi > OK$, M is negative, indicating an *upsetting* couple.

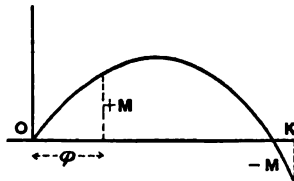

FIG. 514.

That is, for $\phi = 0$ the equilibrium is stable, but for $\phi = OK$, *unstable*; and $M = 0$ in both positions. From eq. (4) we see why, if C is above B , instability does not necessarily follow.

464a. Metacentre of a Ship.—Referring again to Fig. 512, we note that the entire couple [G' , $V\gamma$] will be a righting couple, or an upsetting couple, according as the point m (the

intersection of the vertical through B_1 , the new centre of buoyancy, with BC prolonged) is above or below the centre of gravity C of the ship. The location of this point m changes with ϕ ; but as ϕ becomes very small (and ultimately zero) m approaches a definite position on the line DE , though not occupying it exactly till $\phi = 0$. This limiting position of m is called the *metacentre*, and accordingly the following may be stated: *A ship floating upright is in stable equilibrium if its metacentre is above its centre of gravity; and vice versa.* In other words, for a slight inclination from the vertical a righting, and not an upsetting, couple is called into action, if m is above C . To find the metacentre, by means of the distance \overline{Bm} , we have, from eq. (3),

$$\overline{mB} = \frac{V_w \gamma a}{V \gamma \sin \phi}, \dots \dots \dots (5)$$

and wish ultimately to make $\phi = 0$. Now the moment $(V_w \gamma)a$ = the sum of the moments about the horizontal fore-and-aft water-line axis OL , Fig. 515, of the buoyant efforts

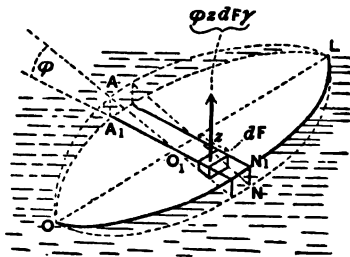

FIG. 515.

due to the immersion of the separate vertical elementary prisms of the wedge OLN_1N , plus the moments of those lost, from emersion, in the wedge OLA_1A . Let OA_1LN_1 be the new water-line section of the ship when inclined a small angle ϕ from the vertical ($\phi = NO_1N_1$), and $OALN$ the old water-line. Let z = the distance of any elementary area dF of the water-line section from OL (which is the intersection of the two water-line planes). Each dF is the base of an elementary prism, with altitude = ϕz , of the wedge N_1OLN (or of wedge A_1OLA when z is negative). The buoyant effort of this prism = (its vol.) $\times \gamma = \gamma z \phi dF$, and its moment about OL is $\phi \gamma z^2 dF$. Hence the total moment, = Qa , or $V_w \gamma a$, of Fig. 513,

$$= \phi \gamma \int z^2 dF = \gamma \phi \times I_{OL}$$

of water-line section, in which I_{OL} denotes the "moment of inertia" (§ 85) of the plane figure $OALNO$ about the axis OL . Hence from (5), putting $\phi = \sin \phi$ (true when $\phi = 0$), we have $\overline{mB} = I_{OL} \div V$; and therefore the distance \overline{mC} , of the metacentre m above C , the centre of gravity of the ship, Fig. 512, is

$$\overline{mC} = h_m = \frac{I_{OL} \text{ (of water-line sec.)}}{V} \pm e, \dots (6)$$

in which $e = BC =$ distance from the centre of gravity to the centre of buoyancy, the negative sign being used when C is above B ; while $V =$ whole volume of water displaced by the ship.

We may also write, from eqs. (6) and (1), for *small values of ϕ* ,

$$\text{Mom. of righting couple} = M = V\gamma \sin \phi \left[\frac{I_{OL}}{V} \pm e \right], \dots (7)$$

or

$$M = \gamma \sin \phi [I_{OL} \pm Ve]. \dots (7')$$

Eqs. (7) and (7') will give close approximations for $\phi < 10^\circ$ or 15° with ships of ordinary forms.

EXAMPLE 1. — A homogeneous right parallelepiped, of heaviness γ' , floats upright as in Fig. 516. Find the distance $mC = h_m$ for its metacentre in this position, and whether the equilibrium is stable. Here the centre of gravity, C , being the centre of figure, is of course above B , the centre of buoyancy; hence e is *negative*. B is the centre of gravity of the displacement, and is therefore a distance $\frac{1}{2}h$ below the water-line. We here assume that l is greater than b' . From eq. (2), § 461,

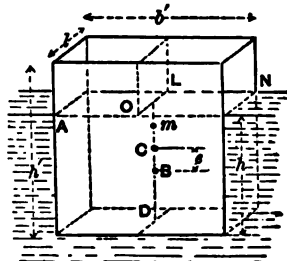

FIG. 516.

$$h = \frac{h'\gamma'}{\gamma};$$

and since $CD = \frac{1}{2}h'$, and $BD = \frac{1}{2}h$, $\therefore e = \frac{1}{2}(h' - h)$;

$$\text{i.e., } e = \frac{1}{2}h' \left[1 - \frac{\gamma'}{\gamma} \right];$$

while (§ 90) I_{OL} , of the water-line section AN , = $\frac{1}{12}Vb'^2$.

Also,

$$V = b'h' = b'V'h' \frac{\gamma'}{\gamma};$$

and hence, from eq. (6), we have

$$h_m = \frac{Vb'^2\gamma}{12b'h'V'\gamma'} - \frac{1}{2}h' \left[1 - \frac{\gamma'}{\gamma} \right] = \frac{\gamma}{12h'\gamma'} \left[b'^2 - 6h'^2\frac{\gamma'}{\gamma} \left(1 - \frac{\gamma'}{\gamma} \right) \right]$$

Hence if b'^2 is $> 6h'^2 \frac{\gamma'}{\gamma} \left(1 - \frac{\gamma'}{\gamma} \right)$, the position in Fig. 516 is one of stable equilibrium, and *vice versa*. E.g., if $\gamma' = \frac{1}{2}\gamma$, $b' = 12$ inches and $h' = 6$ inches, we have (inch, pound, sec.)

$$h_m = \overline{mC} = \frac{1}{8} [144 - 6 \times \frac{2}{1}(1 - \frac{1}{2})] = 2.5 \text{ in.}$$

The equilibrium will be unstable if, with $\gamma' = \frac{1}{2}\gamma$, b' is made less than $1.225 h'$; for, putting $\overline{mC} = 0$, we obtain $b' = 1.225 h'$.

EXAMPLE 2.—(Ft., lb., sec.) Let Fig. 517 represent the *half* water-line section of a loaded ship of $G' = V\gamma = 1010$ tons

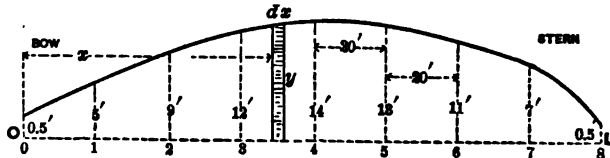

FIG. 517.

displacement; required the height of the metacentre above the centre of buoyancy, i.e., $\overline{mB} = ?$ (See equation just before eq. (6).) Now the quantity I_{OL} , of the water-line section, may, from symmetry, (see § 93,) be written

$$I_{OL} = 2 \int_0^L \frac{1}{12} y^3 dx, \dots \dots (1)$$

in which y = the ordinate γ to the axis OL at any point; and this, again, by Simpson's Rule for approximate integration, OL being divided into an even number, n , of equal parts, and ordinates erected (see figure), may be written

$$I_{OL} = \frac{2}{3} \cdot \frac{\overline{OL} - 0}{3n} \left[y_0^3 + 4(y_1^3 + y_3^3 + \dots + y_{n-1}^3) + 2(y_2^3 + y_4^3 + \dots + y_{n-2}^3) + y_n^3 \right].$$

From which, by numerical substitution (see figure for dimensions; $n = 8$),

$$I_{OL} = \frac{2}{3} \cdot \frac{160}{3 \times 8} \left[(0.5^3 + 4(5^3 + 12^3 + 13^3 + 7^3) + 2(9^3 + 14^3 + 11^3) + 0.5^3) \right];$$

	125	
	1728	729
or,	2197	2744
	343	1331

$$I_{OL} = 4\frac{2}{3} [0.125 + 4 \times 4393 + 2 \times 4804 + 0.125]$$

$$= 120801 \text{ biquad. ft.}; \therefore \overline{mB} = \frac{I_{OL}}{V} = \frac{120801}{[2020000 \div 64]}$$

$$= 3.8 \text{ feet.}$$

That is, the metacentre is 3.8 feet above the centre of buoyancy, and hence, if $BC = 2$ feet, is 1.90 ft. above the centre of gravity. [See Johnson's Cyclopædia, article *Naval Architecture*.]

465. Metacentre for Longitudinal Stability.—If we consider the stability of a vessel with respect to pitching, in a manner similar to that just pursued for rolling, we derive the position of the metacentre for *pitching* or for longitudinal stability—and this of course occupies a much higher position than that for *rolling*, involving as it does the moment of inertia of the water-line section about a horizontal gravity axis γ to the keel. With this one change, eq. (6) holds for this case also. In large ships the height of this metacentre above the centre of gravity of the ship may be as great as 90 feet.

CHAPTER V.

HYDROSTATICS (*Continued*)—GASEOUS FLUIDS.

466. Thermometers.—The temperature, or “hotness,” of liquids has, within certain limits, but little influence on their statical behavior, but with gases must always be taken into account, since the three quantities, *tension*, *temperature*, and *volume*, of a given mass of gas are connected by a nearly invariable law, as will be seen.

An *air-thermometer*, Fig. 518, consists of a large glass bulb filled with air, from which projects a fine straight tube of

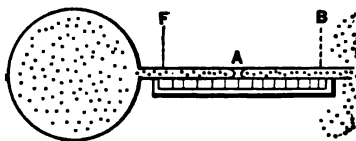

FIG. 518.

even bore (so that equal lengths represent equal volumes). A small drop of liquid, *A*, separates the internal from the external air, both of which are at a tension of (say) one atmosphere (14.7 lbs. per sq. inch). When the bulb is placed in melting ice (freezing-point) the drop stands at some point *F* in the tube; when in boiling water (boiling under a pressure of one atmosphere), the drop is found at *B*, on account of the expansion of the internal air under the influence of the heat imparted to it. (The glass also expands, but only about $\frac{1}{17}$ as much; this will be neglected.) The distance *FB* along the tube may now be divided into a convenient number of equal parts called degrees. If into one hundred degrees, it is found that each degree represents a volume equal to the $\frac{3.67}{10000}$ (.00367) part of the total volume occupied by the air at freezing-point; i.e., the increase of volume from the temperature of freezing-point to that of the boiling-point of water = 0.367 of the volume at freezing, *the pressure being the same*, and even having *any value whatever* (as well as one atmosphere), within ordinary limits, so long as it is the same both at freezing and boil-

ing. It must be understood, however, that by *temperature of boiling* is always meant that of water boiling under *one* atmosphere pressure. Another way of stating the above, if one hundred degrees are used between freezing and boiling, is as follows: That for each degree increase of temperature the increase of volume is $\frac{1}{273}$ of the total volume at freezing; 273 being the reciprocal of .00367.

As it is not always practicable to preserve the pressure constant under all circumstances with an air-thermometer, we use the common mercurial thermometer for most practical purposes. In this, the tube is sealed at the outer extremity, with a vacuum above the column of mercury, and its indications agree very closely with those of the air-thermometer. That equal absolute increments of volume should imply equal increments of heat imparted to these thermometric fluids (under constant pressure) could not reasonably be asserted without satisfactory experimental evidence. This, however, is not altogether wanting, so that we are enabled to say that within a moderate range of temperature equal increments of heat produce equal increments of volume in a given mass not only of atmospheric air, but of the so-called "perfect" or "permanent" gases, oxygen, nitrogen, hydrogen, etc. (so named before it was found that they could be liquefied). This is nearly true for mercury also, and for alcohol, *but not for water*. Alcohol has never been frozen, and hence is used instead of mercury as a thermometric substance to measure temperatures below the freezing-point of the latter.

The scale of a mercurial thermometer is fixed; but with an air-thermometer we should have to use a new scale, and in a new position on the tube, for each value of the pressure.

467. Thermometric Scales.—In the *Fahrenheit* scale the tube between freezing and boiling is marked off into 180 equal parts, and the zero placed at 32 of these parts below the freezing-point, which is hence $+32^{\circ}$, and the boiling-point $+212^{\circ}$.

The *Centigrade*, or *Celsius*, scale, which is the one chiefly used in scientific practice, places its zero at freezing, and 100° at boiling-point. Hence to reduce

Fahr. readings to Centigrade, subtract 32° and multiply by $\frac{5}{9}$;
 Cent. " " Fahrenheit, multiply by $\frac{9}{5}$ and add 32° .

468. Absolute Temperature.—Experiment also shows that if a mass of air or other perfect gas is confined in a vessel whose volume is but slightly affected by changes of temperature, equal increments of temperature (and therefore equal increments of heat imparted to the gas, according to the preceding paragraph) produce equal increments of tension (i.e., pressure per unit area); or, as to the amount of the increase, that when the temperature is raised by an amount 1° Centigrade, the tension is increased $\frac{1}{273}$ of its value at freezing-point. Hence, theoretically, an ideal barometer (containing a liquid unaffected by changes of temperature) communicating with the confined gas (whose *volume* practically remains constant) would by

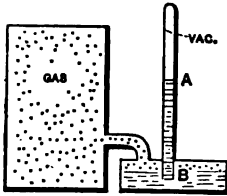

FIG. 519.

its indications serve as a thermometer, Fig. 519, and the attached scale could be graduated accordingly. Thus, if the column stood at *A* when the temperature was freezing, *A* would be marked 0° on the Centigrade system, and the degree spaces above and below *A* would each $= \frac{1}{273}$ of the height *AB*, and therefore the point *B* (cistern level) to which the column would sink if the gas-tension were zero would be marked -273° Centigrade.

But a zero-pressure, in the *Kinetic Theory of Gases* (§ 408), signifies that the gaseous molecules, no longer impinging against the vessel walls (so that the press. = 0), have become motionless; and this, in the *Mechanical Theory of Heat*, or *Thermodynamics*, implies that *the gas is totally destitute of heat*. Hence this ideal temperature of -273° Centigrade, or -460° Fahrenheit, is called the *Absolute Zero of Temperature*, and by reckoning temperatures from it as a starting-point, our formulæ will be rendered much more simple and compact. Temperature so reckoned is called *absolute temperature*, and will be denoted by the letter *T*. Hence the following rules for reduction :

Absol. temp. T in Cent. degrees = Ordinary Cent. + 273° ;

Absol. temp. T in Fahr. degrees = Ordinary Fahr. + 460°.

For example, for 20° Cent., $T = 293^\circ$ Abs. Cent.

469. Distinction Between Gases and Vapors.—All known gases can be converted into liquids by a sufficient reduction of temperature or increase of pressure, or both ; some, however, with great difficulty, such as atmospheric air, oxygen, hydrogen, nitrogen, etc., these having been but recently (1878) reduced to the liquid form. A *vapor* is a gas near the point of liquefaction, and does not show that regularity of behavior under changes of temperature and pressure characteristic of a gas when at a temperature much above the point of liquefaction. All gases treated in this chapter (except steam) are supposed in a condition far removed from this stage. The following will illustrate the properties of vapors. See Fig. 520.

Let a quantity of liquid, say water, be introduced into a closed space, previously vacuous, of considerably larger volume than the water, and furnished with a manometer and thermometer. Vapor of water immediately begins to form in the space above the liquid, and continues to do so until its pressure attains a definite value dependent on the temperature, and not on the ratio of the volume of the vessel and the original volume of water ; e.g., if the temperature is 70° Fahrenheit, the vapor ceases to form when the tension reaches a value of 0.36 lbs. per sq. inch. If heat be gradually applied to raise the temperature, more vapor will form (with ebullition ; i.e., from the body of the liquid, unless the heat is applied very slowly), but the tension *will not rise above a fixed value for each temperature* (independent of size of vessel) *so long as there is any liquid left*. Some of these corresponding values, for water, are as follows : For a

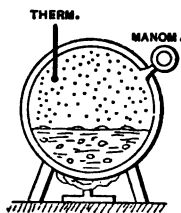

FIG. 520.

Fahr. temp.	= 70°	100°	150°	212°	220°	287°	300°
Tension (lbs. } per sq. in.) }	= 0.36	0.93	3.69	14.7	17.2	55.0	67.2

= one atm.

At any such stage the vapor is said to be *saturated*.

Finally, at some temperature, dependent on the ratio of the original volume of water to that of the vessel, all of the water will have been converted into vapor (i.e., steam); and if the temperature be still further increased, the tension also increases and *no longer depends on the temperature alone, but also on the heaviness of the vapor when the water disappeared*. The vapor is now said to be *superheated*, and conforms more in its properties to perfect gases.

470. Critical Temperature.—From certain experiments there seems to be reason to believe that at a certain temperature, called the *critical temperature*, different for different liquids, all of the liquid in the vessel (if any remains, and supposing the vessel strong enough to resist the pressure) is converted into vapor, whatever be the size of the vessel. That is, above the critical temperature the substance is necessarily gaseous, in the most exclusive sense, incapable of liquefaction by pressure alone; while below this temperature it is a vapor, and liquefaction will begin if, by compression in a cylinder and consequent increase of pressure, the tension can be raised to a value *corresponding, for a state of saturation, to the temperature* (in such a table as that just given for water). For example, if vapor of water at 220° Fahrenheit and tension of 10 lbs. per sq. inch (this is superheated steam, since 220° is higher than the temperature which for saturation corresponds to $p = 10$ lbs. per sq. inch) is compressed slowly (slowly, to avoid change of temperature) till the tension rises to 17.2 lbs. per sq. in., which (see above table) is the pressure of saturation for a temperature of 220° Fahrenheit for water-vapor, the vapor is saturated, i.e., liquefaction is ready to begin, and during any further slow reduction of volume the pressure remains constant and some of the vapor is liquefied.

By "perfect gases," or gases proper, we may understand, therefore, those which cannot be liquefied by pressure unaccompanied by great reduction of temperature; i.e., whose "critical temperatures" are very low. The critical temperature of N_2O , or nitrous oxide gas, is between -11° and $+8^\circ$ Centigrade, while that of oxygen is said to be at -118° Centi-

grade. [See p. 471, vol. 122 of the *Journal of the Franklin Institute*. For an account of the liquefaction of oxygen, etc., see the same periodical, January to June, 1878.]

471. Law of Charles (and of Gay Lussac).—The mode of graduation of the air-thermometer may be expressed in the following formula, which holds good (for practical purposes) within the ordinary limits of experiment for a given mass of *any perfect gas, the tension remaining constant*:

$$V = V_0 + 0.00367 V_0 t = V_0(1 + .00367t); \quad \dots (1)$$

in which V_0 denotes the volume occupied by the given mass at freezing-point under the given pressure, V its volume at any other temperature t Centigrade under the *same pressure*. Now, 273 being the reciprocal of .00367, we may write

$$V = V_0 \frac{(273 + t)}{273}; \quad \text{i.e., } \frac{V}{V_0} = \frac{T}{T_0} \cdot \cdot \left\{ \begin{array}{l} \text{press.} \\ \text{const.} \end{array} \right\}; \quad (2)$$

(see § 468;) in which T_0 = the *absolute temperature* of freezing-point, = 273° absolute Centigrade, and T the absolute temperature corresponding to t Centigrade. Eq. (2) is also true when T and T_0 are both expressed in Fahrenheit degrees (from absolute zero, of course). Accordingly, we may say that, *the pressure remaining the same, the volume of a given mass of gas varies directly as the absolute temperature*.

Since the weight of the given mass of gas is invariable at a given place on the earth's surface, we may

$$\text{always use the equation } V\gamma = V_0\gamma_0, \quad \dots \dots \dots (8)$$

pressure constant or not, and hence (2) may be rewritten

$$\frac{\gamma_0}{\gamma} = \frac{T}{T_0} \dots (\text{press. const.}); \quad \dots (4)$$

i.e., if the pressure is constant, the heaviness (and therefore the specific gravity) varies inversely as the absolute temperature.

Experiment also shows (§ 468) that if the volume [and therefore the heaviness, eq. (3)] remains constant, while the temperature varies, the tension p will change according to the following relation, in which p_0 = the tension when the temperature is freezing :

$$p = p_0 + \frac{1}{273} p_0 t = p_0 \frac{273 + t}{273}, \dots \quad (5)$$

t denoting the Centigrade temperature. Hence transforming, as before, we have

$$\frac{p}{p_0} = \frac{T}{T_0} \cdot \left\{ \begin{array}{l} \text{vol., and } \therefore \\ \text{heav., const.} \end{array} \right\}; \dots \quad (6)$$

or, *the volume and heaviness remaining constant, the tension of a given mass of gas varies directly as the absolute temperature.* This is called the *Law of Charles* (or of *Gay Lussac*).

472. General Formulæ for any Change of State of a Perfect Gas.

—If any two of the three quantities, viz., *volume* (or *heaviness*), *tension*, and *temperature*, are changed, the new value of the third is determinate from those of the other two, according

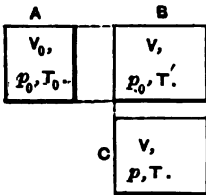

FIG. 521.

to a relation proved as follows (remembering that *henceforth the absolute temperature only* will be used, T , § 468): Fig. 521.

At *A* a certain mass of gas at a tension of p_0 , one atmosphere, and absolute temperature T_0 (freezing), occupies a volume V_0 . Let it now be heated to an absolute temp. = T' , without change of tension (expanding behind a piston, for instance). Its volume will increase to a value V which from (2) of § 471 will satisfy the relation

$$\frac{V}{V_0} = \frac{T'}{T_0} \dots \dots \dots (7)$$

(See *B* in figure.)

Let it now be heated without change of volume to an absolute temperature T (*C* in figure). Its volume is still V , but

the tension has risen to a value p , such that, on comparing B and C by eq. (6), we have

$$\frac{p}{p_0} = \frac{T}{T_0} \dots \dots \dots (8)$$

Combining (7) and (8), we obtain for *any state* in which the tension is p , volume V , and absolute temperature T , in

$$(General) \dots \dots \frac{pV}{T} = \frac{p_0V_0}{T_0}; \text{ or } \frac{pV}{T} = a \text{ constant}; \dots (9)$$

or

$$(General) \dots \dots \frac{p_m V_m}{T_m} = \frac{p_n V_n}{T_n}, \dots \dots \dots (10)$$

which, since

$$(General) \dots \dots V\gamma = V_0\gamma_0 = V_m\gamma_m = V_n\gamma_n, \dots \dots (11)$$

is true for any change of state, we may also write

$$(General) \dots \dots \frac{p}{\gamma T} = \frac{p_0}{\gamma_0 T_0}, \dots \dots \dots (12)$$

or

$$\frac{p_m}{\gamma_m T_m} = \frac{p_n}{\gamma_n T_n} \dots \dots \dots (13)$$

These equations (9) to (13), inclusive, hold good for any state of a mass of any perfect gas (most accurately for air). The subscript 0 refers to the state of one-atmosphere tension and freezing-point temperature, m and n to any two states whatever (within practical limits); γ is the heaviness, §§ 7 and 409, and T the *absolute temperature*, § 468.

If p , V , and T of equation (9) be treated as variables, and laid off to scale as co-ordinates parallel to three axes in space, respectively, the surface so formed of which (9) is the equation is a hyperbolic paraboloid.

473. Examples.—EXAMPLE 1.—What cubic space will be occupied by 2 lbs. of hydrogen gas at a tension of two atmospheres and a temperature of 27° Centigrade?

With the *inch-lb.-sec.* system we have $p_s = 14.7$ lbs. per sq. inch, $\gamma_s = [.0056 \div 1728]$ lbs. per cubic inch, and $T_s = 273^\circ$ absolute Centigrade, when the gas is at freezing-point at one atmosphere (i.e., in *state sub-zero*). In the state mentioned in the problem, we have $p = 2 \times 14.7$ lbs. per sq. in.,

$$T = 273 + 27 = 300^\circ \text{ absolute Centigrade,}$$

while γ is required. Hence, from eq. (12),

$$\frac{2 \times 14.7}{\gamma \cdot 300} = \frac{14.7}{(.0056 \div 1728)273};$$

$\therefore \gamma = \frac{.0102}{1728}$ lbs. per cub. in. = .0102 lbs. per cub. foot; and if the total weight, = G , = $V\gamma$, is to be 2 lbs., we have (ft., lb., sec.) $V = 2 \div .0102 = 196$ cubic feet.—*Ans.*

EXAMPLE 2.—A mass of air originally at 24° Centigrade and a tension indicated by a barometric column of 40 inches of mercury has been simultaneously reduced to half its former volume and heated to 100° Centigrade; required its tension in this new state, which we call the state n , m being the original state. Use the inch, lb., sec. We have given, therefore, $p_m = \frac{40}{30} \times 14.7$ lbs. per sq. inch, $T_m = 273 + 24 = 297^\circ$ absolute Centigrade, the ratio

$$V_m : V_n = 2 : 1, \text{ and } T_n = 273 + 100 = 373^\circ \text{ Abs. Cent.};$$

while p_n is the unknown quantity. From eq. (10), hence,

$$p_n = \frac{V_m}{V_n} \cdot \frac{T_n}{T_m} \cdot p_m = 2 \times \frac{373}{297} \cdot \frac{40}{30} \times 14.7 = 49.22 \text{ lbs. per sq. in.},$$

which an ordinary steam-gauge would indicate as

$$(49.22 - 14.7) = 34.52 \text{ lbs. per sq. inch.}$$

(That is, if the weather barometer indicated exactly 14.7 lbs per sq. inch.)

EXAMPLE 3.—A mass of air, Fig. 522, occupies a rigid closed vessel at a temperature of 15° Centigrade (equal to that of surrounding objects) and a tension of four atmospheres [*state m*].

By opening a stop-cock a few seconds, thus allowing a portion of the gas to escape quickly, and then shutting it, the remainder

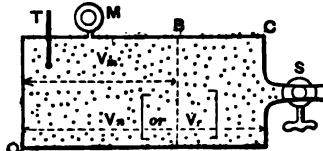

FIG. 522.

of the air [now in *state n*] is found to have a tension of only 2.5 atmospheres (measured immediately); its temperature cannot be measured immediately (so much time being necessary to affect a thermometer), and is less than before. To compute this temperature, T_n , we allow the air now in the vessel to come again to the same temperature as surrounding objects (15° Centigrade); find then the tension to be 2.92 atmospheres. Call the last state, *state r* (inch, lb., sec.). The problem then stands thus:

$$\begin{array}{l}
 p_m = 4 \times 14.7 \\
 \gamma_m = ? \\
 T_m = 288^\circ \text{ Abs. Cent.}
 \end{array}
 \left|
 \begin{array}{l}
 p_n = 2.5 \times 14.7 \\
 \gamma_n = ? \\
 T_n = ? \left\{ \begin{array}{l} \text{principal} \\ \text{unknown} \end{array} \right.
 \end{array}
 \right.
 \begin{array}{l}
 p_r = 2.92 \times 14.7 \\
 \gamma_r = \gamma_n \text{ (since } V_r = V_n) \\
 T_r = T_m = 288^\circ \text{ Abs. Cent.}
 \end{array}$$

In states *n* and *r* the heaviness is the same; hence an equation like (6) of § 471 is applicable, whence

$$\frac{p_n}{p_r} = \frac{T_n}{T_r}, \text{ or } T_n = \frac{2.5 \times 14.7}{2.92 \times 14.7} \times 288 = 246^\circ \text{ Abs. Cent.}$$

or — 27° Centigrade; considerably *below freezing*, as a result of allowing the sudden escape of a portion of the air, and the consequent sudden expansion, and reduction of tension, of the remainder. In this sudden passage from state *m* to state *n*, the remainder altered its heaviness (and its volume in inverse ratio) in the ratio (see eqs. (11) and (10) of § 472)

$$\frac{\gamma_n}{\gamma_m} = \frac{V_m}{V_n} = \frac{p_n}{p_m} \cdot \frac{T_m}{T_n} = \frac{2.5 \times 14.7}{4 \times 14.7} \cdot \frac{288}{246} = 0.73.$$

Now the heaviness in state *m* (see eq. (12), § 472) was

$$\gamma_m = \frac{p_m}{T_m} \cdot \frac{\gamma_o T_o}{p_o} = \frac{4 \times 14.7}{288} \cdot \frac{.0807 \cdot 273}{1728 \cdot 14.7} = \frac{.306}{1728}$$

lbs. per cub. in. = .306 lbs. per cub. ft.

$$\therefore \gamma_n = 0.73 \times \gamma_m = 0.223 \text{ lbs. per cub. ft.,}$$

and also, since $V_m = 0.73 V_n$, about $\frac{27}{100}$ of the original quantity of air in vessel has escaped.

[NOTE.—By numerous experiments like this, the law of cooling, when a mass of gas is allowed to expand suddenly (as, e.g., behind a piston, doing work) has been determined; and *vice versa*, the law of heating under sudden compression; see § 487.]

474. The Closed Air-manometer.—If a manometer be formed of a straight tube of glass, of uniform cylindrical bore, which is partially filled with mercury and then inverted in a cistern of mercury, a quantity of air having been left between the mercury and the upper end of the tube, which is closed, the tension of this confined air (to be computed from its observed volume and temperature) must be added to that due to the mercury column, in order to obtain the tension p' to be measured. See Fig. 523. The advantage of this kind of instrument is, that to measure great tensions the tube need not be very long. Let the temperature

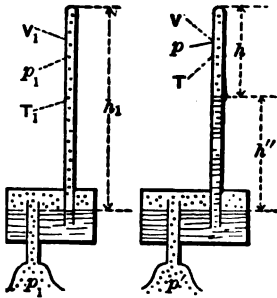

FIG. 523.

T_1 of whole instrument, and the tension p_1 of the air or gas in the cistern, be known when the mercury in the tube stands at the same level as that in the cistern. The tension of the air in the tube must now be p , also, its temperature T_1 , and its volume is $V_1 = Fh_1$, F being the sectional area of the bore of the tube; see on left of figure. When the instrument is used, gas of unknown tension p' is admitted to the cistern, the temperature of the whole instrument being noted ($= T$), and the heights h and h'' are observed ($h + h''$ cannot be put $= h$,

unless the cistern is very large). p' is then computed as follows (eq. (2), § 413):

$$p' = h'' \gamma_m + p; \dots \dots \dots (1)$$

in which p = the tension of the air in the tube, and γ_m the heaviness of mercury. But from eq. (10), § 472, putting $V_1 = Fh_1$, and $V = Fh$,

$$p = p_1 \frac{V_1}{V} \cdot \frac{T}{T_1} = \frac{h_1}{h} \frac{T}{T_1} p_1 \dots \dots \dots (2)$$

Hence finally, from (1) and (2),

$$p' = h'' \gamma_m + \frac{h_1}{h} \cdot \frac{T}{T_1} p_1 \dots \dots \dots (3)$$

Since T_1 , p_1 , and h_1 are fixed constants for each instrument, we may, from (3), compute p' for any observed values of h and T (N.B. T and T_1 are *absolute temperatures*), and construct a series of tables each of which shall give values of p' for a range of values of h , and one special value of T .

EXAMPLE.—Supposing the fixed constants of a closed air-manometer to be (in inch-lb.-sec. system) $p_1 = 14.7$ (or one atmosphere), $T_1 = 285^\circ$ Abs. Cent. (i.e., 12° Centigrade), and $h_1 = 3' 4'' = 40$ inches; required the tension in the cistern indicated by $h'' = 25$ inches and $h = 15$ inches, when the temperature is -3° Centigrade, or $T = 270^\circ$ Abs. Cent.

For mercury, $\gamma_m = [848.7 \div 1728]$ (§ 409) (though strictly it should be specially computed for the temperature, since it varies about .00002 of itself for each Centigrade degree). Hence, eq. (3),

$$p' = \frac{25 \times 848.7}{1728} + \frac{40}{15} \cdot \frac{270}{285} \times 14.7 = 12.26 + 37.13 = 49.39$$

lbs. per sq. inch, or nearly $3\frac{1}{2}$ atmospheres [steam-gauge would read 34.7 lbs. per sq. in.].

475. Mariotte's Law, (or Boyle's,) Temperature Constant; i.e., Isothermal Change.—If a mass of gas be compressed, or al-

lowed to expand, *isothermally*, i.e., without change of temperature (practically this cannot be done unless the walls of the vessel are conductors of heat, and then the motion must be slow), eq. (10) of § 472 now becomes (since $T_m = T_n$)

$$\left\{ \begin{array}{l} \text{Mariotte's Law,} \\ \text{Temp. constant} \end{array} \right\} . V_m p_m = V_n p_n, \text{ or } \frac{p_m}{p_n} = \frac{V_n}{V_m}; \quad (1)$$

i.e., *the temperature remaining unchanged, the tensions are inversely proportional to the volumes, of a given mass of a perfect gas; or, the product of volume by tension is a constant quantity.* Again, since $V_m \gamma_m = V_n \gamma_n$ for any change of state,

$$\left\{ \begin{array}{l} \text{Mariotte's Law,} \\ \text{Temp. constant} \end{array} \right\} . . \frac{p_m}{p_n} = \frac{\gamma_m}{\gamma_n}, \text{ or } \frac{p_m}{\gamma_m} = \frac{p_n}{\gamma_n}; \quad (2)$$

i.e., *the pressures (or tensions) are directly proportional to the (first power of the) heavinesses, if the temperature is the same.*

This law, which is very closely followed by all the perfect gases, was discovered by Boyle in England and Mariotte in France more than two hundred years ago, but of course is only a particular case of the general formula, for any change of state, in § 472. It may be verified experimentally in several ways. E.g., in Fig. 524, the tube OM being closed at the top, while PN is open, let mercury be poured in at P until it reaches the level $A'B'$. The air in OA' is now at a tension of one atmosphere. Let more mercury be slowly poured in at P , until the air confined in O has been compressed to a volume $OA'' = \frac{1}{2}$ of OA' , and the height $B''E''$ then measured; it will be found to be 30 inches; i.e., the tension of the air in O is now *two atmospheres* (corresponding to 60 inches of mercury).

Again, compress the air in O to $\frac{1}{3}$ its original volume (when at one atmosphere), i.e., to volume $OA''' = \frac{1}{3}OA'$, and the mercury height $B'''E'''$ will be 60 inches, showing a tension of three atmospheres in the confined air at O (90

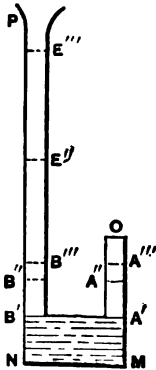

FIG. 524.

inches of mercury in a barometer). It is understood that the temperature is the same, i.e., that time is given the compressed air to acquire the temperature of surrounding objects after being heated by the compression, if sudden.

[NOTE.—The law of decrease of steam-pressure in a steam-engine cylinder, after the piston has passed the point of “cut-off” and the confined steam is expanding, does not materially differ from Mariotte’s law, which is often applied to the case of expanding steam; see § 479.]

While Mariotte’s law may be considered exact for practical purposes, it is only approximately true, the amount of the deviations being different at different temperatures. Thus, for decreasing temperatures the product Vp of volume by tension becomes smaller, with most gases.

EXAMPLE 1.—If a mass of compressed air expands in a cylinder behind a piston, having a tension of 60 lbs. per sq. inch (45.3 by steam-gauge) at the beginning of the expansion, which is supposed slow (that the temperature may not fall); then when it has doubled in volume its tension will be only 30 lbs. per sq. inch; when it has tripled in volume its tension will be only 20 lbs. per sq. inch, and so on.

EXAMPLE 2. *Diving-bell.*—Fig. 525. If the cylindrical diving bell AB is 10 ft. in height, in what depth, $h = ?$, of salt water, can it be let down to the bottom, without allowing the water to rise in the bell more than a distance $a = 4$ ft.? Call the horizontal sectional area, F . The mass of air in the bell is constant, at a constant temperature. *First, algebraically;* at the surface this mass of air occupied a volume $V_m = Fh''$ at a tension $p_m = 14.7 \times 144$ lbs. per sq. ft., while at the depth mentioned it is compressed to a volume $V_n = F(h'' - a)$, and is at a tension $p_n = p_m + (h - a)\gamma_w$, in which $\gamma_w =$ heaviness of salt water. Hence, from eq. (1),

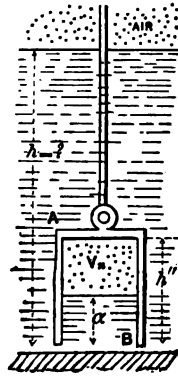

FIG. 525.

$$p_m Fh'' = [p_m + (h - a)\gamma_w]F(h'' - a); \dots (3)$$

$$\therefore h = a \left[1 + \frac{p_m}{(h'' - a)\gamma_w} \right]; \dots \dots \dots (4)$$

hence, *numerically*, (ft., lb., sec.)

$$h = 4 \times \left[1 + \frac{14.7 \times 144}{(10 - 4) \times 64} \right] = 26.05 \text{ feet.}$$

476. Mixture of Gases.—It is sometimes stated that if a vessel is occupied by a mixture of gases (between which there is no chemical action), the tension of the mixture is equal to the sum of the pressures of each of the component gases present; or, more definitely, is equal to the sum of the pressures which the separate masses of gas would exert on the vessel if each in turn occupied it alone at the same temperature.

This is a direct consequence of Mariotte's law, and may be demonstrated as follows:

Let the actual tension be p , and the capacity of the vessel V . Also let V_1, V_2 , etc., be the volumes actually occupied by the separate masses of gas, so that

$$V_1 + V_2 + \dots = V; \dots \dots \dots (1)$$

and p_1, p_2 , etc., the pressures they would individually exert when occupying the volume V alone at the same temperature. Then, by Mariotte's law,

$$Vp_1 = V_1p; \quad Vp_2 = V_2p; \quad \text{etc.}; \dots \dots (2)$$

whence, by addition, we have

$$V(p_1 + p_2 + \dots) = (V_1 + V_2 + \dots)p;$$

i.e., $p = p_1 + p_2 + \dots \dots \dots (3)$

Of course, the same statement applies to any number of separate parts into which we may imagine a mass of homogeneous gas to be divided.

For numerical examples and practical questions in the solution of which this principle is useful, see p. 239, etc., Rankine's Steam-engine. (Rankine uses 0.365, where 0.367 has been used here.)

477. **Barometric Levelling.**—By measuring with a barometer the tension of the atmosphere at two different levels, simultaneously, and on a still day, the two localities not being widely separated horizontally, we may compute their vertical distance apart if the temperature of the stratum of air between them is known, being the same, or nearly so, at both stations. Since the heaviness of the air is different in different layers of the vertical column between the two elevations N and M , Fig. 526, we cannot immediately regard the whole of such a column as a free body (as was done with a liquid, § 412), but must consider a horizontal thin lamina, L , of thickness $= dz$ and at a distance $= z$ (variable) below M , the level of the upper station, N being the lower level at a distance, h , from M .

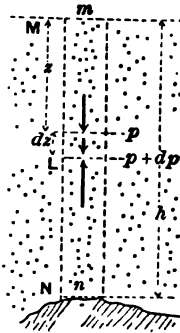

FIG. 526.

The tension, p , must increase from M downwards, since the lower laminae have to support a greater weight than the upper; and the heaviness γ must also increase, proportionally to p , since we assume that all parts of the column are at the same temperature, thus being able to apply Mariotte's law. Let the tension and heaviness of the air at the upper base of the elementary lamina, L , be p and γ respectively. At the lower base, a distance dz below the upper, the tension is $p + dp$. Let the area of the base of lamina be F ; then the vertical forces acting on the lamina are Fp , downward; its weight γFdz downward; and $F(p + dp)$ upward. For its equilibrium $\Sigma(\text{vert. comps.})$ must $= 0$;

$$\therefore F(p + dp) - Fp - F\gamma dz = 0;$$

$$\text{i.e., } dp = \gamma dz, \quad \dots \dots \dots (1)$$

which contains three variables. But from Mariotte's law, § 475, eq. (2), if p_n and γ_n refer to the air at N , we may substitute $\gamma = \frac{\gamma_n}{p_n} p$ and obtain, after dividing by p , to separate the variables p and z ,

$$\frac{p_n}{\gamma_n} \cdot \frac{dp}{p} = dz. \quad \dots \dots \dots (2)$$

Summing equations like (2), one for each lamina between M (where $p = p_m$ and $z = 0$) and N (where $p = p_n$ and $z = h$), we have

$$\frac{p_n}{\gamma_n} \cdot \int_{p_m}^{p_n} \frac{dp}{p} = \int_0^h dz;$$

$$\text{i.e., } h = \frac{p_n}{\gamma_n} \log_e \left[\frac{p_n}{p_m} \right], \quad \dots \dots \dots (3)$$

which gives h , the difference of level, or altitude, between M and N , in terms of the observed tensions p_n and p_m , and of γ_n , the heaviness of the air at N , which may be computed from eq. (12), § 472, substituting from which we have finally

$$h = \frac{p_0}{\gamma_0} \cdot \frac{T_n}{T_0} \cdot \log_e \left[\frac{p_n}{p_m} \right], \quad \dots \dots \dots (4)$$

in which the subscript 0 refers to freezing-point and one atmosphere tension; T_n and T_0 are absolute temperatures. For the ratio $p_n : p_m$ we may put the equal ratio $h_n : h_m$ of the actual barometric heights which measure the tensions. The \log_e (or Napierian, or natural, or hyperbolic, \log_e) = (common \log_e to base 10) $\times 2.30258$. From § 394, γ_0 of air = 0.08076 lbs. per cub. ft., and $p_0 = 14.701$ lbs. per sq. inch; $T_0 = 273^\circ$ Abs. Cent.

If the temperature of the two stations (both in the *shade*) are not equal, a mean temp. = $\frac{1}{2}(T_m + T_n)$ may be used for T_n in eq. (4), for approximate results. Eq. (4) may then be written

$$h \text{ (in feet)} = 26213 \frac{T_n}{T_0} \cdot \log_e \left[\frac{p_n}{p_m} \right]. \quad \dots \dots \dots (5)$$

The quantity $\frac{p_0}{\gamma_0} = 26213$ ft., just substituted, is called the *height of the homogeneous atmosphere*, i.e., the ideal height which the atmosphere would have, if incompressible and non-

expansive like a liquid, in order to exert a pressure of 14.701 lbs. per sq. inch upon its base, being throughout of a constant heaviness = .08076 lbs. per cub. foot.

By inversion of eq. (4) we may also write

$$p_m e^{\frac{\gamma_0}{p_0} \cdot \frac{T_0}{T_n} \cdot h} = p_n, \quad \dots \dots (6)$$

where $e = 2.71828$ = the Napierian Base, which is to be raised to the power whose index is the abstract number $\frac{\gamma_0}{p_0} \cdot \frac{T_0}{T_n} \cdot h$, and the result multiplied by p_m to obtain p_n .

EXAMPLE.—Having observed as follows (simultaneously):

At lower station N , $h_n = 30.05$ in. mercury; temp. = 77.6° F.;
 “ upper “ M , $h_m = 23.66$ “ “ “ = 70.4° F.;

required the altitude h . From these figures we have a mean absolute temperature of $460^\circ + \frac{1}{2}(77.6 + 70.4) = 534^\circ$ Abs. Fahr.; hence, from (5),

$$h = 26213 \times \frac{114}{113} \times 2.30258 \times \log_{10} \left[\frac{30.05}{23.66} \right] = 6787.9 \text{ ft.}$$

(Mt. Guanaxuato, in Mexico, by Baron von Humboldt.) Strictly, we should take into account the latitude of the place, since γ_0 varies with g (see § 76), and also the decrease in the intensity of gravitation as we proceed farther from the earth's centre, for the mercury in the barometer weighs less per cubic inch at the upper station than at the lower.

Tables for use in barometric levelling can be found in Trautwine's Pocket-book, and in Searles's Field-book for Railroad Engineers, as also tables of boiling-points of water under different atmospheric pressures, forming the basis of another method of determining heights.

478. **Adiabatic Change—Poisson's Law.**—By an *adiabatic* change of state, on the part of a gas, is meant a compression or expansion in which work is done upon the gas (in compress-

ing it) or *by the gas* (in expanding against a resistance) when there is *no transmission of heat* between the gas and enclosing vessel, or surrounding objects, by conduction or radiation. This occurs when the volume changes in a vessel of non-conducting material, or when the compression or expansion takes place *so quickly* that there is no time for transmission of heat to or from the gas.

The experimental facts are, that if a mass of gas in a cylinder be suddenly compressed to a smaller volume its temperature is raised, and its tension increased more than the change of volume would call for by Mariotte's law; and *vice versa*, if a gas at high tension is allowed to expand in a cylinder and drive a piston against a resistance, its temperature falls, and its tension diminishes more rapidly than by Mariotte's law.

Again (see Example 3, § 473), if $\frac{2}{100}$ of the gas in a rigid vessel, originally at 4 atmos. tension and temperature of 15° Cent., is allowed to escape suddenly through a stop-cock into the outer air, the remainder, while increasing its volume in the ratio 100 : 73, is found to have cooled to - 27° Cent., and its tension to have fallen to 2.5 atmospheres; whereas, by Mariotte's law, if the temperature had been kept at 288° Abs. Cent., the tension would have been lowered to $\frac{73}{100}$ of 4, i.e., to 2.92 atmospheres only.

The reason for this cooling during sudden expansion is, according to the *Kinetic Theory of Gases*, that since the "sensible heat" (i.e., that perceived by the thermometer), or "*hotness*" of a gas depends on the velocity of its incessantly moving molecules, and that each molecule after impact with a *receding* piston has a less velocity than before, the temperature necessarily falls; and *vice versa*, when an advancing piston compresses the gas into a smaller volume.

If, however, a mass of gas expands *without doing work*, as when, in a vessel of two chambers, one a vacuum, the other full of gas, communication is opened between them, and the gas allowed to fill both chambers, *no cooling* is noted in the mass as a whole (though parts may have been cooled temporarily).

By experiments similar to that in Example 3, § 473, it has

been found that for air and the "perfect gases," in an adiabatic change of volume [and therefore of heaviness], the tension varies inversely with the 1.41th power of the volume. This is called *Poisson's Law*. For ordinary purposes (as Weisbach suggests) we may use $\frac{4}{3}$ instead of 1.41, and hence write

$$\left. \begin{array}{l} \text{Adiabat.} \\ \text{Change} \end{array} \right\} \cdot \cdot \frac{p_m}{p_n} = \left(\frac{V_m}{V_n} \right)^{\frac{4}{3}}, \cdot \cdot \text{ or } \frac{p_m}{p_n} = \left(\frac{V_n}{V_m} \right)^{\frac{4}{3}}; \cdot \cdot \cdot (1)$$

and combining this relation with the general eqs. (10) and (13), § 472, we have also

$$\left. \begin{array}{l} \text{Adiabat.} \\ \text{Change} \end{array} \right\} \cdot \cdot \cdot \cdot \cdot \frac{p_m}{p_n} = \left(\frac{T_m}{T_n} \right)^3, \cdot \cdot \cdot \cdot \cdot \cdot (2)$$

i.e., the tension varies directly as the cube of the absolute temperature; also,

$$\left. \begin{array}{l} \text{Adiabat.} \\ \text{Change} \end{array} \right\} \cdot \left(\frac{V_m}{V_n} \right) = \left(\frac{T_n}{T_m} \right)^3; \text{ or } \frac{V_n}{V_m} = \left(\frac{T_n}{T_m} \right)^3; \cdot \cdot \cdot (3)$$

i.e., the volume is inversely, and the heaviness directly, as the square of the absolute temperature.

Here *m* and *n* refer to any two adiabatically related states. *T* is the *absolute temperature*.

EXAMPLE 1.—Air in a cylinder at 20° Cent. is *suddenly* compressed to $\frac{1}{6}$ its original volume (and therefore is six times as dense, i.e., has six times the heaviness, as before). To what temperature is it heated? Let *m* be the initial state, and *n* the final. From eq. (3) we have

$$\frac{T_n}{293} = \sqrt[3]{\frac{6}{1}}; \therefore T_n = 718^\circ \text{ Abs. Cent.},$$

or nearly double the absolute temperature of boiling water.

EXAMPLE 2.—After the air in Example 1 has been given time to cool again to 20° Cent. (temperature of surrounding objects) it is allowed to resume, suddenly, its first volume, i.e.,

to increase its volume sixfold by expanding behind a piston. To what temperature has it cooled? Here $T_m = 293^\circ$ Abs. Cent., the ratio $V_m : V_n = \frac{1}{6}$, and T_n is required. Hence, from (3),

$$\frac{T_n}{293} = \sqrt{\frac{1}{6}}; \therefore T_n = 293 \div \sqrt{6} = 119.5^\circ \text{ Abs. Cent.},$$

or $= -154^\circ$ Cent., indicating extreme cold.

From these two examples the principle of one kind of ice-making apparatus is very evident. As to the work necessary to compress the air in Example 1, see § 483. It is also evident why motors using compressed air expansively have to encounter the difficulty of frozen watery vapor (present in the air to some extent).

EXAMPLE 3.—What is the tension of the air in Example 1 (suddenly compressed to $\frac{1}{6}$ its original volume) immediately after the compression, if the original tension was one atmosphere? That is, with $V_n : V_m = 1 : 6$, and $p_m = 14.7$ lbs. per sq. inch, $p_n = ?$ From eq. (1), (in., lb., sec.,)

$$p_n = 14.7 \times 6^2 = 14.7 \sqrt{216} = 216$$

lbs. per sq. inch; whereas, if, after compression and without change of volume, it cools again to 20° Cent., the tension is only $14.7 \times 6 = 88.2$ lbs. per sq. inch (now using Mariotte's law).

479. Work of Expanding Steam following Mariotte's Law.—Although gases do not in general follow Mariotte's law in expanding behind a piston (without special provision for supplying heat), it is found that the tension of saturated steam (i.e., saturated at the beginning of the expansion) in a steam engine cylinder, when left to expand after the piston has passed the point of "cut-off," diminishes very nearly in accordance with Mariotte's law, which may therefore be applied in this case to find the work done per stroke, and thence the power. In Fig. 527 a horizontal steam-cylinder is

shown in which the piston is making its left-to-right stroke.

The "back-pressure" is constant and $= Fq$, F being the area of the piston and q the intensity (i.e., per unit area) of the back or exhaust pressure on the right side of the piston; while the forward pressure on the left face of the piston $= Fp$, in which p is the steam-pressure per unit area, and is different at different points of the stroke. While the piston is passing from O'' to D'' , p is constant, being $= p_b =$ the boiler-pressure, since the steam-port is still open. Between D'' and C'' , however, the steam being cut off (i.e., the steam-port is closed) at D'' , a distance a from O'' , p decreases with Mariotte's law (nearly), and its value is $(Fa \div Fx)p_b$ at any point on $C''D''$, x being the distance of the point from O'' .

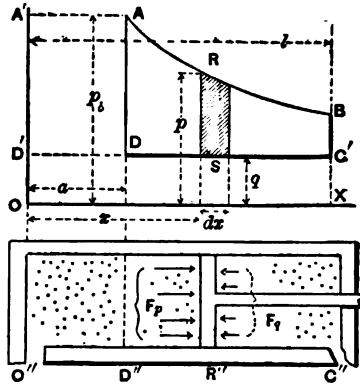

FIG. 527.

Above the cylinder, conceive to be drawn a diagram in which an axis OX is \parallel to the cylinder-axis, OY an axis \perp to the same, while O is vertically above the left-hand end of the cylinder. As the piston moves, let the value of p corresponding to each of its positions be laid off, to scale, in the vertical immediately above the piston, as an ordinate from the axis X . Make $OD' = q$ by the same scale, and draw the horizontal $D'C'$. Then the effective work done on the piston-rod while it moves through any small distance dx is

$$dW = \text{force} \times \text{distance} = F(p - q)dx,$$

and is proportional to the area of the strip RS , whose width is dx and length $= p - q$; so that the effective work of one stroke is

$$\int_{O''}^{O'} dW = F \int_{x=0}^{x=1} (p - q) dx, \quad \dots (1)$$

and is represented graphically by the area $A'ARB C'D'A'$. From O'' to D'' p is constant and $= p_b$ (while q is constant at all points), and x varies from 0 to a ;

$$\therefore \left[\frac{D''}{O''} W = F(p_b - q) \int_0^a dx = F(p_b - q)a, \quad \dots (2) \right.$$

which may be called the *work of entrance*, and is represented by the area of the rectangle $A'ADD'$.

From D'' to C'' p is variable and, by Mariotte's law, $= \frac{a}{x} p_b$;

$$\therefore \left[\frac{C''}{D''} W = F \int_a^l (p - q) dx = F \left[a p_b \int_a^l \frac{dx}{x} - q \int_a^l dx \right]; \right.$$

i.e.,

$$\left[\frac{C''}{D''} W = F \left[a p_b \log_e \left(\frac{l}{a} \right) - q(l - a) \right] \quad \dots (3) \right.$$

= the *work of expansion*, adding which to that of entrance, we have for the *total effective work of one stroke*

$$W = F p_b a \left[1 + \log_e \left(\frac{l}{a} \right) \right] - F q l. \quad \dots (4)$$

By effective work we mean that done upon the piston-rod and thus transmitted to outside machinery. Suppose the engine to be "double-acting"; then at the end of the stroke a communication is made, by motion of the proper valves, between the space on the left of the piston and the condenser of the engine; and also between the right of the piston and the boiler (that to the condenser now being closed). On the return stroke, therefore, the conditions are the same as in the forward stroke, except that the two sides of the piston have changed places as regards the pressures acting on them, and thus the same amount of effective work is done as before.

If n revolutions of the fly-wheel are made per unit of time (two strokes to each revolution), the effective work done per unit of time, i.e., the *power* of the engine, is

$$L = 2n W = 2n F \left[a p_b \left[1 + \log_e \left(\frac{l}{a} \right) \right] - q l \right]. \quad (5)$$

For simplicity the above theory has omitted the consideration of "clearance," that is, the fact that at the point of "cut-off" the mass of steam which is to expand occupies not only the cylindrical volume Fa , but also the "clearance" or small space in the steam-passages between the valve and the entrance of the cylinder, the space between piston and valve which is never encroached upon by the piston. "Wire-drawing" has also been disregarded, i.e., the fact that during communication with the boiler the steam-pressure on the piston is a little less than boiler-pressure. For these the student should consult special works, and also for the consideration of water mixed with the steam, etc. Again, a strict analysis should take into account the difference in the areas which receive fluid-pressure on the two sides of the piston.

EXAMPLE 1.—A reciprocating steam-engine makes 120 revolutions per minute, the boiler-pressure is 40 lbs. by the gauge (i.e., $p_b = 40 + 14.7 = 54.7$ lbs. per sq. inch), the piston area is $F = 120$ sq. in., the length of stroke $l = 16$ in., the steam being "cut off" at $\frac{1}{4}$ stroke ($\therefore a = 4$ in., and $l : a = 4.00$), and the exhaust pressure corresponds to a "vacuum of 25 inches" (by which is meant that the pressure of the exhaust steam will balance 5 inches of mercury), whence $q = \frac{5}{30}$ of $14.7 = 2.45$ lbs. per sq. inch. Required the work per stroke, W , and the corresponding power L .

Since $l : a = 4$, we have $\log_e 4 = 2.302 \times .60206 = 1.386$, and from eq. (4), (foot, lb., sec.),

$$W = \frac{120}{144} (54.7 \times 144) \cdot \frac{1}{4} \cdot [2.386] - \frac{120}{144} (2.45 \times 144) \cdot \frac{1}{4}$$

$$= 5165.86 - 392.0 = 4773.868 \text{ ft. lbs. of work per stroke,}$$

and therefore the power at 2 rev. per sec. (eq. 5) is

$$L = 2 \times 2 \times 4773.87 = 19095.5 \text{ ft. lbs. per second.}$$

Hence in horse-powers, which, in ft.,-lb.-sec. system, $= L \div 550$,

$$\text{Power} = 19095.5 \div 550 = 34.7 \text{ H. P.}$$

EXAMPLE 2.—Required the weight of steam consumed per

second by the above engine with given data; assuming with Weisbach that the heaviness of saturated steam at a definite pressure (and a *corresponding temperature*, § 469) is about $\frac{1}{3}$ of that of air at the same pressure and temperature.

The heaviness of air at 54.7 lbs. per sq. in. tension and temperature 287° Fahr. (see table, § 469) would be, from eq. (12) of § 472 (see also § 409),

$$\gamma = \frac{\gamma_0 T_0}{T} \cdot \frac{p}{p_0} = \frac{.0807 \times 492}{460 + 287} \cdot \frac{54.7}{14.7} = 0.198$$

lbs. per cub. foot, $\frac{1}{3}$ of which is 0.1237 lbs. per cub. ft. Now the volume* of steam, of this heaviness, admitted from the boiler at each stroke is $V = Fa = \frac{1}{144} \cdot \frac{1}{3} = 0.2777$ cub. ft., and therefore the weight of steam used per second is

$$4 \times .2777 \times 0.1237 = 0.1374 \text{ lbs.}$$

Hence, per hour, $0.1374 \times 3600 = 494.6$ lbs. of feed-water are needed for the boiler.

If, with this same engine, the steam is used at full boiler pressure throughout the whole stroke, the power will be greater, viz. $= 2nFV(p_0 - q) = 33440$ ft. lbs. per sec., but the consumption* of steam will be four times as great; and hence in economy of operation it will be only 0.44 as efficient (nearly).

480. Graphic Representation of any Change of State of a Confined Mass of Gas.—The curve of expansion AB in Fig. 527 is an equilateral hyperbola, the axes X and Y being its asymptotes. If compressed air were used instead of steam its expansion curve would also be an equilateral hyperbola if its temperature could be kept from falling during the expansion (by injecting hot-water spray, e.g.), and then, following Mariotte's law, we would have, as for steam, (§ 475,) $pV = \text{constant}$, i.e., $pFx = \text{constant}$, and therefore $px = \text{constant}$, which is the equation of a hyperbola, p being the ordinate and x the abscissa. This curve (dealing with a perfect gas) is also called an *isothermal*, the x and y co-ordinates of its points being pro-

* We here neglect the practical fact that a portion of the fresh steam entering the cylinder is condensed prematurely, so that the actual consumption is somewhat greater than as here derived.

portional to the volume and tension, respectively, of a mass of air (or perfect gas) whose temperature is maintained constant.

Hence, *in general*, if a mass of gas be confined in a rigid cylinder of cross-section F (area), provided with an air-tight piston, Fig. 528, its volume, Fx , is proportional to the distance $OD = x$ (of the piston from the closed end of the cylinder) taken as an abscissa, while its tension p at the same instant may be laid off as an ordinate from D .

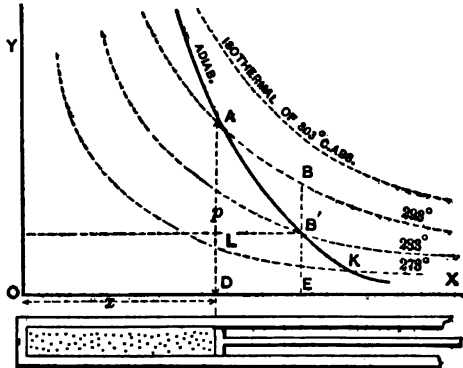

FIG 528.

Thus a point A is fixed. Describe an equilateral hyperbola through A , asymptotic to X and Y , and mark it with the observed temperature (absolute) of the air at this instant. In a similar way the diagram can be filled up with a great number of equilateral hyperbolas, or *isothermal curves*, each for its own temperature. Any point whatever (i.e., above the critical temperature) in the plane angular space YOX will indicate by its co-ordinates a volume and a tension, while the corresponding absolute temperature T will be shown by the hyperbola passing through the point, since these three variables always satisfy the relation (§ 472)

$$\frac{pV}{T} = \text{const.}; \text{ i.e., } \frac{pF\omega}{T} = \frac{p_0V_0}{T_0} \dots (1)$$

Any change of state of the gas in the cylinder may now be represented by a line in the diagram connecting the two points corresponding to its initial and final states. Thus, a point moving along the line AB , a portion of the isothermal marked 293° Abs. Cent., represents a motion of the piston from D to E , and a consequent increase of volume, accompanied by just sufficient absorption of heat by the gas (from other bodies) to maintain its temperature at that figure (viz., its temperature at

A). If the piston move from D to E , *without transmission of heat*, i.e., *adiabatically* (§ 478), the tension falls more rapidly, and a point moving along the line AB' represents the corresponding continuous change of state. AB' is a portion of an *adiabatic curve*, whose equation, from § 478, is

$$\frac{p}{p_K} = \left[\frac{F x_K}{F x} \right]^{\frac{1}{\gamma}}, \quad \text{or} \quad p x^{\frac{1}{\gamma}} = p_K x_K^{\frac{1}{\gamma}} = \text{const.}; \quad (1)$$

in which p_K and x_K refer to the point K where this particular adiabatic curve cuts the isothermal of freezing-point. Evidently an adiabatic may be passed through any point of the diagram. The mass of gas in the cylinder may change its state from A to B' by an infinite number of routes, or lines on the diagram, the adiabatic route, however, being that most likely to occur for a rapid motion of the piston. For example, we may cool it without allowing the piston to move (and hence without altering its volume nor the abscissa x) until the pressure falls to a value $p_{B'} = DL = EB'$, and this change is represented by the vertical path from A to L ; and then allow it to expand, and push the piston from D to E (i.e., do external work), during which expansion heat is to be supplied at just such a rate as to keep the tension constant, $= p_{B'} = p_L$, this latter change corresponding to the horizontal path LB' from L to B' .

It is further noticeable that the *work done* by the expanding gas upon the *near face* of the piston (or done *upon* the gas when compressed) when the space dx is described by the piston, is $= Fpdx$, and therefore is proportional to the area pdx of the small vertical strip lying between the axis X and the line or route showing the change of state; whence the total work done on the near piston-face, being $= \int Fpdx$, is represented by the area $\int pdx$ of the plane figure between the initial and final ordinates, the axis X and the particular *route* followed between the initial and final states (N.B. We take no account here of the pressure on the other side of the piston, the latter depending on the style of engine). For example, the work done on the near face of the piston during adiabatic expansion

from D to E is represented by the plane figure $AB'EDA$, and is measured by its area.

The mathematical relations between the quantities of heat imparted or rejected by conduction and radiation, and transformed into work, in the various changes of which the confined gas is capable, belong to the subject of *Thermodynamics*, which cannot be entered upon here.

It is now evident how the cycle of changes which a definite mass of air or gas experiences when used in a hot-air engine, compressed-air engine, or air-compressor, is rendered more intelligible by the aid of such a diagram as Fig. 528; but it must be remembered that during the entrance into, or exit from, the cylinder, of the mass of gas used in one stroke, the distance x does not represent its volume, and hence the locus of the points in the diagram determined by the co-ordinates p and x during entrance and exit does not indicate changes of state in the way just explained for the mass when confined in the cylinder. However, the *work done* by or upon the gas during entrance and exit will still be represented by the plane figure included by that locus (usually a straight horizontal line, pressure constant) and the axis of X and the terminal ordinates.

481. Adiabatic Expansion in an Engine using Compressed Air.
 —Fig. 529. Let the compressed air at a tension p_m and an absolute temperature T_m be supplied from a reservoir (in which the loss is continually made good by an air-compressor). Neglecting the resistance of the port, its tension and temperature when behind the piston are still p_m and T_m . Let x_n = length of stroke, and let the cut-off (or closing of communication with the reservoir) be made at some point D where $x = x_m$, the position of D being so chosen (i.e., the ratio $x_m : x_n$ so computed) that after adiabatic expansion from D to E the pressure shall have fallen from p_m at M (state m) to a value $p_n = p_a$

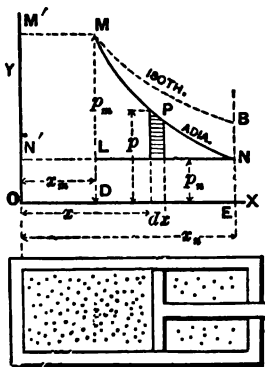

FIG. 529.

= one atmosphere at N (state n), at the end of stroke; so that when the piston returns the air will be expelled ("exhausted") at a tension equal to that of the external atmosphere (though at a low temperature). Hence the back-pressure at all points either way will be $= p_n$ per unit area of piston, and hence the total back-pressure $= Fp_n$, F being the piston area.

From O to D the forward pressure is constant and $= Fp_m$, and the effective work, therefore, or work on piston-rod from O to D , is

$$\text{Work of entrance} = \int_0^D W = F[p_m - p_n]x_m, \quad \dots (1)$$

represented by the rectangle $M'MLN'$. The cut-off being made at D , the volume of gas now in the cylinder, viz., $V_m = Fx_m$, is left to expand. Assuming no device adopted (such as injecting hot-water spray) for preventing the cooling and rapid decrease of tension during expansion, the latter is *adiabatic*, and hence the tension at any point P between M and N will be

$$p = p_m \left(\frac{x_m}{x} \right)^{\frac{1}{2}} \dots [\text{see } \S 478; V = Fx]; \dots (a)$$

\therefore Work of expansion

$$= \int_D^E W = \int_{x_m}^{x_n} F(p - p_n)dx = F \int_{x_m}^{x_n} p dx - Fp_n(x_n - x_m), \quad (2)$$

and is represented by the area $MPNL$.

$$\text{But } \int_{x_m}^{x_n} p dx = p_m x_m^{\frac{1}{2}} \int_{x_m}^{x_n} x^{-\frac{1}{2}} dx = -2p_m x_m^{\frac{1}{2}} \left[\left(\frac{1}{x_n} \right)^{\frac{1}{2}} - \left(\frac{1}{x_m} \right)^{\frac{1}{2}} \right];$$

$$\text{i.e., } F \int_{x_m}^{x_n} p dx = 2Fp_m x_m \left[1 - \left(\frac{x_m}{x_n} \right)^{\frac{1}{2}} \right]. \quad \dots (3)$$

Now substitute (3) in (2) and then add (2) to (1), noting that

$$F(p_m - p_n)x_m - Fp_n(x_n - x_m) = Fp_mx_m \left[1 - \frac{x_n p_n}{x_m p_m} \right],$$

which furthermore, since n and m are adiabatically related [see (a)], can be reduced to

$$Fp_mx_m \left[1 - \left(\frac{x_m}{x_n} \right)^{\frac{1}{\gamma}} \right],$$

and we have finally :

$$\left. \begin{array}{l} \text{Total work on piston} \\ \text{rod per stroke} \end{array} \right\} = W = 3Fp_mx_m \left[1 - \left(\frac{x_m}{x_n} \right)^{\frac{1}{\gamma}} \right]. \quad (4)$$

But $Fx_m = V_m$, and the adiabatic relation holds good,

$$\left(\frac{V_m}{V_n} \right)^{\frac{1}{\gamma}} = \left(\frac{p_n}{p_m} \right)^{\frac{1}{\gamma}}; \text{ i.e., } \left(\frac{x_m}{x_n} \right)^{\frac{1}{\gamma}} = \left(\frac{p_n}{p_m} \right)^{\frac{1}{\gamma}};$$

therefore we may also write

$$W = 3 V_m p_m \left[1 - \left(\frac{p_n}{p_m} \right)^{\frac{1}{\gamma}} \right]; \dots (5)$$

in which V_m = the volume which the mass of air used per stroke occupies in the *state m*, i.e., in the reservoir, where the tension is p_m and the absolute temperature = T_m .

To find the *work done per pound of air used* (or other unit of weight), we must divide W by the weight $G = V_m \gamma_m$ of the air used per stroke, remembering (eq. (13), § 472) that

$$V_m \gamma_m = [V_m p_m \gamma_o T_o] \div (T_m p_o).$$

$$\left. \begin{array}{l} \text{Work per unit of weight of} \\ \text{air used in adiabatic working} \end{array} \right\} = 3 T_m \frac{p_o}{\gamma_o T_o} \left[1 - \left(\frac{p_n}{p_m} \right)^{\frac{1}{\gamma}} \right]. \quad (6)$$

The back-pressure $p_n = p_a =$ one atmosphere.

In (6) $\gamma_o = .0807$ lbs. per cub. foot, $p_o = 14.7$ lbs. per sq. inch, and $T = 273^\circ$ Abs. Cent. or 492° Abs. Fahr.

It is noticeable in (6) that for given tensions p_m and p_n , the work per unit of weight of air used is *proportional to the absolute temperature T_m of the reservoir*. The temperature T_n to which the air has cooled at the end of the stroke is obtained as in Example 2, § 478, and may be far below freezing-point unless T_m is very high or the ratio of expansion, $x_m : x_n$, large.

EXAMPLE.—Let the cylinder of a compressed-air engine have a section of $F = 108$ sq. in. and a stroke $x_n = 15$ inches. The compressed air entering the cylinder is at a tension of 2 atmos. (i.e., $p_m = 29.4$ lbs. per sq. in., and $p_n \div p_m = \frac{1}{2}$), and at a temperature of 27° Cent. (i.e., $T_m = 300^\circ$ Abs. Cent.). Required the proper point of cut-off, or $x_m = ?$, in order that the tension may fall to one atmosphere at the end of the stroke; also the work per stroke, and the work per pound of air. Use the *foot, pound, and second*.

From eq. (a), above, we have

$$x_m = x_n \left(\frac{p_n}{p_m} \right)^{\frac{1}{3}} = 1.25 \sqrt[3]{\frac{1}{4}} = 0.7875 \text{ ft.} = 9.45 \text{ inches,}$$

and hence the volume of air in state m , used per stroke [eq. (5)] is

$$V_m = Fx_m = \frac{108}{12} \times 0.7875 = 0.5906 \text{ cubic feet;}$$

while the work per stroke is

$$W = 3 \times 0.5906 \times 29.4 \times 144 \times \left[1 - \left(\frac{1}{2} \right)^{\frac{1}{3}} \right] = 1545 \text{ ft. lbs.,}$$

and the work obtained from each pound of air, eq. (6),

$$= 3 \times 300 \times \frac{14.7 \times 144}{0.0807 \times 273} \times \left[1 - \sqrt[3]{\frac{1}{2}} \right] = 17810$$

ft. lbs. per pound of air used.

The temperature to which the air has cooled at the end of stroke [eq. (2), § 478] is

$$T_n = T_m \sqrt[3]{\frac{p_n}{p_m}} = 300 \times \sqrt[3]{\frac{1}{1.25}} = 300 \times .794 = 238^\circ \text{ Abs. C.};$$

i.e., $- 35^\circ$ Centigrade.

482. **Remarks on the Preceding.**—This low temperature is objectionable, causing, as it does, the formation and gradual accumulation of snow, from the watery vapor usually found in small quantities in the air, and the ultimate blocking of the ports. By giving a high value to T_m , however, i.e., by heating the reservoir, T_n will be correspondingly higher, and also *the work per pound of air*, eq. (6). If the cylinder be encased in a “jacket” of hot water, or if spray of hot water be injected behind the piston during expansion, the temperature may be maintained nearly constant, in which event Mariotte’s law will hold for the expansion, and more work will be obtained per pound of air; but the point of cut-off must be differently placed. Thus if, in eq. (4), § 479, we make the back-pressure, which $= (Fa \div Fl)p_b$, equal to the value to which the air-pressure has fallen at the end of the stroke by Mariotte’s law, we have

$$\left. \begin{array}{l} \text{Work per stroke with} \\ \text{isotherm. expans.} \end{array} \right\} = Fap_b \log_e \left(\frac{l}{a} \right) = V_b p_b \log_e \left(\frac{l}{a} \right), \quad (1)$$

and hence

$$\left. \begin{array}{l} \text{Work per unit of weight of air,} \\ \text{with isothermal expansion} \end{array} \right\} = T_m \frac{p_b}{\gamma_a T_a} \log_e \left(\frac{l}{a} \right). \quad (2)$$

Applying these equations to the data of the example, we obtain

$$\left. \begin{array}{l} \text{Work per unit of weight of air with iso-} \\ \text{thermal expansion} \end{array} \right\} = 0.69 T_m \frac{p_b}{\gamma_a T_a};$$

$$\left. \begin{array}{l} \text{whereas, with adiabatic expansion, work} \\ \text{per unit of weight of air is only} \end{array} \right\} = 0.62 T_m \frac{p_b}{\gamma_a T_a}.$$

483. Double-acting Air-compressor, with Adiabatic Compression.—This is the converse of § 481. In Fig. 530 we have the piston moving from right to left, compressing a mass of air which at the beginning of the stroke fills the cylinder.

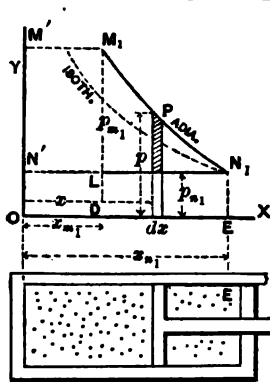

FIG. 530.

This is brought about by means of an external motor (steam-engine or turbine, e.g.) which exerts a thrust or pull along the piston-rod, enabling it with the help of the atmospheric pressure of the fresh supply of air flowing in behind it, to first *compress* a cylinder-full of air to the tension of the compressed air in the reservoir, and then, the port or valve opening at this stage, to force or *deliver* it into the reservoir. Let the temperature and tension of the cylinder-full of fresh air be T_n and p_n , and the tension in the reservoir be p_{m_1} . Suppose the compression adiabatic. As the piston passes from E toward the left, the air on the left has no escape and is compressed, its tension and temperature increasing adiabatically until it reaches a value p_{m_1} , = that in reservoir, at which instant, the piston being at some point D , a valve opens and the further progress of the piston simply transfers the compressed air into the reservoir without further increasing its tension. Throughout the whole stroke the piston-rod has the help of one atmosphere pressure on the right face, since a new supply of air is entering on the right to be compressed in its turn on the return stroke. The work done from E to D may be called the *work of compression*; that from D to O , the *work of delivery*.

[Since, here, dx and dW (or increment of work) have contrary signs, we introduce the negative sign as shown.]

$$\text{The work of compression} = - \int_E^D F(p - p_{n_1}) dx. \dots (1c)$$

$$\text{The work of delivery} = - \int_D^O F(p_{m_1} - p_{n_1}) dx. \dots (1c_2)$$

In these equations only p and α are variables. In the summation indicated in (1c) p changes adiabatically; in (1d) p is constant = p_m , as now written.

In the adiabatic compression the air passes from the state n_1 to the state m_1 (see N_1 and M_1 in figure).

The summations in these equations being of the same form as those in equations (1) and (2) of § 481, but with limits inverted, we may write immediately,

$$\text{Work per stroke} = W = 3 V_{m_1} p_{m_1} \left[1 - \left(\frac{p_{n_1}}{p_{m_1}} \right)^{\frac{1}{\gamma}} \right] \dots (2)$$

and

$$\left. \begin{array}{l} \text{Work per unit of weight} \\ \text{of air compressed} \end{array} \right\} = 3 T_{m_1} \frac{p_0}{\gamma_0 T_0} \left[1 - \left(\frac{p_{n_1}}{p_{m_1}} \right)^{\frac{1}{\gamma}} \right] \dots (3)$$

The value of T_{m_1} , at the immediate end of the sudden compression, by eq. (2) of § (478), is

$$T_{m_1} = T_{n_1} \left(\frac{p_{m_1}}{p_{n_1}} \right)^{\frac{1}{\gamma}} \dots \dots \dots (4)$$

The temperature of the reservoir being T_m , as in § 481 (usually much less than T_{m_1}), the compressed air entering it cools down gradually to that temperature, T_m , contracting in volume correspondingly since it remains at the same tension p_{m_1} . The mechanical equivalent of this heat is lost.

Let us now inquire what is the *efficiency of the combination* of air-compressor and compressed-air engine, the former supplying air for the latter, both working adiabatically, assuming that no tension is lost by the compressed air in passing along the reservoir between, i.e., that $p_{m_1} = p_m$. Also assume (as already implied, in fact) that $p_{n_1} = p_n =$ one atmos., and that the temperature, T_{n_1} , of the air entering the compressor cylinder is equal to that, T_m , of the reservoir and transmission-pipe.

To do this we need only find the ratio of the amount of work obtained from one pound (or other unit of weight) in the compressed-air engine to the amount spent in compressing one pound of air in the compressor. Calling this ratio η , the

efficiency, and dividing eq. (6) of § 481 by eq. (3) of this paragraph, we have, with substitutions just mentioned,

$$\eta = \frac{T_m}{T_{m_1}} = \frac{\text{Abs. temp. of outer free air}}{\left\{ \begin{array}{l} \text{Abs. temp. of air at end} \\ \text{of sudden compression,} \end{array} \right\}}; \dots (5)$$

or, substituting from eq. (4), and remembering that $T_{n_1} = T_m$, we have also

$$\eta = \left(\frac{p_n}{p_m} \right)^{\frac{1}{2}}; \dots \dots \dots (6)$$

also, since

$$\left(\frac{p_n}{p_m} \right)^{\frac{1}{2}} = \frac{T_n}{T_m},$$

we may write

$$\eta = \frac{T_n}{T_m} = \frac{\text{Ab. tem. air leaving eng. cyl.}}{\text{Ab. tem. outer free air.}} \dots (7)$$

For practical details of the construction and working of engines and compressors, and the actual efficiency realized, the student may consult special works, as they lie somewhat beyond the scope of the present work.

EXAMPLE 1.—In the example of § 445, the ratio of p_n to p_m was $= \frac{1}{2}$. Hence, if compressed air is supplied to the reservoir under above conditions, the efficiency of the system is, from eq. (6), $\eta = \sqrt{\frac{1}{2}} = 0.794$, about 80 per cent.

EXAMPLE 2.—If the ratio of the tensions is as small as $\frac{p_n}{p_m} = \frac{1}{6}$, the efficiency would be only $(\frac{1}{6})^{\frac{1}{2}} = 0.55$; i.e., 45 per cent of the energy spent in the compressor is lost in heat.

EXAMPLE 3.—What horse-power is required in a blowing engine to furnish 10 lbs. of air per minute at a pressure of 4 atmos., with adiabatic compression, the air being received by the compressor at one atmosphere tension and 27° Cent. (ft.-lb.-sec. system). Since 27° C. = 300° Abs. C. = T_n , we have, from eq. (4),

$$T_{m_1} = 300 (4)^{\frac{1}{2}} = 477^\circ \text{ Abs. Cent.};$$

and hence, eq. (3),

$$\text{The work per pound of air} = 3 \times 477 \frac{14.7 \times 144}{.0807 \times 273} \left[1 - \left(\frac{1}{4} \right)^{\frac{1}{\gamma}} \right]$$

= 50870 ft. lbs. per pound of air. Hence 10 lbs. of air will require 508700 ft. lbs. of work; and if this is done every minute we have the req. H. P. = $\frac{508700}{33000} = 15.4$ H. P.

NOTE.—If the compression could be made *isothermal*, an approximation to which is obtained by injecting a spray of cold water, we would have, from eqs. (1) and (2) of § 482:

$$\left. \begin{array}{l} \text{Work per} \\ \text{lb. air} \end{array} \right\} = T_m \frac{p_0}{\gamma_0 T_0} \log_e \left(\frac{p_{m_1}}{p_{n_1}} \right) = \frac{300 \times 14.7 \times 144}{.0807 \times 273} \times 1.386$$

= 39950 ft. lbs. per lb., and the corresponding H. P. = 12.1; a saving of about 25 per cent, compared with the former. The difference was employed in heating the air in the air-compressor with adiabatic compression, and was lost when that extra heat was dissipated in the reservoir as the air cooled again. This difference is easily shown graphically by comparing in the same diagram the areas representing the work done in the two cases.

484. Hot-air Engines.—Since we have seen that the tension of air and other gases can be increased by heating, if the volume be kept the same, a mass of air thus treated can afterwards be allowed to expand in a working cylinder, and thus become a means of converting heat into work. In *Stirling's* hot-air engine a definite confined mass of air is used indefinitely without loss (except that occasional small supplies are needed to make up for leakage), and is alternately heated and cooled. A displacement-plunger, or piston, fitting loosely in a bell-like chamber, is so connected with the piston of the working cylinder and the fly-wheel, that its forward stroke is made while the other piston waits at the beginning of its stroke. In this motion the plunger causes the confined air to pass in a thin sheet over the top and sides of the furnace dome, thus greatly increasing its tension. The air then expands behind the working piston with falling tension and temperature, and,

while that piston pauses at the end of its forward stroke, is again shifted in position, though without change of volume, by the return stroke of the plunger, in such a way as to pass through a coil of pipes in which cold water is flowing. This reduces both its temperature and tension, and hence its resistance to the piston on the return stroke is at first less than atmospheric, but is gradually increased by the compression. This cycle of changes is repeated indefinitely, and is easily traced on a diagram like that in Fig. 528, and computations made accordingly.

A special invention of Stirling's is the "*regenerator*" or box filled with numerous sheets of wire gauze, in its passage through which the working air, after expansion, deposits some of its heat, which it *re-absorbs* to some extent when, after further cooling in the "*refrigerator*" or pipe coil and compression by the return stroke of the piston, it is made to pass backward through the regenerator to be further heated by the furnace in readiness for a forward stroke. This feature, however, has not realized all the expectations of its inventor and improvers, as to economy of heat and fuel.

In *Ericsson's* hot-air engine, of more recent date, the displacement-plunger fits its cylinder air-tight, but valves can be opened through its edges when moving in one direction, thus causing it to act temporarily as a loose plunger, or shifter. The two pistons move simultaneously in the same direction in the same cylinder, but through different lengths of stroke, so that the space between them is alternately enlarged and contracted. The working piston also has valves opening through it for receiving a fresh supply of air into the space between the two pistons. During the forward stroke a fresh instalment from the outer air enters through the working piston into the space between it and the other, whose valves are now closed and which is now expelling from its further face, through proper valves, the air used in the preceding stroke; no work is done in this stroke. On the return stroke this fresh supply of air is free to expand behind the now retreating working piston, while its tension is greatly increased by its being shifted (at least a large portion of it) over the furnace

dome through the valves (now open) of the plunger piston, by the motion of the latter, which now acts as a loose plunger. The engine is therefore only single-acting, no work being done in each forward stroke. For further details, see Goodeve's and Rankine's works on the steam-engine; also the article "Hot-air Engine" in Johnson's Cyclopædia by Pres. Barnard, and Röntgen's Thermodynamics.

485. Brayton's Petroleum-engine.—Although a more recent invention than the gas-engines to be mentioned presently, this motor is more closely related to hot-air engines than the latter. By a *slow* combustion of petroleum vapor the gaseous products of combustion, while under considerable tension, are enabled to follow up a piston with a sustained pressure, being left to expand through the latter part of the stroke. Thus we have the furnace and working cylinder combined in one. The gradual combustion is accomplished by making use of the principle of the Davy safety-lamp that flame will not spread through layers of wire gauze of proper fineness.

486. Gas-engines.—We again have the furnace and working cylinder in one in a "*gas-engine*," where illuminating gas and atmospheric air are introduced into the working cylinder in proper proportions (about ten parts of air to one of gas, by weight) to form an explosive mixture of more or less violence and exploded at a certain point of the stroke, causing a very sudden rise of temperature and tension, after which the mass expands behind the piston with falling pressure. On the return stroke the products of combustion are expelled, and no work done, these engines being single-acting. In some forms the mixture is compressed before explosion, since it has been found that under this treatment a mixture containing a larger proportion of air to gas can be made to ignite, and that then the resulting pressure is more gradual and sustained, like that of steam or of the mixture in the Brayton engine. That is, the effect is analogous to that of "slow-burning powder" in a gun.

In the "Otto Silent Gas-engine" the explosion occurs only every fourth stroke, and one side of the piston is always open

to the air. The action on the other side of the piston is as follows: (1) In the forward stroke a fresh supply of explosive mixture is drawn into the cylinder at one atmosphere tension. (2) The next (backward) stroke compresses the mixture into about one fourth of its original bulk, this operation occurring at the expense of the kinetic energy of the fly-wheel. (3) The mixture is ignited, the pressure rises to 8 or 10 atmospheres, and work is done on the piston through the next (forward) stroke, the tension of the products of combustion having fallen to about two atmospheres at the end of the stroke. (4) In the next (backward) stroke the products of combustion are expelled and no work is done.

The Atkinson "Cycle Gas-engine," an English invention of recent date (see the *London Engineer* for May 1887; pp. 361 and 380) also makes an explosion every fourth stroke, but the link work connecting the piston and fly-wheel is of such design that the latter makes but one revolution during the four strokes. Also the length of the expansion or working stroke is greater than that of the compression stroke and the products of combustion are *completely expelled*. Consequently the efficiency of this motor is at present greater than that of any other gas-engine. See § 487.

One of the most simple gas-engines is made by the Economic Motor Company of New York. The piston has no packing, being a long plunger ground to fit the cylinder accurately and kept well lubricated. As with most gas-engines the cylinder is encased in a water-jacket to prevent excessive heating of the working parts and consequent decomposition of the lubricant.

For further details on these motors, see Rankine's "Steam-engine," Clark's "Gas-engines" in Van Nostrand's Science Series, and article "Gas-engine" in Johnson's Cyclopædia; also Prof. Thurston's report on Mechanical Engineering at the Vienna Exhibition of 1873, and proceedings of the "Society of Engineers" (England) for 1881.

487. Efficiency of Heat-engines.—According to the mechanical theory of heat, the combustion of one pound of coal, pro-

ducing, as it does, about 14,000 heat-units (British Thermal units; see § 149, Mechanics) should furnish

$$14,000 \times 772 = 10,808,000 \text{ ft. lbs. of work,}$$

if entirely converted into work. Let us see how nearly this is accomplished in the performance of the most recent and economical marine engines of the present day, viz., the triple expansion engines of some Atlantic steamers, which are claimed to have consumed per hour only 1.25 lbs. of coal for each measured ("indicated") horse-power of effective work done in their cylinders. The work-equivalent of 1.25 lbs. of coal per hour is

$$1.25 \times 14,000 \times 772 = 13,510,000 \text{ ft. lbs. per hour;}$$

while the actual work per hour implied in "one H. P. per hour" is

$$33000 \times 60 = 1,980,000 \text{ ft. lbs. per hour.}$$

That is, the engines utilize only *one seventh* of the heat of combustion of the fuel.

According to Prof. Thurston, this is a rather extravagant claim (1.25), the actual consumption having probably been 1.4 lbs. of coal per H. P. per hour.

The ordinary compound marine engine is stated to use as little as 2.00 lbs. per hour for each H. P.

Most of the heat not utilized is dissipated in the condenser.

Similarly, the water-jacket, a necessary evil in the operation of the gas-engine, is a source of great loss of heat and work. Still, Mr. Wm. Anderson in his recent work, "Conversion of Heat into Work" (London, 1887), mentions a motor of this class as having converted into work $\frac{1}{4}$ of the heat of combustion [an Otto "Silent Gas-engine," tested at the Stevens Institute, Hoboken, N. J., in 1883]; while Prof. Unwin found the Atkinson engine (see last paragraph) capable of returning (in the cylinder) fully $\frac{1}{4}$ of the heat-equivalent of the gas consumed. [This latter result was confirmed in Philadelphia in Jan. 1889 by Prof. Barr, under direction of Prof. Thurston.]

488. Duty of Pumping-engines.—Another way (often used in speaking of the performance of pumping-engines) of expressing the degree of economy attained in the use of fuel by the combined furnace, boiler, and engine is to give the number of foot-pounds of work obtained from each 100 lbs. of coal consumed in the furnace, calling it the “*duty*” of the engine.

For example, by a duty of 99,000,000 ft. lbs. it is meant that from each pound of coal 990,000 ft. lbs. of work are obtained. From this we gather that, since one horse-power consists of $33,000 \times 60 = 1,980,000$ ft. lbs. per hour, the engine mentioned must use each hour

$$1,980,000 \div 990,000 = 2 \text{ lbs. of coal for each H. P. developed;}$$

which is as low a figure as that attained by the marine engines last quoted.

489. Buoyant Effort of the Atmosphere.—In the case of a body of large bulk but of small specific gravity the buoyant effort of the air (due to the same cause as that of water, see § 456) becomes quite appreciable, and may sometimes be greater than the weight of the body. This buoyant effort is equal to the weight of air displaced, i.e., $= V\gamma$, where V is the volume of air displaced, and γ its heaviness.

If G_1 = total weight of the body producing the displacement, the resultant vertical force is

$$P = G_1 - V\gamma, \dots \dots \dots (1)$$

and for equilibrium, or *suspension in the air*, we must have $P = 0$, i.e.,

$$G_1 = V\gamma. \dots \dots \dots (2)$$

We may therefore find approximately the elevation where a given balloon will cease to ascend, by determining the heaviness γ of the air at that elevation from eq. (2); then, knowing approximately the temperature of the air at that elevation, we may compute its tension p [eq. (13), § 472], and finally, from eqs. (3), (4), or (5) of § 477, obtain the altitude required.

EXAMPLE.—The car and other solid parts of a balloon weigh

400 lbs., and the bag contains 12,000 cub. feet of illuminating gas weighing 0.030 lb. per cub. foot at a tension of one atmosphere and temperature of 15° Cent., so that its total weight = $12,000 \times 0.030 = 360$ lbs.

Hence $G_1 = 760$ lbs. We may also write with sufficient accuracy: Whole volume of displacement = $V = 12,000$ cub. ft.

As the balloon ascends the exterior pressure diminishes, and the confined gas tends to expand and so increase the volume of displacement V ; but this we shall suppose prevented by the strength of the envelope. At the surface of the ground (station n of Fig. 531; see also Fig. 526) let the barometer read 29.6 inches and the temperature be 15° Cent. Then $T_n = 288^\circ$ Abs. Cent., and the heaviness of the air at n is

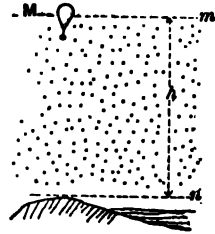

FIG. 531.

$$\gamma_n = \frac{.0807 \times 273}{14.7} \cdot \frac{29.6}{30} \times 14.7$$

$$\left(= \frac{\gamma_n T_n p_n}{p_n T_n} \right) = .0807 \times \frac{273}{288} \cdot \frac{29.6}{30} = .0754 \text{ lbs. per cub. ft.}$$

At the unknown height h , where the balloon is to come to rest, i.e., at M , G_1 must = $V\gamma$ [eq. (2)]; therefore

$$\gamma_m = \frac{G_1}{V} = \frac{760 \text{ lbs.}}{12,000 \text{ cub. ft.}} = .0633 \text{ lbs. per cub. ft. ;}$$

and if the temperature at M be estimated to be 5° Cent. (or $T_m = 278^\circ$ Abs. Cent.) (on a calm day the temperature decreases about 1° Cent. for each 500 ft. of ascent), we shall

have, from $\frac{p_m}{\gamma_m T_m} = \frac{p_n}{\gamma_n T_n}$,

$$\frac{p_n}{p_m} = \frac{\gamma_n T_n}{\gamma_m T_m} = \frac{.0754}{.0633} \cdot \frac{288}{278} = 1.206 ;$$

and hence, from eq. (5), § 477, with $\frac{1}{2}(T_m + T_n)$ put for T_n ,

$$h = 26213 \times \frac{2}{3} \times 2.30258 \times \log_{10} 1.206 = 5088 \text{ ft.}$$

CHAPTER VI.

HYDRODYNAMICS BEGUN—STEADY FLOW OF LIQUIDS THROUGH PIPES AND ORIFICES.

489a. The subject of **Water in Motion** presents one of the most unsatisfactory branches of Applied Mechanics, from a mathematical stand-point. The internal eddies, cross-currents, and general intricacy of motion of the particles among each other, occurring in a pipe transmitting a fluid, are almost entirely defiant of mathematical expression, though the flow of water through a circular orifice in a thin plate into the air presents a simpler case, where the conception of "stream lines" is probably quite close to the truth. In most practical cases we are forced to adopt as a basis for mathematical investigation the simple assumption that the particles move side by side in such a way that those which at any instant form a lamina or thin sheet, \perp to the axis of the pipe or orifice, remain together as a lamina during the further stages of the flow. This is the Hypothesis of Flow in Plane Layers, or Laminated Flow. Experiment is then relied on to make good the discrepancies between the indications of the formulæ resulting from this theory and the actual results of practice; so that the science of Hydrodynamics is largely one of coefficients determined by experiment.

490. Experimental Phenomena of a "Steady Flow."—As preliminary to the analysis on which the formulæ of this chapter are based, and to acquire familiarity with the quantities involved, it will be advantageous to study the phenomena of the apparatus represented in Fig. 532. A large tank or reservoir BC is connected with another, DE , at a lower level, by means of a rigid pipe opening under the water-level in each tank. This

pipe has no sharp curves or bends, is of various sectional areas at different parts, the changes of section being very gradual, and the highest point N , not being more than 30 ft. higher than BC , the surface-level of the upper tank. Let both tanks

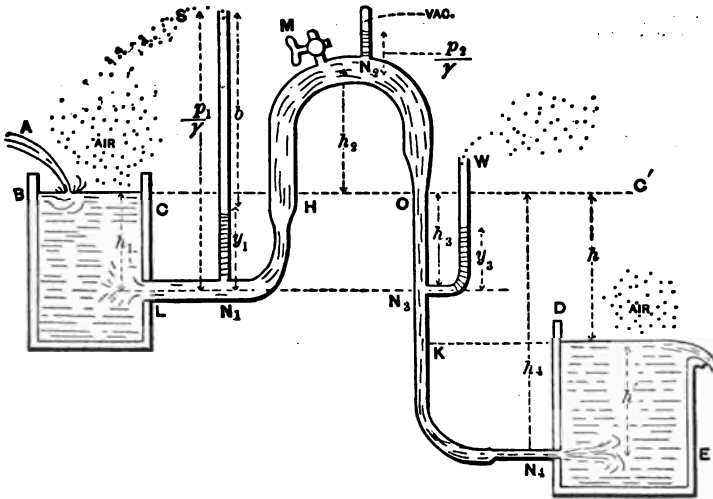

FIG. 532.

be filled with water (or other liquid), which will also rise to H and to K in the pipe. Stop the ends L and N_1 of the pipe, and through M , a stop-cock in the highest curve, pour in water to fill the remainder of the pipe; then, closing M , unstop L and N_1 .

If the dimensions are not extreme (and subsequent formulæ will furnish the means of testing such points) the water will now begin to flow from the upper tank into the lower, and all parts of the pipe will continue full of water as the flow goes on.

Further, suppose the upper tank *so large that its surface-level sinks very slowly*; or that an influx at A continually makes good the efflux at E ; then the flow is said to be a **Steady Flow**; or, a *state of permanency* is said to exist; i.e., the circumstances of the flow at each section of the pipe are *permanent, or steady*.

By measuring the volume, V , of water discharged at E in a time t , we obtain the *volume of flow per unit of time*, viz.,

$$Q = \frac{V}{t}, \dots \dots \dots (1)$$

while the *weight of flow* per unit of time is

$$G = Q\gamma, \dots \dots \dots (2)$$

where γ = heaviness (§ 7) of the liquid concerned.

Water being incompressible and the pipe rigid, it follows that the same volume of water per unit of time must be passing at each cross-section of the pipe. But this is equal to the volume of a prism of water having F , the area of the section, as a base, and, as an altitude, the mean velocity = v with which the liquid particles pass through the section. Hence for any section we have

$$Q = Fv = \text{constant} = F_1v_1 = F_2v_2, \text{ etc. } \left\{ \begin{array}{l} \text{Equat. of} \\ \text{continuity} \end{array} \right\}, \dots (3)$$

in which the subscripts refer to different sections. If the flow were *unsteady*, e.g., if the level BC were sinking, this would be true for a definite instant of time; but when *steady*, we see that it is permanently true; e.g., F_1v_1 at any instant = F_2v_2 at the same or *any other* instant, subsequent or previous. In other words, *in a steady flow the velocity at a given section remains unchanged with lapse of time.*

[N.B. We here assume for simplicity that the different particles of water passing simultaneously through a given section (i.e., abreast of each other) have equal velocities, viz., the velocity which all other particles will assume on reaching this section. Strictly, however, the particles at the sides are somewhat retarded by friction on the surface of the pipe. This assumption is called the *Assumption of Parallel Flow*, or *Flow in Plane Layers*, or *Laminated Flow*.]

Let us suppose Q to have been found as already prescribed. We may then, knowing the internal sectional areas at different parts of the pipe, N_1 , N_2 , etc., compute the velocities

$$v_1 = Q \div F_1, \quad v_2 = Q \div F_2, \quad \text{etc.,}$$

which the water must have in passing those sections, respectively. It is thus seen that the velocity at any section has no direct connection with the height or depth of the section from the plane, BC , of the upper reservoir surface. The fraction $\frac{v^2}{2g}$ will be called the *height due to the velocity, v* , or simply the *velocity-head*, for convenience.

Next, as to the value of the internal fluid pressure, p , per unit-area (in the water itself and against the side or wall of pipe) at different sections of the pipe. If the end N_1 of the pipe were stopped, the problem would be one in Hydrostatics, and the pressure against the side of the pipe at N_1 (also at N_1 , on same level) would be simply

$$p_1 = p_a + h_1 \gamma,$$

measured by a water column of height

$$\frac{p_1}{\gamma} = \frac{p_a}{\gamma} + h_1 = b + h_1,$$

in which $p_a =$ one atmosphere, and $b = 34$ ft. = height of an ideal water barometer, and $\gamma = 62.5$ lbs. per cubic foot; and this would be shown experimentally by screwing into the side of the pipe at N_1 a small tube open at both ends; the water would rise in it to the level BC . That is, a column of water of height $= h_1$ would be sustained in it, which indicates that the internal pressure at N_1 corresponds to an ideal water column of a height

$$= \frac{p_1}{\gamma} = b + h_1.$$

But when a steady flow is proceeding, the case being now one of Hydrodynamics, we find the column of water sustained at rest in the small tube (called an *open piezometer*) N_1S has a height y_1 , less than h_1 , and hence the internal fluid pressure is

less than it was when there was no flow. This pressure being called p_1 , the ideal water column measuring it has a height

$$\frac{p_1}{\gamma} = b + y_1 \dots \dots \dots (4)$$

at N_1 , and will be called the *pressure-head* at the section referred to. We also find experimentally that while the flow is steady the piezometer-height y (and therefore the pressure-head $b + y$) at any section remains unchanged with lapse of time, as a characteristic of a steady flow.

[For correct indications, the extremity of the piezometer should have its edges flush with the inner face of the pipe wall, where it is inserted.]

At N_2 , although at the same level as N_1 , we find, on inserting an open piezometer, W , that with $F_2 = F_1$ (and therefore with $v_2 = v_1$) y_2 is a little less than y_1 ; while if $F_2 < F_1$ (so that $v_2 > v_1$) y_2 is not only less than y_1 , but the difference is greater than before. We have therefore found experimentally that, in a general way, when water is flowing in a pipe it presses less against the side of the pipe than it did before the flow was permitted, or (what amounts to the same thing) the pressure between the transverse laminae is less than the hydrostatic pressure would be.

In the portion HN_2O of the pipe we find the pressure less than one atmosphere, and consequently a manometer registering pressures from zero upward (and not simply the excess over one atmosphere, like the Bourdon steam-gauge and the open piezometer just mentioned) must be employed. At N_2 , e.g., we find the pressure

$$= \frac{1}{2} \text{ atmos.}, \text{ i.e., } \frac{p_2}{\gamma} = 17 \text{ ft.}$$

Even below the level BC , by making the sections quite narrow (and consequently the velocities great) the pressure may be made less than one atmosphere. At the surface BC the pressure is of course just one atmosphere, while that in the jet at N_2 , entering the right-hand tank under water, is necessarily $p_2 = 1 \text{ atmos.} + \text{press. due to col. } h' \text{ of water practically at rest;}$

i.e., $\frac{p_1}{\gamma} = \text{pressure-head at } N_1 = b + h'$;

(whereas if N_1 were stopped by a diaphragm, the pressure-head just on the right of the diaphragm would be $b + h'$, and that on the left $b + h_1$.)

Similarly, when a jet enters the atmosphere in parallel filaments its particles are under a pressure of one atmosphere, i.e., their pressure-head = $b = 34$ ft. (for water); for the air immediately around the jet may be considered as a pipe between which and the water is exerted a pressure of one atmosphere.

491. Recapitulation and Examples.—We have found experimentally, then, that in a steady flow of liquid through a rigid pipe there is at each section of the pipe a definite velocity and pressure which all the liquid particles assume on reaching that section; in other words, at each section of the pipe the liquid velocity and pressure remain constant with progress of time.

EXAMPLE 1.—If in Fig. 532, the flow having become steady, the volume of water flowing in 3 minutes is found on measurement to be 134 cub. feet, the volume per second is, from eq. (1), § 490,

$$Q = \frac{134}{180} = 0.744 \text{ cub. ft. per second.}$$

EXAMPLE 2.—If the flow in 2 min. 20 sec. is 386.4 lbs., the volume of flow per second is [ft., lb., sec.; eqs. (1) and (2)]

$$Q = \frac{V}{t} = \frac{G}{\gamma} \div t = \frac{386.4}{62.5} \cdot \frac{1}{140} = 0.0441 \text{ cub. ft. per sec.}$$

EXAMPLE 3.—In Fig. 532 the height of the open piezometer at N_1 is $y_1 = 9$ feet; what is the internal fluid pressure? [Use the inch, lb., and sec.] The internal pressure is

$$p_1 = p_a + y_1 \gamma = 14.7 + 108 \times \frac{9}{17.75} = 18.6 \text{ lbs. per sq. inch.}$$

The pressure on the outside of the pipe is, of course, one atmosphere, so that the resultant bursting pressure at that point (N_1) is 3.9 lbs. per sq. in.

EXAMPLE 4.—The volume of flow per second being .0441

cub. ft. per sec., as in Example 1, required the velocity at a section of the (circular) pipe where the diameter is 2 inches. [Use ft., lb., and sec.]

$$v = \frac{Q}{F} = \frac{0.0441}{\frac{1}{4}\pi\left(\frac{2}{12}\right)^2} = 2.02 \text{ ft. per sec.};$$

while at another section of the pipe where the diameter is four inches (double the former) and the sectional area, F , is therefore four times as great, the velocity is $\frac{1}{4}$ of $2.02 = 0.505$ ft. per sec.

492. Bernoulli's Theorem for Steady Flow; without Friction.—

If the pipe is comparatively short, without sudden bends, elbows, or abrupt changes of cross-section, the effect of friction of the liquid particles against the sides of the pipe and against each other (as when eddies are produced, disturbing the parallelism of flow) is small, and will be neglected in the present analysis, whose chief object is to establish a formula for steady flow through a short pipe and through orifices.

An assumption, now to be made, of *flow in plane layers*, or *laminated flow*, i.e., flow in laminae γ to the axis of the pipe at every point, may be thus stated: (see Fig. 533, which shows

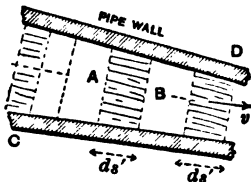

FIG. 533.

a steady flow proceeding, through a pipe CD of indefinite extent.) All the liquid particles which at any instant form a small lamina, or sheet, as AB , γ to axis of pipe, *keep company as a lamina throughout the whole flow.* The thickness, ds' , of this lamina remains constant so long as the pipe is of constant cross-section, but shortens up (as at C) on passing through a larger section, and lengthens out (as at D) in a part of the pipe where the section is smaller (i.e., the sectional area, F , is smaller). The mass of such a lamina is $Fds'\gamma \div g$ [§ 55], its velocity at any section will be called v (pertaining to that point of the pipe's axis), the pressure of the lamina just behind it is Fp , upon the rear face, while the resistance (at the same instant) offered by its neighbor just ahead is $F(p + dp)$ on the front face: also

its weight is the vertical force $Fds'\gamma$. Fig. 534 shows, as a free body, the lamina which at any instant is passing a point A of the pipe's axis, where the velocity is v and pressure p .

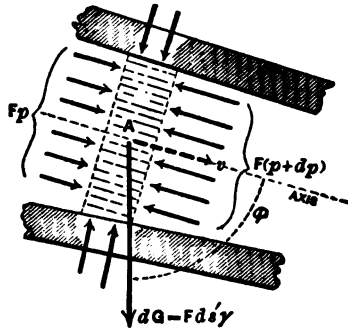

FIG. 534.

Note well the forces acting; the pressures of the pipe wall on the edges of the lamina have no components in the direction of v , for the wall is considered smooth, i.e., those pressures are \perp to wall; in other words, no friction is considered. To this free body apply eq. (7) of § 74, for any instant of any curvilinear motion of a material point

$$v dv = (\text{tang. acceleration}) \times ds, \dots (1)$$

in which ds = a small portion of the path, and is described in the time dt . Now the tang. accel. = $\Sigma(\text{tang. comps. of the acting forces}) \div$ mass of lamina, i.e.,

$$\text{tang. acc.} = \frac{Fp - F(p + dp) + Fyds' \cos \phi}{Fyds' \div g} \dots (2)$$

Now, Fig. 535, at a definite instant of time, conceive the volume of water in the pipe to be subdivided into a great number of laminae of equal mass (which implies equal volumes

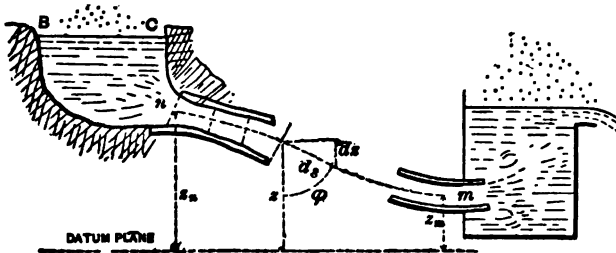

FIG. 535.

in the case of a liquid, but not with gaseous fluids), and let the ds just mentioned for any one lamina be the distance from its centre to that of the one next ahead; this mode of subdivision

makes the ds of any one lamina identical in value with its thickness ds' , i.e.,

$$ds = ds'. \quad \dots \dots \dots (3)$$

We have also

$$ds \cos \phi = -dz, \quad \text{or} \quad ds' \cos \phi = -dz; \dots (4)$$

z being the height of the centre of a lamina above any convenient horizontal datum plane. Substituting from (2), (3), and (4) in (1), we derive finally

$$\frac{1}{g} v dv + \frac{1}{\gamma} dp + dz = 0. \dots \dots \dots (5)$$

The flow being steady, and the subdivision into laminae being of the nature just stated, each lamina in some small time dt moves into the position which at the beginning of dt was filled by the lamina next ahead, and acquires the same velocity, the same pressures on its faces, and the same value of z , that the front lamina had at the beginning of dt .

Hence, considering the simultaneous advance made by all the laminae in this same dt , we may write out an equation like (5) for each of the laminae between any two cross-sections n and m of the pipe, thus obtaining an infinite number of equations, from which by adding corresponding terms, i.e., by integration, we obtain

$$\frac{1}{g} \int_{v_n}^{v_m} v dv + \frac{1}{\gamma} \int_{p_n}^{p_m} dp + \int_{z_n}^{z_m} dz = 0; \dots (6)$$

whence, performing the integrations and transposing,

$$\frac{v_m^2}{2g} + \frac{p_m}{\gamma} + z_m = \frac{v_n^2}{2g} + \frac{p_n}{\gamma} + z_n \dots \dots \left\{ \begin{array}{l} \text{Bernoulli's} \\ \text{Theorem} \end{array} \right\} \dots (7)$$

Denoting by *Potential Head* the vertical height of any section of the pipe above a convenient datum level, we may state Bernoulli's Theorem as follows:

In steady flow without friction, the sum of the velocity-head, pressure-head, and potential head at any section of the pipe is a constant quantity, being equal to the sum of the corresponding heads at any other section.

It is noticeable that in eq. (7) each of the terms is a linear quantity, viz., a height, or head, either actual, such as z_n and z_m , or ideal (all the others), and does not bring into account the absolute size of the pipe, nor even its relative dimensions (v_m and v_n , however, are connected by the equation of continuity $F_m v_m = F_n v_n$), and contains no reference to the volume of water flowing per unit of time [Q] or the shape of the pipe's axis. When the pipe is of considerable length compared with its diameter the friction of the water on the sides of the pipe cannot be neglected (§ 512).

It must be remembered that Bernoulli's Theorem does not hold unless the flow is *steady*, i.e., unless each lamina, in coming into the *position* just vacated by the one next ahead (of equal mass), comes also into the exact conditions of velocity and pressure in which the other was when in that position.

[N.B. This theorem can also be proved by applying to all the water particles between n and m , as a collection of small *rigid* bodies (water being incompressible) the theorem of Work and Energy for a collection of Rigid Bodies in § 142, eq. (xvi), taking the respective paths which they describe simultaneously in a single dt .]

493. First Application of Bernoulli's Theorem without Friction.

—Fig. 536 shows a large tank from which a vertical pipe of uniform section leads to another tank and dips below the surface of the water in the latter. Both surfaces are open to the air. The vessels and pipe being filled with water, and the lower end m of the pipe unstoppered, a steady flow is established almost immediately, the surface BC being very large compared with F , the area of the (*uniform*) section of the pipe.

Given F , and the heights h_0 and h , required the velocity v_m of the jet at m and also the pressure, p_n , at n (in pipe near entrance of same). m is in the jet, just clear of the pipe, and practically in the water-level, AD . The velocity v_m is unknown, but the pressure p_m is practically $= p_a =$ one atmosphere, since

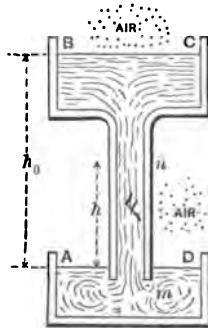

FIG. 536.

the pressure on the sides of the jet is necessarily the hydrostatic pressure due to a slight depth below the surface AD .

\therefore Press-head at m is $\frac{P_m}{\gamma} = \frac{P_n}{\gamma} = b = 34$ feet. . . (§ 423)

Now apply Bernoulli's Theorem to sections m and n , taking a horizontal plane through m as a datum plane for potential heads, so that $z_n = h$ and $z_m = 0$, and we have

$$\frac{v_m^2}{2g} + b + 0 = \frac{v_n^2}{2g} + \frac{P_n}{\gamma} + h. \quad (1)$$

But, assuming that the section of the pipe is filled at every point, we must have

$$v_m = v_n;$$

for, in the equation of continuity

$$F_m v_m = F_n v_n,$$

if we put $F_m = F_n$, the pipe being of uniform section, we obtain $v_m = v_n$. Hence eq. (1) reduces to

$$\frac{P_n}{\gamma} = b - h = 34 \text{ ft.} - h. \quad (2)$$

Hence the pressure at n is less than one atmosphere, and if a small tube communicating with an air-tight receiver full of air

were screwed into a small hole at n , the air in the receiver would gradually be drawn off until its tension had fallen to a value p_n . [This is the principle of *Sprengel's air-pump*, mercury, however, being used instead of water, as for this heavy liquid $b =$ only 30 inches.]

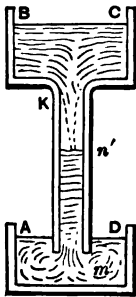

FIG. 537.

If h is made $> b$ for water, i.e. > 34 feet (or > 30 inches for mercury), p_n would be negative from eq. (2), which is impossible, showing that the assumption of full pipe-sections is not borne out. In this case, $h > b$, only a portion, mn' ,

(in length somewhat less than b), of the tube will be kept full

during the flow (Fig. 537); while in the part Kn' vapor of water, of low tension corresponding to the temperature (§ 469), will surround an internal jet which does not fill the pipe. As for the value of v_m , Bernoulli's Theorem, applied to BC and m , in Fig. 536, gives finally $v_m = \sqrt{2gh}$.

EXAMPLE.—If $h = 20$ feet, Fig. 536, and the liquid is water, the pressure-head at n is (ft., lb., sec.)

$$\frac{P_n}{\gamma} = b - h = 34' - 20' = 14 \text{ ft.},$$

and therefore

$$p_n = 14 \times 62.5 = 875 \text{ lbs. per sq. ft.} = 6.07 \text{ lbs. per sq. in.}$$

494. Second Application of Bernoulli's Theorem without Friction.—Knowing by actual measurement the open piezometer height y_n at the section n in Fig. 538 (so that the pressure-

head, $\frac{P_n}{\gamma} = b + y_n$, at n is

known); knowing also the vertical distance h_n from n to m , and the respective

cross-sections F_n and F_m (F_m being the sectional area of the jet, flowing into the air, so that $\frac{P_m}{\gamma} = b$), required the volume of flow per sec.; i.e., required Q , which

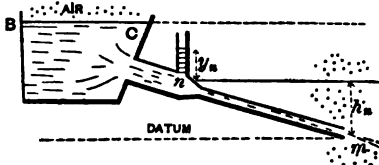

FIG. 538.

$$= F_n v_n = F_m v_m. \dots \dots \dots (1)$$

The pipe is short, with smooth curves, if any, and friction will therefore be neglected. From Bernoulli's Theorem [eq. (7), § 492], taking m as a datum plane for potential heads, we have

$$\frac{v_m^2}{2g} + b + 0 = \frac{v_n^2}{2g} + (y_n + b) + h_n. \dots \dots (2)$$

But from (1) we have

$$v_n = [F_m \div F_n] v_m;$$

substituting which in (2) we obtain, solving for v_m ,

$$v_m = \frac{\sqrt{2g(y_n + h_n)}}{\sqrt{1 - \left(\frac{F_m}{F_n}\right)^2}}, \dots \dots \dots (3)$$

and hence the volume per unit of time becomes known, viz.,

$$Q = F_m v_m. \dots \dots \dots (4)$$

NOTE.—If the cross-section F_m of the nozzle, or jet, is $> F_n$, v_m becomes imaginary (unless y_n is *negative* (i.e., $p_n < \text{one atmos.}$), and numerically $> h_n$); in other words, the assigned cross-sections are *not filled by the flow*.

EXAMPLE.—If $y_n = 17$ ft. (thus showing the internal fluid pressure at n to be $p_n = \gamma(y_n + b) = 1\frac{1}{2}$ atmos.), $h_n = 10$ ft., and the (round) pipe is 4 inches in diameter at n and 3 inches at the nozzle m , we have from (3) (using ft.-lb.-sec. system of units in which $g = 32.2$)

$$v_m = \frac{\sqrt{2 \times 32.2(17 + 10)}}{\sqrt{1 - \left[\frac{\frac{1}{4}\pi 3^2}{\frac{1}{4}\pi 4^2}\right]^2}} = 50.4 \text{ ft. per sec.}$$

[N.B. Since $F_m \div F_n$ is a ratio and therefore an abstract number, the use of the inch in the ratio will give the same result as that of the foot.]

Hence, from (4),

$$Q = F_m v_m = \frac{1}{4}\pi\left(\frac{3}{2}\right)^2 \times 50.4 = 2.474 \text{ cub. ft. per sec.}$$

495. Orifices in Thin Plate.—Fig. 539. When efflux takes place through an orifice in a thin plate, i.e., a *sharp-edged* orifice in the plane wall of a tank, a contracted vein (or “vena

contracta²) is formed, the filaments of water not becoming parallel until reaching a plane, m , parallel to the plane of vessel wall, which for circular orifices is at a distance from the interior plane of vessel wall equal to the radius of the circular aperture; and not until reaching this plane does the internal fluid pressure become equal to that of the surrounding medium (atmosphere, here), i.e., surrounding the jet. We assume that the width of the orifice is small compared with h , unless the vessel wall is horizontal.

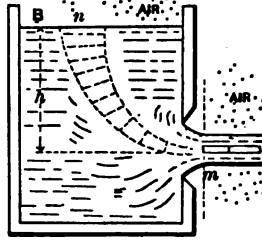

FIG. 539.

The area of the cross-section of the jet at m , called the *contracted section*, is found on measurement to be from .60 to .64 of the area of the aperture with most orifices of ordinary shapes, even with widely different values of the area of aperture and of the height, or head, h , producing the flow. Calling this abstract number [.60 to .64] the *Coefficient of Contraction*, and denoting it by C , we may write

$$F_m = CF,$$

in which F = area of the orifice, and F_m = that of the contracted section. C ranges from .60 to .64 with circular orifices, but may have lower values with some rectangular forms. (See table in § 503.)

A lamina of particles of water is under atmospheric pressure at n (the free surface of the water in tank or reservoir), while its velocity at n is practically zero, i.e. $v_n = 0$ (the surface at B being very large compared with the area of orifice). It experiences increasing pressure as it slowly descends until in the immediate neighborhood of the orifice, when its velocity is rapidly accelerated and pressure decreased, in accordance with Bernoulli's Theorem, and its shape lengthened out, until finally at m it forms a portion of a filament of a jet, its pressure is one atmosphere, and its velocity, $= v_m$, we wish to determine. The course of this lamina we call a

“*stream-line*,” and Bernoulli’s Theorem is applicable to it, just as if it were enclosed in a frictionless pipe of the same form. Taking then a datum plane through the centre of m , we have

$$\frac{p_m}{\gamma} = b, \quad z_m = 0, \quad \text{and} \quad v_m = ?;$$

while

$$\frac{p_n}{\gamma} \text{ also } = b, \quad z_n = h, \quad \text{and} \quad v_n = 0.$$

Hence Bernoulli’s Theorem gives

$$\frac{v_m^2}{2g} + b + 0 = 0 + b + h;$$

$$\therefore \frac{v_m^2}{2g} = h, \quad \dots \dots \dots (1)$$

and

$$v_m = \sqrt{2gh}.$$

That is, *the velocity of the jet at m is theoretically the same as that acquired by a body falling freely in vacuo through a height $= h =$ the “head of water.”* We should therefore expect that if the jet were directly vertically upward, as at m , Fig. 540,

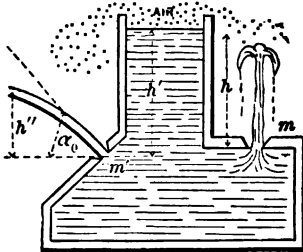

FIG. 540.

a height $\frac{v_m^2}{2g}$

would be actually attained. [See §§ 52 and 53.] Experiment shows that the height of the jet (at m) does not materially differ from h if

h is not > 6 or 8 feet. For $h > 8$ ft., however, the actual height reached is $< h$, the difference being not only absolutely but relatively greater as h is taken greater, since the resistance of the air is then more and more effective in depressing and breaking up the stream. (See § 578.)

At m' , Fig. 540, we have a jet, under a head $= h'$, directed

at an angle α , with the horizontal. Its form is a parabola (§ 81), and the theoretical height reached is $h'' = h' \sin^2 \alpha$, (§ 80).

The jet from an orifice in thin plate is very limpid and clear. From eq. (1), we have theoretically

$$v_m = \sqrt{2gh}$$

(an equation we shall always use for efflux *into the air* through *orifices* and *short pipes* in the plane wall of a large tank whose water-surface is very large compared with the orifice, and is open to the air), but experiment shows that for an "*orifice in thin plate*" this value is reduced about 3% by friction at the edges, so that for ordinary practical purposes we may write

$$v_m = \phi \sqrt{2gh} = 0.97 \sqrt{2gh}, \quad (2)$$

in which ϕ is called the *coefficient of velocity*.

Hence the volume of flow, Q , per time-unit will be

$$Q = F_m v_m = CF\phi \sqrt{2gh}, \text{ on the average} = 0.62F \sqrt{2gh}. \quad (3)$$

It is to be understood that the flow is steady, and that the reservoir surface (very large) and the jet are *both under atmospheric pressure*. ϕC is called the *coefficient of efflux*.

EXAMPLE 1.—Fig. 539. Required the velocity of efflux, v_m , at m , and the volume of the flow per second, Q , into the air, if $h = 21$ ft. 6 inches, the *circular* orifice being 2 in. in diam.; take $C = 0.64$. [Ft., lb., and sec.]

From eq. (2),

$$v_m = 0.97 \sqrt{2 \times 32.3 \times 21.5} = 36.1 \text{ ft. per sec.};$$

hence the discharge is

$$Q = F_m v_m = 0.64 \times \frac{\pi \left(\frac{2}{12}\right)^2}{4} \times 36.1 = 0.504 \text{ cub. ft. per second.}$$

EXAMPLE 2.—[Weisbach.] Under a head of 3.396 metres the velocity v_m in the contracted section is found by measure-

ments of the jet-curve to be 7.98 metres per sec., and the discharge proves to be 0.01825 cub. metres per sec. Required the coefficient of velocity (ϕ) and that of contraction (C), if the area of the orifice is 36.3 sq. centimetres.

Use the *metre-kilogram-second* system of units, in which $g = 9.81$ met. per sq. second.

From eq. (2),

$$\phi = \frac{v_m}{\sqrt{2gh}} = \frac{7.98}{\sqrt{2 \times 9.81 \times 3.396}} = 0.978;$$

while from (3) we have

$$C = \frac{Q}{F\phi\sqrt{2gh}} = \frac{Q}{Fv_m} = \frac{.01825}{.5033 \times 7.98} = 0.631.$$

ϕ and C , being abstract numbers, are independent of the system of concrete units adopted.

NOTE.—To find the velocity v_m of the jet at the orifice by measurements of the jet-curve, as mentioned in Example 2, we may proceed as follows: Since we cannot very readily assure ourselves that the direction of the jet at the orifice is horizontal, we consider the angle α , of the parabola (see Fig. 93 and § 80) as unknown, and therefore have two unknowns to deal with, and obtain the necessary two equations by measuring the x and y (see page 84) of two points of the jet, remembering that if we use the equation (3) of page 84 in its present form points of the jet below the orifice will have negative y 's. The substitution of these values x_1 , x_2 , y_1 , and y_2 in equation (3) furnishes two equations between constants, in which only α , and h are unknown. To eliminate α , for $\frac{1}{\cos^2 \alpha}$ we write $1 + \tan^2 \alpha$, and taking $x_2 = 2x_1$ for convenience, we finally obtain

$$h = \frac{1}{8} \cdot \frac{x_2^2 + (4y_1 - y_2)^2}{y_2 - 2y_1}, \text{ and } \therefore v_m = \sqrt{\frac{g[x_2^2 + (4y_1 - y_2)^2]}{4(y_2 - 2y_1)}},$$

in which y_1 and y_2 are the vertical distances of the two points

chosen *below* the orifice; that is, we have already made them negative in eq. (3) of page 84. The h of the preceding equation simply denotes $v_m^2 \div 2g$, and must not be confused with that of the last two figures. For accuracy the second point should be as far from the orifice along the jet as possible.

496. Orifice with Rounded Approach.*—Fig. 541 shows the general form and proportions of an orifice or mouth-piece in the use of which contraction does not take place beyond the edges, the inner surface being one “of revolution,” and so shaped that the liquid filaments are parallel on passing the outer edge m ; hence the pressure-head at m . is $= b$ ($= 34$ ft. for water and 30 inches for mercury) in Bernoulli’s Theorem, if efflux takes place *into the air*. We have also the sectional area $F_m = F$ = that of final edge of orifice, i.e., the coefficient of contraction, or C , = unity = 1.00, so that the discharge per time-unit has a volume

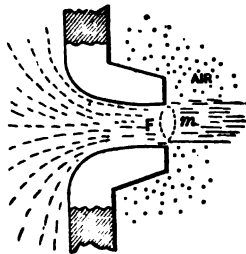

$$Q = F_m v_m = F v_m.$$

The tank being large, as in Fig. 540, Bernoulli’s Theorem applied to m and n will give, as before,

$$v_m = \sqrt{2gh}$$

as a theoretical result, while practically we write

$$v_m = \phi \sqrt{2gh}, \quad \dots \dots \dots (1)$$

and

$$Q = F\phi \sqrt{2gh}. \quad \dots \dots \dots (2)$$

As an average ϕ is found to differ little from 0.97 with this orifice, the same value as for an orifice in thin plate (§ 495).

497. Problems in Efflux Solved by Applying Bernoulli’s Theorem.—In the two preceding paragraphs the pressure-heads at sections m and n were each $= p_a \div \gamma =$ height of

* Smooth conical nozzles for fire-steams give $\phi = .97$ with $h =$ press.-head + veloc.-head at base of play-pipe; see p. 883.

the liquid barometer = b ; but in the following problems this will not be the case necessarily. However, efflux is to take place through a simple orifice in the side of a large reservoir, whose upper surface (n) is very large, so that v_n may be put = zero.

Problem I.—Fig. 542. What is the velocity of efflux, v_m , at the orifice m (i.e., at the contracted section, if it is an orifice in thin plate) of a jet of water from a steam-boiler, if the free surface at n is at a height = h above m , and the pressure of the steam over the water is p_n , the discharge taking place into the air?

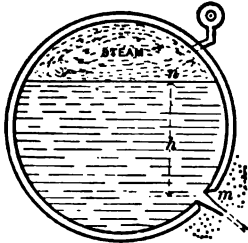

FIG. 542.

Applying Bernoulli's Theorem to section m at the orifice [where the pressure-head is b and velocity-head $v_m^2 \div 2g$ (unknown)] and to section n at water-surface (where velocity-head = 0 and pressure-head = $p_n \div \gamma$), we have, taking m as a datum for potential heads so that $z_m = 0$ and $z_n = h$,

$$\frac{v_m^2}{2g} + b + 0 = 0 + \frac{p_n}{\gamma} + h$$

$$\therefore v_m = \sqrt{2g \left[\frac{p_n}{\gamma} - b + h \right]} \dots \dots (1)$$

EXAMPLE.—Let the steam-gauge read 40 lbs. (and hence $p_n = 54.7$ lbs. per sq. inch) and $h = 2$ ft. 4 in.; required v_m .

Also if $F = \frac{1}{4}$ sq. in., in "thin plate," required the rate of discharge (volume). The temperature of saturated steam of the given tension must be 286° Fahr. [see foot of page 607]. The water is practically at the same temperature and hence of a heaviness, γ , of 57.7 lbs. per cubic ft. (p. 518).

From eq. (1) above, then, with ft. lb. and sec., noting that for this case $b = [(14.7 \div 144) \div 57.7]$ feet,

$$v_m = \sqrt{2 \times 32.2 \left[\frac{54.7 \times 144}{57.7} - \frac{14.7 \times 144}{57.7} + \frac{28}{12} \right]}$$

= 81.1 ft. per sec., theoretically; but practically

74

$$v_m = 0.97 \times 81.1 = 78.6 \text{ ft. per sec.};$$

so that the discharge begins at the rate of

$$Q = 0.64 Fv_m = 0.64 \times \frac{1}{4} \cdot \frac{1}{144} \times 78.6 = 0.174 \text{ cub. ft. p. sec.}$$

Problem II.—Fig. 543. With what velocity, v_m , will water flow into the condenser C of a steam-engine where the tension of the vapor is p_m , < one atmosphere, if h = the head of water, and the flow takes place through an orifice in thin plate? Taking position m in the contracted section where the filaments are parallel, and the pressure therefore equal to that of the surrounding vapor, viz., p_m , and position n in the (wide) free surface of the water in the tank, where (at surface) the pressure is one



FIG. 543.

atmosphere [and $\therefore \frac{p_n}{\gamma} = b = 34 \text{ ft.}$] and velocity practically zero; we have, applying Bernoulli's Theorem to n and m , taking m as a datum level for potential heads (so that $z_n = h$ and $z_m = 0$),

$$\frac{v_m^2}{2g} + \frac{p_m}{\gamma} + 0 = 0 + b + h,$$

\therefore

$$v_m = \sqrt{2g \left[h + b - \frac{p_m}{\gamma} \right]}, \dots \dots (1)$$

and $Q = F_m v_m, \dots \dots (2)$

as theoretical results. But practically we must write

$$v_m = 0.97 \sqrt{2g \left[h + b - \frac{p_m}{\gamma} \right]}, \dots \dots (3)$$

and $Q = F_m v_m = CF v_m, \dots \dots (4)$

in which F = area of orifice in thin plate, and C = coefficient of contraction = about 0.62 approximately [see § 495].

EXAMPLE.—If in the condenser there is a “vacuum” of $27\frac{1}{2}$ inches (meaning that the tension of the vapor would support $2\frac{1}{2}$ inches of mercury, in a barometer), so that

$$p_m = [2\frac{1}{2} \times 14.7] \text{ lbs. per sq. inch, and } h = 12 \text{ feet,}$$

while the orifice is $\frac{1}{2}$ inch in diameter; we have, using the ft., lb., and sec.,

$$v_m = 0.97 \sqrt{2 \times 32.2 \left[12 + 34 - \frac{2\frac{1}{2} \times 14.7 \times 144}{62.5} \right]}$$

$$= 51.1 \text{ ft. per sec.}$$

(We might also have written, for brevity,

$$\frac{p_m}{\gamma} = [2\frac{1}{2} : 30] \times 34 = 2.833,$$

since the pressure-head for one atmos. = 34 feet, for water. Hence, for a circular orifice in thin plate, we have the volume discharged per unit of time,

$$Q = CFv = 0.62 \times \frac{\pi}{4} \left(\frac{1}{2}\right)^2 \times 51.1 = 0.0431 \text{ cub. ft. per sec.}$$

497a. Efflux through an Orifice in Terms of the Internal and External Pressures.—Fig. 544. Let efflux take place through a small orifice from the plane side of a large tank, in which at the level of the orifice the *hydrostatic pressure* was = p' before the opening of the orifice, that of the medium surrounding the jet being = p'' . When a steady flow is established, after opening the orifice, the pressure in the water on a level with the orifice will not be materially changed, *except in the immediate neighborhood of the orifice* [see § 495]; hence, applying Bernoulli's Theorem to m in the jet, where the filaments are parallel, and a point n , in the body of the liquid and at the same level as m , and where the particles

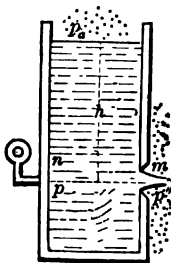

FIG. 544.

are practically at rest [i.e., $v_n = 0$] (hence not too near the

orifice), we shall have, cancelling out the potential heads which are equal,

$$\frac{v_m^2}{2g} + \frac{p''}{\gamma} = \frac{0^2}{2g} + \frac{p'}{\gamma},$$

$$\therefore v_m = 0.97\sqrt{2g\left[\frac{p' - p''}{\gamma}\right]}. \dots (1)$$

(In Fig. 544 p' would be equal to $p_a + h\gamma$.) Eq. (1) is conveniently applied to the jet produced by a *force-pump*, supposing, for simplicity, the orifice to be *in the head of the pump-cylinder*, as shown in Fig. 545. Let the thrust (force) exerted along the piston-rod be = P , and the area of the piston be = F' . Then the intensity of internal pressure produced in the chamber AB (when the piston moves uniformly) is

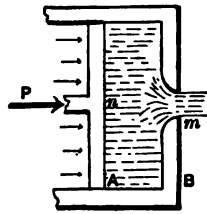

FIG. 545.

$$p' = \frac{P + F'p_a}{F'}$$

while the external pressure in the air around the jet is simply p_a (one atmos.).

$$\therefore v_m = 0.97\sqrt{2g \cdot \frac{P}{F'\gamma}}. \dots (1')$$

(N.B. Of course, at points near the orifice the internal pressure is $< p'$; read § 495.)

EXAMPLE.—Let the force, or thrust, P , [due to steam-pressure on a piston not shown in figure,] be 2000 lbs., and the diameter of pump-cylinder be $d = 9$ inches, the liquid being *salt water* (so that $\gamma = 64$ lbs. per cubic foot).

Then

$$F' = \frac{1}{4}\pi\left(\frac{9}{12}\right)^2 = 0.442 \text{ sq. ft.,}$$

and [ft., lb., sec.]

$$v_m = 0.97 \sqrt{2 \times 32.2 \times \frac{2000}{0.442 \times 64}} = 65.4 \text{ ft. per sec.}$$

If the orifice is well rounded, with a diameter of one inch, the volume discharged per second is

$$Q = F_m v_m = F v_m = \frac{\pi \left(\frac{1}{12}\right)^2}{4} \times 65.4 = 0.353 \text{ cub. ft. per sec.}$$

To maintain steadily this rate of discharge, the piston must move at the rate [veloc. = v'] of

$$v' = Q \div F' = .353 \div \left[\frac{\pi \left(\frac{9}{12}\right)^2}{4} \right] = 0.800 \text{ ft. per sec.,}$$

and the force P must exert a *power* (§ 130) of

$$\begin{aligned} L &= P v' = 2000 \times 0.800 = 1600 \text{ ft. lbs. per sec.} \\ &= \text{about 3 horse-power (or 3 H. P.).} \end{aligned}$$

If the water must be forced from the cylinder through a pipe or hose before passing out of a nozzle into the air, the velocity of efflux will be smaller, on account of "*fluid friction*" in the hose, for the same P ; such a problem will be treated later [§ 513]. Of course, in a pumping-engine, by the use of several pump-cylinders, and of air-chambers, a practically steady flow is kept up, notwithstanding the fact that the motion of each piston is not uniform, and must be reversed at the end of each stroke.

498. Influence of Density on the Velocity of Efflux in the Last Problem.—From the equation

$$v_m = \sqrt{2g \frac{p' - p''}{\gamma}}$$

of the preceding paragraph, where p'' is the external pressure around the jet, and p' the internal pressure at the same level as the orifice but well back of it, *where the liquid is sensibly*

at rest, we notice that for the same difference of pressure [$p' - p''$] the velocity of efflux is inversely proportional to the square root of the heaviness of the liquid. Hence, for the same ($p' - p''$), mercury would flow out of the orifice with a velocity only 0.272 of that of water; for

$$\sqrt{\frac{62.5}{848}} = \sqrt{\frac{1}{13.5}} = \frac{272}{1000}.$$

Again, assuming that the equation holds good for the flow of gases (as it does approximately when p' does not greatly exceed p'' ; e.g., by 6 or 8 per cent), the velocity of efflux of atmospheric air, when at a heaviness of 0.807 lbs. per cub. foot, would be

$$\sqrt{\frac{62.5}{.0807}} = \sqrt{775.3} = 27.8$$

times as great as for water, with the same $p' - p''$. (See § 548, etc.)

499. Efflux under Water. Simple Orifice.—Fig. 546. Let h_1 and h_2 be the depths of the (small) orifice below the levels of the “head” and “tail” waters respectively. Then, using the formula of § 457, we have for the pressure at n (at same level as m , the jet)

$$p' = (h_1 + b)\gamma,$$

and for the external pressure, around the jet at m ,

$$p'' = (h_2 + b)\gamma;$$

whence, theoretically,

$$v_m = \sqrt{2g \frac{p' - p''}{\gamma}} = \sqrt{2g(h_1 - h_2)} = \sqrt{2gh}, \quad (1)$$

where h = difference of level between the surfaces of the two bodies of water.

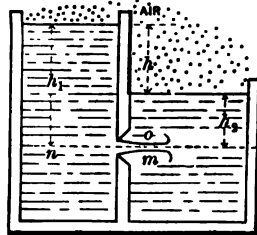

FIG. 546.

Practically, $v_m = \phi \sqrt{2gh}$; (2)

but the value of ϕ for efflux under water is somewhat uncertain; as also that of C , the coefficient of contraction. Weisbach says that $\mu = \phi C$, is $\frac{1}{8}$ part less than for efflux into the air; others, that there is no difference (Trautwine). See also p. 389 of vol. 6, Jour. of Engin. Associations, where it is stated that with a circular mouth-piece of 0.37 in. diam., and of "nearly the form of the *vena contracta*," μ was found to be .952 for discharge into the air, and .945 for submerged discharge.

500. Efflux from a Small Orifice in a Vessel in Motion.

CASE I. *When the motion is a vertical translation and uniformly accelerated.*—Fig. 547. Suppose the vessel to move up

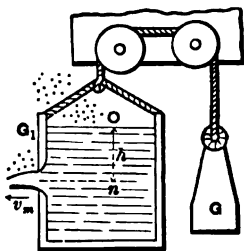

FIG. 547.

ward with a constant acceleration \bar{p} . (See § 49a.) Taking m and n as in the two preceding paragraphs, we know that $p_m = p'' =$ external pressure = one at-
mos. = p_a (and $\therefore \frac{p_m}{\gamma} = b$). As to the

internal pressure at n (same level as m , but well back of orifice), p_n , this is not equal to $(b + h)\gamma$, because of the accel-

erated motion, but we may determine it by considering free the vertical column or prism On of liquid, of cross-section = dF , the vertical forces acting on which are $p_a dF$, downward at O , $p_n dF$ upward at n , and its weight, downward, $hdF\gamma$. All other pressures are horizontal. For a vertical upward acceleration = \bar{p} , the algebraic sum of the vertical components of all the forces must = *mass* \times *vert. accel.*,

i.e.,
$$dF(p_n - p_a - h\gamma) = \frac{h\gamma dF}{g} \cdot \bar{p};$$

whence

$$p_n = p_a + h\gamma \left[1 + \frac{\bar{p}}{g} \right]. \dots \dots (1)$$

Putting p_n and p_a equal to the p' and p'' , respectively, of the equation, we have

$$v_m = \sqrt{2g \left[\frac{p_n - p_m}{\gamma} \right]}$$

of § 497,

$$v_m = \sqrt{2(g + \bar{p})h}. \dots \dots \dots (2)$$

It must be remembered that v_m is the velocity of the jet *relatively to the orifice*, which is itself in motion with a variable velocity. The absolute velocity w_m of the particles of the jet is found by the construction in § 83, being represented graphically by the diagonal of a parallelogram one of whose sides is v_m , and the other the velocity c with which the orifice itself is moving at the instant, as part of the vessel. The jet may make any angle with the side of the vessel.

On account of the flow the internal pressures of the water against the vessel are no longer balanced horizontally, and the latter will swing out of the vertical unless properly constrained.

If $\bar{p} = g = \text{acc. of gravity}$, $v_m = \sqrt{2} \sqrt{2gh}$. If \bar{p} is *negative* and $= g$, $v_m = 0$; i.e., there is no flow, but both the vessel and its contents fall freely, without mutual action.

CASE II. *When the liquid and the vessel both have a uniform rotary motion about a vertical axis with an angular velocity = ω (§ 110). Orifice small, so that we may consider the liquid inside (except near the orifice) to be in relative equilibrium. Suppose the jet horizontal at m , Fig. 548. and the radial distance of the orifice from the axis to be = x . The external pressure $p_m = p_a$, and the internal [see § 428, eqs. (3) and (4)] is*

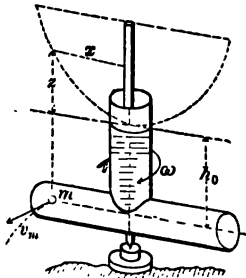

FIG. 548.

$$p_n = p_a + (h_0 + z)\gamma = p_a + h_0\gamma + \frac{\omega^2 x^2}{2g} \gamma;$$

hence the velocity of the jet, relatively to the orifice, is (from § 497, since p_n and p_m correspond to the p' and p'' of that article),

$$v_m = \sqrt{2g \left(\frac{p_n - p_m}{\gamma} \right)} = \sqrt{2gh_0 + (\omega x)^2},$$

i.e.,
$$v_m = \sqrt{2gh_0 + w^2}; \dots \dots \dots (3)$$

in which $w = \omega x$, = the (constant) linear velocity of the orifice in its circular path. The *absolute velocity w_m of the particles in the jet* close to the orifice is the diagonal formed on w and v_m (§ 83). Hence by properly placing the orifice in the casing, w_m may be made small or large, and thus the kinetic energy carried away in the effluent water be regulated, within certain limits. Equation (3) will be utilized subsequently in the theory of Barker's Mill.

EXAMPLE.—Let the casing make 100 revol. per min. (whence $\omega = [2\pi 100 \div 60]$ radians per sec.), $h_0 = 12$ feet, and $x = 2$ ft.; then (ft., lb., sec.)

$$v_m = \sqrt{2 \times 32.2 \times 12 + \left(\frac{2\pi 100 \times 2}{60}\right)^2} = 34.8 \text{ ft. per sec.}$$

(while, if the casing is not revolving, $v_m = \sqrt{2gh_0}$, = only 27.8 ft. per sec.).

If the jet is now directed horizontally and backward, and also tangentially to the circular path of the centre of the orifice, its *absolute velocity* (i.e., relatively to the earth) is

$$w_m = v_m - \omega x = 34.8 - 20.9 = 13.9 \text{ ft. per sec.,}$$

and is also horizontal and backwards. If the volume of flow is $Q = 0.25$ cub. feet per sec., the *kinetic energy carried away with the water per second* (§ 133) is

$$= \frac{1}{2} M w_m^2 = \frac{Q\gamma}{g} \cdot \frac{w_m^2}{2} = \frac{\frac{1}{2} \times 62.5}{32.2} \frac{(13.9)^2}{2} = 46.8$$

ft. lbs. per second = 0.085 horse-power.

501. Theoretical Efflux through Rectangular Orifices of Considerable Vertical Depth, in a Vertical Plate.—If the orifice is so large vertically that the velocities of the different filaments in a vertical plane of the stream are theoretically different, having different "heads of water," we proceed as follows, taking into account, also, *the velocity of approach, c* , or mean velocity

(if any appreciable), of the water in the channel approaching the orifice.

Fig. 549 gives a section of the side of the tank and orifice. Let b = width of the rectangle, the sills of the latter being horizontal, and $a = h_1 - h_2$, its height. Disregarding contraction for the present, the theoretical volume of discharge per unit of time is equal to the sum of the volumes like $v_m dF$ ($= v_m b dx$), in which v_m = the velocity of any filament, as m , in the jet, and $b dx$ = cross-section of the small prism which passes through any horizontal strip of the area of orifice, in a unit of time, its altitude being v_m . For each strip there is a different x or "head of water," and hence a different velocity. Now the *theoretical* discharge (volume) per unit of time is

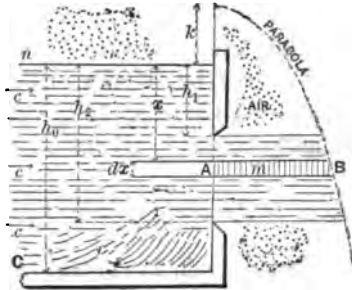

FIG. 549.

$$Q = \text{sum of the volumes of the elem. prisms} = \int_{x=h_1}^{x=h_2} v_m dF;$$

i.e.,
$$Q = b \int_{h_1}^{h_2} v_m dx. \quad \dots \dots \dots (1)$$

But from Bernoulli's Theorem, if $k = c^2 \div 2g$ = the velocity-head at n , the surface of the channel of approach nC , b being the pressure-head of n , and x its potential head referred to m as datum (N.B. This $b = 34$ ft. for water, and must not be confused with the width b of orifice), we have [see § 492, eq. (7)]

$$\frac{v_m^2}{2g} + b + 0 = \frac{c^2}{2g} \text{ (or } k) + b + x;$$

$$\therefore v_m = \sqrt{2g} \sqrt{x + k}; \quad \dots \dots \dots (2)'$$

and since $dx = d(x + k)$, k being a constant, we have, from (1)' and (2)',

Theoret.
$$Q = b \sqrt{2g} \int_{h_1+k}^{h_2+k} (x+k)^{\frac{1}{2}} d(x+k),$$

or

$$\textit{Theoret. } Q = \frac{2}{3} b \sqrt{2g} [(h_1 + k)^{\frac{3}{2}} - (h_1 + k)^{\frac{3}{2}}]. \quad (1)$$

(b now denotes the width of orifice.) If c is small, the channel of approach being large, we have

$$\textit{Theoret. } Q = \frac{2}{3} b \sqrt{2g} (h_2^{\frac{3}{2}} - h_1^{\frac{3}{2}}) \quad \dots \quad (2)$$

(c being = $Q \div$ area of section of nC).

If $h_1 = 0$, i.e., if the orifice becomes a *notch in the side*, or an *overflow* [see Fig. 550, which shows the contraction which actually occurs in all these cases], we have for an *overflow*

$$\textit{Theoret. } Q = \frac{2}{3} b \sqrt{2g} [(h_2 + k)^{\frac{3}{2}} - k^{\frac{3}{2}}]. \quad \dots \quad (3)$$

NOTE.—Both in (1) and (2) h_1 and h_2 are the vertical depths of the respective sills of the orifice from the *surface of the water three or four feet back of the plane of the orifice*, where the surface is comparatively level. This must be specially attended to in deriving the actual discharge from the

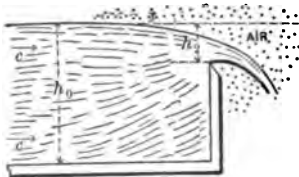

FIG. 550.

theoretical (see § 503).

If Q were the unknown quantity in eqs. (1) and (3) it would be necessary to proceed by successive assumptions and approximations, since Q is really involved in k ; for

$$k = \frac{c^2}{2g} \quad \text{and} \quad F_0 c = Q$$

(where F_0 is the sectional area of the channel of approach nC).

With $k = 0$ (or c very small, i.e., F_0 very large), eq. (3) reduces (for an *overflow*) to

$$\textit{Theoret. } Q = \frac{2}{3} b h_2 \sqrt{2g h_2}, \quad \dots \quad (3\frac{1}{2})$$

or $\frac{2}{3}$ as much as if all parts of the orifice had the same head of water = h_2 (as for instance if the orifice were in the horizontal bottom of a tank in which the water was h_2 deep, the orifice having a width = b and length = h_2).

502. **Theoretical Efflux through a Triangular Orifice in a Thin Vertical Plate or Wall. Base Horizontal.**—Fig. 551. Let the channel of approach be so large that the velocity of approach may be neglected. h_1 and h_2 = depths of sill and vertex, which is downward. The analysis differs from that of the preceding article only in having $k = 0$ and the length u , of a horizontal strip of the orifice, variable; b being the length of the base of the triangle. From similar triangles we have

$$\frac{u}{b} = \frac{h_2 - x}{h_2 - h_1}; \text{ i.e., } u = \frac{b}{h_2 - h_1}(h_2 - x).$$

$$\therefore \textit{Theoret. } Q = \int v_m dF = \int v_m u dx = \frac{b}{h_2 - h_1} \int_{h_1}^{h_2} v_m (h_2 - x) dx;$$

and finally, substituting from eq. (2)' of § 501, with $k = 0$,

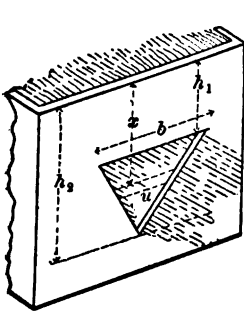

FIG. 551.

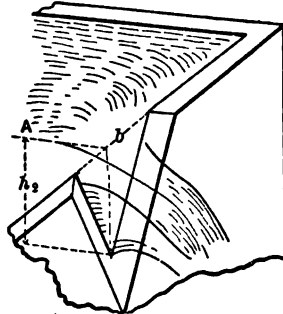

FIG. 552.

$$\begin{aligned} \textit{Theoret. } Q &= \frac{b \sqrt{2g}}{h_2 - h_1} \int_{h_1}^{h_2} (h_2 - x) x^{3/2} dx \\ &= \frac{2}{15} \frac{b \sqrt{2g}}{h_2 - h_1} [2h_2^{5/2} - 5h_2 h_1^{3/2} + 3h_1^{5/2}]. \dots (4) \end{aligned}$$

For a *triangular notch* as in Fig. 552, this reduces to

$$\textit{Theoret. } Q = \frac{4}{15} b h_2 \sqrt{2g h_2} = \frac{8}{15} \frac{b h_2}{2} \sqrt{2g h_2}; \dots (5)$$

i.e., $\frac{8}{15}$ of the volume that would be discharged per unit of

time if the triangular orifice with base b and altitude h_1 were cut in the horizontal bottom of a tank under a head of h_1 . The measurements of h_1 and b are made with reference to the level surface back of the orifice (see figure); for the water-surface in the plane of the orifice is curved below the level surface in the tank.

Prof. Thomson has found by experiment that with $b = 2h_1$, the actual discharge = theoret. disch. $\times 0.595$; and with $b = 4h_1$, actual = theoret. disch. $\times 0.620$.

503. Actual Discharge through Sharp-edged Rectangular Orifices (sills horizontal) in the vertical side of a tank or reservoir.

CASE I. Complete and Perfect Contraction.—The actual volume of water discharged per unit of time is much less than the theoretical values derived in § 501, chiefly on account of contraction. By *complete contraction* we mean that no edge of the orifice is flush with the side or bottom of the reservoir; and by *perfect contraction*, that the channel of approach, to whose surface the heads h_1 and h_2 are measured, is so large that the contraction is practically the same if the channel were of infinite extent sideways and downward

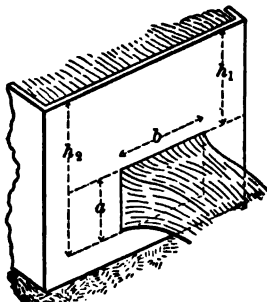

FIG. 553.

from the orifice.

For this case (h_2 not zero) it is found most convenient to use the following practical formula (b = width):

$$\text{Actual } Q = \mu_s ab \sqrt{2g \left[h_1 + \frac{a}{2} \right]}, \quad \dots (6)$$

in which (see Fig. 553) a = the height of orifice, h_1 = the vertical depth of the upper edge of the orifice below the level of the reservoir surface, *measured a few feet back of the plane of the orifice*, and μ_s is a *coefficient of efflux* (an abstract number), dependent on experiment.

With $\mu_s = 0.62$ approximate results (within 3 or 4 per cent) may be obtained from eq. (6) with openings not more than

18 inches, or less than 1 inch, high; and not less than 1 inch wide; with heads $(h_1 + \frac{a}{2})$ from 1 ft. to 20 or 30 feet.

EXAMPLE.—What is the actual discharge (volume) per minute through the orifice in Fig. 553, 14 inches wide and 1 foot high, the upper sill being 8 ft. 6 in. below the surface of still water? Use eq. (6) with the ft., lb., and sec. as units, and $\mu_0 = 0.62$.

Solution:

$$Q = 0.62 \times 1 \times 1\frac{1}{2} \times \sqrt{2 \times 32.2 [8\frac{1}{2} + \frac{1}{2}]} = 17.41 \text{ cub. ft. per sec.}$$

while the flow of weight is

$$G = Q\gamma = 17.41 \times 62.5 = 1088 \text{ lbs. per second.}$$

Poncelet and Lesbros' Experiments.—For comparatively accurate results, values of μ_0 , taken from the following table (computed from the careful experiments of Poncelet and Lesbros) may be used for the sizes there given, and, where practicable, for other sizes by interpolation. To use the table, the values of h_1 , a , and b must be reduced to metres, which can be done by the reduction-table below; but in substituting in eq. (6), if the metre-kilogram-second system of units be used g must be put = 9.81 metres per square second (see § 51), and Q will be obtained in cubic metres per second.

Since μ_0 is an abstract number, once obtained as indicated above, it does not necessitate any particular system of units in making substitutions in eq. (6). The ft., lb., and sec. will be used in subsequent examples.

TABLE FOR REDUCING FEET AND INCHES TO METRES.

1 foot = 0.30479 metre.	1 inch = 0.0253 metre.
2 feet = 0.60959 "	2 inches = 0.0507 "
3 " = 0.91438 "	3 " = 0.0761 "
4 " = 1.21918 metres.	4 " = 0.1015 "
5 " = 1.52397 "	5 " = 0.1268 "
6 " = 1.82877 "	6 " = 0.1522 "
7 " = 2.13356 "	7 " = 0.1776 "
8 " = 2.43836 "	8 " = 0.2030 "
9 " = 2.74315 "	9 " = 0.2283 "
10 " = 3.04794 "	10 " = 0.2536 "
	11 " = 0.2790 "

TABLE, FROM PONCELET AND LAPLACE.

VALUES OF μ_0 , FOR EQ. (6), FOR RECTANGULAR ORIFICES IN THIN PLATE.

(Complete and perfect contraction.)

Value of h_1 , Fig. 553 (in metres).	$b = .30^m$ $a = .30^m$	$b = .30^m$ $a = .10^m$	$b = .30^m$ $a = .06^m$	$b = .30^m$ $a = .08^m$	$b = .30^m$ $a = .02^m$	$b = .30^m$ $a = .01^m$	$b = .60^m$ $a = .30^m$	$b = .60^m$ $a = .09^m$
	μ_0	μ_0	μ_0	μ_0	μ_0	μ_0	μ_0	μ_0
0.005						0.705		
.010			0.607	0.680	0.660	.701		0.644
.015		0.598	.612	.682	.660	.697		.644
.020	0.579	.598	.615	.684	.659	.694		.643
.030	.578	.600	.620	.688	.659	.688	0.598	.642
.040	.582	.603	.623	.640	.658	.688	.595	.642
.050	.585	.605	.625	.640	.658	.679	.597	.641
.060	.587	.607	.627	.640	.657	.676	.599	.641
.070	.588	.609	.628	.639	.656	.673	.600	.640
.080	.589	.610	.629	.638	.656	.670	.601	.640
.090	.591	.610	.629	.637	.655	.668	.601	.639
.100	.592	.611	.630	.637	.654	.666	.602	.639
.120	.593	.612	.630	.636	.653	.663	.603	.638
.140	.595	.613	.630	.635	.651	.660	.603	.637
.160	.596	.614	.631	.634	.650	.658	.604	.637
.180	.597	.615	.630	.634	.649	.657	.605	.636
.200	.598	.615	.630	.633	.648	.655	.605	.635
.250	.599	.616	.630	.632	.646	.653	.606	.634
.300	.600	.616	.629	.632	.644	.650	.607	.633
.400	.602	.617	.628	.631	.642	.647	.607	.631
.500	.603	.617	.628	.630	.640	.644	.607	.630
.600	.604	.617	.627	.630	.638	.642	.607	.629
.700	.604	.616	.627	.629	.637	.640	.607	.628
.800	.605	.616	.627	.629	.636	.637	.606	.628
.900	.605	.615	.626	.628	.634	.635	.606	.627
1.000	.605	.615	.626	.628	.633	.632	.605	.626
1.100	.604	.614	.625	.627	.631	.629	.604	.626
1.200	.604	.614	.624	.626	.628	.626	.604	.625
1.300	.603	.613	.623	.624	.625	.622	.603	.624
1.400	.603	.612	.621	.622	.622	.618	.603	.624
1.500	.602	.611	.620	.620	.619	.615	.602	.623
1.600	.602	.611	.618	.618	.617	.613	.602	.623
1.700	.602	.610	.617	.616	.615	.612	.602	.622
1.800	.601	.609	.615	.615	.614	.612	.602	.621
1.900	.601	.608	.614	.613	.612	.611	.602	.621
2.000	.601	.607	.613	.612	.612	.611	.602	.620
3.000	.601	.603	.606	.608	.610	.609	.601	.615

EXAMPLE. — With $h_1 = 4$ in. [= 0.10 met.], $a = 8$ in. [= 0.20 met.], $b = 1$ ft. 8 in. [= 0.51 met.], required the (actual) volume discharged per second. See Fig. 553.

From the following table,
 for $h_1 = 0.10^m$, $b = 0.60^m$ and $a = 0.20^m$, we find $\mu_0 = .602$
 “ $h_1 = 0.10^m$, $b = 0.20^m$ “ $a = 0.20^m$, “ $\mu_0 = .592$
diff. = .010

Hence, by interpolation,

for $h_1 = 0.10^m$, $b = 0.51^m$, and $a = 0.20^m$, we have

$$\mu_0 = 0.602 - \frac{0}{.10} [0.602 - 0.592] = 0.600.$$

Hence [ft., lb., sec.], remembering that μ_0 is an abstract number, from eq. (6),

$$Q = 0.600 \times \frac{8}{15} \times \frac{11}{12} \sqrt{2} \times 32.2 \left(\frac{4}{15} + \frac{1}{3} \cdot \frac{8}{15} \right) = 4.36$$

cub. ft. per second.

CASE II. *Incomplete Contraction.*—This name is given to the cases, like those shown in Fig. 554, where one or more sides of the orifice have an interior border flush with the sides or bottom of the (square-cornered) tank.

Not only is the general direction of the stream altered, but the discharge is *greater*, on account of the larger size of the contracted section, since contraction is prevented on those sides which have a border. It is assumed that the contraction which *does* occur (on the other edges) is *perfect*; i.e., the cross-section of the tank is large compared with the orifice. According to the experiments of Bidone and Weisbach with Poncelet's orifices (i.e., orifices in thin plate mentioned in the preceding table), the actual volume discharged per unit of time is

$$Q = \mu ab \sqrt{2g \left(h_1 + \frac{a}{2} \right)}. \quad (7)$$

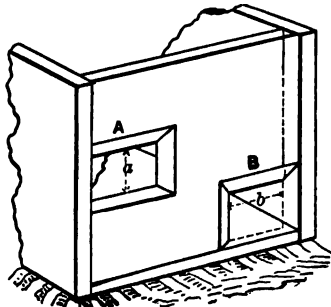

FIG. 554.

(differing from eq. (6) only in the coefficient of efflux μ), in which the abstract number μ is found thus: Determine a coefficient of efflux μ_0 as if eq. (6) were to be used in Case I; i.e., as if contraction were complete and perfect; then write

$$\mu = \mu_0 [1 + 0.155 n] \dots \dots \dots (7)'$$

where n = the ratio of the length of periphery of the orifice with a border to the whole periphery.

E.g., if the lower sill, only, has a border,

$$n = b \div [2(a + b)];$$

while if the lower sill and both sides have a border,

$$n = (2a + b) \div [2(a + b)].$$

EXAMPLE.—If $h_1 = 8$ ft. (= 2.43^m), $b = 2$ ft. (= 0.60^m), $a = 4$ in. (= 0.10^m), and one side is even with the side of the tank, and the lower sill even with the bottom, required the volume discharged per second. (Sharp-edged orifice, in vertical plane, etc.)

Here for complete and perfect contraction we have, from Poncelet's tables (Case I), $\mu_0 = 0.608$. Now $n = \frac{1}{2}$; hence, from eq. (7)',

$$\mu = 0.608 [1 + 0.155 \times \frac{1}{2}] = 0.6551;$$

hence, eq. (7),

$$Q = 0.655 \times 2 \times \frac{1}{12} \sqrt{2 \times 32.2 (8 + \frac{1}{2} \cdot \frac{2}{12})}$$

$$= 10.23 \text{ cub. ft. per sec.}$$

CASE III. Imperfect Contraction.—If there is a submerged channel of approach, symmetrically placed as regards the orifice, and of an area (cross-section), = G , not much larger than that, = F , of the orifice (see Fig. 555), the contraction is less than in Case I, and is called *imperfect contraction*.

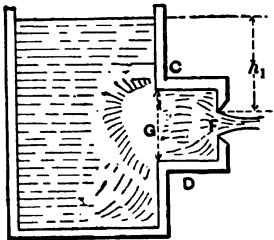

FIG. 555.

Upon his experiments with Poncelet's orifices, with imperfect contraction, Weisbach

bases the following formula for the discharge (volume) per unit of time, viz.,

$$Q = \mu ab \sqrt{2g (h_1 + \frac{a}{2})} \dots \dots \dots (8)$$

(see Fig. 553 for notation), with the understanding that the coefficient

$$\mu = \mu_0(1 + \beta), \quad \dots \dots \dots (8')$$

where μ_0 is the coefficient obtained from the tables of Case I (as if the contraction were perfect and complete), and β an abstract number depending on the ratio $F : G = m$, as follows:

$$\beta = 0.0760 [9^m - 1.00]. \dots \dots \dots (8'')$$

To shorten computation Weisbach gives the following table for β :

EXAMPLE.—Let $h_1 = 4' 9\frac{1}{2}'' (= 1.46$ met.) the dimensions of the orifice being—

width = $b = 8$ in. (= 0.20^m);
height = $a = 5$ in. (= 0.126^m);

while the channel of approach (CD , Fig. 555) is one foot square. From Case I, we have, for the given dimensions and head,

TABLE A.

m.	β .	m.	β .
.05	.009	.55	.178
.10	.019	.60	.208
.15	.030	.65	.241
.20	.042	.70	.278
.25	.056	.75	.319
.30	.071	.80	.365
.35	.088	.85	.416
.40	.107	.90	.473
.45	.128	.95	.537
.50	.152	1.00	.608

$$\mu_0 = 0.610;$$

$$\frac{F}{G} = \frac{40 \text{ sq. in.}}{144 \text{ sq. in.}} = 0.27.$$

We find [Table A]

$$\beta = 0.062;$$

and hence $\mu = \mu_0 (1.062)$, from eq. (8)'. Therefore, from eq. (8), with ft., lb., and sec.,

$$Q = 0.610 \times 1.062 \times \frac{5}{12} \cdot \frac{8}{12} \sqrt{2 \times 32.2 \times 5}$$

$$= 3.22 \text{ cub. ft. per sec.}$$

CASE IV. *Head measured in Moving Water.*—See Fig. 556. If the head h_1 , of the upper sill, cannot be measured to the level of still water, but must be taken to the surface of a channel of approach, where the velocity of approach is quite

appreciable, not only is the contraction imperfect, but strictly we should use eq. (1) of § 501, in which the velocity of approach is considered. Let F = area of orifice, and G that of the cross-section of the channel of approach; then the velocity of approach is $c = Q \div G$, and h (of above eq.) = $c^2 \div 2g = Q^2 \div 2gG^2$; but Q itself being unknown, a substitution of h in terms of Q in eq. (1), § 501, leads to an equation of high degree with respect to Q .

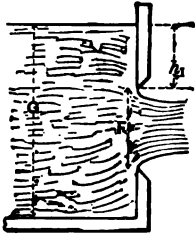

FIG. 556.

Practically, therefore, it is better to write

$$Q = \mu ab \sqrt{2g \left(h_1 + \frac{a}{2} \right)}, \dots \dots (9)$$

and determine μ by experiment for different values of the ratio $F \div G$. Accordingly, Weisbach found, for Poncelet's orifices, that if μ_c is the coefficient for complete and perfect contraction from Case I, we have

$$\mu = \mu_c (1 + \beta'). \dots \dots (9')$$

β' being an abstract number, and being thus related to $F \div G$,

$$\beta' = 0.641 \left(\frac{F}{G} \right)^2 \dots \dots (9'')$$

h_1 was measured to the surface one metre back of the plane of the orifice, and $F : G$ did not exceed 0.50.

Weisbach gives the following table computed from eq. (9)'':

TABLE B.

$F \div G$.	β' .
0.05	.002
.10	.006
.15	.014
.20	.026
.25	.040
.30	.058
.35	.079
.40	.103
.45	.130
.50	.160

EXAMPLE.—A rectangular water-trough 4 ft. wide is dammed up with a vertical board in which is a rectangular orifice, as in Fig. 556, of width $b = 2$ ft. (= 0.60 met.), and height $a = 6$ in. (= 0.15 met.); and when the water-level behind the board has ceased rising (i.e., when the flow has become *steady*), we find that $h_1 = 2$ ft., and the depth behind in the trough to be 3 ft. Required Q .

Since $F : G = 1$ sq. ft. \div 12 sq. ft. = .0833, we find (Table B) $\beta' = 0.005$; and μ_c being = 0.612 from Poncelet's tables, Case I, we have finally, from eq. (9),

$$Q = 0.612(1.005) 2 \times \frac{1}{4} \sqrt{2 \times 32.2 \times 2.25} = 7.41 \text{ cub. ft. per second.}$$

504. Actual Discharge of Sharp-edged Overfalls (Overfall-weirs; or Rectangular Notches in a Thin Vertical Plate).

CASE I. *Complete and Perfect Contraction (the normal case)*, Fig. 557; i.e., no edge is flush with the side or bottom of the reservoir, whose sectional area is very large compared with that, bh_s , of the notch. By depth, h_s , of the notch, we are to understand the *depth of the sill below the surface a few feet back of the notch where it is level*. In the plane of the

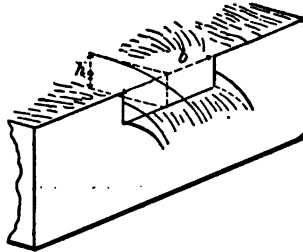

FIG. 557.

notch the vertical thickness of the stream is only from $\frac{1}{4}$ to $\frac{1}{10}$ of h_s . Putting, therefore, the velocity of approach = zero, and hence $k = 0$, in eq. (3) of § 501, we have for the

$$\text{Actual } Q = \mu_s \frac{2}{3} b h_s \sqrt{2gh_s}, \dots \dots (10)$$

(b = width of notch,) where μ_s is a *coefficient of efflux* to be determined by experiment.

Experiments with overfalls do not agree as well as might be desired. Those of Poncelet and Lesbros gave the results in Table C.

EXAMPLE 1.—With

$$h_s = 1 \text{ ft. 4 in. } (= .405^m),$$

$$b = 2 \text{ ft. } (= 0.60^m),$$

we have, from Table C, $\mu_s = .586$, and (ft., lb., sec.)

$$\therefore Q = .586 \times \frac{2}{3} \times 2 \times \frac{1}{4} \sqrt{2 \times 32.2 \times \frac{1}{4}} = 9.54 \text{ cub. ft. per sec.}$$

TABLE C.

For $b = 0.30^m$.		For $b = 0.60^m$.	
metres.		metres.	
h_s	μ_s	h_s	μ_s
.01	.688	.08	.618
.02	.620	.08	.618
.08	.618	.10	.609
.04	.610	.12	.605
.06	.601	.15	.600
.08	.595	.20	.592
.10	.592	.30	.586
.15	.589	.40	.586
.20	.585	.50	.586
.22	.577	.60	.585

For approx. results $\mu_s = .60$

EXAMPLE 2.—What width, b , must be given to a rectangular notch, for which $h_s = 10$ in. ($= 0.25^m$), that the discharge may be $Q = 6$ cub. feet per sec.?

Since b is unknown, we cannot use the table immediately, but take $\mu_0 = .600$ for a first approximation ; whence, eq. (10), (ft., lb., sec.,)

$$b = \frac{6}{0.6 \times \frac{2}{3} \times \frac{1}{12} \sqrt{2} \times 32.2 \times \frac{1}{12}} = 2.46 \text{ ft.}$$

Then, since this width does not much exceed 0.60 metre, we may take, in Table C, for $h_0 = 0.25$ met., $\mu_0 = .589$;

$$\therefore b = \frac{6}{.589 \times \frac{2}{3} \times \frac{1}{12} \sqrt{2} \times 32.2 \times \frac{1}{12}} = 2.50 \text{ ft.}$$

CASE II. *Incomplete Contraction* ; i.e., both ends are flush with the sides of the tank, these being \perp to the plane of the notch. According to Weisbach, we may write

$$Q = \frac{2}{3} \mu b h_0 \sqrt{2gh_0}, \dots \dots \dots (11)$$

in which $\mu = 1.041\mu_0$, μ_0 being obtained from Table C for the normal case, i.e., Case I. The section of channel of approach is large compared with that of the notch ; if not, see Case IV.

CASE III. *Imperfect Contraction* ; i.e., the velocity of approach is appreciable ; the sectional area G of the channel of approach not being much larger than that, $F = bh_0 =$ area of notch. Fig. 558. $b =$ width, and $h_0 =$ depth of notch (see Case I). Here, instead of using a formula involving

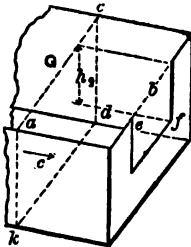

FIG. 558.

$$k = c^2 \div 2g = [Q \div G]^2 \div 2g$$

(see eq. (3), § 501), it is more convenient to put

$$Q = \frac{2}{3} \mu b h_0 \sqrt{2gh_0}, \dots \dots \dots (12)$$

as before, with

$$\mu = \mu_0 (1 + \beta), \dots \dots \dots (12)'$$

in which μ_0 is for the normal case [Case I] ; and β , according

to Weisbach's experiments, may be obtained from the empirical formula

$$\beta = 1.718 \left(\frac{F}{G}\right)^4 \dots \dots \dots (12)''$$

[Table D is computed from (12)'']

(The contraction is *complete* in this case; i.e., the ends are not flush with the sides of the tank.)

EXAMPLE.—If the water in the channel of approach has a vertical transverse section of $G = 9$ sq. feet, while the notch is 2 feet wide (i.e., $b = 2'$) and 1 foot deep ($h_s = 1'$ (to level of surface of water 3 or 4 ft. back of notch), we have, from Table C, with $b = .60$ met. and $h_s = 0.30$ met.,

TABLE D.

$\frac{F}{G}$	β .
0.05	.000
.10	.000
.15	.001
.20	.008
.25	.007
.30	.014
.35	.026
.40	.044
.45	.070
.50	.107

$$\mu_s = 0.586;$$

while from Table D, with $F : G = 0.222$ (or $\frac{1}{4}$),

$$\beta = .005;$$

hence (ft.-lb.-sec. system of units), from eq. (12),

$$Q = \frac{1}{4} \times 0.586 \times 1.005 \times 2 \times 1 \times \sqrt{64.4 \times 1.0}$$

$$= 6.30 \text{ cub. ft. per second.}$$

CASE IV. Fig. 559. *Imperfect and incomplete contraction together*; both end-contractions being "suppressed" (by making the ends flush with the sides of the reservoir, these sides being vertical and \perp to the plane of the notch), and the channel of approach not being very deep, i.e., having a sectional area G but little larger than that, F , of notch. $F = bh_s$, as before.

Again we write

$$Q = \frac{1}{4} \mu b h_s \sqrt{2gh_s}, \dots \dots \dots (13)$$

with μ computed from

$$\mu = \mu_s (1 + \beta), \dots \dots \dots (13)'$$

μ_s being obtained from Table C; while

$$\beta = 0.041 + 0.3693 \left(\frac{F}{G}\right)^2, \dots (13)''$$

an empirical formula based by Weisbach on his own experiments.* To save computation, β may be found from Table E, founded on eq. (13)''.

TABLE E.

$\frac{F}{G} =$.00	.05	.10	.15	.20	.25	.30	.35	.40	.45	.50
$\beta =$.041	.042	.045	.049	.056	.064	.074	.086	.100	.116	.133

EXAMPLE.—Fig. 559. With

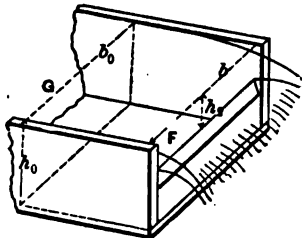

FIG. 559.

$b = 2 \text{ ft. (=0.60 met.)}$

and

$h_1 = 1 \text{ ft. (= 0.30 met.)}$,

we have, from Table C, $\mu_s = 0.586$. But, the ends being flush with the sides of the reservoir or channel, and G being = 6 sq. ft. (see figure),

which is not excessively large compared with $F = bh_1 = 2$ sq. ft., we have, from Table E, with $F : G = 0.333$,

$\beta = .081 ;$

and hence [eq. (13) and (13)'], μ_s being .586 as in last example,

$$Q = \frac{2}{3} \times 0.586 \times (1 + .081) \times 2 \times 1 \times \sqrt{64.4 \times 1.0} = 6.78 \text{ cub. ft. per sec.}$$

505. Francis' Formula for Overfalls (i.e., rectangular notches).—From extensive experiments at Lowell, Mass., in 1851, with rectangular overfall-weirs, Mr. J. B. Francis deduced the following formula for the volume, Q , of flow per second over such weirs 10 feet in width, and with h_1 varying from 0.6 to 1.6 feet (from sill of notch to level surface of water a few feet back):

* Weisbach's results in this case differ considerably from those of Bazin; see p. 688.

$$Q = \frac{2}{3} \times 0.622h_1(b - \frac{1}{10}nh_1) \sqrt{2gh_1}, \quad \dots (14)$$

in which b = width.

This provides for incomplete contraction, as well as for complete and perfect contraction, by making

$n = 2$ for perfect and complete contraction (Fig. 557);

$n = 1$ when one end only is flush with side of channel;

$n = 0$ when both ends are flush with sides of channel.

The contraction was considered complete and perfect when the channel of approach was made as wide as practicable, = 13.96 feet, the depth being about 5 feet.

Mr. Francis also experimented with submerged or "drowned" weirs in 1883; such a weir being one in which the sill is below the level of the tail-water (i.e., of receiving channel).

506. Fteley and Stearns's Experiments at Boston, Mass., in 1877 and 1880.—These may be found in the Transactions of the American Society of Civil Engineers, vol. XII, and gave rise to formulæ differing slightly from those of Mr. Francis in some particulars. In the case of *suppressed end-contractions*, like that in Fig. 559, they propose formulæ as follows:

When depth of notch is not large,

$$Q \text{ (in cub. ft. per sec.)} = 3.31 bh_1^{\frac{3}{2}} + 0.007b \quad \dots (15)$$

(b and h_1 both in feet),

" h_1 , the depth on the weir, should be measured from the surface of the water above the curvature of the sheet."

"Air should have free access to the space under the sheet." The crest must be horizontal. The formula does not apply to depths on the weir less than 0.07 feet.

When the depth of notch is quite large, a correction must be made for velocity of approach, c , thus:

$$Q \text{ (in cub. ft. per sec.)} = 3.31 b \left[h_1 + 1.5 \frac{c^2}{2g} \right]^{\frac{3}{2}} + 0.007b \quad (16)$$

(b and h_1 both in feet).

The channel should be of uniform rectangular section for about 20 ft. or more from the weir, to make this correction properly. If G = the cross-section, in sq. ft., of the channel of approach, c is found approximately by dividing an approximate value of Q by G ; and so on for closer results.

The weir may be of any length, b , from 5 to 19 feet.

506a. Recent Experiments on Overfall-weirs in France.—In the *Annales des Ponts et Chaussées* for October 1888 is an account of extensive and careful experiments conducted in 1886 and 1887 by M. Bazin on the flow over sharp-edged overfall-weirs with end-contractions suppressed; i.e., like that shown in Fig. 559. The widths of the weirs ranged from 0.50 to 2.00 metres, and the depths on the weirs (h_2) from 0.05 to 0.60 metre. With p indicating the height of the sill of the weir from the bottom of the channel of approach, M. Bazin, as a practical result of the experiments, recommends the following formula as giving a reasonably accurate value for the volume of discharge per unit of time:

$$Q = \frac{2}{3} \mu' \left[1 + 0.55 \left(\frac{h_2}{p + h_2} \right)^2 \right] b h_2 \sqrt{2g h_2}, \dots (17)$$

where the coefficient μ' has a value

$$\mu' = 0.6075 + \frac{0.0148}{h_2 \text{ (in ft.)}}, \dots (18)$$

Eq. (17) is homogeneous, i.e., admits of any system of units.

Provision was made in these experiments for the free entrance of air under the sheet (a point of great importance), while the walls of the channel of approach were continued down-stream, beyond the plane of the weir, to prevent any lateral expansion of the sheet. The value of p ranged from 0.20 to 2.00 metres.

Herr Ritter von Wex in his "*Hydrodynamik*" (Leipsic, 1888) derives formulæ for weirs, in the establishing of which some rather peculiar views in the Mechanics of Fluids are advanced.

Formulæ and tables for discharge through orifices or over weirs of some forms not given here may be found in the works of Weisbach, Rankine, and Trautwine.

Mr. Hamilton Smith, a noted American hydraulic engineer, has recently published "Hydraulics," a valuable compilation and résumé of the most trustworthy experiments in all fields of hydraulics (New York, 1886: John Wiley & Sons).

507. Efflux through Short Cylindrical Tubes.—When efflux takes place through a short cylindrical tube, or "short pipe," at least $2\frac{1}{2}$ times as long as wide, inserted at right angles in the plane side of a large reservoir, the inner corners *not rounded* (see Fig. 560), the jet issues from the tube in parallel filaments and with a sectional area, F_m , equal to that, F , of interior of tube.

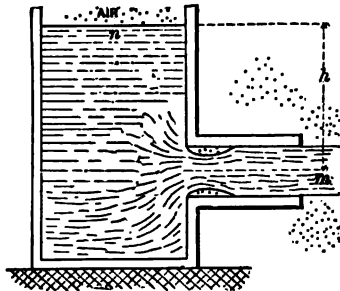

To attain this result, however, the tube must be full of water before the outer end is unstopped, and must not be oily; nor must the head, h , be greater than about 40 ft. for efflux into the air. Since at m the filaments are parallel and the pressure-head therefore equal to b ($= 34$ ft. of water, nearly), $=$ that of surrounding medium, $=$ head due to one atmosphere in this instance; an application of Bernoulli's Theorem [eq. (7), § 492] to positions m and n would give (precisely as in §§ 454 and 455)

$$v_m = \text{veloc. at } m = \sqrt{2gh}$$

as a theoretical result; but experiment shows that the actual value of v_m in this case is

$$v_m = \phi_0 \sqrt{2gh} = 0.815 \sqrt{2gh}, \dots \dots (1)$$

0.815 being an average value for ϕ_0 , the *coefficient of velocity*, for ordinary purposes. It increases slightly as the head decreases,

and is evidently much less than the value 0.97 for an orifice in a thin plate, § 495, or for a rounded mouth-piece as in § 496.

But as the sectional area of the stream where the filaments are parallel, at m , where $v_m = 0.815 \sqrt{2gh}$, is also equal to that, F , of the tube, the coefficient of efflux, μ , in the formula

$$Q = \mu_c F \sqrt{2gh},$$

is equal to ϕ ; i.e., there is no contraction, or the coefficient of contraction, C , in this case = 1.00.

Hence, for the volume of discharge per unit of time, we have practically

$$Q = \phi_c F \sqrt{2gh} = 0.815 F \sqrt{2gh} \dots (2)$$

The discharge is therefore about $\frac{1}{8}$ greater than through an orifice of the same diameter in a thin plate under the same head [compare eq. (3), § 495]; for although at m the velocity is less in the present case, the *sectional area of the stream is greater*, there being no contraction.

This difference in velocity is due principally to the fact that the entrance of the tube has square edges, so that the stream contracts (at m' , Fig. 561) to a section smaller than that of the tube, and then *re-expands* to the full section, F , of tube. The eddying and accompanying internal friction caused by this re-expansion (or "sudden enlargement" of the stream) is the principal *resistance* which diminishes

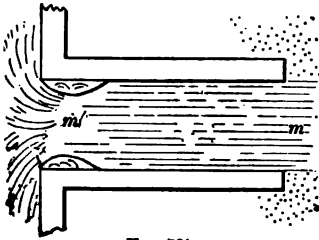

FIG. 561.

the velocity. It is noticeable, also, in this case that the jet is not limpid and clear, as from thin plate, but troubled and only translucent (like ground-glass). The internal pressure in the stream at m' is found to be *less than one atmosphere*, i.e. less than that at m , as shown experimentally by the sucking in of air when a small aperture is made in the tube op-

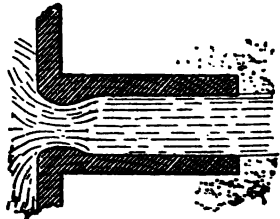

FIG. 562.

posite m' . If the tube itself were so formed internally as to fit this contracted vein, as in Fig. 562, the eddying would be diminished and the velocity at m increased, and hence the volume Q of efflux increased in the same proportion. (See § 509a.)

If the tube is less than $2\frac{1}{2}$ times as long as wide, or if the interior is *not wet by the water* (as when greasy), or if the head is over 40 or 50 ft. (about), the efflux takes place as if the tube were not there, Fig. 563, and we have

$$v_m = 0.97 \sqrt{2gh}, \text{ as in § 495.}$$

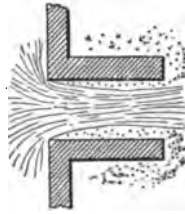

FIG. 563.

EXAMPLE.—The discharge through a short pipe 3 inches in diameter, like that in Fig. 560, is 30 cub. ft. per minute, under a head of 2' 6'', reservoir large. Required the coefficient of efflux $\mu_e = \phi_e$, in this case. For variety use the *inch-pound-minute* system of units, in which $g = 32.2 \times 12 \times 3600$ (see Note, § 51). μ_e , being an abstract number, will be the same numerically in any system of units.

From eq. (2),

$$\begin{aligned} \phi_e = \mu_e &= \frac{Q}{F\sqrt{2gh}} = \frac{30 \times 1728}{\frac{\pi}{4} \times 3^2 \sqrt{2} \times 32.2 \times 12 \times 60^3 \times 30} \\ &= 0.803. \end{aligned}$$

508. Inclined Short Tubes (Cylindrical).—Fig. 564. If the short tube is inclined at some angle $\alpha < 90^\circ$ to the interior plane of the reservoir wall, the efflux is smaller than when the angle is 90° , as in § 507.

We still use the form of equation

$$Q = \mu F \sqrt{2gh} = \phi F \sqrt{2gh}; \quad (3)$$

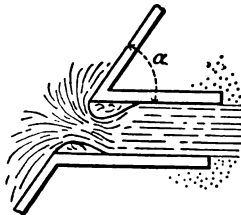

FIG. 564.

but from Weisbach's experiments μ should be taken from the following table:

TABLE F, COEFFICIENT OF EFFLUX (INCLINED TUBE).

For $\alpha = 90^\circ$ take $\mu = \phi = .815$	80° .799	70° .783	60° .764	50° .747	40° .731	30° .719
-----------------------------------------------------	--------------------	--------------------	--------------------	--------------------	--------------------	--------------------

EXAMPLE.—With $h = 12$ ft., $d =$ diam. of tube $= 4$ ins., and $\alpha = 46^\circ$, we have for the volume discharged per sec. (ft., lb., and sec.)

$$Q = [0.731 + \frac{1}{10} (.016)] \frac{\pi}{4} \left(\frac{1}{3}\right)^3 \sqrt{64.4 \times 12} = 1.79 \text{ cub.ft. per sec.}$$

The tube must be at least 3 times as long as wide, to be filled.

509. **Conical Diverging, and Converging, Short Tubes.**—With *conical convergent tubes*, as at *A*, Fig. 565, with inner edges not rounded, D'Aubuisson and Castel found by experiment values of the coefficient of velocity, ϕ , and of that of efflux, μ , [from which the coefficient of contraction, $C = \mu \div \phi$, may be

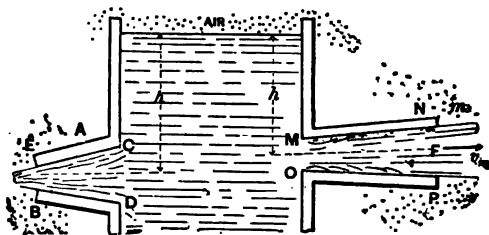

FIG. 565.

computed,] for tubes 1.55 centimeters wide at the narrow end, and 4.0 centimeters long, under a head of $h = 3$ metres, and with different angles of convergence. By angle of convergence is meant the angle between the sides *CE* and *DB*. Fig. 565. In the following table will be found some values of μ and ϕ founded on these experiments, for use in the formulæ

$$v_m = \phi \sqrt{2gh} \quad \text{and} \quad Q = \mu F \sqrt{2gh};$$

in which F denotes the area of the outlet orifice *EB*.

TABLE G (CONICAL CONVERGING TUBES).

Angle of convergence } = 3° 10'	8°	10° 20'	13° 30'	19° 30'	30°	49°
$\mu = .895$.930	.938	.946	.924	.895	.847
$\phi = .894$.933	.951	.933	.970	.975	.984

Evidently μ is a maximum for 13½°.

With a conically divergent tube as at *MN*, having the internal diameter *MO* = .025 metre, the internal diam. *NP* = .032 metre, and the angle between *MN* and *PO* = 4° 50', Weisbach found that in the equation $Q = \mu F \sqrt{2gh}$ (where *F* = area of outlet section *NP*) μ should be = 0.553; the great loss of velocity as compared with $\sqrt{2gh}$ being due to the eddying in the re-expansion from the contracted section at *M* (corners not rounded), as occurs also in Fig. 549. The jet was much troubled and pulsated violently.

When the angle of divergence is too great, or the head *h* too large, or if the tube is not wet by the water, efflux with the tube filled cannot be maintained, the flow then taking place as in Fig. 563.

Venturi and Eytelwein experimented with a conically divergent tube (called now "*Venturi's tube*"), with rounded entrance to conform to the shape of the contracted vein, as in Fig. 566, having a diameter of one inch at *m'* (narrowest part), where the sectional area = *F'* = 0.7854 sq. in., and of 1.80

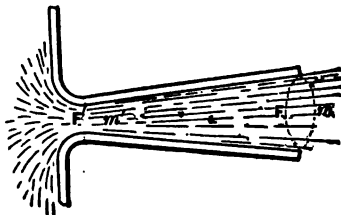

FIG. 566.

inches at *m* (outlet), where area = *F*; the length being 8 ins., and the angle of convergence 5° 9'.

With $Q = \mu F \sqrt{2gh}$ they found $\mu = 0.483$.

Hence 2½ times as much water was discharged as would have flowed out under the same head through an orifice in thin plate with area = *F'* = the *smallest* section of the divergent tube, and 1.9 times as much as through a short pipe of section = *F'*. A similar calculation shows that the velocity at *m'* must have been $v_{m'} = 1.55 \sqrt{2gh}$, and hence that the pressure at *m'* was much less than one atmosphere.

Mr. J. B. Francis also experimented with Venturi's tube (see "Lowell Hydraulic Experiments"). See also p. 389 of vol. 6 of the Journal of Engineering Societies, for experiments with diverging short tubes discharging under water. The highest coefficient (μ) obtained by Mr. Francis was 0.782.

509a. *New Forms of the Venturi Tube.*—The statement made in § 507, in connection with Fig. 562, was based on purely theoretic grounds, but has recently (Dec. 1888) been completely verified by experiments* conducted in the hydraulic laboratory of the College of Civil Engineering at Cornell University. Three short tubes of circular section, each 3 in. in length and 1 in. in internal diameter at *both* ends, were experimented with, under heads of 2 ft. and 4 ft. Call them A, B, and C. A was an ordinary straight tube as in Fig. 561; the longitudinal section of B was like that in Fig. 562, the narrowest diameter being 0.80 in. [see § 495; $(0.8)^2 = 0.64$]; while C was somewhat like that in Fig. 566, being formed like B up to the narrowest part (diameter 0.80 in.), and then made conically divergent to the discharging end. The results of the experiments are given in the following table:

Name of Tube.	Head.	Number of Experiments.	Range of Values of μ .	Average Values of μ .
A	$h = 2$ ft.	4	From 0.804 to 0.823	0.814
A	$h = 4$ ft.	3	" 0.819 to 0.823	0.821
B	$h = 2$ ft.	5	" 0.875 to 0.896	0.882
B	$h = 4$ ft.	4	" 0.881 to 0.903	0.892
C	$h = 2$ ft.	5	" 0.890 to 0.919	0.901
C	$h = 4$ ft.	4	" 0.902 to 0.923	0.914

The fact that B discharges more than A is very noticeable, while the superiority of C to B, though evident, is not nearly so great as that of B to A, showing that in order to increase the discharge of an (originally) straight tube (by *encroaching* on the passage-way) it is of more importance to fill up with solid substance the space around the contracted vein than to make the transition from the narrow section to the discharging end very gradual.

* See Journal of the Franklin Inst., for April, 1889.

510. “Fluid Friction.”—By experimenting with the flow of water in glass pipes inserted in the side of a tank, Prof. Reynolds of England has found that the flow goes on in parallel filaments for only a few feet from the entrance of the tube, and that then the liquid particles begin to intermingle and cross each other’s paths in the most intricate manner. To render this phenomenon visible, he injected a fine stream of colored liquid at the inlet of the pipe and observed its further motion, and found that the greater the velocity the nearer to the inlet was the point where the breaking up of the parallelism of flow began. The hypothesis of laminated flow is, nevertheless, the simplest theoretical basis for establishing practical formulæ, and the resistance offered by pipes to the flow of liquids in them will therefore be attributed to the friction of the edges of the laminæ against the inner surface of the pipe.

The amount of this resistance (often called *skin-friction*) for a given extent of rubbing surface is by experiment found—

1. To be *independent of the pressure* between the liquid and the solid ;
2. To vary nearly with the *square of the relative velocity* ;
3. To vary directly with the *amount of rubbing surface* ;
4. To vary directly with the *heaviness* [γ , § 409] of the liquid.

Hence for a given velocity v , a given rubbing surface of area = S , and a liquid of heaviness γ , we may write

$$\text{Amount of friction (force)} = fS\gamma \frac{v^2}{2g}, \quad (1)$$

in which f is an abstract number called the *coefficient of fluid friction*, to be determined by experiment. For a given liquid, given character (roughness) of surface, and small range of velocities it is approximately constant. The object of introducing the $2g$ is not only because $\frac{v^2}{2g}$ is a familiar and useful function of v , but that $v^2 \div 2g$ is a *height*, or distance, and therefore the product of S (an area) by $v^2 \div 2g$ is a *volume*, and this volume multiplied by γ gives the *weight* of an ideal prism of

the liquid; hence $S \frac{v^2}{2g} \gamma$ is a *force* and f must be an *abstract number* and therefore the same in all systems of units, in any given case or experiment.

In his experiments at Torquay, England, the late Mr. Froude found the following values for f , the liquid being salt water, while the rigid surfaces were the two sides of a thin straight wooden board $\frac{3}{8}$ of an inch thick and 19 inches high, coated or prepared in various ways, and drawn edgewise through the water at a constant velocity, the total resistance being measured by a dynamometer.

511. Mr. Froude's Results.—(Condensed.) [The velocity was the same = 10 ft. per sec. in each of the following cases. For other velocities the resistance was found to vary nearly as the square of the velocity, the index of the power varying from 1.8 to 2.16.]

TABLE H.

Character of Surface.	Value of f [from eq. (1), § 510].			
	When the board was			
	2 ft. long.	8 ft. long.	30 ft. long.	50 ft. long.
Varnish..... $f =$	0.0041	0.0082	0.0028	0.0025
Paraffine..... "	.0088	.0081	.0027
Tinfoil.....	.0030	.0028	.0026	.0025
Calico.....	.0087	.0063	.0053	.0047
Fine Sand.....	.0081	.0058	.0048	.0040
Medium Sand.....	.0090	.0062	.0053	.0049
Coarse Sand.....	.0110	.0071	.0059

N.B. These numbers multiplied by 100 also give the mean frictional resistance in lbs. per sq. foot of area of surface in each case ($v = 10'$ per sec.), considering the heaviness of sea water, 64 lbs. per cubic foot, to cancel the $2g = 64.4$ ft. per sq. sec. of eq. (1) of the preceding paragraph.

For use in formulæ bearing on flow in pipes, f is best determined directly by experiments of that very nature, the results of which will be given as soon as the proper formulæ have been established.

512. Bernoulli's Theorem for Steady Flow, with Friction.—[The student will now re-read the first part of § 492, as far as eq. (1).] Considering free any lamina of fluid, Fig. 567, (according to the subdivision of the stream agreed upon in § 492 referred

to,) the frictions on the edges are the only additional forces as compared with the system in Fig. 534. Let w denote the length of the *wetted perimeter* of the base of this lamina (in case of a pipe running full, as we here postulate, the wetted perimeter is of course the *whole perimeter*, but in the case of an open channel or canal, w is only a portion of the whole perimeter of the cross-section). Then, since the area of rubbing surface at the edge is $S = wds'$, the total friction for the lamina is [by eq. (1), § 510] $= fwy(v^2 \div 2g)ds'$. Hence from $vdv = (\text{tan. accel.}) \times ds$, and from $(\text{tan. accel.}) = [\Sigma(\text{tang. comps. of acting forces})] \div (\text{mass of lamina})$, we have

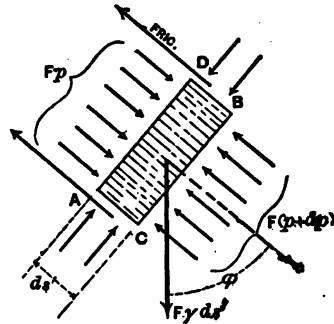

FIG. 567.

$$vdv = \frac{Fp - F(p + dp) + Fyds' \cos \phi - fwy \frac{v^2}{2g} ds'}{Fyds' \div g} \cdot ds \dots (a)$$

As in § 492, so here, considering the simultaneous advance of all the laminae lying between any two sections m and n during the small time dt , putting $ds' = ds$, and $ds' \cos \phi = -dz$ (see Fig. 568), we have, for any one lamina,

$$\frac{1}{g} vdv + \frac{1}{\gamma} dp + dz = -f \frac{w}{F} \cdot \frac{v^2}{2g} ds \dots (1)$$

Now conceive an infinite number of equations to be formed like eq. (1), one for each lamina between n and m , for the same dt , viz., a dt of such length that each lamina at the end of dt will occupy the same position, and acquire the same values of v , z , and p , that the lamina next in front had at the beginning of the dt (this is the characteristic of a *steady flow*). Adding up

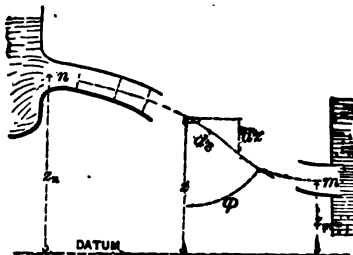

FIG. 568.

the corresponding terms of all these equations, we have (remembering that for a liquid γ is the same in all laminæ),

$$\frac{1}{g} \int_n^m v dv + \frac{1}{\gamma} \int_n^m dp + \int_n^m dz = - \frac{f}{2g} \cdot \int_n^m \frac{w}{F} v^2 ds; \quad (2)$$

i.e., after transposition and writing R for $F \div w$, for brevity,

$$\frac{v_m^2}{2g} + \frac{p_m}{\gamma} + z_m = \frac{v_n^2}{2g} + \frac{p_n}{\gamma} + z_n - \frac{f}{2g} \int_n^m \frac{v^2 ds}{R}. \quad (3)$$

This is *Bernoulli's Theorem for steady flow of a liquid in a pipe of slightly varying sectional area F , and internal perimeter w* , taking into account no resistances or friction, except the "skin-friction," or "fluid-friction," of the liquid and sides of the pipe.

Resistances due to the internal friction of eddying occasioned by sudden enlargements of the cross-section of the pipe, by elbows, sharp curves, valve-gates, etc., will be mentioned later. The negative term on the right in (3) is of course a *height or head* (one dimension of length), as all the other terms are such, and since it is the amount by which the sum of the three heads (viz., *velocity-head*, *pressure-head*, and *potential head*) at m , the down-stream position, *lacks* of being equal to the sum of the corresponding heads at n , the up-stream position or section, we may call it the "*Loss of Head*" due to skin-friction between n and m ; also called *friction-head*, or *resistance-head*, or *height of resistance*.

The quantity $R = F \div w = \text{sectional-area} \div \text{wetted-perimeter}$, is an imaginary distance or length called the *Hydraulic Mean Radius*, or *Hydraulic Mean Depth*, or simply *hydraulic radius* of the section. For a circular pipe of diameter = d ,

$$R = \frac{1}{4} \pi d^2 \div \pi d = \frac{1}{4} d;$$

while for a pipe of rectangular section,

$$R = \frac{ab}{2(a+b)}.$$

513. Problems involving Friction-heads; and Examples of Bernoulli's Theorem with Friction.

PROBLEM I.—Let the portion of pipe between n and m be level, and of uniform circular section and diameter = d . The jet at m discharges into the air, and has the same sectional area, $F = \frac{1}{4}\pi d^2$, as the pipe; then the pressure-head at m is

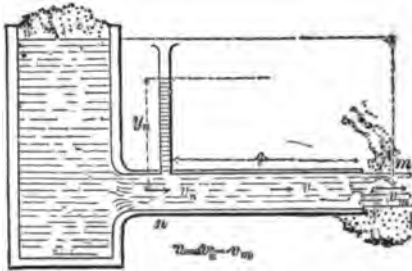

FIG. 569.

$\frac{p_m}{\gamma} = b = 34$ feet (for water), and the velocity-head at m is = that at n , since $v_m = v_n$. The height of the water column in the open piezometer at n is noted, and = y_n (so that the pressure-head at n is $\frac{p_n}{\gamma} = y_n + b$); while the length of pipe from n to m is = l .

Knowing l, d, y_n , and having measured the volume Q , of flow, per unit of time, it is required to find the form of the friction-head and the value of f . From

$$F_m v_m = Q, \text{ or } \frac{1}{4}\pi d^2 v_m = Q, \dots (1)$$

v_m becomes known. Also, v_m is known to be = v_n , and the velocity at each ds is $v = v_m$, since F (sectional area) is constant along the pipe, and $Fv = Q$. The hydraulic radius is

$$R = \frac{1}{4}d; \dots (2)$$

the same for all the ds 's between n and m .

Substituting in eq. (3) of § 512, with the horizontal axis of the pipe as a datum for potential heads, we have

$$\frac{v_m^2}{2g} + b + 0 = \frac{v_n^2}{2g} + y_n + b + 0 - \frac{f}{4d} \cdot \frac{v_m^2}{2g} \int_n^m ds; \dots (3)$$

i.e., since $\int_n^m ds = l =$ length of pipe from n to m , the friction-head for a pipe of length = l , and uniform circular section of diameter = d , reduces to the form

$$\text{Friction-head} = 4f \frac{l}{d} \cdot \frac{v^2}{2g}; \dots (4)$$

where v = velocity of water in the pipe, being in this case also = v_m and = v_n . Hence this friction-head varies directly as the length and as the square of the velocity, and inversely as the diameter; also directly as the coefficient f .

From (3), then, we derive (for this particular problem)

$$\text{Piezometer-height at } n = y_n = 4f \frac{l}{d} \cdot \frac{v^2}{2g}; \dots (5)$$

i.e., the open piezometer-height at n is equal to the loss of head (all of which is friction-head here) sustained between n and the mouth of the pipe. (Pipe horizontal.)

EXAMPLE.—Required the value of f , knowing that $d = 3$ in., y_n (by observation) = 10.4 ft., and $Q = 0.1960$ cub. ft. per sec., while $l = 400$ ft. (n to m). From eq. (1) we find, in ft.-lb.-sec. system, the velocity in the pipe to be

$$v = \frac{4Q}{\pi d^2} = \frac{4 \times 0.1960}{\pi \frac{1}{8}} = 4.0 \text{ ft. per sec.};$$

then, using eq. (5), we determine f to be

$$f = \frac{2gy_n d}{4lv^2} = \frac{2 \times 32.2 \times \frac{1}{4} \times 10.4}{4 \times 400 \times 4^2} = 0.0065.$$

PROBLEM II. *Hydraulic Accumulator.*—Fig. 570. Let the area F_n of the piston on the left be quite large compared with

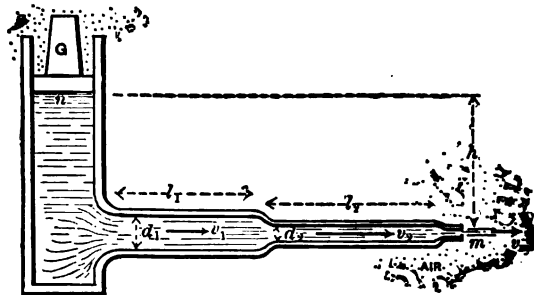

FIG. 570.

that of the pipes and nozzle. The cylinder contains a friction-

less weighted piston, producing (so long as its downward *slow* motion is uniform) a fluid pressure on its lower face of an intensity $p_n = [G + F_n p_a] \div F_n$ per unit area ($p_a =$ one atmos.).

Hence the pressure-head at n is

$$\frac{p_n}{\gamma} = \frac{G}{F_n \gamma} + b, \quad (6)$$

where $G =$ load on piston.

The jet has a section at $m = F_m =$ that of the small straight nozzle (no contraction). The junctions of the pipes with each other, and with the cylinder and nozzle, are all smoothly rounded; hence the only losses of head in steady flow between n and m are the friction-heads in the two long pipes, neglecting that in the short nozzle. These friction-heads will be of the form in eq. (4), and will involve the velocities v_1 and v_2 , respectively in these pipes (*supposed* running full). v_1 and v_2 may be unknown at the outset, as here.

Knowing G and all dimensions and heights, we are required to find the velocity v_m of the jet, flowing into the air, and the volume of flow, Q , per unit of time, assuming f to be known and to be the same in both pipes (not strictly true).

Let the lengths and diameters be denoted as in Fig. 570, their sectional areas F_1 and F_2 , the unknown velocities in them v_1 and v_2 .

From the *equation of continuity* [eq. (3), § 490], we have

$$v_1 = \frac{F_m v_m}{F_1} \quad \text{and} \quad v_2 = \frac{F_m v_m}{F_2}. \quad . . . (7)$$

To find v_m , we apply Bernoulli's Theorem (with friction), eq. (3), § 512, taking the down-stream position m in the jet close to the nozzle, and the up-stream position n just under the piston in the cylinder where the velocity v_n is practically nothing. Then with m as datum plane we have

$$\frac{v_m^2}{2g} + b + 0 = 0 + \frac{p_n}{\gamma} + h - 4f \frac{l_1}{d_1} \cdot \frac{v_1^2}{2g} - 4f \frac{l_2}{d_2} \cdot \frac{v_2^2}{2g}. \quad (8)$$

Apparently (8) contains three unknown quantities, v_m , v_1 , and v_2 ; but from eqs. (7) v_1 and v_2 can be expressed in terms of v_m , whence [see also eq. (6)]

$$\frac{v_m}{2g} \left[1 + 4f \frac{l_1}{d_1} \left(\frac{F_m}{F_1} \right)^5 + 4f \frac{l_2}{d_2} \left(\frac{F_m}{F_2} \right)^5 \right] = h + \frac{G}{F_m \gamma}; \quad (9)$$

or, finally,

$$v_m = \frac{\sqrt{2g \left(h + \frac{G}{F_m \gamma} \right)}}{\sqrt{1 + 4f \frac{l_1}{d_1} \left(\frac{F_m}{F_1} \right)^5 + 4f \frac{l_2}{d_2} \left(\frac{F_m}{F_2} \right)^5}}; \quad (10)$$

and hence we have also

$$Q = F_m v_m. \quad (11)$$

EXAMPLE.—If we replace the force G of this problem by the thrust P exerted along the pump-piston of a steam fire-engine, we may treat the foregoing as a close approximation to the practical problem of such an apparatus, the pipes being consecutive straight lengths of hose, in which (for the probable values of v_1 and v_2) we may take $f = .0075$ (see "Fire-streams," by Geo. Ellis, Springfield, Mass.)* (Strictly, f varies somewhat with the velocity; see § 517.) Let $P = 12000$ lbs., and the piston-area at $n = F_n = 72$ sq. in. = $\frac{1}{4}$ sq. ft. Also, let $h = 20$ ft., and the dimensions of the hose be as follows:

$$d_1 = 3 \text{ in.}, \quad d_2 = 2 \text{ in.}, \quad d_n \text{ (of nozzle)} = 1 \text{ in.};$$

$$l_1 = 400 \text{ ft.}, \quad l_2 = 500 \text{ ft.}$$

With the foot-pound-second system of units, we now have [eq. (10)]

$$v_m = \sqrt{\frac{2 \times 32.2 \left[20 + \frac{12000}{\frac{1}{4} \times 62.5} \right]}{1 + 4 \times .0075 \left[\frac{400}{\frac{1}{4}} \left(\frac{1}{9} \right)^5 + \frac{500}{\frac{1}{4}} \left(\frac{1}{4} \right)^5 \right]}}$$

* See § 578.

$$= \sqrt{\frac{2 \times 32.2 \times 404}{1 + 0.59 + 5.62}};$$

i.e., $v_m = 60.0$ ft. per sec. If this jet were directed vertically upward it should theoretically attain a height $= \frac{v_m^2}{2g} =$ nearly 56 feet, but the resistance of the air would reduce this to about 40 or 45 ft.

We have further, from eq. (1),

$$Q = F_m v_m = \frac{\pi}{4} \left(\frac{1}{12} \right)^2 \times 60.0 = 3.27 \text{ cub. ft. per sec.}$$

If there were no resistance in the hose we should have, from § 497a,

$$v_m = \sqrt{2g \left[\frac{P}{F_n \gamma} + h \right]} = \sqrt{2 \times 32.2 \times 404} = 161.3 \text{ ft. per sec.}$$

513a. Influence of Changes of Temperature.—Although Poiseuille and Hagen found that with glass tubes of very small diameter the flow of water was increased threefold by a rise of temperature from 0° to 45° Cent., it is unlikely that with common pipes the rate of flow is appreciably affected by the ordinary fluctuations of temperature; at any rate, experiments of sufficient precision are wanting, as regards such an influence. See Mr. Hamilton Smith's "Hydraulics," p. 16, where he says: "Changes by variation in T (temperature) will probably only be appreciable with small orifices, or with very low heads for orifices or weirs."

514. Loss of Head in Orifices and Short Pipes.—So long as the steady flow between two localities n and m takes place in a pipe having *no abrupt* enlargement or diminution of section, nor sharp curves, bends, or elbows, the loss of head may be ascribed solely to the surface action (or "skin-friction") between water and pipe; but the introduction of any of the above-mentioned features occasions eddying and internal disturbance, and friction (and consequent heat): thereby causing further deviations

from Bernoulli's Theorem; i.e., additional *losses of head*, or *heights of resistance*.

From the analogy of the form of a friction-head in a long pipe [eq. (4), § 513], we may assume that any of the above heights of resistance is proportional to the square of the velocity, and may therefore always be written in the form

$$\left\{ \begin{array}{l} \text{Loss of Head due to any} \\ \text{cause except skin-friction} \end{array} \right\} = \zeta \frac{v^2}{2g}, \quad \dots \dots \dots (1)$$

in which v is the velocity of the water in the pipe at the section where the resistance occurs; or if, on account of an abrupt enlargement of the stream-section, there is a corresponding diminution of velocity, then v is *always to denote this diminished velocity* (i.e., in the down-stream section). This velocity v is often an unknown at the outset.

ζ , corresponding to the abstract factor $4f \frac{l}{d}$ in the height of resistance due to skin-friction [eq. (4), § 513], is an abstract number called the **Coefficient of Resistance**, to be determined experimentally; or computed theoretically, where possible. Roughly speaking, it is independent of the velocity, for a given fitting, casing, pipe-joint, elbow, bend, valve-gate at a definite opening, etc., etc.

515. Heights of Resistance (or Losses of Head) Occasioned by Short Cylindrical Tubes.—When dealing with short tubes discharging into the air, in § 507, deviations from Bernoulli's Theorem were made good by using a *coefficient of velocity* ϕ , dependent on experiment. This device answered every purpose for the simple circumstances of the case, as well as for simple orifices. But the great variety of possible designs of a compound pipe (with skin-friction, bends, sudden changes of cross-section, etc.) renders it almost impossible, in such a pipe, to provide for deviations from Bernoulli's Theorem by a single coefficient of velocity (velocity of jet, that is) for the pipe *as a whole*, since new experiments would be needed for each new design of pipe. Hence the great utility of the conception of "loss of head," one for each source of resistance.

If a long pipe issues from the plane side of a reservoir and the corners of the junction are not rounded [see Fig. 571], we shall need an expression for the loss of head at the entrance, E , as well as that

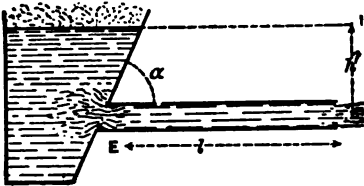

FIG. 571.

$$\left[= 4f \frac{l}{d} \cdot \frac{v^2}{2g} \right]$$

due to the skin-friction in the pipe. But, whatever the velocity, v , in the pipe proves to be, influenced as it is both by the entrance loss of head and the skin-friction head (in applying Bernoulli's Theorem), the loss of head at E , viz., $\zeta_E \frac{v^2}{2g}$, will be just the same as if efflux took place through enough of the pipe at E to constitute a "short pipe," discharging into the air, under *some* head h (different from h' of Fig. 571) sufficient to produce the same velocity v . But in that case we should have

$$v = \phi \sqrt{2gh}, \quad \text{or} \quad \frac{v^2}{2g} = \phi^2 h. \quad \dots \quad (1)$$

(See §§ 507 and 508, ϕ being the "coefficient of velocity," and h the head, in the cases mentioned in those articles.)

We therefore apply Bernoulli's Theorem to the cases of those articles (see Figs. 560 and 564) in order to determine the loss of head due to the short pipe, and obtain (with m as datum level for potential heads)

$$\frac{v_m^2}{2g} + b + 0 = 0 + b + h - \zeta_E \frac{v^2}{2g}. \quad \dots \quad (2)$$

Now the v of eq. (2) is equal to the v_m of the figures referred to, and ζ_E is a *coefficient of resistance* for the short pipe, and we now desire its value. Substituting for

$$\frac{v^2}{2g} \left[= \frac{v_m^2}{2g} \right]$$

its value $\phi^2 h$ from eq. (1), we have

$$\zeta_E = \frac{1}{\phi^2} - 1. \dots \dots \dots (3)$$

Hence when $\alpha = 90^\circ$ (i.e., the pipe is γ to the inner reservoir surface), we derive

$$\zeta_E = \frac{1}{\phi^2} - 1 = \frac{1}{(0.815)^2} - 1 = 0.505; \dots [\alpha = 90^\circ]; \dots (4)$$

and similarly, for other values of α (taking ϕ from the table, § 508), we compute the following values of ζ_E (corners not rounded) for use in the expression for "loss of head," $\zeta_E \frac{v^2}{2g}$:

For $\alpha = 90^\circ$ $\zeta_E = .505$	80° .565	70° .635	60° .713	50° .794	40° .870	30° .987
---------------------------------------------	--------------------	--------------------	--------------------	--------------------	--------------------	--------------------

From eq. (4) we see that the loss of head at the entrance of the pipe, corners not rounded, with $\alpha = 90^\circ$, is about one half (.505) of the height due to the velocity v in that part of the pipe (v being the same all along the pipe if cylindrical). The value of v itself, Fig. 571, depends on *all* the features of the design from reservoir to nozzle. See § 518.

If the corners at E are properly rounded, the entrance loss of head may practically be done away with; still, if v is quite small (as it may frequently be, from large losses of head farther down-stream), the saving thus secured, while helping to increase v slightly (and thus the saving itself), is insignificant.

516. General Form of Bernoulli's Theorem, considering all Losses of Head.

In view of preceding explanations and assumptions, we may write in a general and final form Bernoulli's Theorem for a steady flow from an up-stream position n to a down-stream position m , as follows:

$$\frac{v_m^2}{2g} + \frac{p_m}{\gamma} + z_m = \frac{v_n^2}{2g} + \frac{p_n}{\gamma} + z_n - \left\{ \begin{array}{l} \text{all losses of head} \\ \text{occurring between} \\ n \text{ and } m \end{array} \right\} \cdot (B)$$

Each loss of head (or height of resistance) will be of the form $\zeta \frac{v^2}{2g}$ (except skin-friction head in long pipes, viz., $4f \frac{l}{d} \frac{v^2}{2g}$), the v in each case being the velocity, known or unknown, in that part of the pipe where the resistance occurs (and hence is not necessarily equal to v_m or v_n).

517. The Coefficient, f , for Friction of Water in Pipes.—See eq. (1), § 510. Experiments have been made by Weisbach, Eytelwein, Darcy, Bossut, Prony, Dubuat, Fanning, and others, to determine f in cylindrical pipes of various materials (tin, glass, zinc, lead, brass, cast and wrought iron) of diameters from $\frac{1}{4}$ inch up to 36 inches. In general, the following deductions may be made from these experiments:

1st. f decreases when the velocity increases; e.g., in one case with the

same pipe f was = .0070 for $v = 2'$ per sec.,

while f was = .0056 for $v = 20'$ per sec.

2dly. f decreases slightly as the diameter increases (other things being equal);

e.g., in one experiment f was = .0069 in a 3-in. pipe,

while for the same velocity f was = .0064 in a 6-in. pipe.

3dly. The condition of the interior surface of the pipe affects the value of f , which is larger with increased roughness of pipe.

Thus, Darcy found, with a *foul* iron pipe with $d = 10$ in. and veloc. = 3.67 ft. per sec. the value .0113 for f ; whereas Fanning (see p. 238 of his "Water-supply Engineering"), with a cement-lined pipe and velocity of 3.74 ft. per sec. and $d = 20$ inches, obtained $f = .0052$.

Weisbach, finding the first relation very prominent, proposed the formula

$$f = 0.00359 + \frac{.00429}{\sqrt{v \text{ (in ft. per sec.)}}}$$

when the velocities are great, while Darcy, taking into account both the 1st and 2d relations above, writes (see p. 585, Rankine's Applied Mechanics):

$$f = .0043 \left[1 + \frac{1}{9 \times \text{diam. in ft.}} \right] + \frac{.001}{v \text{ ft. per sec.}} \left[1 + \frac{1}{18 \times \text{diam. in ft.}} \right].$$

For practical purposes, Mr. J. T. Fanning has recommended, and arranged in an extensive table (pp. 242-246 of his book just mentioned), values of f for *clean iron pipe*, of diameters from $\frac{1}{2}$ inch to 96 inches, and for velocities of 0.1 ft. to 20 ft. per second. Of this the table opposite is an abridgment, inserted with Mr. Fanning's permission, for use in solving numerical problems.

In obtaining f for *slightly tuberculated* and for *foul* pipes, the recommendations of Mr. Fanning seem to justify the following rules:

For <i>slightly tuberculated</i> pipes of diams. = $\frac{1}{2}$ ft.	1 ft.	2 ft.	4 ft.
we should add	23%	34%	16%
and for <i>foul</i> pipes of same size	72%	60%	38%
			25%

of the f for clean pipes, to itself. For example, if $f = .007$ for a certain $\frac{1}{2}$ -ft. pipe when clean, with velocity = 0.64 ft. per sec., we have $f = .007 \times 1.72 = .01204$ when it is foul.

For first approximations a mean value of $f = .006$ may be employed, since in some problems sufficient data may not be known in advance to enable us to take f from the table.

EXAMPLE.—Fig. 572. In the steady pumping of crude petroleum weighing $\gamma = 55$ lbs. per cubic foot, through a six-inch pipe 30 miles long, to a station 700 ft. higher than the pump, it is found that the pressure in the pump cylinder at n , necessary to keep up a velocity of 4.4 ft. per sec. in the pipe, is 1000

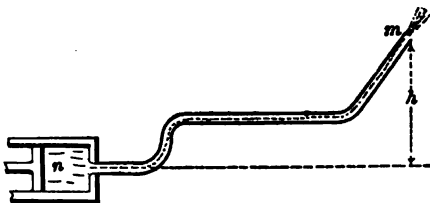

FIG. 572.

lbs. per sq. inch. Required the coefficient f in the pipe. As all losses except the friction-head in the pipe are insignificant, the latter only will be considered. The velocity-head at n may

be put = 0; the jet at m being of the same size as the pipe, the velocity in the pipe is = v_m , and therefore $v_m = 4.4$ ft. per sec. Notice that m , the *down-stream* section, is at a *higher* level than n .

From Bernoulli's Theorem, § 516, we have, with n as a datum level,

$$\frac{v_m^2}{2g} + b + h = 0 + \frac{p_n}{\gamma} + 0 - 4f \frac{l}{d} \frac{v^2}{2g} \quad \dots (1)$$

Using the ft., lb., and sec., we have

$$h = 700 \text{ ft.}, \quad v_m^2 \div 2g = 0.30 \text{ ft.},$$

while

$$b = \frac{14.7 \times 144}{55} = 38.47 \text{ ft.}, \quad \text{and} \quad \frac{p_n}{\gamma} = \frac{1000 \times 144}{55} = 2618 \text{ ft.}$$

Hence, in eq. (1),

$$0.30 + 38.5 + 700 = 2618 - 4f \cdot \frac{30 \times 5280}{\frac{1}{2}} \cdot \frac{(4.4)^2}{64.4}.$$

Solving for f , we have $f = .00485$ (whereas for water, with $v = 4.4$ ft. per sec. and $d = \frac{1}{2}$ ft., the table, p. 709, gives $f = .00601$).

If the γ of the petroleum had been 50 lbs. per cubic foot, instead of 55, we would have obtained $\frac{p_n}{\gamma} = 2880$ feet and $f = .0056$.

518. Flow through a Long Straight Cylindrical Pipe, including both friction-head and entrance loss of head (corners not rounded); reservoir large. Fig. 573.

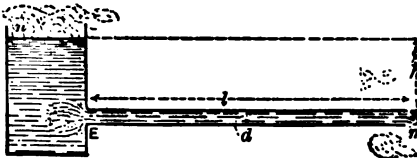

FIG. 573.

The jet issues directly from the end of the pipe, in parallel filaments, into the air, and therefore has same section as pipe; hence, also, v_m of the jet = v in the pipe (which is assumed to be running full), and is

therefore the velocity to be used in the loss of head $\zeta_E \frac{v^2}{2g}$ at the entrance E (§ 515).

Taking m and n as in figure and applying Bernoulli's Theorem (§ 474), with m as datum level for the potential heads z_m and z_n , we have

$$\frac{v_m^2}{2g} + b + 0 = 0 + b + h - \zeta_E \frac{v^2}{2g} - 4f \frac{l}{d} \frac{v^2}{2g}. \quad (1)$$

Three different problems may now be solved:

First, required the head h to keep up a flow of given volume = Q per unit of time in a pipe of given length l and diameter = d .

From the equation of continuity we have

$$Q = F_m v_m = \frac{1}{4} \pi d^2 v_m;$$

$$\therefore \text{veloc. of jet, which} = \text{veloc. in pipe,} = v_m = \frac{4Q}{\pi d^2}. \quad (2)$$

Having found $v_m = v$, from (2), we obtain from (1) the required h , thus:

$$h = \frac{v^2}{2g} \left[1 + \zeta_E + 4f \frac{l}{d} \right]. \quad (3)$$

Now $\zeta_E = 0.505$ if $\alpha = 90^\circ$ (see § 515), while f may be taken from the table, § 517, for the given diameter and computed velocity [$v_m = v$, found in (2)], if the pipe is *clean*; if not clean, see end of § 517, for *slightly tuberculated* and for *foul* pipes.

Secondly. Given the head h , and the length l and diameter d of pipe, required the velocity in the pipe, viz., $v = v_m$, that of jet; also the volume delivered per unit of time, Q . Solving eq. (1) for v_m , we have

$$v_m = \sqrt{\frac{1}{1 + \zeta_E + 4f \frac{l}{d}}} \sqrt{2gh}; \quad (4)$$

whence Q becomes known, since

$$Q = \frac{1}{4}\pi d^2 v_m. \dots \dots \dots (5)$$

[NOTE.—The first radical in (4) might for brevity be called a *coefficient of velocity*, ϕ , for this case. Since the jet has the same diameter as the pipe, this radical may also be called a *coefficient of efflux*.]

Since in (4) f depends on the unknown v as well as on the known d , we must first put $f = .006$ for a first approximation for v_m ; then take a corresponding value for f and substitute again; and so on.

Thirdly, knowing the length of pipe and the head h , we wish to find the proper diameter d for the pipe to deliver a given volume Q of water per unit of time. Now

$$v = v_m = \frac{Q}{\frac{1}{4}\pi d^2}, \dots \dots \dots (6)$$

which substituted in (1) gives

$$2gh = \left(\frac{4Q}{\pi}\right)^2 \frac{1}{d^5} \left[1 + \zeta_E + 4f \frac{l}{d}\right] = \left(\frac{4Q}{\pi}\right)^2 \left[\frac{1 + \zeta_E}{d^5} + \frac{4fl}{d^6}\right];$$

that is,

$$2ghd^5 = \left(\frac{4Q}{\pi}\right)^2 [(1 + \zeta_E)d + 4fl];$$

$$\therefore d = \sqrt[5]{\frac{(1 + \zeta_E)d + 4fl}{2gh} \cdot \left(\frac{4Q}{\pi}\right)^2} \dots \dots \dots (7)$$

As the radical contains d , we first assume a value for d , with $f = .006$, and substitute in (7). With the approximate value of d thus obtained, we substitute again with a new value for f based on an approximate v from eq. (6) (with $d =$ its first approximation), and thus a still closer value for d is derived; and so on. (Trautwine's Pocket-book contains a table of fifth roots and powers.) If l is quite large, we may put $d = 0$ for a first approximation. In connection with these examples, see last figure.

EXAMPLE 1.—What head h is necessary to deliver 120 cub. ft. of water per minute through a clean straight iron pipe 140 ft. long and 6 in. in diameter?

From eq. (2), with ft., lb., and sec., we have

$$v = v_m = [4 \times \frac{1}{16} g] \div \pi(\frac{1}{2})^2 = 10.18 \text{ ft. per sec.}$$

Now for $v = 10$ ft. per sec. and $d = \frac{1}{2}$ ft., we find (in table, § 517) $f = .00549$; and hence, from eq. (3),

$$h = \frac{(10.18)^2}{2 \times 32.2} \left[1 + .505 + \frac{4 \times .00549 \times 140}{\frac{1}{2}} \right] = 12.23 \text{ ft.},$$

of which total head, as we may call it, 1.60 ft. is used in producing the velocity 10.18 ft. per sec. (i.e., $v_m^2 \div 2g = 1.60$ ft.), while 0.808 ft. ($= \zeta_e \frac{v_m^2}{2g}$) is lost at the entrance E (with $\alpha = 90^\circ$), and 9.82 ft. (friction-head) is lost in skin-friction.

EXAMPLE 2.—[Data from Weisbach.] Required the delivery, Q , through a straight clean iron pipe 48 ft. long and 2 in. in diameter, with 5 ft. head ($= h$). $v = v_m$, being unknown, we first take $f = .006$ and obtain [eq. (4)]

$$\begin{aligned} v_m &= \sqrt{\frac{1}{1 + .505 + \frac{4 \times .006 \times 48}{\frac{1}{2}}}} \sqrt{2 \times 32.2 \times 5} \\ &= 6.18 \text{ ft. per sec.} \end{aligned}$$

From the table, § 517, for $v = 6.2$ ft. per sec. and $d = 2$ in., $f = .00638$, whence

$$\begin{aligned} v_m &= \sqrt{\frac{1}{1 + .505 + \frac{4 \times .00638 \times 48}{\frac{1}{2}}}} \sqrt{2 \times 32.2 \times 5} \\ &= 6.04 \text{ ft. per sec.,} \end{aligned}$$

which is sufficiently close. Then, for the volume per second,

$$Q = \frac{\pi}{4} d^2 v_m = \frac{1}{4} \pi (\frac{1}{2})^2 6.04 = 0.1307 \text{ cub. ft. per sec.}$$

[Weisbach's results in this example are

$$v_m = 6.52 \text{ ft. per sec.}$$

and

$$Q = 0.1420 \text{ cub. ft. per sec.,}$$

but his values for f are slightly different.]

EXAMPLE 3.—[Data from Weisbach.] What must be the diameter of a straight clean iron pipe 100 ft. in length, which is to deliver $Q = \frac{1}{2}$ of a cubic foot of water per second under 5 ft. head ($= h$)?

With $f = .006$ (approximately), we have from eq. (7), putting $d = 0$ under the radical for a first trial (ft., lb., sec.),

$$d = \sqrt[5]{\frac{4 \times .006 \times 100}{2 \times 32.2 \times 5} \cdot \left(\frac{1}{2}\right)^3} = \text{about } 0.30 \text{ ft.};$$

whence
$$v = \frac{4Q}{\pi d^2} = 7 \text{ ft. per sec.}$$

For $d = 3.6$ in. and $v = 7$ ft. per sec., we find $f = .00601$; whence, again,

$$d = \sqrt[5]{\frac{1.505 \times .30 + 4 \times .00601 \times 100}{2 \times 32.2 \times 5} \cdot \left(\frac{4}{\pi}\right)^3} = 0.324 \text{ ft.};$$

and the corresponding $v = 6.06$ ft.

For this d and v we find $f = .00609$, whence, finally,

$$d = \sqrt[5]{\frac{1.505 \times .30 + 4 \times .00609 \times 100}{2 \times 32.2 \times 5} \cdot \left(\frac{2}{\pi}\right)^3} = 0.326 \text{ ft.}$$

[Weisbach's result is $d = .318$ ft.]

519. Chézy's Formula.—If, in the problem of the preceding paragraph, the pipe is *so long*, and therefore $l : d$ *so great*, that $4fl \div d$ in eq. (3) is very large compared with $1 + \zeta_x$, we may neglect the latter term without appreciable error; whence eq. (3) reduces to

$$h = 4f \frac{l}{d} \cdot \frac{v_m^2}{2g} \quad \cdot \cdot \quad (\text{pipe very long; Fig. 573}), \quad \cdot \cdot \quad (8)$$

which is known as *Chézy's Formula*. For example, if $l = 1000$ ft. and $d = 2$ in. $= \frac{1}{6}$ ft., and f approx. $= .006$, we have $4f \frac{l}{d} = 144$, while $1 + \zeta_x$ for square corners $= 1.505$ only.

If in (8) we substitute

$$v_m = \frac{Q}{F_m} = Q \div \frac{1}{4}\pi d^2,$$

(8) reduces to

$$h = \frac{64}{\pi^2} \cdot f \frac{l}{d^5} \cdot \frac{Q^2}{2g} \dots \dots \dots \text{(very long pipe)}; \dots \dots \dots (9)$$

so that for a very long pipe, considering f as approximately constant, we may say that to deliver a volume $= Q$ per unit of time through a pipe of given length $= l$, the necessary head, h , is *inversely proportional to the fifth power of the diameter*.

And again, solving (9) for Q , we find that the volume conveyed per unit of time is directly proportional to the *fifth power of the square root of the diameter*; directly proportional to the *square root of the head*; and *inversely proportional to the square root of the length*. (Not true for short pipe; see above example.)

If we conceive of the insertion of a great number of piezometers along the long straight pipe, of uniform section, now under consideration, the summits of the respective water columns maintained in them will lie in a straight line joining the discharging (into the air) end of the pipe with a point in the reservoir surface vertically over the inlet extremity (practically so), and the "slope" of this line (called the *Hydraulic Grade Line* or *Gradient*), i.e., the tangent (or sine; the angle is so small, generally) of the angle which it makes with the horizontal is $= \frac{h}{l}$, and may be denoted by s . Putting also $\frac{1}{4}d = R =$ the hydraulic radius of the section of the pipe, and $v_m = v =$ velocity in pipe, we may transform eq. (8) into

$$v = \sqrt{\frac{2g}{f}} (Rs)^{\frac{1}{2}}; \text{ or, } v = A(Rs)^{\frac{1}{2}}, \dots \dots \dots (10)$$

which is the form by which Mr. Hamilton Smith (see § 506) interprets all the experiments quoted by him on long pipes. As to notation, however, he uses n for A , and r for R . With the foot and second as units, the quantity A (*not an abstract number*) varies approximately between 60 and 140. For a given A we easily find the corresponding f from the relation

$$f = \frac{2g}{A^2}. \text{ If the pipe discharges under water, } h = \text{the difference of elevation of the two reservoirs.}$$

If the pipe is not horizontal, the use of the length of its horizontal projection instead of its actual length in the relation $s = \frac{h}{l}$ occasions an error, but it is in most cases insignificant.

Similarly, if a steady flow is going on in a long pipe of uniform section, at the extremities of *any portion* of which we have measured the piezometer heights (or computed them from the readings of steam or pressure gauges), we may apply eq. (9), putting for h the difference of level of the piezometer summits, and for l the length of the pipe between them.

520. Coefficient f in Fire-engine Hose.*—Mr. Geo. A. Ellis, C.E., in his little book on "Fire-streams," describing experiments made in Springfield, Mass., gives a graphic comparison (p. 45 of his book) of the friction-heads occurring in *rubber hose*, in *leather hose*, and in *clean iron pipe*, each of $2\frac{1}{2}$ in. diameter, with various velocities; on which the following statements may be based: That for the given size of hose and pipe ($d = 2\frac{1}{2}$ in.) the coefficient f for the *leather* and *rubber* hose respectively may be obtained approximately by adding to f for clean iron pipe (and a given velocity) the per cent of itself shown in the accompanying table.

Velocity ft. per sec.	Rubber hose $2\frac{1}{2}$ in. diam.	Leather hose $2\frac{1}{2}$ in. diam.
3.0	50%	300%
6.5	20	80
10	16	48
18	12.5	32
16	12	30

EXAMPLE.—For a clean iron pipe $2\frac{1}{2}$ in. diam., for a velocity = 10 ft. per sec., we have, from § 517, $f = .00593$. Hence for a leather hose of the same diameter, we have, for $v = 10$ ft. per sec.,

$$f = .00593 + .43 \times .00593 = .00848.$$

* For the most recent and exhaustive experiments in this direction see Mr. J. R. Freeman's "Hydraulics of Fire-streams" in the Transac. Am. Soc. C. E. for 1889. (Also p. 832 of this work.)

521. **Bernoulli's Theorem as an Expression of the Conservation of Energy for the Liquid Particles.**—In any kind of flow *without friction, steady or not, in rigid immovable vessels*, the aggregate potential and kinetic energy of the whole mass of liquid concerned is necessarily a constant quantity (see §§ 148 and 149), but *individual particles* (as the particles in the sinking free surface of water in a vessel which is rapidly being emptied) may be continually losing potential energy, i.e., reaching lower and lower levels, without any compensating increase of kinetic energy or of any other kind; but in a *steady flow without friction in rigid motionless vessels*, we may state that the stock of energy of a given particle, or small collection of particles, is *constant* during the flow, provided we recognize a third kind of energy which may be called **Pressure-energy**, or capacity for doing work by virtue of internal fluid pressure; as may be thus explained:

In Fig. 574 let water, with a very slow motion and under a pressure p (due to the reservoir-head + atmosphere-head behind it), be admitted behind a piston the space beyond which is *vacuous*. Let s = length of stroke, and F = the area of piston. At the end of the stroke, by motion of proper valves, communication with the reservoir is cut off on the left of the piston

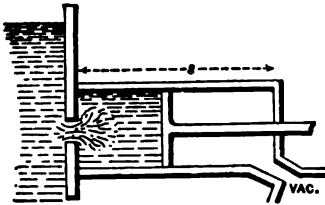

FIG. 574.

and opened on the right, while the water in the cylinder now on the left of the piston is put in communication with the vacuum exhaust-chamber. As a consequence the internal pressure of this water falls to zero (height of cylinder small), and on the return stroke is simply conveyed out of the cylinder, neither helping nor hindering the motion. That is, in doing the work of one stroke, viz.,

$$W = \text{force} \times \text{distance} = Fp \times s = Fps,$$

a volume of water $V = Fs$, weighing Fsy (lbs. or other unit), has been used, and, in passing through the motor, has experienced no appreciable change in velocity (motion slow), and

therefore no change in kinetic energy, nor any change of level, and hence no change in potential energy, *but it has given up all its pressure.* (See § 409 for γ .)

Now W , the work obtained by the consumption of a weight $G = V\gamma$ of water, may be written

$$W = Fps = Fsp = Vp = V\gamma \frac{p}{\gamma} = G \frac{p}{\gamma}. \quad (1)$$

Hence a weight of water $= G$ is capable of doing the work $G \times \frac{p}{\gamma} = G \times$ head due to pressure p , i.e., $= G \times$ pressure-head, in giving up all its pressure p ; or otherwise, while still having a pressure p , a weight G of water possesses an amount of energy, which we may call *pressure-energy*, of an amount $= G \cdot \frac{p}{\gamma}$, where $\gamma =$ the heaviness (§ 7) of water, and $\frac{p}{\gamma} =$ a height, or head, measuring the pressure p ; i.e., it equals the pressure-head.

We may now state Bernoulli's Theorem without friction in a new form, as follows: Multiplying each term of eq. (7), § 451, by $Q\gamma$, the weight of water flowing per second (or other time-unit) in the steady flow, we have

$$Q\gamma \frac{v_m^2}{2g} + Q\gamma \frac{p_m}{\gamma} + Q\gamma z_m = Q\gamma \frac{v_n^2}{2g} + Q\gamma \frac{p_n}{\gamma} + Q\gamma z_n. \quad (2)$$

But $Q\gamma \frac{v_m^2}{2g} = \frac{1}{2} \frac{Q\gamma}{g} v_m^2 = \frac{1}{2} \times$ mass flowing per time-unit \times square of the velocity $=$ the *kinetic energy* inherent in the volume Q of water on passing the section m , due to the velocity at m . Also, $Q\gamma \frac{p_m}{\gamma} =$ the *pressure-energy* of the volume Q at m , due to the pressure at m ; while $Q\gamma z_m =$ the *potential energy* of the volume Q at m due to its height z_m above the arbitrary datum plane. Corresponding statements may be made for the terms on the right-hand side of (2) referring to the other section, n , of the pipe. Hence (2) may be thus read: *The aggregate amount of energy (of the three kinds mentioned) resident in the particles of liquid when passing section m is*

equal to that when passing any other section, as n ; in steady flow without friction in rigid motionless vessels; that is, the store of energy is constant.

522. **Bernoulli's Theorem with Friction, from the Standpoint of Energy.**—Multiply each term in the equation of § 516 by $Q\gamma$, as before, and denote a loss of head or height of resistance due to any cause by h_r , and we have

$$Q\gamma \frac{v_m^2}{2g} + Q\gamma \frac{p_m}{\gamma} + Q\gamma z_m = Q\gamma \frac{v_n^2}{2g} + Q\gamma \frac{p_n}{\gamma} + Q\gamma z_n - \sum_n Q\gamma h_r \dots (3)$$

Each term $Q\gamma h_r$ (e.g., $Q\gamma 4f \frac{l}{d} \frac{v^2}{2g}$ due to skin-friction in a long pipe, and $Q\gamma \zeta_E \frac{v^2}{2g}$ due to loss of head at the reservoir entrance of a pipe) represents a *loss of energy*, occurring between any position n and any other position m down-stream from n , but is really still in existence in the form of heat generated by the friction of the liquid particles against each other or the sides of the pipes.

As illustrative of several points in this connection, consider two short lengths of pipe in Fig. 575, A and B , one offering a gradual, the other a sudden, enlargement of section, but otherwise identical in dimensions. We suppose them to occupy places in separate lines of pipe in each of which a steady flow with full cross-sections is proceeding, and so regulated that the velocity and internal pressure at n , in A , are equal respectively to those at n in B . Hence, if *vacuum* piezometers be inserted at n , the

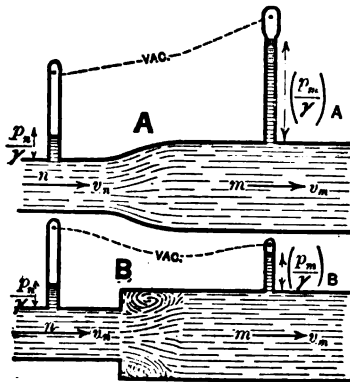

FIG. 575.

smaller section, the water columns maintained in them by the internal pressure will be of the same height, $\frac{p_n}{\gamma}$, for both A and B . Since at m , the larger section, the sectional area is the same for both A and B , and since F_n in $A = F_n$ in B , so that $Q_A = Q_B$, hence v_m in $A = v_m$ in B and is less than v_n .

Now in B a loss of head occurs (and hence a loss of energy) between n and m , but none in A (except slight friction-head); hence in A we should find as much energy present at m as at n , only differently distributed among the three kinds, while at m in B the aggregate energy is less than that at n in B .

As regards kinetic energy, there has been a loss between n and m in both A and B (and equal losses), for v_m is less than v_n . As to potential energy, there is no change between n and m either in A or B , since n and m are on a level. Hence if the loss of kinetic energy in B is not compensated for by an equal gain of pressure-energy (as it is in A), the pressure-head $\left(\frac{p_m}{\gamma}\right)_B$ at m in B should be less than that $\left(\frac{p_m}{\gamma}\right)_A$ at m in A . Experiment shows this to be true, the loss of head being due to the internal friction in the eddy occasioned by the sudden enlargement; the water column at m in B is found to be of a less height than that at m in A , whereas at n they are equal. (See p. 467 of article "Hydromechanics" in the *Ency. Britannica* for Mr. Froude's experiments.)

In brief, in A the loss of kinetic energy has been made up in pressure-energy, with no change of potential energy, but in B there is an actual absolute loss of energy $= Q\gamma h_r$, or $= Q\gamma\zeta \frac{v_m^2}{2g}$, suffered by the weight $Q\gamma$ of liquid. The value of ζ in this case and others will be considered in subsequent paragraphs.

Similarly, losses of head, and therefore losses of energy, occur at elbows, sharp bends, and obstructions, causing eddies and internal friction, the amount of each loss for a given weight, G , of water being $= Gh_r = G\zeta \frac{v^2}{2g}$; $h_r = \zeta \frac{v^2}{2g}$ being the loss of head occasioned by the obstruction (§ 474). It is

therefore very important in transmitting water through pipes for purposes of *power* to use all possible means of preventing disturbance and eddying among the liquid particles. E.g., sharp corners, turns, elbows, abrupt changes of section, should be avoided in the design of the supply-pipe. The amount of the losses of head, or heights of resistance, due to these various causes will now be considered (except skin-friction, already treated). Each such loss of head will be written in the form $\zeta \frac{v^2}{2g}$, and we are principally concerned with the value of the abstract number ζ , or *coefficient of resistance*, in each case. The velocity v is the velocity, known or unknown, *where the resistance occurs*; or if the section of pipe changes at this place, then $v =$ velocity on the *down-stream section*. The late Professor Weisbach, of the mining-school of Freiberg, Saxony, was one of the most noted experimenters in this respect, and will be frequently quoted.

523. Loss of Head Due to Sudden (i.e., Square-edged) Enlargement. Borda's Formula.—Fig. 576.



FIG. 576.

An eddy is formed in the angle with consequent loss of energy. Since each particle of water of weight = G_1 , arriving with the velocity v_1 , in the small pipe, may be considered to have an *impact* against the base of the infinitely great and more slowly moving column of water in the large pipe, and, after the impact, moves on with the same velocity, v_2 , as that column, just as occurs in *inelastic direct central impact* (§ 60), we may find the energy lost by this particle on account of the impact by eq. (1) of § 138, in which, putting $M_1 = G_1 \div g$, and $M_2 = G_2 \div g =$ mass of infinitely great body of water in the large pipe, so that $M_2 = \infty$, we have

$$\text{Energy lost by particle} = G_1 \frac{(v_1 - v_2)^2}{2g}, \quad \dots (1)$$

and the corresponding

$$\text{Loss of head} = \frac{(v_1 - v_2)^2}{2g},$$

which, since $F_1 v_1 = F_2 v_2$, may be written

$$\text{Loss of head in sudden enlargement} = \left[\frac{F_2}{F_1} - 1 \right]^2 \frac{v_2^2}{2g} \quad (2)$$

That is, the coefficient ζ for a sudden enlargement is

$$\zeta = \left(\frac{F_2}{F_1} - 1 \right)^2 \quad (3)$$

F_1 and F_2 are the respective sectional areas of the pipes. Eq. (2) is *Borda's Formula*.

NOTE.—Practically, the flow cannot always be maintained with full sections. In any case, if we *assume* the pipes to be running full (once started so), and on that assumption compute the internal pressure at F_1 , and find it to be zero or negative, the assumption is incorrect. That is, unless there is some pressure at F_1 , the water will not swell out laterally to fill the large pipe.

EXAMPLE.—Fig. 577. In the short tube AB containing a sudden enlargement, we have given $F_2 = F_m = 6$ sq. inches, $F_1 = 4$ sq. inches, and $h = 9$ feet. Required the velocity of the jet at m (in the air, so that $p_m \div \gamma = b = 34$ ft.), if the only loss of head considered is that due to the sudden enlargement (skin-friction neglected, as the tube is short; the reservoir entrance has *rounded corners*). Applying Bernoulli's Theorem to m as down-stream section, and n in reservoir surface as up-stream position (datum level at m), we have

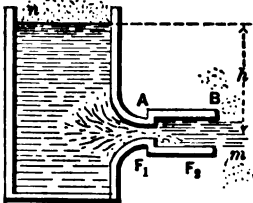

FIG. 577.

$$\frac{v_m^2}{2g} + b + 0 = 0 + b + h - \zeta \frac{v_2^2}{2g} \quad (4)$$

But, here, $v_2 = v_m$;

$$\therefore (1 + \zeta) \frac{v_m^2}{2g} = h \quad (5)$$

From eq. (3) we have

$$\zeta = \left(\frac{6}{4} - 1 \right)^2 = 0.25,$$

and finally (ft., lb., sec.)

$$v_m = \sqrt{\frac{1}{1.25}} \sqrt{2 \times 32.2 \times 9} = 0.895 \sqrt{2 \times 32.2 \times 9}$$

$$= 21.55 \text{ ft. per sec.}$$

(The factor 0.895 might be called a *coefficient of velocity* for this case.) Hence the volume of flow per second is

$$Q = F_m v_m = \frac{9}{144} \times 21.55 = 0.898 \text{ cub. ft. per sec.}$$

We have so far assumed that the water fills both parts of the tube, i.e., that the pressure p_1 , at F_1 , is greater than zero (see foregoing note). To verify this assumption, we compute p_1 by applying Bernoulli's Theorem to the centre of F_1 as down-stream position and datum plane, and n as up-stream position, with no loss of head between, and obtain

$$\frac{v_1^2}{2g} + \frac{p_1}{\gamma} + 0 = 0 + b + h - 0. \dots \dots (6)$$

But since $F_1 v_1 = F_2 v_2$, we have

$$v_1^2 = \left(\frac{1}{4}\right)^2 v_2^2 = \left(\frac{1}{4}\right)^2 v_m^2,$$

and hence the pressure-head at F_1 (substituting from equations above) is

$$\frac{p_1}{\gamma} = b + h - \left(\frac{1}{4}\right)^2 \cdot \frac{h}{1 + \zeta} = 34 + 9 - \frac{9}{4} \cdot \frac{9}{1 + .25} = 27 \text{ feet,}$$

and $\therefore p_1 = \frac{37}{4}$ of $14.7 = 11.6$ lbs. per sq. inch, which is greater than zero; hence efflux with the tube full in both parts can be maintained under 9 ft. head.

If, with F_1 and F_2 as before (and $\therefore \zeta$), we put $p_1 = 0$, and solve for h , we obtain $h = 42.5$ ft. as the maximum head under which efflux with the large portion full can be secured.

524. Short Pipe, Square-edged Internally.—This case, already

treated in §§ 507 and 515 (see Fig. 578; a repetition of 560), presents a loss of head due to the sudden enlargement from the contracted section at m' (whose sectional area may be put = CF , C being an unknown coefficient, or ratio, of contraction) to the full section F of the pipe. From § 515 we know that the loss of head due to the short pipe is $h_r = \zeta_E \frac{v_m^2}{2g}$ (for $\alpha = 90^\circ$), in which

$\zeta_E = 0.505$; while from Borda's Formula, § 523, we have also $\zeta_E = \left[\frac{F}{CF} - 1 \right]^2$. Equating these, we find the coefficient of internal contraction at m' to be

$$C = \frac{1}{1 + \sqrt{\zeta_E}} = \frac{1}{1 + \sqrt{.505}} = 0.584,$$

or about 0.60 (compare with $C = .64$ for thin-plate contraction, § 495). It is probably somewhat larger than this (.584), since a small part of the loss of head, h_r , is due to friction at the corners and against the sides of the pipe.

By a method similar to that pursued in the example of § 523, we may show that unless h is less than 40 feet, about, the tube cannot be kept full, the discharge being as in Fig. 551. If the efflux takes place into a "partial vacuum," this limiting value of h is still smaller. Weisbach's experiments confirm these statements (but those in the C. U. Hyd. Lab. seem to indicate that the limiting value for h in the first case is about 50 ft.).

525. Diaphragm in a Cylindrical Pipe.—Fig. 579. The diaphragm being of "thin plate," let the circular opening in it (concentric with the pipe) have an area = F , while the sectional area of pipe = F_1 . Beyond F , the stream contracts to a section of area = $CF = F_1$, in enlarging

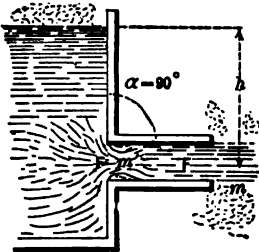

FIG. 578.



FIG. 579.

from which to fill the section F_2 , of pipe, a loss of head occurs which by Borda's Formula, § 523, is

$$h_r = \zeta \frac{v_2^2}{2g} = \left(\frac{F_2}{F_1} - 1 \right)^2 \frac{v_2^2}{2g},$$

where v_2 is the velocity in the pipe (*supposed full*). Of course F_1 (or CF) depends on F ; but since experiments are necessary in any event, it is just as well to give the values of ζ itself, as determined by Weisbach's experiments, viz.:

For $\frac{F}{F_2} = .10$.20	.30	.40	.50	.60	.70	.80	.90	1.00
$\zeta = 226.$	48.	17.5	7.8	3.7	1.8	.8	.3	.06	0.00

By internal lateral filling, Fig. 580, the change of section may be made gradual and eddying prevented; and then but little loss of head (and therefore little loss of energy) occurs, besides the slight amount due to skin-friction along this small surface. On p. 467 of the article *Hydromechanics* in the *Encyclopædia Britannica* may be found an account of experiments by Mr. Froude, illustrating this fact.

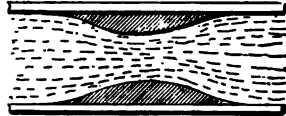

FIG. 580.

(526. "The Venturi Water-meter.")—The invention bearing this name was made by Mr. Olemens Herschel (see *Trans. Am. Soc. Civ. Engineers*, for November 1887), and may be described as a portion of pipe in which a gradual narrowing of section is immediately succeeded by a more gradual enlargement, as in Fig. 580; but the dimensions are more extreme. During the flow the piezometer-heights are observed at the three positions r , n , and m (see below), and the rate of discharge may be computed as follows: Referring to Fig. 580, let us denote by r the (up-stream) position where the narrowing of the pipe begins, and by m that where the enlargement ends, while n refers to the narrowest section. $F_m = F_r$.

Applying Bernoulli's Theorem to sections r and n , assuming

no loss of head between, we have, as the principle of the apparatus,

$$\frac{p_r}{\gamma} + \frac{v_r^2}{2g} = \frac{p_n}{\gamma} + \frac{v_n^2}{2g}; \quad \dots \quad (1)$$

whence, since $F_r v_r = F_n v_n$,

$$v_n = \sqrt{\frac{1}{1 - \left(\frac{F_n}{F_r}\right)^2}} \cdot \sqrt{2g \left(\frac{p_r}{\gamma} - \frac{p_n}{\gamma}\right)} = \phi \sqrt{2g \left(\frac{p_r}{\gamma} - \frac{p_n}{\gamma}\right)}, \quad (2)$$

in which ϕ represents the first radical factor. ϕ should differ but little from unity with $\frac{F_n}{F_r}$ small (and such was found to be the case by experiment). Its theoretical value is constant and greater than unity. In the actual use of the instrument the $\frac{p_r}{\gamma}$ and $\frac{p_n}{\gamma}$ are inferred from the observed piezometer-heights

y_r and y_n (since $\frac{p_r}{\gamma} = y_r + b$, and $\frac{p_n}{\gamma} = y_n + b$, b being = 34 ft.),

and then the quantity flowing per time-unit computed, from $Q = F_n v_n$, v_n having been obtained from eq. (2). This process gives a value of Q about four per cent in excess of the truth, according to the second set of experiments mentioned below, if $v_n = 35$ ft. per sec.; but only one per cent excess with $v_n = 5$ or 6 ft. per sec.

Experiments were made by Mr. Herschel on two meters of this kind, in each of which F_n was only one ninth of F_r , a ratio so extreme that the loss of head due to passage through the instrument is considerable. E.g., with the smaller apparatus, in which the diameter at n was 4 in., the loss of head between r and m was 10 or 11 ft., when the velocity through n was 50 ft. per sec., those at other velocities being roughly proportional to the square of the velocity. In the larger instrument d_n was 3 ft., and the loss of head between r and m was much more nearly proportional to the square of the velocity than in the smaller. (E.g., with $v_n = 34.56$ ft. per sec. the loss of head was 2.07 ft., while with $v_n = 16.96$ ft. per sec. it

was 0.49 ft.) The angle of divergence was much smaller in these meters than that in Fig. 580.

527. Sudden Diminution of Cross-section, Square Edges.—Fig. 581. Here, again, the resistance is due to the sudden enlargement from the contracted section to the full section F_2 of the small pipe, so that in the loss of head, by Borda's formula,



FIG. 581.

$$h_r = \zeta \frac{v_2^2}{2g} = \left[\frac{F_2}{F_1} - 1 \right]^2 \frac{v_1^2}{2g}, \dots \dots (1)$$

the coefficient

$$\zeta = \left(\frac{F_2}{F_1} - 1 \right)^2 = \left(\frac{F_2}{CF_1} - 1 \right)^2 = \left(\frac{1}{C} - 1 \right)^2 \dots \dots (2)$$

depends on the coefficient of contraction C ; but this latter is influenced by the ratio of F_2 to F_0 , the sectional area of the larger pipe, C being about .60 when F_2 is very large (i.e., when the small pipe issues directly from a large reservoir so that $F_2 : F_0$ practically = 0). For other values of this ratio Weisbach gives the following table for C , from his own experiments:

For $F_2 : F_0 =$.10	.20	.30	.40	.50	.60	.70	.80	.90	1.00
$C =$.624	.632	.648	.659	.681	.712	.755	.818	.892	1.00

C being found, we compute ζ from eq. (2) for use in eq. (1).

528. Elbows.—The internal disturbance caused by an elbow, Fig. 582 (pipe full, both sides of elbow), occasions a loss of head



FIG. 582.

$$h_r = \zeta \frac{v^2}{2g}, \dots \dots (1)$$

in which, according to Weisbach's experiments with tubes 3 centims., i.e. 1.2 in., in diameter, we may put

For $\alpha = 20^\circ$	40°	60°	80°	90°	100°	110°	120°	130°	140°
$\zeta = .046$.139	.364	.740	.984	1.26	1.556	1.86	2.16	2.43

computed from the empirical formula ;

$$\zeta = .9457 \sin^2 \frac{1}{2}\alpha + 2.047 \sin^4 \frac{1}{2}\alpha ;$$

v is the velocity in pipe ; α as in figure. For larger pipes ζ would probably be somewhat smaller ; and *vice versa*.

If the elbow is immediately succeeded by another in the same plane and turning the same way, Fig. 583, the loss of head is not materially increased, since the eddying takes place chiefly in the further branch of the second elbow ; but if it turns in the reverse direction, Fig. 584, but still in the same

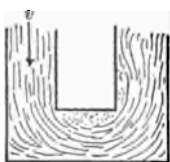

FIG. 583.

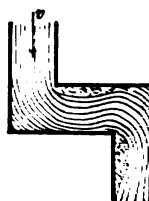

FIG. 584.

plane, the total loss of head is double that of one elbow ; while if the plane of the second is \perp to that of the first, the total loss of head is $1\frac{1}{2}$ times that of one alone. (Weisbach.)

529. Bends in Pipes of Circular Section.—Fig. 585. Weis-

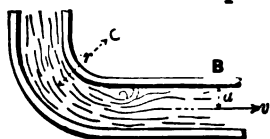

FIG. 585.

bach bases the following empirical formula for ζ , the coefficient of resistance of a quadrant bend in a pipe of circular section, on his own experiments and some of Dubuat's, viz. :

$$\zeta = 0.131 + 1.847 \left(\frac{a}{r}\right)^2, \dots \dots (1)$$

for use in

$$h_r = \zeta \frac{v^2}{2g}, \dots \dots (2)$$

where a = radius of pipe, r = radius of bend (to centre of pipe), and v = velocity in pipe ; h_r = loss of head due to bend.

It is understood that the portion *BC* of the pipe is kept full by the flow; which, however, may not be practicable unless *BC* is more than three or four times as long as wide, and is full at the outset. A semicircular bend occasions about the same loss of head as a quadrant bend, but two quadrants forming a reverse curve in the same plane, Fig. 586, occasion a double loss. By enlarging the pipe at the bend, or providing internal thin partitions parallel to the sides, the loss of head may be considerably diminished. Weisbach gives the following table computed from eq. (1), but does not state the absolute size of the pipes.



Fig. 586.

For $\frac{a}{r} =$.10	.20	.30	.40	.50	.60	.70	.80	.90	1.0
$\zeta =$.181	.188	.158	.206	.294	.440	.661	.977	1.40	1.98

Accounts of many of Weisbach's hydraulic experiments are contained in the *Civilingénieur*, vols. IX, X, and XI.

529a. Common Pipe-elbows.—Prof. L. F. Bellinger of Norwich University, Vermont, conducted a set of experiments in 1887, when a student at Cornell, on the loss of head occasioned by a common elbow (for wrought-iron pipe), whose longitudinal section is shown in Fig. 586a. The elbow served to connect at right angles two wrought-iron pipes having an internal diameter of 0.482 in.

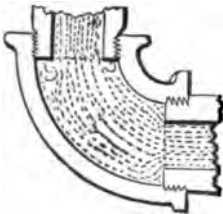

Fig. 586a.

The internal diameter of the short bend or elbow was $\frac{5}{8}$ in., and the radius of its curved circular axis (a quadrant) was $\frac{3}{4}$ in. Its internal surface was that of an ordinary rough casting.

A straight pipe of the same character and size and 14 feet long was first used, and the loss of head due to skin-friction (the only loss of head in that case) carefully determined for a range of velocities from 2 to 20 ft. per sec.

Two lengths of similar pipe were then joined by the elbow

mentioned, forming a total length of 14 feet, and the total loss of head again determined through the same range of velocities. By subtraction, the loss of head due to the elbow was then easily found for each velocity, and assuming the form

$$h = \zeta \frac{v^2}{2g} \dots \dots \dots (1)$$

for the loss of head, ζ was computed in each case.

From Fig. 586a it is seen that the stream meets with a sudden enlargement and a sudden diminution, of section, as well as with the short bend; so that the disturbance is of a rather complex nature.

The principal results of Prof. Bellinger's experiments, after the adjustment of the observed quantities by "least squares," were found capable of being represented fairly well by the formula

$$\zeta = 0.621 + [2^n - 1] \times 0.0376, \dots \dots (2)$$

where $n = [\text{veloc. in pipe in ft. per sec.}] \div 5$. The following table was computed from eq. (2) (where v is in ft. per second):

$v =$	2	4	6	8	10	12	14	16	18	20
$\zeta =$.633	.649	.670	.697	.734	.782	.845	.929	1.039	1.185

530. Valve-gates and Throttle-valves in Cylindrical Pipes.— Adopting, as usual, the form

$$h_r = \zeta \frac{v^2}{2g}, \dots \dots \dots (1)$$

for the loss of head due to a *valve-gate*, Fig. 587, or for a

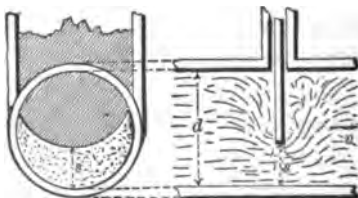

FIG. 587.

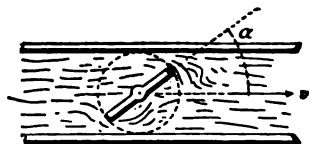

FIG. 588.

throttle-valve, Fig. 588, each in a definite position, Weisbach's

experiments furnish us with a range of values of ζ in the case of these obstacles in a cylindrical pipe 1.6 inches in diameter, as follows (for meaning of s , d , and α , see figures. v is the velocity in the full section of pipe, running full on both sides.)

Valve-gate.		Throttle-valve.	
$\frac{s}{d}$	ζ	α	ζ
1.0	.00	5°	.24
		10°	.52
		15°	.90
$\frac{1}{2}$.07	20°	1.54
		25°	2.51
$\frac{1}{3}$.26	30°	3.91
		35°	6.23
$\frac{1}{4}$.81	40°	10.8
		45°	18.7
$\frac{1}{5}$	2.06	50°	32.6
		55°	58.8
$\frac{1}{6}$	5.52	60°	118.0
		65°	256.0
$\frac{1}{7}$	97.8	70°	751.

531. Examples involving Divers Losses of Head.—We here suppose, as before, that the pipes are full during the flow. Practically, provision must be made for the escape of the air which collects at the high points. If this air is at a tension greater than one atmosphere, automatic air-valves will serve to provide for its escape; if less than one atmosphere, an air-pump can be used, as in the case of a siphon used at the Kansas City Water Works. (See p. 346 of the *Engineering News* for November 1887.)

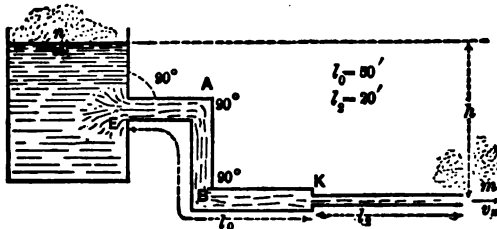

FIG. 589.

EXAMPLE 1.—Fig. 589. What head, = h , will be required to deliver $\frac{1}{2}$ U. S. gallon (i.e. 231 cubic inches) per second

through the continuous line of pipe in the figure, containing two sizes of cylindrical pipe ($d_o = 3$ in., and $d_s = 1$ in.), and two 90° elbows in the larger. The flow is into the air at m , the jet being 1 in. in diameter, like the pipe. At E , $\alpha = 90^\circ$, and the corners are not rounded; at K , also, corners not rounded. Use the ft.-lb.-sec. system of units in which $g = 32.2$.

Since $Q = \frac{1}{2}$ gal. $= \frac{1}{2} \cdot \frac{2.31}{1.732} = .0668$ cub. ft. per sec., and therefore the velocity of the jet

$$v_m = v_s = Q \div \frac{1}{4}\pi\left(\frac{1}{2}\right)^2 = 12.25 \text{ ft. per sec.};$$

hence the velocity in the large pipe is to be $v_o = \left(\frac{1}{2}\right)^2 v_s = 1.36$ ft. per sec. From Bernoulli's Theorem, we have, with m as datum plane,

$$\begin{aligned} \frac{v_m^2}{2g} + b + 0 = 0 + b + h - \zeta_E \frac{v_o^2}{2g} - 4f_o \frac{l_o}{d_o} \cdot \frac{v_o^2}{2g} \\ - 2\zeta_{el} \cdot \frac{v_o^2}{2g} - \zeta_K \frac{v_o^2}{2g} - 4f_s \frac{l_s}{d_s} \cdot \frac{v_s^2}{2g}, \end{aligned}$$

involving six separate losses of head, for each of which there is no difficulty in finding the proper ζ or f , since the velocities and dimensions are all known, by consulting preceding paragraphs. (Clean iron pipe.)

From § 515, table, for $\alpha = 90^\circ$ we have . . . $\zeta_E = 0.505$

“ § 517, for $d_o = 3$ in., and $v_o = 1.36$ ft. per sec., $f_o = .00725$

“ “ “ $d_s = 1$ in., and $v_s = 12.25$ “ “ $f_s = .00613$

“ § 528 (elbows), for $\alpha = 90^\circ$ $\zeta_{el} = 0.984$

“ § 527, for sudden diminution at K we have

[since $F_s \div F_o = 1^2 \div 3^2 = 0.111$, $\therefore C = 0.625$]

$$\zeta_K = \left(\frac{1}{.625} - 1\right)^2 = 0.360.$$

Solving the above equation for h , then, and substituting above numerical values (in ft.-lb.-sec.-system), we have (noting that $v_m = v_s$, and $v_o = \frac{1}{2}v_s$)

$$\begin{aligned} h = \frac{(12.25)^2}{64.4} \left[1 + \left(\frac{1}{2}\right)^2 \left(.505 + \frac{4 \times .00725 \times 50}{\frac{1}{2}} + 2 \times .984 \right) \right. \\ \left. + .360 + \frac{4 \times .00613 \times 20}{\frac{1}{2}} \right]; \end{aligned}$$

i.e.,

$$h = \frac{(12.25)^2}{64.4} \left[1 + (.00623 + .07160 + .0243) + (.360 + 5.8848) \right];$$

$$\therefore h = 2.323 \times 7.3469 = 17.09 \text{ ft.} \text{---} Ans.$$

It is here noticeable how small are the losses of head in the large pipe, the principal reason of this being that the *velocity* in it is so small ($v_1 =$ only 1.36 ft. per sec.), and that in general losses of head depend on the *square* of the velocity (nearly).

In other words, the large pipe approximates to being a reservoir in itself.

With no resistances a head $h = v_m^2 \div 2g = 2.32$ ft. would be sufficient.

EXAMPLE 2.—Fig. 590. With the valve-gate V half raised (i.e., $s = \frac{1}{2}d$ in Fig. 587), required the volume delivered per second through the *clean* pipe here shown. The jet issues

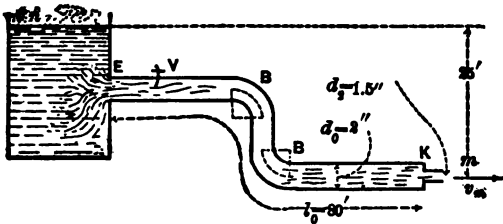

FIG. 590.

from a short straight pipe, or nozzle (of diameter $d_2 = 1\frac{1}{2}$ in.) inserted in the end of the larger pipe, with the inner corners *not rounded*. Dimensions as in figure. Radius of each bend = $r = 2$ in. The velocity v_m of the jet in the air = velocity v_2 in the small pipe; hence the loss of head at K is

$$\zeta_K \frac{v_2^2}{2g}, = \zeta_K \frac{v_m^2}{2g}.$$

Now v_m is unknown, as yet; but v_1 , the velocity in the large pipe, is = $v_m \left[\frac{(\frac{1}{2})^2}{2^2} \right]$; i.e., $v_1 = \frac{1}{16}v_m$. From Bernoulli's The-

orem (m as datum level) we obtain, after transposition,

$$h = \frac{v_m^2}{2g} + \zeta_x \frac{v_o^2}{2g} + \zeta_v \frac{v_o^2}{2g} + 2\zeta_B \frac{v_o^2}{2g} + 4f_o \frac{l_o v_o^2}{d_o 2g} + \zeta_x \frac{v_m^2}{2g}. \quad (1)$$

Of the coefficients concerned, f_o alone depends on the unknown velocity v_o . For the present [first approximation],

- put $f_o = .006$
- From § 515, with $\alpha = 90^\circ$, $\zeta_x = .505$
- From § 517, valve-gate with $s = \frac{1}{4}d$, $\zeta_v = 2.06$
- From § 529, with $a : r = 0.5$, $\zeta_B = 0.294$
- While at K , from § 527, having

$$(F_o : F_m) = (\frac{1}{2})^2 : 2^2 = \frac{1}{16} = 0.562;$$

we find from table, $C = 0.700$

and $\therefore \zeta_x = \left(\frac{1}{.700} - 1\right)^2 = (0.428)^2$ i.e., $\zeta_x = 0.183$

Substituting in eq. (1) above, with $v_o^2 = (\frac{1}{16})^2 v_m^2$, we have

$$v_m = \sqrt{\frac{1}{1 + \frac{81}{256} \left[\zeta_x + \zeta_v + 2\zeta_B + 4f_o \frac{l_o}{d_o} \right] + \zeta_x}} \sqrt{2gh}, \quad (2)$$

in which the first radical, an abstract number, might be called a *coefficient of velocity*, ϕ , for the whole delivery pipe; and also, since in this case $Q_o = F_m v_m = F_o v_o$, may be written $Q = \mu F_o \sqrt{2gh}$, it may be named a *coefficient of efflux*, μ .

Hence

$$v_m = \sqrt{\frac{1}{1 + \frac{81}{256} \left[.505 + 2.06 + 2 \times .294 + \frac{4 \times .006 \times 80}{\frac{1}{4}} \right] + .183}} \sqrt{2 \times 32.2 \times 25};$$

$\therefore v_m = 0.421 \sqrt{2gh} = 0.421 \sqrt{2 \times 32.2 \times 25} = 16.89$ ft. per sec.

(The .421 might be called a coefficient of velocity.) The volume delivered per second is

$$Q = \frac{1}{4} \pi d_o^2 v_m = \frac{1}{4} \pi \left(\frac{1}{2}\right)^2 16.89 = .207$$
 cub. ft. per sec.

(As the section of the jet $F_m = F_o$, that of the short pipe or nozzle, we might also say that $.421 = \mu =$ *coefficient of efflux*, for we may write $Q = \mu F_o \sqrt{2gh}$, whence $\mu = .421$.)

532. Siphons.—In Fig. 532, § 490, the portion HN_1O is above the level, BC , of the surface of the water in the head reservoir BL , and yet under proper conditions a steady flow can be maintained with all parts of the pipe full of water, including HN_1O . If the atmosphere exerted no pressure, this would be impossible; but its average tension of 14.7 lbs. per sq. inch is equivalent to an additional depth of nearly 34 feet of water placed upon BC . With no flow, or a very small velocity, the pipe may be kept full if N_1 is not more than 33 or 34 feet above BC ; but the greater v_1 , the velocity of flow at N_1 , and the greater and more numerous the losses of head between L and N_1 , the less must be the height of N_1 above BC for a steady flow.

The analytical criterion as to whether a flow can be maintained or not, supposing the pipe completely filled at the outset, is that the internal pressure must be > 0 at all parts of the pipe. If on the supposition of a flow through a pipe of given design the pressure p is found < 0 , i.e. negative, at any point [N_1 being the important section for test] the supposition is inadmissible, and the design must be altered.

For example, Fig. 532, suppose LN_1N_1 to be a long pipe of uniform section (diameter = d , and length = l), and that under the assumption of filled sections we have computed v_1 , the velocity of the jet at N_1 ; i.e.,

$$v_1 = \sqrt{\frac{1}{1 + \zeta_L + 4f \frac{l}{d}}} \sqrt{2gh} \dots \dots (1)$$

To test the supposition, apply Bernoulli's Theorem to the surface BC and the point N_1 , where the pressure is p_1 , velocity $v_1 (= v_2$, since we have supposed a uniform section for whole pipe), and height above $BC = h_1$. Also, let length of pipe $LN_1HN_1 = l_1$. Whence we have

$$\frac{v_1^2}{2g} + \frac{p_1}{\gamma} + h_1 = 0 + \frac{p_a}{\gamma} (= b) + 0 - \zeta_L \frac{v_1^2}{2g} - 4f \frac{l_1}{d} \frac{v_1^2}{2g} \dots (2)$$

[BC being datum plane.]

Solving for $\frac{p_1}{\gamma}$, we have

$$\frac{p_1}{\gamma} = 34 \text{ feet} - \left[h_1 + \frac{v_1^2}{2g} \left(1 + \zeta_L + 4f \frac{l_1}{d} \right) \right]. \dots (3)$$

We note, then, that for p_1 to be > 0 ,

$$h_1 \text{ must be } < \left[34 \text{ feet} - \frac{v_1^2}{2g} - \zeta_L \frac{v_1^2}{2g} - 4f \frac{l_1}{d} \frac{v_1^2}{2g} \right]. \dots (4)$$

In the practical working of a siphon it is found that atmospheric air, previously dissolved in the water, gradually collects at N_1 , the highest point, during the flow and finally, if not removed, causes the latter to cease. See reference below.

One device for removing the air consists in first allowing it to collect in a chamber in communication with the pipe beneath. This communication is closed by a stop-cock after the water in it has been completely displaced by air. Another stop-cock, above, being now opened, water is poured in to replace the air, which now escapes. Then the upper stop-cock is shut and the lower one opened. The same operation is again necessary, after some hours.

On p. 346 of the *Engineering News* of November 1887 may be found an account of a siphon which has been employed since 1875 in connection with the water-works at Kansas City. It is 1350 ft. long, and transmits water from the river to the artificial "well" from which the pumping engines draw their supply. At the highest point, which is 16 ft. above low-water level of the river, is placed a "vacuum chamber" in which the air collects under a low tension corresponding to the height, and a pump is kept constantly at work to remove the air and prevent the "breaking" of the (partial) vacuum. The diameter of the pipe is 24 in., and the extremity in the "well" dips 5 ft. below the level of low water. See Trautwine's Pocket-book, for an account of Maj. Crozet's Siphon.

532a. **Branching Pipes.**—If the flow of water in a pipe is caused to divide and pass into two others having a common

junction with the first, or *vice versa*; or if lateral pipes lead out of a main pipe, the problem presented may be very complicated. As a comparatively simple instance, let us suppose that a pipe of diameter d and length l leads out of a reservoir, and at its extremity is joined to two others of diameters d_1 and d_2 , and lengths l_1 and l_2 , respectively, and that the further extremities of the latter discharge into the air without nozzles under heads h_1 and h_2 , below the reservoir surface. Call these two pipes Nos. 1 and 2. That is, the system forms a Y in plan.

Assuming that all entrances and junctions are smoothly rounded, so that all loss of head is due to skin-friction, it is required to find the three velocities of flow, v , v_1 , and v_2 , in the respective pipes. First applying Bernoulli's Theorem to a stream-line from the reservoir surface through the main pipe to the jet at the discharging end of pipe No. 1, we have

$$\frac{v_1^2}{2g} = h_1 - 4f \frac{l}{d} \cdot \frac{v^2}{2g} - 4f \frac{l_1}{d_1} \cdot \frac{v_1^2}{2g}; \dots (1)$$

and similarly, dealing with a stream-line through the main pipe and No. 2,

$$\frac{v_2^2}{2g} = h_2 - 4f \frac{l}{d} \cdot \frac{v^2}{2g} - 4f \frac{l_2}{d_2} \cdot \frac{v_2^2}{2g}; \dots (2)$$

while the equation of continuity for this case is

$$\frac{1}{4} \pi d^2 v = \frac{1}{4} \pi d_1^2 v_1 + \frac{1}{4} \pi d_2^2 v_2. \dots (3)$$

From these three equations, assuming f the same in all pipes as a first approximation, we can find the three velocities (best by numerical trial, perhaps); and then the volume of discharge of the system per unit of time

$$Q = \frac{1}{4} \pi d^2 v. \dots (4)$$

533. Time of Emptying Vertical Prismatic Vessels (or Inclined Prisms if Bottom is Horizontal) under Variable Head.

CASE I. *Through an orifice or short pipe in the bottom and opening into the air.*—Fig. 591. As the upper free surface,

of area = F' , sinks, F' remains constant. Let z = head of water at any stage of the emptying; it = z_0 at the outset, and = 0 when the vessel is empty. At any instant, Q , the rate of discharge (= volume per time-unit) depends on z and is

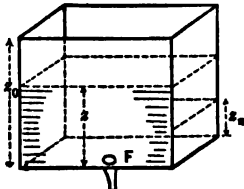

FIG. 501.

$$Q = \mu F \sqrt{2gz}, \dots (1)$$

where μ = coefficient of efflux = ϕC = coefficient of velocity \times coefficient of contraction [see § 495, eq. (3)]. We here suppose F' so large compared with F , the area of the orifice, that the free surface of the water in the vessel does not acquire any notable velocity at any stage, and that hence the rate of efflux is the same at any instant, as for a steady flow with head = z and a zero velocity in the free surface. μ is considered constant. From (1) we have

$$dV = (\text{vol. discharged in time } dt) = Qdt = \mu F \sqrt{2gz} dt. \dots (2)$$

But this is also equal to the volume of the horizontal lamina, $F' dz$, through which the free surface has sunk in the same time dt .

$$\therefore -F' dz = \mu F \sqrt{2g} z^{\frac{1}{2}} dt; \therefore dt = \frac{-F'}{\mu F \sqrt{2g}} z^{-\frac{1}{2}} dz. \dots (3)$$

We have written *minus* $F' dz$ because, dt being an increment, dz is a decrement. To reduce the depth from z_0 (at the start, time = t = zero) to z_n , demands a time

$$\int_0^n t = - \frac{F'}{\mu F \sqrt{2g}} \int_{z_0}^{z_n} z^{-\frac{1}{2}} dz = \frac{2F'}{\mu F \sqrt{2g}} [z_0^{\frac{1}{2}} - z_n^{\frac{1}{2}}]; (4)$$

whence, by putting $z_n = 0$, we have the time necessary to empty the whole prism

$$\int_0^n t = \frac{2F' z_0^{\frac{1}{2}}}{\mu F \sqrt{2g}} = \frac{2F' z_0}{\mu F \sqrt{2gz_0}} = \frac{2 \times \text{volume of vessel}}{\text{initial rate of discharge}}; (5)$$

that is, to empty the vessel requires *double the time* of discharging the same amount of water if the vessel had been kept full (at constant head = z , = altitude of prism).

To fill the same vessel through an orifice in the bottom, the flow through which is supplied from a body of water of infinite extent horizontally, as with the (single) canal lock of Fig. 592, will obviously require the same time as given in eq. (5) above, since the effective head z diminishes from z , to 0, according to the same law.

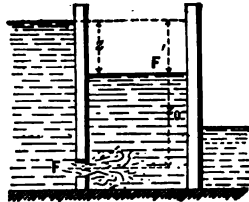

FIG. 592.

EXAMPLE.—What time will be needed to empty a parallelepipedal tank (Fig. 591) 4 ft. by 5 ft. in horizontal section and 6 ft. deep, through a stop-cock in the bottom whose coefficient of efflux when fully open is known to be $\mu = 0.640$, and whose section of discharge is a circle of diameter = $\frac{1}{4}$ in.? From given dimensions $F' = 4 \times 5 = 20$ sq. ft., while $z_0 = 6$ ft. Hence from eq. (5) (ft.-lb.-sec.)

$$\left. \begin{array}{l} \text{time of} \\ \text{emptying} \end{array} \right\} = \frac{2 \times 20 \times \sqrt{6}}{0.64 \times \frac{1}{4} \pi \left(\frac{1}{4}\right)^2 \sqrt{2} \times 32.2} = \left\{ \begin{array}{l} 13980 \text{ seconds} \\ = 3 \text{ hours } 53 \text{ min. } 0 \text{ sec.} \end{array} \right.$$

CASE II. *Two communicating prismatic vessels. Required the time for the water to come to a common level ON, Fig. 593, efflux taking place through a small orifice, of area = F , under water. At any instant the rate of discharge is*

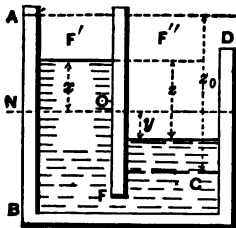

FIG. 593.

$$Q = \mu F \sqrt{2gz},$$

as before. z = difference of level. Now if F' and F'' are the horizontal sectional areas of the two prismatic vessels (axes vertical) we have $F'x = F''y$, and hence z , which = $x + y$, = $x + (F' \div F'')x$;

$$\therefore x = \frac{z}{1 + \frac{F'}{F''}}, \text{ and } dx = \frac{dz}{1 + \frac{F'}{F''}}.$$

As before, we have

$$-F'dx = \mu F \sqrt{2g} z^{\frac{1}{2}} dt, \text{ or } dt = -\frac{F'F''}{F'+F''} \frac{z^{-\frac{1}{2}} dz}{\mu F \sqrt{2g}}$$

Hence, integrating, the time for the *difference* of level to change from z_0 to z_n

$$= \frac{2F'F''}{F'+F''} \cdot \frac{z_0^{\frac{1}{2}} - z_n^{\frac{1}{2}}}{\mu F \sqrt{2g}}, \dots \dots \dots (6)$$

and by making $z_n = 0$ in (6), we have the

$$\text{time of coming to a common level} = \frac{2F'F''}{F'+F''} \cdot \frac{1}{\mu F} \sqrt{\frac{z_0}{2g}} \quad (7)$$

ALGEBRAIC EXAMPLE.—In the double lock in Fig. 594, let L' be full, while in L'' the water stands at a level MN the same as that of the tail-water. F' and F'' are the

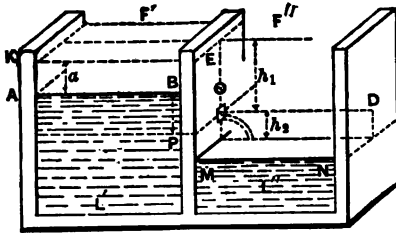

FIG. 594.

horizontal sectional areas of the prismatic locks. Let the orifice, O , between them, be at a depth $= h_1$ below the initial level KE of L' , and a height $= h_2$ above that, MN , of L'' .

The orifice at O , area $= F$, being opened, efflux from L' begins *into the air*, and the level of L'' is gradually raised from MN to OD , while that of L' sinks from KE to AB a distance $= a$, computed from the relation $\text{vol. } F'a = \text{vol. } F''h_2$, and the time occupied is [eq. (4)]

$$t_1 = \frac{2F'}{\mu F \sqrt{2g}} [\sqrt{h_1} - \sqrt{h_1 - a}] \dots \dots \dots (8)$$

As soon as O is submerged, efflux takes place under water, and we have an instance of Case II. Hence the time of reaching a common level (after submersion of O) (see eq. 7) is

$$t_2 = \frac{2F'F''}{\mu F(F'+F'')} \sqrt{\frac{h_2 - a}{2g}}, \dots \dots \dots (9)$$

and the total time is $= t_1 + t_2$, with $a = F''h_2 \div F'$.

CASE III. *Emptying a vertical prismatic vessel through a rectangular "notch" in the side, or overfall.*—Fig. 595. As before, let even the initial area ($= z_0 b$) of the notch be small compared with the horizontal area F' of tank. Let z = depth of lower sill of notch below level of tank surface at any instant, and b = width of notch. Then, at any instant (see eq. 10, § 504),

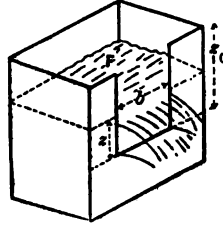

FIG. 595.

$$\text{Rate of disch. (vol.)} = Q = \frac{3}{2} \mu_c b z \sqrt{2gz} = \frac{3}{2} \mu b \sqrt{2g} z^{3/2}.$$

$$\therefore \text{vol. of disch. in } dt = \frac{3}{2} \mu b \sqrt{2g} z^{3/2} dt,$$

and putting this = $-F' dz$ = vol. of water lost by the tank in time dt , we have

$$dt = -\frac{3}{2} \frac{F'}{\mu b \sqrt{2g}} z^{-1/2} dz;$$

whence

$$\int_0^t dt = -\frac{3}{2} \frac{F'}{\mu b \sqrt{2g}} \int_{z_0}^{z_n} z^{-1/2} dz = -\frac{3}{2} \frac{F'}{\mu b \sqrt{2g}} \left[\frac{z^{-1/2}}{-1/2} \right]_0^{z_n};$$

i.e.,

$$\int_0^t dt = \frac{3F'}{\mu b \sqrt{2g}} \left[\frac{1}{\sqrt{z_n}} - \frac{1}{\sqrt{z_0}} \right], \dots \dots (10)$$

as the time in which the tank surface sinks from a height z_0 above sill to a height z_n above sill. If we inquire the time t' for the water to sink to the level of the sill of the notch we put $z_n =$ zero, whence $t' =$ infinity. As explanatory of this result, note that as z diminishes not only does the velocity of flow diminish, but the available area of efflux ($= zb$) also grows less, whereas in Cases I and II the orifice of efflux remained of constant area = F' .

Eq. (10) is applicable to the waste-weir of a large reservoir or pond.

534. **Time of Emptying Vessels of Variable Horizontal Sections.**—Considering regular geometrical forms first, let us take

CASE I. *Wedge-shaped vessel, edge horizontal and underneath, orifice F in the edge, so that z , the variable head, is always the altitude of a triangle similar to the section ABC of the body of water when efflux begins. At any instant during the efflux the area, S , of the free surface, variable here, takes the place of F' in eq. (3) of § 533, whence we have,*

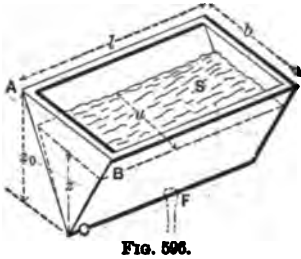

$$\text{for any case of variable free surface, } dt = \frac{-Sz^{-1}dz}{\mu F \sqrt{2g}}. \quad (11)$$

In the present case $S = ul$, and from similar triangles

$$u : z :: b : z_0;$$

whence

$$S = blz \div z_0,$$

and

$$dt = \frac{-blz^{-1}dz}{\mu F z_0 \sqrt{2g}};$$

$$\therefore \int_0^{z_0} t = \frac{bl}{\mu F z_0 \sqrt{2g}} \int_{z_n}^{z_0} z^{-1} dz = \frac{\frac{1}{2}bl}{\mu F z_0 \sqrt{2g}} [z_0^{-1} - z_n^{-1}], \quad (12)$$

and hence the time of emptying the whole wedge, putting $z_n = 0$, is

$$t_0 = \frac{4}{3} \cdot \frac{\frac{1}{2}blz_0}{\mu F \sqrt{2gz_0}} = \frac{4}{3} \cdot \frac{\text{Vol. of wedge}}{\text{initial rate of discharge}}; \quad (13)$$

i.e., $\frac{4}{3}$ as long as to discharge the same volume of water under a constant head $= z_0$. This is equally true if the ends of the wedge are *oblique*, so long as they are parallel.

CASE II. *Right segment of paraboloid of revolution.—Fig. 597. Axis vertical. Orifice at vertex. Here the variable free surface has at any instant an area, $= S, = \pi u^2$, u being the radius of the circle and variable. From a property of the parabola*

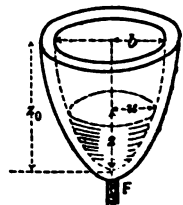

$$u^2 : b^2 :: z : z_0; \quad \therefore S = \pi b^2 z \div z_0,$$

and hence, from eq. (11),

$$dt = \frac{-\pi b^2 z dz}{\mu F z_0 \sqrt{2g}}$$

$$\therefore \int_0^{z_n} dt = \frac{\pi b^2}{\mu F z_0 \sqrt{2g}} \int_{z_n}^{z_0} z dz = \frac{2}{3} \frac{\pi b^2}{\mu F z_0 \sqrt{2g}} [z_0^3 - z_n^3];$$

whence, putting $z_n = 0$, we have the time of emptying the whole vessel

$$t_0 = \frac{4}{3} \frac{\pi b^2 \frac{1}{2} z_0}{\mu F \sqrt{2g z_0}} = \frac{4}{3} \cdot \frac{\text{total vol.}}{\text{initial rate of disch.}} \quad (14)$$

same result as for the wedge, in Case I; in fact, it applies to any vessel in which the areas of horizontal sections vary directly with their heights above the orifice.

CASE III. Any pyramid or cone; vertex down; small orifice in vertex.—Fig. 598. Let area of the base = S_0 , at upper edge of vessel. At any stage of the flow S = area of base of pyramid of water. From similar pyramids

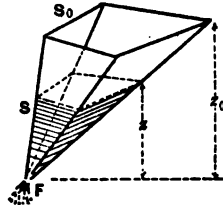

FIG. 598.

$$S_0 : S :: z_0^2 : z^2; \therefore S = \frac{S_0}{z_0^2} z^2,$$

and [eq. (11)]

$$dt = -\frac{S_0}{z_0^2} \frac{1}{\mu F \sqrt{2g}} z dz,$$

whence ($z_n = 0$) the time of emptying the whole vessel is

$$t_0 = \frac{S_0}{\mu F z_0^2 \sqrt{2g}} \int_0^{z_0} z dz = \frac{2}{5} \frac{S_0 z_0^3}{\mu F z_0^2 \sqrt{2g}};$$

or,
$$t_0 = \frac{6}{5} \cdot \frac{\text{Total volume}}{\text{initial rate of disch.}} \dots \dots (15)$$

CASE IV. Sphere.—Similarly, we may show that to empty

a sphere, of radius = r , through a small orifice, of area = F , in lowest part, the necessary time is

$$t_0 = \frac{16}{15} \cdot \frac{\pi r^3}{\mu F \sqrt{gr}} = \frac{8}{5} \cdot \frac{\text{Vol.}}{\text{init. rate of disch.}}$$

535. Time of Emptying an Obelisk-shaped Vessel.—(An obelisk may be defined as a solid of six plane faces, two of which are rectangles in parallel planes and with sides respectively parallel, the others trapezoids; a frustum of a pyramid is a particular case.)

A volume of this shape is of common occurrence; see Fig. 599. Let the altitude = h , the two rectangular faces being horizontal, with dimensions as in figure. By drawing through

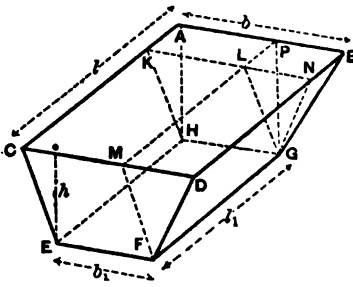

FIG. 599.

parallel to EC , to cut the upper base, we form a rectangle $KLMC$ equal to the lower base. Produce ML to P and KL to N , and join PG and NG . We have now subdivided the solid into a parallelepiped $KLMC-EHGF$, a pyramid $PBNL-G$, and

two wedges, viz. $APLK-HG$ and $LNDM-FG$, with their edges horizontal; and may obtain the time necessary to empty the whole obelisk-volume by adding the times which would be necessary to empty the individual component volumes, separately, through the same orifice or pipe in the bottom plane EG . These have been already determined in the preceding paragraphs. The dimensions of each component volume may be expressed in terms of those of the obelisk, and all have a common altitude = h .

Assuming the orifice to be in the bottom, or else that the discharging end of the pipe, if such is used, is in the plane of the bottom EG , we have as follows, F' being the area of discharge:

Time to empty the parallelopiped } . . . t₁ = $\frac{2b_1l_1}{\mu F \sqrt{2g}} \sqrt{h}$. (1)
separately would be (Case I, § 533)

Time to empty the two } t₂ = $\frac{2}{3} \cdot \frac{b_1(l-l_1) + l_1(b-b_1)}{\mu F \sqrt{2g}} \sqrt{h}$. (2)
wedges separately (Case I, § 534)

For the pyramid } . . . t₃ = $\frac{2}{5} \cdot \frac{(l-l_1)(b-b_1)}{\mu F \sqrt{2g}} \sqrt{h}$. . . (3)
(Case III, § 534)

Hence to empty the whole reservoir we have

$$t = t_1 + t_2 + t_3;$$

i.e.,

$$t = [3bl + 8b_1l_1 + 2bl_1 + 2b_1l] \frac{2 \sqrt{h}}{15 \mu F \sqrt{2g}} . . . (4)$$

EXAMPLE.—Let a reservoir of above form, and with $b = 50$ ft., $l = 60$ ft., $b_1 = 10$ ft., $l_1 = 20$ ft., and depth of water $h = 16$ ft., be emptied through a straight iron pipe, horizontal, and leaving the side of the reservoir *close to the bottom*, at an angle $\alpha = 36^\circ$ with the inner plane of side. The pipe is 80 ft. long and 4 inches in internal diameter; and of clean surface. The jet issues directly from this pipe into the air, and hence $F = \frac{1}{4}\pi(\frac{1}{2})^2$ sq. feet. To find μ , the “coefficient of efflux” ($= \phi$, the coefficient of velocity in this case, since there is no contraction at discharge orifice), we use eq. (4) (the first radical) of § 518, with f approx. = .006, and obtain

$$\mu = \phi = \sqrt{\frac{1}{1 + \zeta_r + 4f \frac{l}{d}}} = \sqrt{\frac{1}{1 + .896 + \frac{4 \times .006 \times 80}{\frac{1}{3}}}} = 0.361.$$

(N.B. Since the velocity in the pipe diminishes from a value

$$v = .361 \sqrt{2g \times 16} = 11.6 \text{ ft. per sec.}$$

at the beginning of the flow to $v =$ zero at the close, $f = .006$ is a reasonably approximate average with which to compute the average ϕ above; see § 517.

Hence from eq. (4) of this paragraph (ft.-lb.-sec. system)

$$t = \frac{[3 \times 50 \times 60 + 8 \times 10 \times 20 + 2(50 \times 20 + 10 \times 60)] 2 \sqrt{16}}{15 \times 0.361 \times \frac{\pi \left(\frac{1}{3}\right)^2}{4} \sqrt{2 \times 32.2}}$$

= 29110 sec. = 8 hrs. 5 min. } Probably within 2 or 3% of the truth.

536. Time of Emptying Reservoirs of Irregular Shape. Simpson's Rule.—From eq. (11), § 534, we have, for the time in which the free surface of water in a vessel of any shape whatever sinks through a vertical distance = dz ,

$$dt = \frac{-S z^{-\frac{1}{2}} dz}{\mu F \sqrt{2g}}, \text{ whence } \int_{z=z_0}^{z=z_n} \text{time} = \frac{1}{\mu F \sqrt{2g}} \int_{z_n}^{z_0} S z^{-\frac{1}{2}} dz, \dots (1)$$

where S is the variable area of the free surface at any instant, and z the head of water at the same instant, efflux proceeding through a small orifice (or extremity of pipe) of area = F . If S can be expressed in terms of z , we can integrate eq. (1) (i.e., provided that $S z^{-\frac{1}{2}}$ has a known anti-derivative); but if not, the vessel or reservoir being irregular in form, as in Fig. 600 (which shows a pond whose bottom has been accurately surveyed, so that we know the value of S for any stage of the emptying), we can still get an approximate

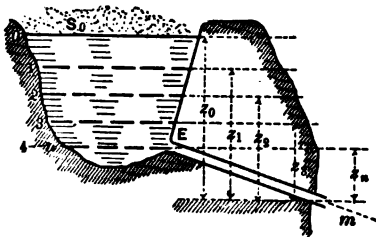

FIG. 600.

solution by using Simpson's Rule for approximate integration. Accordingly, if we inquire the time in which the surface will sink from 0 to the entrance E of the pipe in Fig. 600 (any point n ; at E . or short of that), we divide the vertical distance

from 0 to n (4 in this figure) into an even number of equal parts, and from the known form of the pond compute the area S corresponding to each point of division, calling them S_0, S_1, S_2, \dots etc. Then the required time is approximately

$$\int_0^n t = \frac{z_0 - z_n}{3\mu F \sqrt{2gn}} \left[\frac{S_0}{z_0^{\frac{5}{2}}} + 4 \left(\frac{S_1}{z_1^{\frac{5}{2}}} + \frac{S_2}{z_2^{\frac{5}{2}}} + \dots + \frac{S_{n-1}}{z_{n-1}^{\frac{5}{2}}} \right) + 2 \left(\frac{S_2}{z_2^{\frac{5}{2}}} + \frac{S_4}{z_4^{\frac{5}{2}}} + \dots + \frac{S_{n-2}}{z_{n-2}^{\frac{5}{2}}} \right) + \frac{S_n}{z_n^{\frac{5}{2}}} \right].$$

EXAMPLE.—Fig. 600. Suppose we have a pipe *Em* of the same design as in the example of § 535, and an initial head of $z_0 = 16$ ft., so that the same value of $\mu, = .361$, may be used. Let $z_n - z_0 = 8$ feet, and divide this interval (of 8 ft.) into four equal vertical spaces of 2 ft. each. If at the respective points of division we find from a previous survey that $S_0 = 400000$ sq. ft., $S_1 = 320000$ sq. ft., $S_2 = 270000$ sq. ft., $S_3 = 210000$ sq. ft., and $S_4 = 180000$ sq. ft.; while $n = 4, \mu = .361$, and the area $F = \frac{1}{4}\pi(\frac{1}{2})^2 = .0873$ sq. ft., we obtain (ft., lb., sec.)

$$\int_0^4 t = \frac{16 - 8}{0.361 \times .0873 \sqrt{2 \times 32.2} \times 3 \times 4} \left[\frac{400000}{\sqrt{16}} + \frac{4 \times 320000}{\sqrt{14}} + \frac{2 \times 270000}{\sqrt{12}} + \frac{4 \times 210000}{\sqrt{10}} + \frac{180000}{\sqrt{8}} \right] = 2444000 \text{ sec.} = 28^d \ 6^h \ 53^m \ 20^s$$

The volume discharged, *V*, may also be found by Simpson's Rule, thus: Since each infinitely small horizontal lamina has a volume

$$dV = -Sdz, \quad \therefore \int_0^n V = \int_n^0 Sdz,$$

or, approximately,

$$\int_0^n V = \frac{z_0 - z_n}{3n} \left[S_0 + 4S_1 + 2S_2 + 4S_3 + \dots + S_n \right].$$

Hence with $n = 4$ we have (ft., lb., sec.)

$$\int_0^4 V = \frac{16 - 8}{3 \times 4} \left[400000 + 4 \left\{ \frac{320000}{2} + 210000 \right\} + 2 \times 270000 + 180000 \right] = 2,160,000 \text{ cub. ft.}$$

537. Volume of Irregular Reservoir Determined by Observing Progress of Emptying.—Transforming eq. (11), § 534, we have

$$Sdz = -\mu F \sqrt{2g} z^{\frac{3}{2}} dt.$$

But Sdz is the infinitely small volume dV of water lost by the reservoir in the time dt , so that the volume of the reservoir between the initial and final (0 and n) positions of the horizontal free surface (at beginning and end of the time t_n) may be written

$$\left[V = \mu F \sqrt{2g} \int_0^{t_n} z^{\frac{3}{2}} dt. \dots \dots (1) \right.$$

This can be integrated approximately by Simpson's Rule, if the whole *time of emptying*, = t_n , be divided into an even

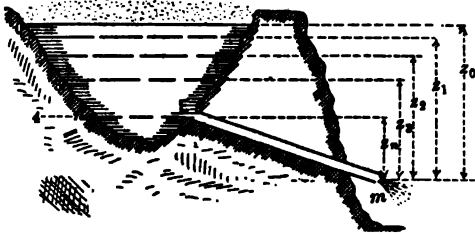

FIG. 601.

number of equal parts, and the values z_0, z_1, z_2 , etc., of the head of water noted at these *equal intervals of time* (not of vertical height). The corresponding surface planes will not

be equidistant, in general. Whence for the particular case when $n = 4$ (see Fig. 601)

$$\left[V = \frac{\mu F \sqrt{2g} (t_n - 0)}{3 \times 4} [z_0^{\frac{3}{2}} + 4(z_1^{\frac{3}{2}} + z_2^{\frac{3}{2}}) + 2z_3^{\frac{3}{2}} + z_4^{\frac{3}{2}}] \dots (2) \right.$$

CHAPTER VII.

HYDRODYNAMICS (*Continued*)—STEADY FLOW OF WATER IN OPEN CHANNELS.

538. **Nomenclature.**—Fig. 602. When water flows in an open channel, as in rivers, canals, mill-races, water-courses, ditches, etc., the bed and banks being rigid, the upper surface is free to conform in shape to the dynamic conditions of each case, which therefore regulate to that extent the shape of the cross-section.

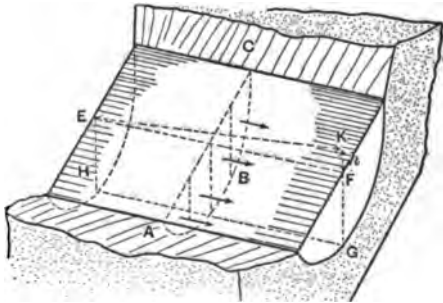

FIG. 602.

In the vertical transverse section AC in figure, the line AC is called the *air-profile* (usually to be considered horizontal and straight), while the line ABC , or profile of the bed and banks, is called the *wetted perimeter*. It is evident that the ratio of the wetted perimeter to the whole perimeter, though never $< \frac{1}{3}$, varies with the form of the transverse section.

In a longitudinal section of the stream, $EFHG$, the angle made by a surface filament EF with the horizontal is called the *slope*, and is measured by the ratio $s = h : l$, where l is the length of a portion of the filament and $h =$ the *fall*, or *vertical* distance between the two ends of that length. The angle between the horizontal and the line HG along the bottom is not necessarily equal to that of the surface, unless the portion of the stream forms a prism; i.e., the slope of the bed does not necessarily $= s =$ that of surface.

EXAMPLES.—The old Croton Aqueduct has a slope of 1.10 ft. per mile; i.e., $s = .000208$. The new aqueduct (for New

York) has a slope $s = .000132$, with a larger transverse section. For large sluggish rivers s is much smaller.

539. Velocity Measurements.— Various instruments and methods may be employed for this object, some of which are the following:

Surface-floats are small balls, or pieces of wood, etc., so colored and weighted as to be readily seen, and still but little affected by the wind. These are allowed to float with the current in different parts of the width of the stream, and the surface velocity c in each experiment computed from $c = l \div t$, where l is the distance described between parallel transverse alignments (or actual ropes where possible), whose distance apart is measured on the bank, and $t =$ the time occupied.

Double-floats. Two balls (or small kegs) of same bulk and condition of surface, one lighter, the other heavier than water, are united by a slender chain, their weights being so adjusted that the light ball, without projecting notably above the surface, buoys the other ball at any assigned depth. Fig. 603.

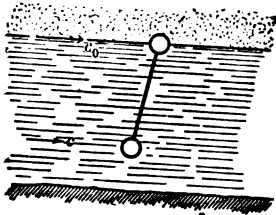

FIG. 603.

It is assumed that the combination moves with a velocity c' , equal to the arithmetic mean of the surface velocity c_s of the stream and that, c_d , of the water filaments at the depth of the lower ball, which latter, c_d , is generally less than c_s . That is, we have

$$c' = \frac{1}{2}(c_s + c_d) \quad \text{and} \quad \therefore c = 2c' - c_s \dots \dots (1)$$

Hence, c_s having been previously obtained, eq. (1) gives the velocity c at any depth of the lower ball, c' being observed.

The *floating staff* is a hollow cylindrical rod, of adjustable length, weighted to float upright with the top just visible. Its observed velocity is assumed to be an average of the velocities of all the filaments lying between the ends of the rod.

Woltmann's Mill; or *Tachometer*; or *Current-meter*, Fig. 604, consists of a small wheel with inclined floats (or of a small

“screw-propeller” wheel *S*) held with its plane \perp to the current, which causes it to revolve at a speed nearly proportional to the velocity, c , of the water passing it. By a screw-gearing *W* on the shaft, connection is made with a counting apparatus to record the number of revolutions. Sometimes a vane *B* is attached, to compel the wheel to face the current. It is either

held at the extremity of a pole or, by being adjustable along a vertical staff fixed in the bed, may be set at any desired depth below the surface. It is usually so designed as to be thrown in and out of gear by a cord and spring, that the time of making the indicated number of revolutions may be exactly noted.

By experiments in currents of known velocities a table or formula can be constructed by which to interpret the indications of any one instrument; i.e., to find the velocity c of the current corresponding to an observed number of revolutions per minute.

A peculiar form of this instrument has been recently invented, called the *Ritchie-Haskell Direction-current Meter*, for which the following is claimed: “This meter registers electrically on dials in boat from which used, the *direction* and *velocity*, simultaneously, of any current. Can be used in river, harbor, or ocean currents.”

Pitot's Tube consists in principle of a vertical tube open above, while its lower end, also open, is bent horizontally upstream; see *A* in figure. After the oscillations have ceased, the water in the tube remains

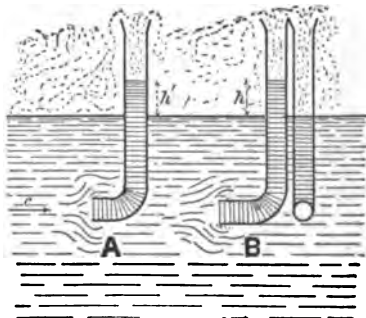

FIG. 605.

the water in the tube remains

stationary with its free surface a height, h' , above that of the stream, on account of the continuous impact of the current against the lower end of the column. By the addition of another vertical tube (see B in figure) with the face of its lower (open) end parallel to the current (so that the water-level in it is the same as that of the current), both tubes being provided with stop-cocks, we may, after closing the stop-cocks, lift the apparatus into a boat and read off the height h' at leisure. We may also cause both columns of water to mount, through flexible tubes, into convenient tubes in the boat by putting the upper ends of both tubes in communication with a receiver of rarefied air, and thus watch the oscillations and obtain a more accurate value of h' . [See Van Nostrand's Mag. for Mar. '78, p. 255.] Theoretically (see § 565), the thickness of the walls of the tube at the lower end being considerable, we have

$$c = \sqrt{gh'} \dots \dots \dots (1)$$

as a relation between c , the velocity of the particles impinging on the lower end, and the static height h' (§ 565). Eq. (1) is verified fairly well by Weisbach's experiments with fine instruments, used with velocities of from 0.32 to 1.24 meters per second. Weisbach found

$$c = \left[3.54 \sqrt{h' \text{ (in meters)}} \right] \text{ met. per sec.,}$$

whereas eq. (1) gives

$$c = \left[3.133 \sqrt{h' \text{ (in meters)}} \right] \text{ met. per sec.}$$

In the instruments used by Weisbach the end of the tube turning up-stream was probably straight; i.e., neither flaring nor conically convergent. A change in this respect alters the relation between c and h' ; see § 565 for Pitot's and Darcy's results.

Pitot's Tube, though simple, is not so accurate as the tachometer.

The *Hydrometric Pendulum*, a rather uncertain instrument, is readily understood from Fig. 606. The side AB , of the quadrant ABC , being held vertical, the plane of the quadrant is made parallel to the current. The angle θ between the cord and the vertical depends on G , the *effective weight* (i.e., actual weight diminished by the buoyant effort) of the ball (heavier than water), and the amount of P , the impulse or horizontal pressure of the current against the latter, since the cord will take the direction of the resultant R , for equilibrium.

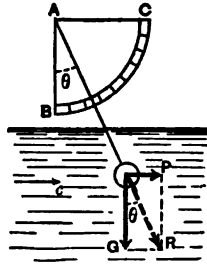

FIG. 606.

Now P (see § 572) for a ball of given size and character of surface varies (nearly) as the square of the velocity; i.e., if P' is the impulse on a given *stationary* ball, when the velocity of the current = c' , then for any other velocity c we have

$$P = \text{impulse} = \frac{P'}{c'^2} c^2. \quad \dots \quad (2)$$

From this and the relation $\tan \theta = \frac{P}{G}$ we derive

$$c = \sqrt{\frac{Gc'^2}{P'}} \cdot \sqrt{\tan \theta}. \quad \dots \quad (3)$$

With a given instrument and a *specified system* of units, the numerical value of the first radical may be determined as a *single quantity*, by experimenting with a known velocity and the value of θ then indicated, and may then, as a constant factor, be employed in (3) for finding the value of c for *any* observed value of θ ; but the *same units* must be used as before.

540. Velocities in Different Parts of a Transverse Section.—

The results of velocity-measurements made by many experimenters do not agree in supporting any very definite relation between the greatest surface velocity (c_{max}) of a transverse

section and the velocities at other points of the section, but establish a few general propositions :

1st. In any vertical line the velocity is a maximum quite near the surface, and diminishes from that point both toward the bottom and toward the surface.

2d. In any transverse horizontal line the velocity is a maximum near the middle of the stream, diminishing toward the banks.

3d. The *mean velocity* = v , of the whole transverse section, i.e., the velocity which must be multiplied by the area, F , of the section, to obtain the volume delivered per unit of time,

$$Q = Fv, \dots \dots \dots (1)$$

is about 83 per cent of the maximum surface velocity (c_0 , max.) observed when the air is still ; i.e.,

$$v = 0.83 \times (c_0 \text{ max.}) \dots \dots \dots (2)$$

Of eight experimenters cited by Prof. Bowser, only one gives a value (= 0.62) differing more than .05 from .83, while others obtained the values .82, .78, .82, .80, .82, .83.

In the survey of the Mississippi River by Humphreys and Abbot, 1861, it was found that the law of variation of the velocity in any given vertical line could be fairly well represented by the ordinates of a parabola (Fig. 607) with its axis



FIG. 607.

horizontal and its vertex at a distance d_1 below the surface according to the following relation, f'' being a number dependent on the force of the wind (from 0 for no wind to 10 for a hurricane) :

$$d_1 = [0.317 \pm 0.06 f''] d ; \dots (3)$$

where d is the total depth, and the double sign is to be taken + for an up-stream, - for a down-stream, wind. The following relations were also based on the results of the survey :

$$\text{(putting, for brevity, } B = 1.69 \div \sqrt{d + 1.5}) \dots (4)$$

$$c = c_a - \sqrt{Bv} \left(\frac{z - d_1}{d} \right)^2, \dots \dots \dots (5)$$

$$c_m = \frac{2}{3}c_a + \frac{1}{3}c_d + \frac{d_1}{d} \left(\frac{1}{3}c_s - \frac{1}{3}c_a \right), \dots \dots \dots (6)$$

and

$$c_{1d} = c_m + \frac{1}{1.49} \sqrt{Bv}. \dots \dots \dots (7)$$

(These equations are not of homogeneous form, but call for the foot and second as units.)

In (4), (5), and (6),

- c = velocity at any depth z below the surface ;
- c_m = mean velocity in the vertical curve ;
- c_{d_1} = max. " " " "
- $c_{\frac{1}{2}d_1}$ = " at mid-depth ;
- c_d = velocity at bottom ;
- v = mean velocity of the whole transverse section.

It was also found that the parameter of the parabola varied inversely as the square root of the mean velocity c_m of curve.

In general the bottom velocity (c_d) is somewhat more than $\frac{1}{2}$ the maximum velocity (c_{d_1}) in the same vertical. In the Mississippi the velocity at mid-depth in any vertical was found to be very nearly .96 of the surface velocity in the same vertical; this fact is important, as it simplifies the approximate gauging of a stream.

541. Gauging a Stream or River.—Where the relation (eq. (2), § 540) $v = .83 (c_{max})$ is not considered accurate enough for substitution in $Q = Fv$ to obtain the volume of discharge (or delivery) Q of a stream per time-unit, the transverse section may be divided into a number of subdivisions as in Fig. 608, of widths a_1, a_2 , etc., and mean depths d_1, d_2 , etc., and the respective mean velocities, c_1, c_2 , etc., computed from measurements with current-meters; whence we may write

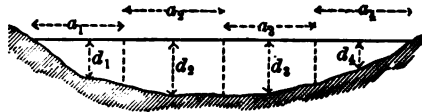

FIG. 608.

$$Q = a_1 d_1 c_1 + a_2 d_2 c_2 + a_3 d_3 c_3 + \text{etc.} \dots \dots (7)$$

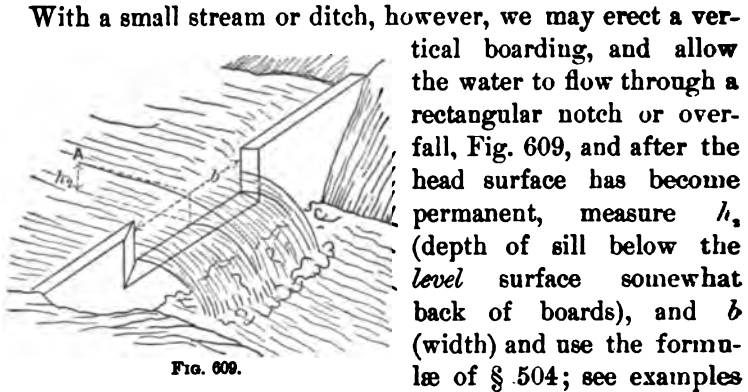

FIG. 609.

in that article.

542. Uniform Motion in an Open Channel.—We shall now consider a straight stream of indefinite length in which *the flow is steady*, i.e., a *state of permanency exists*, as distinguished from a freshet or a wave. That is, the flow is steady when the water assumes fixed values of mean velocity v , and sectional area F , on passing a given point of the bed or bank; and the

$$\text{Eq. of continuity} \dots Q = Fv = F_1v_1 = F_2v_2 = \text{constant} \dots (1)$$

holds good whether those sections are equal or not.

By *uniform motion* is meant that (the section of the bed and banks being of constant size and shape) the slope of the bed, the quantity of water (volume = Q) flowing per time-unit, and the extent of the wetted perimeter, are so adjusted to each other that the mean velocity of flow is the same in all transverse sections, and consequently the area and shape of the transverse section is the same at all points; and *the slope of the surface = that of the bed*. We may therefore consider, for simplicity, that we have to deal with a prism of water of indefinite length sliding down an inclined rough bed of constant slope and moving with *uniform* velocity (viz., the mean velocity v common to all the sections); that is, there is *no acceleration*. Let Fig. 610 show, free, a portion of this prism, of length = l , and having its bases γ to the bed and surface.

The hydrostatic pressures at the two ends balance each other from the identity of conditions. The only other forces having

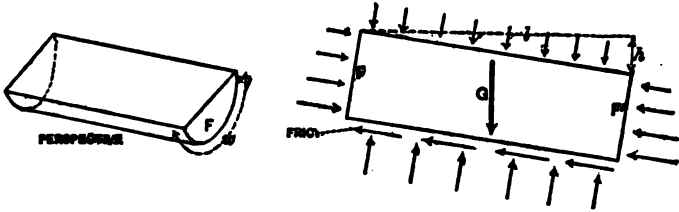

FIG. 610.

components parallel to the bed and surface are the *weight* $G = Fly$ of the prism (where γ = heaviness of water) making an angle = s (= slope) with a normal to the surface, and the *friction* between the water and the bed which is parallel to the surface. The amount of this friction for the prism in question may be expressed as in § 510, viz.:

$$P = \text{fric.} = fS\gamma \frac{v^2}{2g} = f\omega l\gamma \frac{v^2}{2g}, \dots (2)$$

in which $S = \omega l$ = rubbing surface (area) = wetted perimeter, ω , \times length (see § 538), and f an abstract number. Since the mass of water in Fig. 610 is supposed to be in relative equilibrium, we may apply to it the laws of motion of a rigid body, and since the motion is a *uniform translation* (§ 109) the components, parallel to the surface, of all the forces must balance.

$$\therefore G \sin s \text{ must} = P = \text{fric.}; \therefore Fly \frac{h}{l} = f\omega l\gamma \frac{v^2}{2g};$$

whence

$$h = f \frac{\omega l}{F} \cdot \frac{v^2}{2g}, \dots (3')$$

or

$$h = f \frac{l}{R} \cdot \frac{v^2}{2g}, \dots (3)$$

in which $F \div \omega$ is called R , the *hydraulic mean depth*, or *hydraulic radius*. (3) is sometimes expressed by saying that

the whole fall, or head, h , is (in uniform motion) absorbed in friction-head. Also, since the slope $s = h \div l$, we have

$$v = \sqrt{\frac{2g}{f}} \sqrt{Rs}; \text{ or, } v = A \sqrt{Rs}, \dots (4)$$

which is of the same form as Chézy's formula in § 519 for a very long straight pipe (the slope s of the actual surface in this case corresponding to the slope along piezometer-summits in that of a closed pipe). In (4) the coefficient $A = \sqrt{2g \div f}$ is not, like f , an abstract number, but its numerical value depends on the system of units employed.

542a. Experiments on the Flow of Water in Open Channels.—Those of Darcy and Bazin, begun in 1855 and published in 1865 (“Recherches Hydrauliques”), were very carefully conducted with open conduits of a variety of shapes, sizes, slopes, and character of surface. In most of these a uniform flow was secured before the taking of measurements. The velocities ranged between from about 0.5 to 8 or 10 ft. per second, the hydraulic radii from 0.03 to 3.0 ft., with deliveries as high as 182 cub. ft. per second. For example, the following results were obtained in the canals of Marseilles and Craponne, the quantity A being for the foot and second. The sections were nearly all rectangular. See eq. (4) above.

No.	Q . (cub. ft. per sec.)	R . (ft.)	s . abs. numb.	v . (ft. per sec.)	A . (foot and sec.)	Character of the masonry surface.
1	182.78	1.504	.0087	10.26	137.1	Very smooth.
2	143.74	1.774	.00084	5.55	125.	Quite “
3	43.93	.708	.029	11.23	78.4	“
4	43.93	.615	.060	13.93	73.5	Hammered stone.
5	43.93	.881	.0121	7.58	73.5	Rather rough.
6	43.93	.835	.014	8.36	77.3	
7	167.68	2.871	.00043	2.54	72.2	Mud and vegetation.

[In Experiment No. 7 the flow had not fully reached a state of permanency.]

Fteley and Stearns's experiments on the Sudbury conduit at Boston, Mass. (*Trans. A. S. C. E.*, '83), from 1878 to 1880, are also valuable. This open channel was of brick masonry with

good mortar joints, and about 9 ft. wide; the depths of water ranging from 1.5 to 4.5 ft. With plaster of pure cement on the bed in one of the experiments the high value of $A = 153.6$ was reached (foot and second), with $v = 2.805$ ft. per second, $R = 2.111$ ft., $s = .0001580$, and $Q = 87.17$ cu. ft. per second.

Captain Cunningham, in his experiments on the Ganges Canal at Roorkee, India, in 1881, found A to range from 48 to 130 (foot and second).

Humphreys and Abbot's experiments on the Mississippi River and branches (see § 540), with values of $R =$ from 2 or 3 ft. to 72 ft., furnish values of $A =$ from 53 to 167 (foot and second).

542b. Kutter's Formula.—The experiments upon which Weisbach based his deductions for f , the coefficient of fluid friction, were scanty and on too small a scale to warrant general conclusions. That author considered that f depended only on the velocity, disregarding altogether the degree of roughness of the bed, and gave a table of values in accordance with that view, these values ranging from .0075 for 15 ft. per sec. to .0109 for 0.4 ft. per sec.; but in 1869 Messrs. Kutter and Ganguillet, having a much wider range of experimental data at command, including those of Darcy and Bazin, and those obtained on the Mississippi River, evolved a formula, known as *Kutter's Formula*, for the uniform motion of water in open channels, which is claimed to harmonize in a fairly satisfactory manner the chief results of the best experiments in that direction. They make the coefficient A in eq. (4) (or rather the factor $\frac{1}{\sqrt{f}}$ contained in A) a function of R , s , and also n an abstract number, or *coefficient of roughness*, depending on the nature of the surface of the bed and banks; viz.,

$$v \text{ in } \left. \begin{array}{l} \text{ft.} \\ \text{per} \\ \text{sec.} \end{array} \right\} = \left[\frac{41.6 + \frac{1.811}{n} + \frac{.00281}{s}}{1 + \left(41.6 + \frac{.00281}{s} \right) \frac{1}{\sqrt{R(\text{in feet})}}} \right] \sqrt{R(\text{in ft.}) \times s} \dots (5)$$

which is *Kutter's Formula*.

That is, comparing (5) with (4), we have f a function of n , R , and s , as follows:

$$f = \left[\frac{1 + \left[41.6 + \frac{.00281}{s} \right] \frac{n}{\sqrt{R \text{ in ft.}}}}{5.184 + \frac{.2256}{n} + \frac{.00035}{s}} \right]^2 \dots (6)$$

From (6) it appears that f decreases with an increasing R , as has been also noted in the case of closed pipes (§ 517); that it increases with increasing roughness of surface; and that it is somewhat dependent on the slope. The makers of the formula give the following values for n .

Values of n . $n =$

- .009 for well-planed timber bed;
- .010 for plaster in pure cement;
- .011 for plaster in cement with $\frac{1}{2}$ sand;
- .012 for unplaned timber;
- .013 for ashlar and brickwork; *
- .015 for canvas lining on frames;
- .017 for rubble;
- .020 for canals in very firm gravel;
- .025 for rivers and canals in perfect order and regimen, and perfectly free from stones and weeds;
- .030 for rivers and canals in moderately good order and regimen, having stones and weeds occasionally;
- .035 for rivers and canals in bad order and regimen, overgrown with vegetation and strewn with stones or detritus of any sort.

Kutter's Formula is claimed to apply to all kinds and sizes of watercourses, from large rivers to sewers and ditches; for *uniform motion*. If \sqrt{R} is the unknown quantity, Kutter's Formula leads to a quadratic equation; if s the slope, to a cubic. Hence, to save computation, tables have been prepared, some of which will be found in vol. 28 of Van Nostrand's Magazine

* For ordinary brick sewers Mr. R. F. Hartford claims that $n = .014$ gives good results. See Jour. Eng. Societies for '84-'85, p. 220.

(pp. 135 and 393) (sewers), and in Jackson's works on Hydraulics (rivers).

The following table will give the student an idea of the variation of the coefficient $A = \sqrt{\frac{2g}{f}}$, of eq. (4), or large

bracket of eq. (5), with different hydraulic radii, slopes, and values of n , according to Kutter's Formula; from $R = \frac{1}{2}$ ft., for a small ditch or sluice-way (or a wide and shallow stream), to $R = 15$ ft., for a river or canal of considerable size. Under each value of R are given two values of A ; one for a slope of $s' = .001$, and the other for $s'' = .00005$. All these values of A imply the use of the foot and second.

These values of A have been scaled by the writer from a diagram given in Jackson's translation of Kutter's "*Hydraulic Tables*," and are therefore only approximate. The corresponding values of f , the coefficient of fluid friction, can be

computed from $f = \frac{2g}{A^2}$.

n	R = 1/2 ft.		R = 1 ft.		R = 3 ft.		R = 6 ft.		R = 15 ft.	
	for s'	for s''	for s'	for s''	for s'	for s''	for s'	for s''	for s'	for s''
0.010	138	114	149	137	174	174	187	196	199	222
0.015	83	68	96	87	118	118	128	137	138	158
0.020	58	49	70	68	87	87	98	106	110	126
0.025	45	38	54	48	70	70	80	85	90	106
0.030	36	31	43	40	58	58	66	72	77	90
0.035	28	25	33	34	50	50	58	64	68	81

The formula used in designing the New Aqueduct for New York City, in 1885, by Mr. Fteley, consulting engineer, was [see (4)]

$$v(\text{ft. per sec.}) = 142 \sqrt{R(\text{in ft.}) \times s}, \dots (7)$$

whereas Kutter's Formula gives for the same case (a circular* section of 14 ft. diameter, and slope of 0.7 ft. to the mile), with $n = 0.013$,

$$v(\text{ft. per sec.}) = 140.7 \sqrt{R(\text{in ft.}) \times s} \dots (8)$$

* The aqueduct has this circular form for a small portion, only, of its length; a "horseshoe" section of very nearly the same flowing capacity being given to the greater portion of the remainder.

To quote from a letter of Mr. I. A. Shaler of the Aqueduct Corps of Engineers, "Mr. Fteley states that the cleanliness of the conduit (Sudbury) had much to do in affecting the flow. He found the flow to be increased by 7 or 8 per cent in a portion which had been washed with a thin wash of Portland cement."

EXAMPLE 1.—A canal 1000 ft. long of the trapezoidal section in Fig. 611 is required to deliver 300 cubic ft. of water

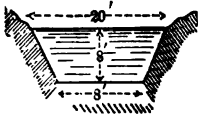

FIG. 611.

per second with the water 8 ft. deep at all sections (i.e., with uniform motion), the slope of the bank being such that for a depth of 8 ft. the width of the water surface (or length of air-profile) will be 20 ft.; and the coefficient for roughness being $n = .020$. What is the necessary slope to be given to the bed (slope of bed = that of surface, here) (ft., lb., sec.)?

The mean velocity

$$v = Q \div F = 300 \div \frac{1}{2}(20 + 8)8 = 2.67 \text{ ft. per sec.}$$

[So that the surface velocity of mid-channel in any section would probably be $(c_{\text{max}}) = v \div 0.83 = 3.21$ ft. per sec. (eq. (2), § 540).]

The wetted perimeter

$$w = 8 + 2\sqrt{8^2 + 6^2} = 28 \text{ ft.,}$$

and therefore the mean hydraulic depth

$$= R = F \div w = 112 \div 28 = 4 \text{ ft.}$$

To obtain a first approximation for the slope, we may use the value $f = .00795$ given by Weisbach for a velocity of 2.67 ft. per sec., and obtain, from (3),

$$h = \frac{.00795 \times 1000 \times 28(2.67)^2}{112 \times 2 \times 32.2} = 0.221 \text{ ft.};$$

i.e., $s = h \div l = .000221$.

With this value for the slope and $R = 4$ ft. (see above), we then have, from eq. (6) (putting $n = .020$),

$$f = \left[\frac{1 + \left(41.6 + \frac{.00281}{.000221} \right) \frac{.020}{\sqrt{4} \text{ ft.}}}{5.184 + \frac{.2256}{.020} + \frac{.00035}{.000221}} \right]^2 = .0071,$$

with which value of f we now obtain

$$h = 0.200 \text{ feet; i.e., slope} = s = .00020.$$

EXAMPLE 2.—If the bed of a creek falls 20 inches every 1500 ft. of length, what volume of water must be flowing to maintain a uniform mean depth of $4\frac{1}{2}$ ft., the corresponding surface-width being 40 ft., and wetted perimeter 46 ft.? The bed is “in moderately good order and regimen;” use Kutter’s Formula, putting $n = 0.030$ (ft. and sec.).

First we have

$$\sqrt{Rs} = \sqrt{(40 \times 4\frac{1}{2}) \div (46 \times \frac{1500}{12})} = .066,$$

while $\sqrt{R} \text{ (ft.)} = 1.98$, and the slope $= s = \frac{20}{12} \div 1500 = .00111$; hence

$$v = \frac{\left[41.6 + \frac{1.811}{.030} + \frac{.00281}{.00111} \right] \times 0.066}{1 + \left[41.6 + \frac{.00281}{.00111} \right] \frac{0.030}{1.98}} = \frac{104.43 \times .066}{1.6685},$$

or

$$v = 4.13 \text{ ft. per sec.}$$

Hence, also,

$$Q = Fv = 40 \times 4\frac{1}{2} \times 4.13 = 743.4 \text{ cub. ft. per sec.}$$

[N.B. Weisbach works this same example by eq. (3) with a value of f taken from his own table, his result being $v = 6.1$

ft. per sec., which would probably be attained in practice only by making the bed and banks smoother than as given.]

EXAMPLE 3.—The desired transverse water-section of a canal is given in Fig. 612. The slope is to be 3 ft. in 1600; i.e., $s = 3 \div 1600$; or, for $l = 1600$ ft., $h = 3$ ft. What must be the velocity (mean) of each section, for a *uniform motion*; the corresponding volume delivered per sec., $Q = Fv$, = ?; assuming that the character of the surface warrants the value $n = .030$?

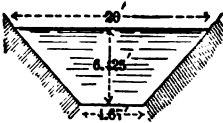

FIG. 612.

Knowing the slope $s = 3 \div 1600$; and the hydraulic radius $R = F \div w = 79.28$ sq. ft. \div 24.67 ft., = 3.215 feet; with $n = .030$ we substitute directly in eq. (5), obtaining $v = 4.67$ ft. per sec.; whence $Q = Fv = 370$ cub. ft. per sec.

543. Hydraulic Mean Depth for a Minimum Frictional Resistance.—We note, from eq. (3), § 542, that if an open channel of given length l and sectional area F is to deliver a given volume, Q , per time-unit with uniform motion, so that the common mean velocity v of all sections ($= Q \div F$) is also a given quantity, the necessary fall = h , or slope $s = h \div l$, is seen to be inversely proportional to R , the hydraulic mean depth of the section, $= (F \div w)$, = sectional area \div wetted perimeter.

For h to be as small as possible, we may design the form of transverse section, so as to make R as large as possible; i.e., to make the wetted perimeter a minimum for a given F ; for in this way a minimum of frictional contact, or area of rubbing surface, is obtained for a prism of water of given sectional area F and given length l .

In a closed pipe running full the wetted perimeter is the whole perimeter; and if the given sectional area is shaped in the form of a *circle*, the wetted perimeter, $= w$, is a minimum (and R a maximum). If the full pipe must have a polygonal shape of n sides, then the *regular* polygon of n sides will provide a minimum w .

Whence it follows that if the pipe or channel is running

half full, and thus becomes an *open channel*, the semicircle, of all curvilinear water profiles, gives a minimum w . Also, of all trapezoidal profiles with banks at 60° with the horizontal the half of a regular hexagon gives a minimum w . Among all rectangular sections the half square gives a minimum w ;

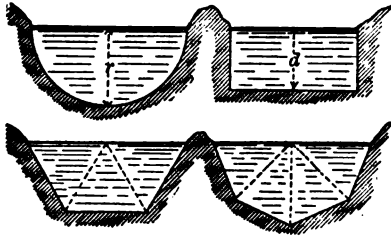

FIG. 613.

and of all half octagons the half of a regular octagon gives a minimum w (and max. R) for a given F . See Fig. 613 for all these.

The egg-shaped outline, Fig. 614, small end down, is frequently given to sewers in which it is important that the different velocities of the water at different stages (depths) of flow (depending on the volume of liquid passing per unit-time) should not vary widely from each other. The lower portion ABC , providing for the lowest stage of flow AB , is nearly semicircular, and thus induces a velocity of flow (the slope being constant at all stages) which does not differ extremely from that occurring when the water flows at its highest stage DE , although this latter velocity is the greater; the reason being that ABC from its advantageous form has a hydraulic radius, R , larger in proportion to its sectional area, F , than DCE .

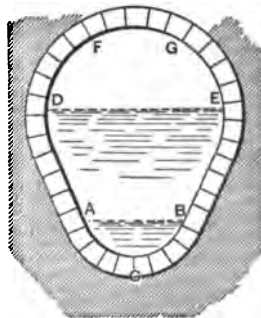

FIG. 614.

That is, $F \div w$ for ABC is more nearly equal to $F \div w$ for DEC than if DEC were a semicircle, and the velocity at the lowest stage may still be sufficiently great to prevent the deposit of sediment. See § 575.

544. Trapezoid of Fixed Side-slope.—For large artificial water-courses and canals the trapezoid, or three-sided water-profile (symmetrical), is customary, and the inclination of the bank,

or angle θ with the horizontal, Fig. 615, is often determined

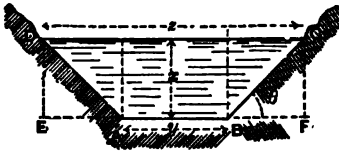

FIG. 615.

by the nature of the material composing it, to guard against washouts, caving in, etc. We are therefore concerned with the following problem: *Given the area, F , of the transverse section,*

and the angle θ , required the value of the depth x (or of upper width z , or of lower width y , both of which are functions of x) to make the hydraulic mean depth, $R = F \div w$, a maximum, or $w \div F$ a minimum. F is constant.

From the figure we have

$$w = \overline{AB} + 2\overline{BC} = y + 2x \operatorname{cosec} \theta, \dots (1)$$

and

$$F = yx + x^2 \cot \theta;$$

whence

$$y = \frac{1}{x} \cdot (F - x^2 \cot \theta), \dots (2)$$

substituting which in (1) and dividing by F , noting that $2 \operatorname{cosec} \theta - \cot \theta = \frac{2 - \cos \theta}{\sin \theta}$, we have

$$\frac{w}{F} = \frac{1}{R} = \frac{1}{x} + \frac{2 - \cos \theta}{F \sin \theta} \cdot x \dots (3)$$

For a minimum w we put

$$\frac{d\left(\frac{w}{F}\right)}{dx} = 0; \text{ i.e., } -\frac{1}{x^2} + \frac{2 - \cos \theta}{F \sin \theta} = 0;$$

$$\therefore x (\text{for max. or min. } w) = \pm \sqrt{\frac{F \sin \theta}{2 - \cos \theta}}$$

The + sign makes the second derivative positive, and hence for a min. w or max. R we have

$$x (\text{call it } x') = x' = \frac{\sqrt{F \sin \theta}}{\sqrt{2 - \cos \theta}}, \dots (4)$$

while the corresponding values for the other dimensions are

$$y' = \frac{F}{x'} - x' \cot. \theta \dots \dots \dots (5)$$

and

$$z' = y' + 2x' \cot. \theta = \frac{F}{x'} + x' \cot. \theta \dots \dots (6)$$

For the corresponding hydraulic mean depth R' [see (2)], i.e., the max. R , we have

$$\frac{1}{R'} = \frac{1}{x'} + \frac{2 - \cos \theta}{F \sin \theta} x' = \frac{2}{x'}; \dots \dots (7)$$

$$\therefore R' = \frac{1}{2} x' = \frac{1}{2} \sqrt{\frac{F \sin \theta}{2 - \cos \theta}} \dots \dots (8)$$

Equations (4), (5), . . . (8) hold good, then, for the trapezoidal section of least frictional resistance for a given angle θ .

PROBLEM.—Required the dimensions of the trapezoidal section of minimum frictional resistance for $\theta = 45^\circ$, which with $h = 6$ inches fall in every 1200 feet ($= l$) is required to deliver $Q = 360$ cub. ft. of water per minute with *uniform motion*.

Here we have given, with uniform motion, h , l , and Q , with the requirement that the section shall be trapezoidal, with $\theta = 45^\circ$, and of minimum frictional resistance. The following equations are available:

$$\text{Eq. of continuity } \dots Q = Fv, \dots \dots (1')$$

$$\left. \begin{array}{l} \text{Eq. (8) preceding, for con-} \\ \text{dition of least resistance} \end{array} \right\} R' = \frac{1}{2} \sqrt{\frac{\sin \theta}{2 - \cos \theta}} \sqrt{F} \dots (2')$$

$$\left. \begin{array}{l} \text{From eq. } \\ \text{(3), § 542, } \end{array} \right\} \text{for uniform motion, } h = f \frac{l}{R} \cdot \frac{v^3}{2g} \dots \dots (3')$$

There are three unknown quantities, v , F , and R' . Solve

(1') for v ; solve (2') for R' ; substitute their values in (3'); whence

$$\frac{h \sqrt{\sin \theta}}{\sqrt{2 - \cos \theta}} = \frac{f}{2g} \cdot \frac{2l}{\sqrt{F'}} \cdot \frac{Q'}{F'^2}; \therefore F = \left[\frac{2f l \sqrt{2 - \cos \theta} Q'}{2gh \sqrt{\sin \theta}} \right]^2. \quad (4')$$

Since f cannot be exactly computed in advance, for want of knowing the value of R , we calculate it approximately [eq. (6), § 542b] for an assumed value of R , insert it in the above equation (4'), and thus find an approximate value of F ; and then, from (8), a corresponding value of R , from which a new value of f can be computed. Thus after one or two trials a satisfactory adjustment of dimensions can be secured.

545. Variable Motion.—If a steady flow of water of a delivery $Q, = Fv, = \text{constant}$, takes place in a straight open channel the slope of whose bed has not the proper value to maintain a “*uniform motion*,” then “*variable motion*” ensues (the flow is still steady, however); i.e., although the mean velocity in any one transverse section remains fixed (with lapse of time), this velocity has different values for different sections; but as the eq. of continuity,

$$Q = Fv = F_1v_1 = F_2v_2, \text{ etc.},$$

still holds (since the flow is steady), the different sections

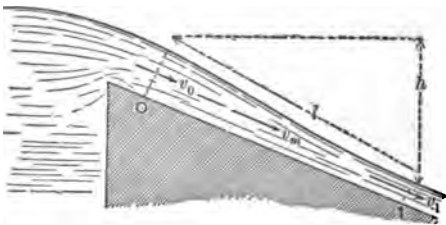

FIG. 616.

have different areas. If, Fig. 616, a stream of water flows down an inclined trough without friction, the relation between the velocities v_0 and v_1 at any two sections 0 and 1 will be

the same as for a material point sliding down a guide without friction (see § 79, latter part), viz.:

$$\frac{v_1^2}{2g} = \frac{v_0^2}{2g} + h, \dots \dots \dots (1)$$

an equation of heads (really a case of Bernoulli's Theorem, § 492). But, considering friction on the bed, we must subtract the *mean friction-head* $f \frac{l}{R} \cdot \frac{v_m^2}{2g}$ [see eqs. (3) and (3'), § 542] lost between 0 and 1; this friction-head may also be written thus: $f \frac{l w_m v_m^2}{F_m 2g}$; and therefore eq. (1) becomes

$$\frac{v_1^2}{2g} = \frac{v_0^2}{2g} + h - \frac{f w_m}{F_m} l \cdot \frac{v_m^2}{2g}, \dots \dots (2)$$

which is the formula for *variable motion*; and in it l is the length of the section considered, which should be taken short enough to consider the surface straight between the end-sections, and the latter should differ but slightly in area. The subscript m may be taken as referring to the section midway between the ends, so that $v_m^2 = \frac{1}{2}(v_0^2 + v_1^2)$. The wetted perimeter $w_m = \frac{1}{2}(w_0 + w_1)$, and $F_m = \frac{1}{2}(F_0 + F_1)$. Hence eq. (2) becomes

$$h = \frac{v_1^2}{2g} - \frac{v_0^2}{2g} + \frac{\frac{1}{2} f (w_0 + w_1) l}{F_0 + F_1} \cdot \frac{v_0^2 + v_1^2}{2g}; \dots (3)$$

and again, by putting $v_0 = Q \div F_0$, $v_1 = Q \div F_1$, we may write

$$h = \left[\frac{1}{F_1^2} - \frac{1}{F_0^2} + \frac{1}{2} \cdot \frac{f l (w_0 + w_1)}{F_0 + F_1} \left(\frac{1}{F_0^2} + \frac{1}{F_1^2} \right) \right] \frac{Q^2}{2g}; \dots (4)$$

whence

$$Q = \frac{\sqrt{2gh}}{\sqrt{\frac{1}{F_1^2} - \frac{1}{F_0^2} + \frac{1}{2} \cdot \frac{f l (w_0 + w_1)}{F_0 + F_1} \cdot \left[\frac{1}{F_0^2} + \frac{1}{F_1^2} \right]}} \dots (5)$$

From eq. (4), having given the desired shapes, areas, etc., of the end-sections and the volume of water, Q , to be carried per unit of time, we may compute the necessary fall, h , of the surface, in length = l ; while from eq. (5), having observed in an actual water-course the values of the sectional areas F_0 and F_1 , the wetted perimeters w_0 and w_1 , the length, = l , of the por

tion considered, we may calculate Q and thus gauge the stream approximately, without making any velocity measurements.

As to the value of f , we compute it from eq. (6), § 542b, using for R a mean between the values of the hydraulic radii of the end-sections.

546. Bends in an Open Channel.—According to Humphreys and Abbot's researches on the Mississippi River the loss of head due to a bend may be put

$$h_r = \frac{v^2}{536} \frac{6\delta}{\pi}, \dots \dots \dots (1)$$

in which v must be in *ft. per sec.*, and δ , the angle ABC , Fig. 617, must be in π -measure, i.e. in radians. The section F must be greater than 100 sq. ft., and the slope s less than .0008. v is the mean velocity of the water. Hence if a bend occurred in a portion of a stream of length l , eq. (3) of § 542 becomes

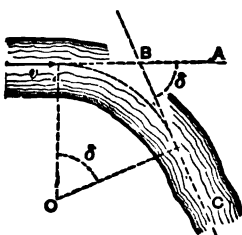

FIG. 617.

$$h = \frac{fl}{R} \frac{v^2}{2g} + \frac{6}{536} \frac{v^2 \delta}{\pi} \dots \text{[ft. and sec.],} \dots (2)$$

while eq. (2) of § 545 for variable motion would then become

$$\frac{v_1^2}{2g} = \frac{v_0^2}{2g} + h - \frac{f w_m l}{F_m} \frac{v_m^2}{2g} - \frac{6}{536} \frac{v^2 \delta}{\pi} \dots \text{(ft. and sec.)} \dots (3)$$

(v and δ as above.) (For "radian" see p. 544.)

547. Equations for Variable Motion, introducing the Depths.—Fig. 618. The slope of the bed being $\sin \alpha$ (or simply α , π meas.), while that of the surface is different, viz.,

$$\sin \beta = s = h \div l,$$

we may write

$$h = d_0 + l \sin \alpha - d_1,$$

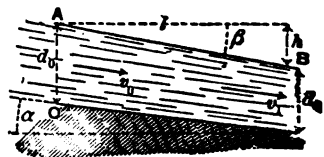

FIG. 618.

in which d_0 and d_1 are the depths at the end-sections of the portion considered (steady flow with variable motion). With these substitutions in eq. (4), § 545, we have, solving for l ,

$$l = \frac{d_0 - d_1 - \left(\frac{1}{F_1^2} - \frac{1}{F_0^2}\right) \frac{Q^2}{2g}}{\frac{fw_m}{F_0 + F_1} \left(\frac{1}{F_0^2} + \frac{1}{F_1^2}\right) \frac{Q^2}{2g} - \sin \alpha} \dots (1)$$

From which, knowing the slope of the bed and the shape and size of the end-sections, also the discharge Q , we may compute the length or distance, l , between two sections whose depths differ by an assigned amount ($d_0 - d_1$). But we cannot compute the change of depth for an assigned length l from (6). However, if the *width* b of the stream is *constant*, and the same at all depths; i.e., if all sections are rectangles having a common width; eq. (6) may be much simplified by introducing some approximations, as follows: We may put

$$\begin{aligned} \left(\frac{1}{F_1^2} - \frac{1}{F_0^2}\right) \frac{Q^2}{2g} &= \frac{F_0^2 - F_1^2}{F_1^2 F_0^2} \cdot \frac{Q^2}{2g} = \frac{(F_0 - F_1)(F_0 + F_1)}{F_1^2} \cdot \frac{v_0^2}{2g} \\ &= \frac{(d_0 - d_1)(d_0 + d_1)}{d_1^2} \cdot \frac{v_0^2}{2g}, \text{ which approx. } = \frac{2(d_0 - d_1)}{d_0} \cdot \frac{v_0^2}{2g} \end{aligned}$$

and, similarly,

$$\begin{aligned} \frac{w_m}{F_0 + F_1} \left(\frac{1}{F_0^2} + \frac{1}{F_1^2}\right) \frac{Q^2}{2g} &= \frac{w_m (F_0^2 + F_1^2)}{(F_0 + F_1) F_1^2} \cdot \frac{v_0^2}{2g} \\ \text{which approx. } &= \frac{w_m}{d_0 b} \frac{v_0^2}{2g} \end{aligned}$$

Hence by substitution in eq. (6) we have

$$l = \frac{(d_0 - d_1) \left[1 - \frac{2}{d_0} \cdot \frac{v_0^2}{2g}\right]}{\frac{fw_m v_0^2}{d_0 b 2g} - \sin \alpha} \dots (7)$$

547a. Backwater.—Let us suppose that a steady flow has been proceeding with uniform motion (i.e., the surface parallel

to the bed) in an open channel of indefinite extent, and that a vertical wall is now set up across the stream. The water rises and flows over the edge of the wall, or weir, and after a time a steady flow is again established. The depth, y , of the water close to the weir on the up-stream side is greater than d_0 , the original depth. We now have "variable motion" above the weir, and at any distance x up-stream from the weir the new depth y is greater than d_0 . This increase of depth is called backwater, and, though decreasing up-stream, may be perceptible several miles above the weir. Let s be the slope of the original uniform motion (and also of present bed), and v the velocity of the original uniform motion, and let $k = \frac{v^2}{2g}$.

Then, if the section of the stream is a shallow rectangle of constant width, we have the following relation (Rankine):

$$x = \frac{1}{s} \left[y_0 - y + (d_0 - 2k)(\phi - \phi_0) \right], \dots (1)$$

where ϕ is a function of $\frac{y}{d_0}$, as per following table:

For $\frac{y}{d_0} = 1.0$	1.10	1.20	1.30	1.40	1.50	1.60	1.70
$\phi = \infty$.680	.480	.376	.304	.255	.218	.189
For $\frac{y}{d_0} = 1.80$	1.90	2.00	2.20	2.40	2.60	2.80	3.0
$\phi = .166$.147	.132	.107	.089	.076	.065	.056

ϕ_0 is found from $\frac{y_0}{d_0}$, precisely as ϕ from $\frac{y}{d_0}$, by use of the table.

With this table and eq. (1), therefore, we can find x , the distance ("amplitude of backwater") from the weir of the point where any assigned depth y (or "height of backwater," $y - d_0$) will be found.

For example, Prof. Bowser cites the case from D'Aubuisson's Hydraulics of the river Weser in Germany, where the erection of a weir increased the depth at the weir from 2.5 ft. to 10 ft., the flow having been originally "uniform" for 10 miles. Three miles above the dam the *increase* ($y - d_0$) of depth was 1.25 ft., and even at four miles it was 0.75 ft.

CHAPTER VIII.

DYNAMICS OF GASEOUS FLUIDS.

548. Steady Flow of a Gas.—[N.B. The student should now review § 492 up to eq. (5).] The differential equation from which Bernoulli's Theorem was derived for any liquid, *without friction*, was [eq. (5), § 492]

$$\frac{1}{g} v dv + dz + \frac{1}{\gamma} dp = 0, \dots \dots (A)$$

and is equally applicable to the steady flow of a gaseous fluid, but with this difference in subsequent work, that the heaviness, γ (§ 7), of the gas passing different sections of the pipe or stream-line is, or may be, different (though always the same at a given point or section, since the flow is steady). For the present we neglect friction and consider the flow from a large receiver, where the great body of the gas is practically at rest, through an orifice in a thin plate, or a short nozzle with a rounded entrance.

In the steady flow of a gas, since γ is different at different points, the *equation of continuity* takes the form

$$\text{Flow of weight per time-unit} = F_1 v_1 \gamma_1 = F_2 v_2 \gamma_2 = \text{etc.}; \dots (a)$$

i.e., the *weight* of gas passing any section, of area F , per unit of time, is the same as for any other section, or $Fv\gamma = \text{constant}$, γ being the heaviness at the section, and v the velocity.

549. Flow through an Orifice—Remarks.—In Fig. 619 we have a large rigid receiver containing gas at some tension, p_n , higher than that, p_m , of the (still) outside air (or gas), and at some absolute temperature T_n , and of some heaviness γ_n ; that is, in a *state n*. The small orifice of area F being opened, the gas begins to escape, and if the receiver is very large, or if the supply is continually kept up (by a blowing-engine, e.g.), after

a very short time the flow becomes steady. Let nm represent any stream-line (§ 495) of the flow. According to the ideal subdivision of this stream-line into laminæ of equal mass or weight (not equal volume, necessarily) in establishing eq. (A) for any one lamina, each lamina in the lapse of time dt moves into the position just vacated by the lamina next in front, and *assumes precisely the same velocity, pressure, and volume (and there-*

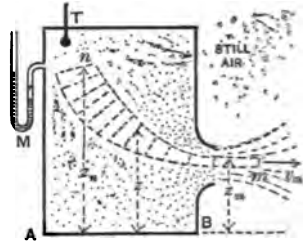

FIG. 619.

fore heaviness) as that front one had at the beginning of the dt. In its progress toward the orifice it expands in volume, its tension diminishes, while its velocity, insensible at n , is gradually accelerated on account of the pressure from behind always being greater than that in front, until at m , in the "throat" of the jet, the velocity has become v_m , the pressure (i.e., tension) has fallen to a value p_m , and the heaviness has changed to γ_m . The temperature T_m (absolute) is less than T_n , since the expansion has been rapid, *and does not depend on the temperature of the outside air or gas into which efflux takes place*, though, of course, after the effluent gas is once free from the orifice it may change its temperature in time.

We assume the pressure p_m (in throat of jet) to be equal to that of the outside medium (as was done with flow of water), so long as that outside tension is greater than $.527 p_n$; but if it is less than $.527 p_n$ and is even zero (a vacuum), experiment seems to show that p_m remains equal to 0.527 of the interior tension p_n : probably on account of the expansion of the effluent gas beyond the throat, Fig. 620, so that although the tension in the outer edge, at a , of the jet is equal to that of the outside medium, the tension at m is greater because of the centripetal and centrifugal forces developed in the curved filaments between a and m .

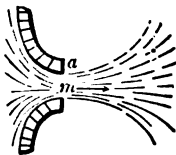

FIG. 620.

m. (See § 553.)

550. Flow through an Orifice; Heaviness assumed Constant during Flow. The Water Formula.—If the inner tension p_n ex-

ceeds the outer, p_m , but slightly, we may assume that, like water, the gas remains of the same heaviness during flow. Then, for the simultaneous advance made by all the laminae of a stream-line, Fig. 619, in the time dt , we may conceive an equation like eq. (A) written out for each lamina between n and m , and corresponding terms added; i.e.,

$$(For\ orifices) \dots \frac{1}{g} \int_n^m v dv + \int_n^m dz + \int_n^m \frac{dp}{\gamma} = 0. \dots (B)$$

In general, γ is different in the different laminae, but in the present case it is assumed to be the same in all; hence, with m as datum level and $h =$ vertical distance from n to m , we have, from eq. (B),

$$\frac{v_m^2}{2g} - \frac{v_n^2}{2g} + 0 - h + \frac{p_m}{\gamma} - \frac{p_n}{\gamma} = 0. \dots (1)$$

But we may put $v_n = 0$; while h , even if several feet, is small compared with $\frac{p_n}{\gamma} - \frac{p_m}{\gamma}$. E.g., with $p_m = 15$ lbs. per sq. in. and $p_n = 16$ lbs. per sq. in., we have for atmospheric air at freezing temperature

$$\frac{p_n}{\gamma} - \frac{p_m}{\gamma} = 1638 \text{ feet.}$$

Hence, putting $v_n = 0$ and $h = 0$ in eq. (1), we have

$$\frac{v_m^2}{2g} = \frac{p_n - p_m}{\gamma_n} \dots \left\{ \begin{array}{l} \text{Water formula; for small} \\ \text{difference of pressures, only.} \end{array} \right\} \dots (2)$$

The interior absolute temperature T_n being known, the γ_n (interior heaviness) may be obtained from $\gamma_n = p_n \gamma_o T_o \div T_n p_o$ (§ 472), and the volume of flow per unit of time then obtained (first solving (2) for v_m) is

$$Q_m = F_m v_m, \dots (3)$$

where F_m is the sectional area of the jet at m . If the mouth-piece or orifice has well-rounded interior edges, as in Fig. 541,

its sectional area F may be taken as the area F_m . But if it is an orifice in "thin plate," putting the coefficient of contraction $= C = 0.60$, we have

$$F_m = CF = 0.60 F; \text{ and } Q_m = 0.60 Fv_m. \quad (4)$$

This volume, Q_m , is that occupied by the flow per time-unit when in *state m*, and we have assumed that $\gamma_m = \gamma_n$; hence the *weight of flow* per time-unit is

$$G = Q_m\gamma_m = F_mv_m\gamma_m = F_mv_m\gamma_n. \quad (5)$$

EXAMPLE.—In the testing of a blowing-engine it is found capable of maintaining a pressure of 18 lbs. per sq. inch in a large receiver, from whose side a blast is steadily escaping through a "thin plate" orifice (circular) having an area $F = 4$ sq. inches. The interior temperature is 30° Cent. and the outside tension 15 lbs. per sq. in.

Required the discharge of air per second, both volume and weight. The data are: $p_n = 18$ lbs. per sq. in., $T_n = 303^\circ$ Abs. Cent., $F = 4$ sq. inches, and $p_m = 15$ lbs. per sq. in. Use ft.-lb.-sec. system.

First, the heaviness in the receiver is

$$\gamma_n = \frac{p_n}{p_o} \cdot \frac{T_o}{T_n} \gamma_o = \frac{18}{14.7} \cdot \frac{273}{303} \times .0807 = .089 \text{ lbs. per cub. ft.}$$

Then, from eq. (2),

$$v_m = \sqrt{2g \frac{p_n - p_m}{\gamma_n}} = \sqrt{\frac{2 \times 32.2 [144 \times 18 - 144 \times 15]}{0.089}} = \left\{ \begin{array}{l} 555.3 \\ \text{feet} \\ \text{per sec.} \end{array} \right.$$

(97 per cent of this would be more correct on account of friction.)

$$\therefore Q_m = F_mv_m = .6Fv_m = \frac{6}{10} \cdot \frac{4}{144} \times 555.3 = 9.24 \text{ cub. ft. per sec.}$$

at a tension of 15 lbs. per sq. in., and of heaviness (by hypothesis) $= .089$ lbs. per cub. ft. Hence weight

$$= G = 9.24 \times .089 = .82 \text{ lbs. per sec.}$$

The theoretical *power* of the air-compressor or blowing-engine to maintain this steady flow can be computed as in Example 3, § 483.

551. Flow through an Orifice on the Basis of Mariotte's Law; or Isothermal Efflux.—Since in reality the gas expands during flow through an orifice, and hence changes its heaviness (Fig. 619), we approximate more nearly to the truth in assuming this change of density to follow Mariotte's law, i.e., that the *heaviness varies directly as the pressure*, and thus imply that the *temperature remains unchanged during the flow*. We again integrate the terms of eq. (B), but take care to note that, *now*, γ is variable (i.e., different in different laminae at the same instant), and hence express it in terms of the variable p (from eq. (2), § 475), thus:

$$\gamma = (\gamma_n \div p_n)p.$$

Therefore the term $\int_n^m \frac{dp}{\gamma}$ of eq. (B) becomes

$$\frac{p_n}{\gamma_n} \int_n^m \frac{dp}{p} = -\frac{p_n}{\gamma_n} \log_e \frac{p_n}{p_m}, \dots \dots (1)$$

and, integrating all the terms of eq. (B), neglecting h , and calling v_n zero, we have

$$\frac{v_m^2}{2g} = \frac{p_n}{\gamma_n} \log_e \frac{p_n}{p_m} \dots \dots \left\{ \begin{array}{l} \text{efflux by Mariotte's} \\ \text{Law through orifice} \end{array} \right\} \dots \dots (2)$$

As before, $\gamma_n = \frac{T_o}{T_n} \cdot \frac{p_n}{p_o} \gamma_o$, and the flow of volume per time-unit at m is

$$Q_m = F_m v_m; \dots \dots \dots (3)$$

while if the orifice is in thin plate, F_m may be put = .60 F , and the

$$\text{weight of the flow per time-unit} = G = F_m v_m \gamma_m. \dots (4)$$

If the mouth-piece is rounded, $F_m = F =$ area of exit orifice of mouth-piece.

EXAMPLE.—Applying eq. (2) to the data of the example in § 550, where γ_n was found to be .089 lbs. per cub. ft., we have [ft., lb., sec.]

$$v_m = \sqrt{2g \frac{p_n}{\gamma_n} \log_e \frac{p_n}{p_m}}$$

$$= \sqrt{2 \times 32.2 \times \frac{18 \times 144}{.089} \times 2.3025 \times \log_{10} \left[\frac{18}{15} \right]} = 584.7 \text{ ft. p. sec.}$$

$$\therefore Q_m = F_m v_m = 0.60 \times \frac{4}{144} \times 584.7 = 9.745 \text{ cub. ft. per sec.}$$

Since the heaviness at m is, from Mariotte's law,

$$\gamma_m = \frac{p_m}{p_n} \gamma_n = \frac{1}{1\frac{1}{5}} \text{ of } .089, \text{ i.e., } \gamma_m = .0741 \text{ lbs. per cub. ft.,}$$

hence the weight of the discharge is

$$G = Q_m \gamma_m = 9.745 \times .0741 = 0.722 \text{ lbs. per sec.,}$$

or about 12 per cent less than that given by the "water formula." If the difference between the inner and outer tensions had been less, the discrepancy between the results of the two methods would not have been so marked.

552. Adiabatic Efflux from an Orifice.—It is most logical to assume that the expansion of the gas approaching the orifice, being rapid, is *adiabatic* (§ 478). Hence (especially when the difference between the inner and outer tensions is considerable) it is more accurate to assume γ as varying according to Poisson's Law, eq. (1), § 478; i.e., $\gamma = [\gamma_n \div p_n^{\frac{1}{n}}] p^{\frac{1}{n}}$, in integrating eq. (B). Then the term

$$\int_n^m \frac{dp}{\gamma} \text{ will } = \frac{p_n^{\frac{1}{n}}}{\gamma_n} \int_n^m p^{-\frac{1}{n}} dp = \frac{3p_n^{\frac{1}{n}}}{\gamma_n} [p_m^{\frac{2}{3}} - p_n^{\frac{2}{3}}]$$

$$= -\frac{3p_n}{\gamma_n} \left[1 - \left(\frac{p_m}{p_n} \right)^{\frac{2}{3}} \right];$$

and eq. (B), neglecting h as before, and with $v_n = 0$, becomes (See Fig. 619)

$$\frac{v_m^2}{2g} = \frac{3p_n}{\gamma_n} \left[1 - \left(\frac{p_m}{p_n} \right)^{\frac{2}{\gamma_n}} \right]. \text{ (Adiabatic flow; orifice.) } \quad (1)$$

Having observed p_n and T_n in the reservoir, we compute $\gamma_n = \frac{p_n \gamma_0 T_0}{T_n p_0}$ (from § 472). The gas at m , just leaving the orifice, having expanded adiabatically from the *state n* to the *state m*, has cooled to a temperature T_m (absolute) found thus (§ 478),

$$T_m = T_n \left(\frac{p_m}{p_n} \right)^{\frac{1}{\gamma_n}}, \quad \dots \dots \dots (2)$$

and is of a heaviness

$$\nu_m = \gamma_n \left(\frac{p_m}{p_n} \right)^{\frac{1}{\gamma_n}}, \quad \dots \dots \dots (3)$$

and the flow per second occupies a volume (immediately on exit)

$$Q_m = F_m v_m, \quad \dots \dots \dots (4)$$

and weighs

$$G = F_m v_m \gamma_m. \quad \dots \dots \dots (5)$$

EXAMPLE 1.—Let the interior conditions in the large reservoir of Fig. 619 be as follows (*state n*): $p_n = 22\frac{1}{2}$ lbs. per sq. in., and $T_n = 294^\circ$ Abs. Cent. (i.e., 21° Cent.); while externally the tension is 15 lbs. per sq. inch, which may be taken as being $= p_m =$ tension at m , the throat of jet. The opening is a circular orifice in “thin plate” and of one inch diameter. Required the weight of the discharge per second [ft., lb., sec.; $g = 32.2$].

First, $\gamma_n = \frac{22.5 \times 144}{15 \times 144} \cdot \frac{273}{294} \times .0807 = 0.114$ lbs. per cub. ft.

Then, from (1),

$$\begin{aligned} v_m &= \sqrt{2g \frac{3p_n}{\gamma_n} \left[1 - \left(\frac{p_m}{p_n} \right)^{\frac{2}{\gamma_n}} \right]} \\ &= \sqrt{\frac{2 \times 32.2 \times 3 \times 22.5 \times 144}{0.114} \left[1 - \sqrt[2]{\frac{2}{3}} \right]} = 844 \text{ ft. per sec.} \end{aligned}$$

Now $F = \frac{1}{4}\pi\left(\frac{1}{12}\right)^2 = .00546$ sq. ft.

$$\therefore Q_m = CFv_m = .60Fv_m = 0.60 \times .00546 \times 844 = 2.765$$

cub. ft. per sec., at a temperature of

$$T_m = 294 \sqrt{\frac{3}{8}} = 257^\circ \text{ Abs. Cent.} = -16^\circ \text{ Cent.},$$

and of a heaviness

$$\gamma_m = 0.114 \sqrt{\left(\frac{3}{8}\right)^2} = 0.085 \text{ lbs. per cub. ft.},$$

so that the weight of flow per sec.

$$= G = Q_m \gamma_m = 2.765 \times .085 = .235 \text{ lbs. per sec.}$$

EXAMPLE 2.—Let us treat the example already solved by the two preceding approximate methods (§§ 550 and 551) by the present more accurate equation of adiabatic flow, eq. (1).

The data were (Fig. 619):

$$p_n = 18 \text{ lbs. per sq. in.}; T_n = 303^\circ \text{ Abs. Cent.};$$

$$p_m = 15 \text{ " " "}; \text{ and } F = 4 \text{ sq. inches}$$

[F being the area of orifice]. γ_n was found = .089 lbs. per cub. ft. in § 550; hence, from eq. (1),

$$v_m = \sqrt{\frac{2 \times 32.2 \times 3 \times 18 \times 144}{.089} [1 - \sqrt{\frac{3}{8}}]} = 576.2 \text{ ft. per sec.}$$

From (4),

$$Q_m = F_m v_m = .6Fv_m = .6 \times \frac{4}{144} \times 576.2 = 9.603 \text{ cub. ft. per sec.};$$

and since at m it is of a heaviness

$$\gamma_m = .089 \sqrt{\left(\frac{15}{18}\right)^2} = .0788 \text{ lbs. per cub. ft.},$$

we have weight of flow per sec.

$$= G = Q_m \gamma_m = 9.603 \times .0788 = 0.756 \text{ lbs. per sec.}$$

Comparing the three methods for this problem, we see that

By the "water formula," . . . $G = 0.82$ lbs. per sec.
 " isothermal formula, . . . $G = 0.722$ " "
 " adiabatic formula, . . . $G = 0.756$ " "

553. Practical Notes. Theoretical Maximum Flow of Weight.
 —If in the equations of § 552 we write for brevity $p_m \div p_n = x$ we derive, by substitution from (1) and (3) in (5),

$$\left. \begin{array}{l} \text{Weight of flow} \\ \text{per unit of time} \end{array} \right\} = G = Q_m \gamma_m = F_m \sqrt{6gp_n \gamma_n} [1 - x^2]^{\frac{1}{2}} x^3. \quad (1)$$

This function of x is of such a form as to be a maximum for

$$x = (p_m \div p_n) = \left(\frac{1}{2}\right)^{\frac{2}{3}} = .512; \quad (2)$$

i.e., theoretically, if the *state n* inside the reservoir remains the same, while the outside tension (considered = p_m of jet, Fig. 619) is made to assume lower and lower values (so that $x = p_m \div p_n$, diminishes in the same ratio), the maximum flow of weight per unit of time will occur when $p_m = .512 p_n$, a little more than half the inside tension. (With the more accurate value 1.41 (1.408), instead of $\frac{1}{2}$, see § 478, we should obtain .527 instead of .512 for dry air; see § 549.)

Prof. Cotterill says (p. 544 of his "Applied Mechanics"): "The diminution of the theoretical discharge on diminution of the external pressure below the limit just now given is an anomaly which had always been considered as requiring explanation, and M. St. Venant had already suggested that it could not actually occur. In 1866 Mr. R. D. Napier showed by experiment that the weight of steam of given pressure discharged from an orifice really is independent of the pressure of the medium into which efflux takes place* ; and in 1872 Mr. Wilson confirmed this result by experiments on the reaction of steam issuing from an orifice."

"The explanation lies in the fact that the pressure in the

* When the difference between internal and external pressures is great,—should be added.

centre of the contracted jet is not the same as that of the surrounding medium. The jet after passing the contracted section suddenly expands, and the change of direction of the fluid particles gives rise to centrifugal forces" which cause the pressures to be greater in the centre of the contracted section than at the circumference; see Fig. 620.

Prof. Cotterill then advises the assumption that $p_m = .527 p_n$ (for air and perfect gases) as the mean tension in the jet at m (Fig. 619), *whenever the outside medium is at a tension less than .527 p_n* . He also says, "Contraction and friction must be allowed for by the use of a coefficient of discharge the value of which, however, is more variable than that of the corresponding coefficient for an incompressible fluid. Little is certainly known on this point." See §§ 549 and 554.

For air the velocity of this *maximum flow of weight* is

$$\text{Vel. of max. } G = \left[997 \sqrt{\frac{T_n}{T_o}} \right] \text{ ft. per sec., . (3)}$$

where T_n = abs. temp. in reservoir, and T_o = that of freezing point. Rankine's Applied Mechanics (p. 584) mentions experiments of Drs. Joule and Thomson, in which the circular orifices were in a thin plate of copper and of diameters 0.029 in., 0.053 in., and 0.084 in., while the outside tension was about one half of that inside. The results were 84 per cent of those demanded by theory, a discrepancy due mainly, as Rankine says, to the fact that the actual area of the orifice was used in computation instead of the contracted section; i.e., contraction was neglected.

554. Coefficients of Efflux by Experiment. For Orifices and Short Pipes. Small Difference of Tensions.—Since the discharge through an orifice or short pipe from a reservoir is affected not only by contraction, but by slight friction at the edges, even with a rounded entrance, the theoretical results for the volume and weight of flow per unit of time in preceding paragraphs should be multiplied both by a coefficient of velocity ϕ and one for contraction C , as in the case of water; i.e., by a *coefficient of efflux* μ , = ϕC . (Of course, when there is no

contraction, $C = 1.00$, and then $\mu = \phi$ as with a well-rounded mouth-piece, for instance, Fig. 541, and with short pipes.)

Hence for practical results, with orifices and short pipes, we should write for the *weight of flow per unit of time*

$$= G = \mu F v_m \gamma_m = \mu F \left(\frac{p_m}{p_n}\right)^{\frac{1}{2}} \sqrt{2g \beta p_n \gamma_n \left[1 - \left(\frac{p_m}{p_n}\right)^{\frac{1}{2}}\right]} \quad (1)$$

(from the equations of § 552 for adiabatic flow, as most accurate; $p_m \div p_n$ may range from $\frac{1}{2}$ to 1.00). F = area of orifice, or of discharging end of mouth-piece or short pipe. γ_n = heaviness of air in reservoir and = $T_n p_n \gamma_o \div T_o p_o$, eq. (13) of § 437; and μ = the experimental coefficient of efflux.

From his own experiments and those of Koch, D'Aubuisson, and others, Weisbach recommends the following mean values of μ for various mouthpieces, when p_n is not more than $\frac{1}{2}$ larger than p_m (i.e., about 17 % larger), for use in eq. (1):

1. For an orifice in a thin plate, $\mu = 0.56$
2. For a short cylindrical pipe (inner corners not rounded), $\mu = 0.75$
3. For a well-rounded mouth-piece (like that in Fig. 541), $\mu = 0.98$
4. For a short conical convergent pipe (angle about 6°), $\mu = 0.92$

EXAMPLE.—(Data from Weisbach's Mechanics.) "If the sum of the areas of two conical tuyères of a blowing-machine is $F = 3$ sq. inches, the temperature in the reservoir 15° Cent., the height of the attached (open) mercury manometer (see Fig. 464) 3 inches, and the height of the barometer in the external air 29 inches," we have (ft., lb., sec.)

$$\frac{p_m}{p_n} = \frac{29}{29 + 3} = \frac{29}{32}; \quad T_n = 288^\circ \text{ Abs. Cent.};$$

$$p_n = \left(\frac{3}{4}\right) 14.7 \times 144 \text{ lbs. per sq. ft.};$$

$$\gamma_n = \frac{3}{4} \cdot \frac{3}{4} \times 0.0807 = 0.0816 \text{ lbs. per cub. ft.},$$

while $F = \frac{3}{144}$ sq. ft. and (see above) $\mu = 0.92$; hence

$$G = 0.92 \times \frac{3}{144} \left(\frac{3}{4}\right)^{\frac{1}{2}} \sqrt{2 \times 32.2 \times 3 \times \frac{3}{4} \times 14.7 \times 144 \times 0.0816 \left[1 - \sqrt{\frac{3}{4}}\right]}$$

i.e., $G = .6076$ lbs. per second; which will occupy a volume

$$V_0 = G \div \gamma_0 = G \div .0807 = 7.59 \text{ cub. ft.}$$

at one atmosphere tension and freezing-point temperature, while at a temperature of $T_n = 288^\circ$ Abs. Cent. and tension of $p_n = \frac{3}{2}$ of one atmosphere (i.e., in the state in which it was on entering the blowing-engine) it occupied a volume

$$V = \frac{3}{2} \cdot \frac{2}{3} \times 7.59 = 8.24 \text{ cub. ft.}$$

(This last is Weisbach's result, obtained by an approximate formula.)

555. Coefficients of Efflux for Orifices and Short Pipes for a Large Difference of Tension.—For values $> \frac{1}{2}$ and < 2 , of the ratio $p_n : p_m$, of internal to external tension, Weisbach's experiments with *circular orifices in thin plate*, of diameters ($= d$) from 0.4 inches to 0.8 inches, gave the following results:

$p_n : p_m =$	1.05	1.09	1.40	1.65	1.90	2.00
for $d = .4^{\text{in.}}; \mu =$.55	.59	.69	.73	.76	.78
" $d = .8^{\text{in.}}; \mu =$.56	.57	.64	.68		.73

Whence it appears that μ increases somewhat with the ratio of p_n to p_m , and decreases slightly for increasing size of orifice.

With short cylindrical pipes, internal edges not rounded, and three times as long as wide, Weisbach obtained μ as follows:

$p_n : p_m =$	1.05	1.10	1.30	1.40	1.70	1.74
diam. $= .4^{\text{in.}}; \mu =$.78	.77	.93			
" $= .6^{\text{in.}}; \mu =$.81	.83	
" $= 1.0^{\text{in.}}; \mu =$.83

When the inner edges of the 0.4 in. pipe were slightly rounded, μ was found $= 0.93$; while a well-rounded mouth-piece of the form shown in Fig. 541 gave a value $\mu =$ from .965 to .968, for $p_n : p_m$ ranging from 1.25 to 2.00. These values of μ are for use in eq. (1), above.

556. To find the Discharge when the Internal Pressure is measured in a Small Reservoir or Pipe, not much larger than the

Orifice.—Fig. 621. If the internal pressure p_n , and temperature T_n , must be measured in a small reservoir or pipe, n , whose sectional area F_n is not very large compared with that of the orifice, F , (or of the jet, F_m), the velocity v_n at n (velocity of approach) cannot be put = zero. Hence, in applying eq. (B), § 550, to the successive laminae between n and m , and integrating, we shall have, for *adiabatic steady flow*,

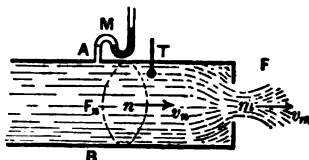

FIG. 621.

$$\frac{v_m^2}{2g} - \frac{v_n^2}{2g} = \frac{3p_n}{\gamma_n} \left[1 - \left(\frac{p_m}{p_n} \right)^{\frac{1}{\gamma}} \right] \dots \dots (1)$$

instead of eq. (1) of § 552. But from the equation of continuity for steady flow of gases [eq. (a) of § 548], $F_n v_n \gamma_n = F_m v_m \gamma_m$; hence $v_n^2 = \frac{F_m^2 \gamma_m^2}{F_n^2 \gamma_n^2} v_m^2$, while for an adiabatic change from n to m , $\frac{\gamma_m}{\gamma_n} = \left(\frac{p_m}{p_n} \right)^{\frac{1}{\gamma}}$; whence by substitution in (1), solving for v_m , we have

$$v_m = \frac{\sqrt{2g \cdot \frac{3p_n}{\gamma_n} \left[1 - \left(\frac{p_m}{p_n} \right)^{\frac{1}{\gamma}} \right]}}{\sqrt{1 - \left(\frac{F_m}{F_n} \right)^2 \left(\frac{p_m}{p_n} \right)^{\frac{1}{\gamma}}}} \dots \dots (2)$$

As before, from §§ 472 and 478,

$$\gamma_n = \frac{p_n T_0}{p_0 T_n} \cdot \gamma_0 \dots \dots (3)$$

and

$$\gamma_m = \left(\frac{p_m}{p_n} \right)^{\frac{1}{\gamma}} \gamma_n \dots \dots (4)$$

Having observed p_n , p_m , and T_n , then, and knowing the area F of the orifice, we may compute γ_n , γ_m , and v_m , and finally the

$$\text{Weight of flow per time-unit} = G = \mu F v_m \gamma_m, \dots (5)$$

taking μ from § 554 or 555. In eq. (2) it must be remembered that for an orifice in "thin plate," F_m is the sectional area of the *contracted vein*, and = CF ; where C may be put = $\frac{\mu}{.97}$.

EXAMPLE.—If the diameter of AB , Fig. 621, is $3\frac{1}{2}$ inches, and that of the orifice, well rounded, = 2 in.; if $p_n = 1\frac{1}{2}$ atmospheres = $\frac{1}{2} \times 14.7 \times 144$ lbs. per sq. ft., while $p_m = \frac{1}{2}$ of an atmos., so that $\frac{p_m}{p_n} = \frac{1}{3}$, and $T_n = 283^\circ$ Abs. Cent.,—required the discharge per second, using the ft., lb., and sec.

From eq. (3),

$$\gamma_n = \frac{1}{2} \cdot \frac{14.7}{32.2} \times 0.0807 = .08433 \text{ lbs. per cub. ft.};$$

whence (eq. (4))

$$\gamma_m = \left(\frac{1}{3}\right)^3 \gamma_n = .07544 \text{ lbs. per cub. ft.}$$

Then, from eq. (2),

$$v_m = \left[\sqrt{\frac{64.4 \times 3 \times 15.925 \times 144}{.08433} \left(1 - \left(\frac{1}{3}\right)^3\right)} \right] \div \left[\sqrt{1 - \left(\frac{1}{3}\right)^3 \left(\frac{1}{3}\right)^3} \right]$$

$$= 558.1 \text{ ft. per sec.};$$

$$\therefore G = 0.98 \frac{\pi \left(\frac{1}{6}\right)^2}{4} 558.1 \times .07544 = .9003 \text{ lbs. per sec.}$$

557. Transmission of Compressed Air; through very Long Level Pipes. Steady Flow.

CASE I. When the difference between the tensions in the reservoirs at the ends of the pipe is small.—Fig. 622. Under

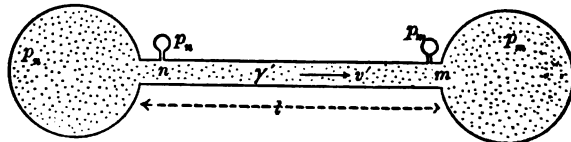

FIG. 622.

these circumstances it is simpler to employ the form of formula that would be obtained for a liquid by applying Bernoulli's Theorem, taking into account the "loss of head" occasioned

by the friction on the sides of the pipe. Since the pipe is very long, and the change of pressure small, the mean velocity in the pipe, v' , assumed to be nearly the same at all points along the pipe, will not be large; hence the difference between the velocity-heads at n and m will be neglected; a certain *mean heaviness* γ' will be assigned to all the gas in the pipe, as if a liquid.

Applying Bernoulli's Theorem, *with friction*, § 516, to the ends of the pipe, n and m , we have (as for a liquid)

$$\frac{v_m^2}{2g} + \frac{p_m}{\gamma'} + 0 = \frac{v_n^2}{2g} + \frac{p_n}{\gamma'} + 0 - 4f \frac{l}{d} \frac{v'^2}{2g} \quad (1)$$

Putting (as above mentioned) $v_m^2 - v_n^2 = 0$, we have, more simply,

$$\frac{p_n - p_m}{\gamma'} = 4f \frac{l}{d} \frac{v'^2}{2g} \quad \dots \dots \dots (2)$$

The value of f as *coefficient of friction for air in long pipes* is found to be somewhat smaller than for water; see next paragraph.

558. Transmission of Compressed Air. Experiments in the St. Gothard Tunnel, 1878.—[See p. 96 of Vol. 24 (Feb. '81), Van Nostrand's Engineering Magazine.] In these experiments, the temperature and pressure of the flowing gas (air) were observed at each end of a long portion of the pipe which delivered the compressed air to the boring-machines three miles distant from the tunnel's mouth. The portion considered was selected at a distance from the entrance of the tunnel, to eliminate the fluctuating influence of the weather on the temperature of the flowing air. A *steady flow* being secured by proper regulation of the compressors and distributing tubes, observations were made of the internal pressure (p), internal temperature (T), as well as the external, at each end of the portion of pipe considered, and also at intermediate points; also of the *weight of flow per second* $G = Q\gamma$, measured at the compressors under standard conditions (0° Cent. and one atmos. tension). Then knowing the p and T at any section of the pipe, the

heaviness γ of the air passing that section can be computed [from $\frac{\gamma}{\gamma_0} = \frac{p}{p_0} \cdot \frac{T_0}{T}$] and the velocity $v = G \div F\gamma$, F being the sectional area at that point. Hence the *mean velocity* v' , and the *mean heaviness* γ' , can be computed for this portion of the pipe whose diameter = d and length = l . In the experiments cited it was found that at points not too near the tunnel-mouth the temperature inside the pipe was always about 3° Cent. lower than that of the tunnel. The values of f in the different experiments were then computed from eq. (2) of the last paragraph; i.e.,

$$\frac{p_n - p_m}{\gamma'} = 4f \frac{l}{d} \cdot \frac{v'^2}{2g}, \dots \dots \dots (2)$$

all the other quantities having been either directly observed, or computed from observed quantities.

THE ST. GOTHARD EXPERIMENTS.

[Concrete quantities reduced to English units.]

No.	l (feet.)	d (ft.)	γ (lbs. cub. ft.)	Atmospheres.		$p_n - p_m$ lbs. sq. in.	v' ft. per sec.	mean temp. Cent.	f
				p_n	p_m				
1	15092	½	0.4058	5.60	5.24	5.29	19.32	21°	.0085
2	15092	½	0.3209	4.85	4.13	3.28	16.80	21°	.0088
3	15092	½	.2803	3.84	3.65	2.79	15.55	21°	.0041
4	1712	½	.3765	5.24	5.00	3.52	37.13	26.5	.0045
5	1712	½	.3009	4.13	4.06	1.03	30.82	26.5	.0024(?)
6	1712	½	.2641	3.65	3.54	1.54	29.34	26.5	.0045

In the article referred to (Van Nostrand's Mag.) f is not computed. The writer contents himself with showing that Weisbach's values (based on experiments with small pipes and high velocities) are much too great for the pipes in use in the tunnel.

With small tubes an inch or less in diameter Weisbach found, for a velocity of about 80 ft. per second, $f = .0060$; for still higher velocities f was smaller, approximately, in accordance with the relation

$$f = \frac{.0542}{\sqrt{v' \text{ (in ft. per sec.)}}}$$

On p. 370, vol. xxiv, Van Nostrand's Mag., Prof. Robinson of Ohio mentions other experiments with large long pipes.

From the St. Gothard experiments a value of $f = .004$ may be inferred for approximate results with pipes from 3 to 8 in. in diameter.

EXAMPLE.—It is required to transmit, in steady flow, a supply of $G = 6.456$ lbs. of atmospheric air per second through a pipe 30000 ft. in length (nearly six miles) from a reservoir where the tension is 6.0 atmos. to another where it is 5.8 atmos., the mean temperature in the pipe being 80° Fahr., = 24° Cent. (i.e. = 297° Abs. Cent.). Required the proper diameter of pipe; $d = ?$ The value $f = .00425$ will be used, and the ft.-lb.-sec. system of units. The mean volume passing per second in the pipe is

$$Q' = G \div \gamma' \dots \dots \dots (3)$$

The mean velocity may thus be written: $v' = \frac{Q'}{F} = \frac{Q'}{\frac{1}{4}\pi d^2}$. (4)

The mean heaviness of the flowing air, computed for a mean tension of 5.9 atmospheres, is, by § 472,

$$\gamma' = \frac{5.9 \times 14.7}{1 \times 14.7} \cdot \frac{273}{297} \times .0807 = 0.431 \text{ lbs. per cub. ft. ;}$$

and hence, see eq. (3),

$$Q' = \frac{G}{\gamma'} = \frac{6.456}{0.431} = 14.74 \text{ cub. ft.}$$

at tension of 5.9 atmos., and temperature 297° Abs. Cent.

Now, from eq. (2),

$$\frac{p_n - p_m}{\gamma'} = \frac{4f}{2g} \cdot \frac{l}{d} \cdot \left[\frac{Q'}{\frac{1}{4}\pi d^2} \right]^2 ;$$

whence

$$d^5 = \frac{4f}{(\frac{1}{4}\pi)^2} \cdot \frac{\gamma' l}{(p_n - p_m)} \cdot \frac{Q'^2}{2g} ; \dots \dots \dots (5)$$

and hence, numerically,

$$d = \sqrt[5]{\frac{4 \times .00425 \times 0.431 \times 30000 \times (14.74)^3}{(.7854)^3 [14.7 \times 144(6.00 - 5.80)] 2 \times 32.2}} = 1.23 \text{ feet.}$$

559. (Case II of § 557) Long Pipe, with Considerable Difference of Pressure at Extremities of the Pipe. Flow Steady.—Fig. 623. If the difference between the end-tensions is comparatively *great*, we can no longer deal with the whole of the air

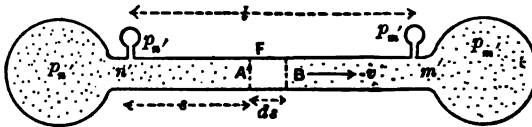

FIG. 623.

in the pipe at once, as regards ascribing to it a mean velocity and mean tension, but *must consider the separate laminæ*, such as *AB* (a short length of the air-stream) to which we may apply eq. (2) of § 557; *A* and *B* corresponding to the *n* and *m* of Fig. 622. Since the $p_n - p_m$, l , γ' , and v' of § 557 correspond to the $-dp$, ds , γ , and v of the present case (short section or lamina), we may write

$$-\frac{dp}{\gamma} = 4f \frac{v^3}{d 2g} ds. \quad \dots \quad (1)$$

But if G = weight of flow per unit of time, we have at any section, $Fv\gamma = G$ (equation of continuity); i.e., $v = G \div F\gamma$, whence by substitution in eq. (1) we have

$$-\frac{dp}{\gamma} = \frac{4f}{2gd} \cdot \frac{G^3 ds}{F^3 \gamma^3}; \quad \text{i.e.,} \quad -\gamma dp = \frac{4fG^3}{2gF^3 d} ds. \quad \dots \quad (2)$$

Eq. (2) contains *three variables*, γ , p , and s (= distance of lamina from n'). As to the dependence of the heaviness γ on the tension p in different laminæ, experiment shows that in most cases a uniform temperature is found to exist all along the pipe, if properly buried, or shaded from the sun; the loss of heat by adiabatic expansion being in great part made up by the heat generated by the friction against the walls of the

pipe. This is due to the small loss of tension per unit of length of pipe as compared with that occurring in a short discharge pipe or nozzle. Hence we may treat the flow as *isothermal*, and write $p \div \gamma = p_{n'} \div \gamma_{n'}$ (§ 475, Mariotte's Law).

Hence $\gamma = \frac{\gamma_{n'}}{p_{n'}} p$, which substituted in eq. (2) enables us to

write:

$$-pdp = \left[\frac{4fG^2}{2gF^2d} \frac{p_{n'}}{\gamma_{n'}} \right] ds. \dots \dots (3)'$$

$$\therefore - \int_{n'}^{m'} p dp = \left[\frac{4fG^2 p_{n'}}{2gF^2 \gamma_{n'} d} \right] \int_0^l ds. \dots \dots (3)$$

Performing the integration, noting that at n' $p = p_{n'}$, $s = 0$, and at m' $p = p_{m'}$ and $s = l$, we have

$$\frac{1}{2} [p_{n'}^2 - p_{m'}^2] = \frac{4fl}{2gd} \cdot \frac{G^2}{F^2} \cdot \frac{p_{n'}}{\gamma_{n'}} \cdot \left\{ \begin{array}{l} \text{isothermal flow} \\ \text{in long pipes} \end{array} \right\} \dots (4)$$

It is here assumed that the tension at the entrance of the pipe is practically equal to that in the head reservoir, and that at the end (m') to that of the receiving reservoir; which is not strictly true, especially when the corners are not rounded. It will be remembered also that in establishing eq. (2) of § 557 (the basis of the present paragraph), the "inertia" of the gas was neglected; i.e., the change of velocity in passing along the pipe. Hence eq. (4) should not be applied to cases where the pipe is so short, or the difference of end-tensions so great, as to create a considerable difference between the velocities at the two ends of the pipe. (See Addendum on p. 797.)

EXAMPLE.—A well or reservoir supplies natural gas at a tension of $p_{n'} = 30$ lbs. per sq. inch. Its heaviness at 0° Cent. and one atmosphere tension is .0484 lbs. per cub. foot. In piping this gas along a level to a town two miles distant, a single four-inch pipe is to be employed, and the tension in the receiving reservoir (by proper regulation of the gas distributed from it) is to be kept equal to 16 lbs. per sq. in. (which would sustain a column of water about 2 ft. in height in an *open* water manometer, Fig. 465).

The mean temperature in the pipe being 17° Cent., required the amount (weight) of gas delivered per second, supposing leakage to be prevented (formerly a difficult matter in practice). Solve (4) for G , and we have

$$G = \frac{1}{4}\pi d^2 \sqrt{\frac{gd}{4fl} \cdot \frac{\gamma_n'}{p_n'} (p_n'^2 - p_m'^2)}. \quad \dots \quad (5)$$

First, from § 472, with $T_n' = T_m' = 290^\circ$ Abs. Cent., we compute

$$\frac{p_n'}{\gamma_n'} = \frac{p_o}{\gamma_o} \cdot \frac{T_n'}{T_o} = \frac{14.7 \times 144}{.0484} \cdot \frac{290}{273} = 46454 \text{ feet.}$$

Hence with $f = .005$,

$$G = \frac{1}{4}\pi \left(\frac{4}{12}\right)^2 \cdot \sqrt{\frac{32.2 \times \frac{4}{12} [(30 \times 144)^2 - (16 \times 144)^2]}{4 \times .005 \times 10560 \times 46454}}$$

$$= 0.337 \text{ lbs. per sec.}$$

(For compressed atmospheric air, under like conditions, we would have $G = 0.430$ lbs. per second.)

Of course the proper choice of the coefficient f has an important influence on the result.

From the above result ($G = 0.337$ lbs. per second) we can compute the volume occupied by this quantity of gas in the receiving reservoir, using the relation $Q_{m'} = \frac{G}{\gamma_{m'}}$.

The heaviness $\gamma_{m'}$ of the gas in the receiving reservoir is most easily found from the relation $\frac{p_{m'}}{\gamma_{m'}} = \frac{p_n'}{\gamma_n'}$, which holds good since the flow is *isothermal*. I.e., $\frac{p_{m'}}{\gamma_{m'}} = 46454$ ft.; whence $\gamma_{m'} = 0.049$ lbs. per cubic foot, $p_{m'}$ being 16×144 lbs. per sq. ft.

Hence

$$Q_{m'} = \frac{G}{\gamma_{m'}} = \frac{0.337}{0.049} = 6.794 \text{ cub. ft. per sec.}$$

It should be said that the pressure at the up-stream end of the pipe depends upon the rate of flow allowed to take place.

With no flow permitted, the pressure in the tube of a gas-well has in some cases reached the high figure of 500 or 600 lbs. per sq. in.

560. Rate of Decrease of Pressure along a Long Pipe.—Considering further the case of the last paragraph, that of a straight, long, level pipe of uniform diameter, delivering gas from a storage reservoir into a receiving reservoir, we note that if in eq. (4) we retain p_m' to indicate the tension in the receiving reservoir, but let p_n' denote in turn the tension at points in the pipe successively further and further (a distance x) from the receiving reservoir m' , we may write x for l and obtain the equation (between two variables, p_n' and x)

$$p_n'^2 - p_m'^2 = \text{Const.} \times x. \dots \dots (6)$$

This can be used to bring out an interesting relation mentioned by a writer in the *Engineering News* of July 1887 (p. 71), viz., the fact that in the parts of the pipe more distant from the receiving end, m' , the distance along the pipe in which a given loss of pressure occurs is much greater than near the receiving end.

To make a numerical illustration, let us suppose that the pipe is of such size, in connection with other circumstances, that the tension p_n' at A , a distance $x =$ six miles from m' , is two atmospheres, the tension in the receiving reservoir being one atmosphere; that is, that the loss of tension between A and m' is one atmosphere. If we express tensions in atmospheres and distances in miles, we have for the value of the constant in eq. (6), for this case,

$$\text{Const.} = (4 - 1) \div 6 = \frac{3}{6}; \text{ (for assumed units.)} \dots (7)$$

Now let $p_n' =$ the tension at B , a point 18 miles from m' , and we have, from eqs. (6) and (7), the tension at $B = 3.16$ atmospheres. Proceeding in this manner, the following set of values is obtained :

Point.	Total distance from m' .	Distance between consecutive points.	Tension at point.	Loss of tension in each interval.
<i>F</i>	126 miles.	36 miles.	8.00 atm.	1.22 atm.
<i>E</i>	90 "	50 "	6.78 "	1.22 "
<i>D</i>	60 "	24 "	5.56 "	1.21 "
<i>C</i>	36 "	18 "	4.35 "	1.19 "
<i>B</i>	18 "	12 "	3.16 "	1.16 "
<i>A</i>	6 "	6 "	2.00 "	1.00 "
<i>m'</i>	0 "	1.00 "

If the distances and tensions in the second and fourth columns be plotted as abscissæ and ordinates of a curve, the latter is a parabola with its axis following the axis of the pipe; its vertex is not at m' , however.

561. Long Pipe of Variable Diameter.—Another way of stating the fact mentioned in the last paragraph is as follows: At the up-stream end of the pipe of *uniform diameter* the gas is of much greater density than at the other extremity (the heaviness is directly as the tension, the temperature being assumed the same throughout the pipe), and the velocity of its motion is smaller than at the discharging end (in the same ratio). It is true that the frictional resistance per unit of length of pipe varies directly as the heaviness [eq. (1), § 510], but also true that it varies as the *square* of the velocity; so that, for instance, if the pressure at a point *A* is double that at *B* in the pipe of constant diameter, it implies that the heaviness and velocity at *A* are double and half, respectively, those at *B*, and thus the gas at *A* is subjected to only half the frictional resisting force per foot of length as compared with that at *B*. Hence the relatively small diminution, per unit of length, in the tension at the up-stream end in the example of the last paragraph.

In the pipe of uniform diameter, as we have seen, the greater part of the length is subjected to a comparatively high tension, and is thus under a greater liability to loss by leakage than if the decrease of tension were more uniform. The total "*hoop-tension*" (§ 426) in a unit length of pipe, also, is proportional to the gas tension, and thinner walls might be employed for the down-stream portions of the pipe if the gas

tension in those portions could be made smaller than as shown in the preceding example.

To secure a more rapid fall of pressure at the up-stream end of the pipe, and at the same time provide for the same delivery of gas as with a pipe of uniform diameter throughout, a pipe of *variable* diameter may be employed, that diameter being considerably smaller at the inlet than that of the uniform pipe but progressively enlarging down-stream. This will require the diameters of portions near the discharging end to be larger than in the uniform pipe, and if the same thickness of metal were necessary throughout, there would be no saving of metal, but rather the reverse, as will be seen; but the diminished thickness made practicable in those parts from a less total hoop tension than in the corresponding parts of the uniform pipe more than compensates for the extra metal due to increased circumference, aside from the diminished liability to leakage, which is of equal importance.

A simple numerical example will illustrate the foregoing. The pipe being circular, we may replace F by $\frac{1}{4}\pi d^2$ in equation (4), and finally derive, G being given,

$$d = Const. \times \left[\frac{l}{p_n^2 - p_m^2} \right]^{\frac{1}{2}} = C. \left[\frac{l}{p_n^2 - p_m^2} \right]^{\frac{1}{2}} \quad (8)$$

Let A be the head reservoir, and m' the receiving reservoir, and B a point half-way between. At A the tension is 10 atmospheres; at m' , 2 atmospheres. For transmitting a given weight of gas per unit-time, through a pipe of constant diameter throughout, that diameter must be (tensions in atmospheres; $2l$, being the length), by eq. (8),

$$d = Cl_0^{\frac{1}{2}} \left[\frac{2}{100 - 4} \right]^{\frac{1}{2}} = Cl_0^{\frac{1}{2}} (.0208)^{\frac{1}{2}} = 0.46 Cl_0^{\frac{1}{2}} \quad (8),$$

If we substitute for the pipe mentioned, another having a constant diameter d_1 from A to B , where we wish the tension to be 5 atmospheres, and a different constant diameter d_2 from B to m' , we derive similarly

$$d_1 = Cl_0^{\frac{1}{2}} \left[\frac{1}{100 - 25} \right]^{\frac{1}{2}} = 0.42 Cl_0^{\frac{1}{2}}$$

and

$$d_1 = C\bar{u} \left[\frac{1}{25 - 4} \right]^{\frac{1}{2}} = 0.54 C\bar{u}$$

It is now to be noted that the sum of d_1 and d_2 is slightly greater than the double of d ; so that if the same thickness of metal were used in both designs the compound pipe would require a little more material than the uniform pipe; but, from the reasoning given at the beginning of this paragraph, that thickness may be made considerably less in the down-stream part of the compound pipe, and thus economy secured.

[In case of a cessation of the flow, the gas tension in the whole pipe might rise to an equality with that of the head-reservoir were it not for the insertion, at intervals, of automatic regulators, each of which prevents the decrease of tension on its down-stream side below a fixed value. To provide for changes of length due to rise and fall of temperature, the pipe is laid with slight undulations.]

It is a noteworthy theoretical deduction that a given pipe of variable diameter connecting two reservoirs of gas at specified pressures will deliver the same weight of gas as before, if *turned end for end*. This follows from equation (3)', § 559. With d variable, (3)' becomes (with $F = \frac{1}{4}\pi d^2$)

$$\int_{n'}^{m'} (-pdp) = G^2 C'' \int_{n'}^{m'} \frac{ds}{d^5}; \quad \text{i.e.,} \quad G^2 = \frac{p_n^2 - p_m^2}{2C'' \int_{n'}^{m'} \frac{ds}{d^5}} \quad (9)$$

(C'' is a constant.)

But $\int_{n'}^{m'} \frac{ds}{d^5}$ is evidently the same in value if the pipe be turned end for end. In commenting on this circumstance, we should remember (see § 559) that the loss of pressure along the pipe is ascribed *entirely to frictional resistance*, and in no degree to changes of velocity (inertia).

On p. 73 of the *Engineering News* of July 1887 are given the following dimensions of a compound pipe in actual use, and delivering natural gas. The pressure in the head-reservoir is 319 lbs. per sq. in.; that in the receiving reservoir, 65. For 2.84 miles from the head-reservoir the diameter of the pipe is

8 in.; throughout the next 2.75 miles, 10 in.; while in the remaining 3.84 miles the diameter is 12 in. At the two points of junction the pressures are stated to be 185 and 132 lbs. per sq. in., respectively, during the flow of gas under the conditions mentioned.

561a. Values of the Coefficient of Fluid Friction for Natural Gas.—In the Ohio Report on Economic Geology for 1888 may be found an article by Prof. S. W. Robinson of the University of that State describing a series of interesting experiments made by him on the flow of natural gas from orifices and through pipes. By the insertion of Pitot tubes approximate measurements were made of the velocity of the stream of gas in a pipe. The following are some of the results of these experiments, $p_1 - p_2$ representing the loss of pressure (in lbs. per sq. inch) per mile of pipe-length, and f the coefficient of fluid friction, in experiments with a six-inch pipe :

$p_1 - p_2$	1.00	1.50	2.25	2.50	5.75	6.25
f	0.0025	0.0037	0.0052	0.0059	0.0070	0.0080

In the flow under observation Prof. Robinson concluded that f could be taken as approximately proportional to the fourth root of the cube of the velocity of flow; though calling attention to the fact that very reliable results could hardly be expected under the circumstances.

561b. [Addendum to § 559.] Isothermal Flow in a level pipe, with consideration of Inertia.—In eq. (1) of p. 697 neglect dz , put $w \div F = 4 \div d$, and divide through by v^2 . In the second term put $G^2 \div F^2 \gamma^2$ for v^2 and then $p(\gamma_m \div p_m)$ for γ . We now find the variables separated, and on integration for steady flow obtain (after putting $v_n \div v_m = F\gamma_m \div F\gamma_n = p_m \div p_n$),

$$\log_e \left(\frac{p_n}{p_m} \right) - \frac{g(p_n^2 - p_m^2)}{2} \cdot \frac{F^2}{G^2} \cdot \frac{\gamma_m}{p_m} = - \frac{2fl}{d}$$

[Notation as in § 557 with $G = Fv\gamma$.]

CHAPTER IX.

IMPULSE AND RESISTANCE OF FLUIDS.

562. The so-called "Reaction" of a Jet of Water flowing from a Vessel.—In Fig. 624, if a frictionless but water-tight plug B

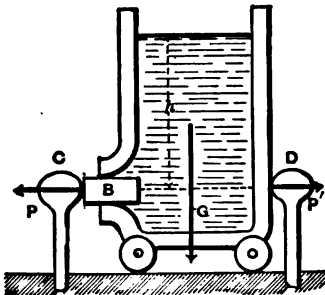

FIG. 624.

be inserted in an orifice in the vertical side of a vessel mounted on wheels, the resultant action of the water on the rigid vessel (as a whole) consists of its weight G , and a force $P' = Fh\gamma$ (in which F = the area of orifice) which is the excess of the horizontal hydrostatic pressures on the vessel wall toward the right (\parallel to paper) over those toward the left, since the

pressure $P, = Fh\gamma$, exerted on the plug is felt by the post C , and not by the vessel. Hence the post D receives a pressure

$$P' = Fh\gamma. \quad \dots \dots \dots (1)$$

Let the plug B be removed. A steady flow is then set up through the orifice, and now the pressure against the post D is $2Fh\gamma$ (as will be proved in the next paragraph); for not only is the pressure $Fh\gamma$ lacking on the left, because of the orifice, but the sum of all the horizontal components (\parallel to paper) of the pressures of the liquid filaments against the vessel wall around the orifice is less than its value before the flow began, by an amount $Fh\gamma$. A resistance $R = 2Fh\gamma$ being provided, and the post removed, a slow uniform motion may be maintained toward the right, the working force being $2Fh\gamma = P''$

(see Fig. 625; R is not shown). If an insufficient resistance be furnished before removing the post D , the vessel will begin to move toward the right with an *acceleration*, which will disturb the surface of the water and change the value of the horizontal force. This force

$$P'' = 2Fh\gamma \dots (2)$$

is called the “*reaction*” of the water-jet; γ is the heaviness of the liquid (§ 7).

Of course, as the flow goes on, the water level sinks and the “*reaction*” diminishes accordingly. Looked upon as a motor, the vessel may be considered to be a piston-less and valve-less water-pressure engine, carrying its own reservoir with it.

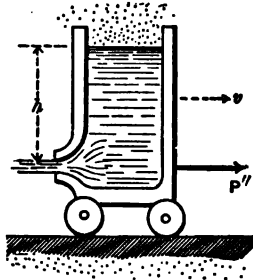

FIG. 625.

In Case II of § 500 we have already had a treatment of the “*Reaction-wheel*” or “*Barker’s mill*,” which is a practical machine operating on this principle, and will be again considered in “*Notes on Hydraulic Motors*.”

563. “*Reaction*” of a Liquid Jet on the Vessel from which it Issues.—Instead of showing that the pressures on the vessel close to the orifice are less than they were when there was no flow by an amount $Fh\gamma$ (a rather lengthy demonstration), another method will be given, of greater simplicity but somewhat fanciful.

If a man standing on the rear platform of a car is to take up in succession, from a basket on the car, a number of balls of equal mass = M , and project each one in turn horizontally backward with an acceleration = p , he can accomplish this only by exerting against each ball a pressure = Mp , and in the opposite direction against the car an equal pressure = Mp . If this action is kept up continuously the car is subjected to a constant and continuous forward force of $P'' = Mp$.

Similarly, the backward projection of the jet of water in the case of the vessel at rest must occasion a forward force against the vessel of a value dependent on the fact that in each small interval of time Δt a small mass ΔM of liquid has its velocity changed from zero to a backward velocity of $v = \sqrt{2gh}$; that

is, has been projected with a mean acceleration of $p = \frac{v-0}{\Delta t}$, so that the forward force against the vessel is

$$P'' = \text{mass} \times \text{acc.} = \frac{\Delta M \cdot v}{\Delta t} \dots (3)$$

If Q = the volume of water discharged per unit time, then $\Delta M = \frac{Q\gamma}{g} \Delta t$, and since also $Q = Fv = F\sqrt{2gh}$, eq. (3) becomes "Reaction" of jet = $P'' = 2Fh\gamma \dots (4)$

(A similar proof, resulting in the same value for P'' , is easily made if the vessel has a uniform motion with water surface horizontal.)

If the orifice is in "thin plate," we understand by F the area of the contracted section. Practically, we have $v = \phi\sqrt{2gh}$ (§ 495), and hence (3) reduces to

$$P'' = 2\phi^2 Fh\gamma \dots (5)$$

Weisbach mentions the experiments of Mr. Peter Ewart of Manchester, England, as giving the result $P'' = 1.73Fh\gamma$ with a well-rounded orifice as in Fig. 625. He also found $\phi = .94$ for the same orifice, so that by eq. (4) we should have

$$P'' = 2(.94)^2 Fh\gamma = 1.77Fh\gamma.$$

With an orifice in thin plate Mr. Ewart found $P'' = 1.14Fh\gamma$. As for a result from eq. (4), we must put, for F , the area of the contracted section $.64F$ (§ 495), which, with $\phi = .96$, gives

$$P'' = 2(.96)^2 \cdot 64Fh\gamma = 1.18Fh\gamma \dots (6)$$

Evidently both results agree well with experiment.

Experiments made by Prof. J. B. Webb at the Stevens Institute (see Journal of the Franklin Inst., Jan. '88, p. 35) also confirm the foregoing results. In these experiments the vessel was suspended on springs and the jet directly downward, so that the "reaction" consisted of a diminution of the tension of the springs during the flow.

564. Impulse of a Jet of Water on a Fixed Curved Vane (with Borders).—The jet passes tangentially upon the vane. Fig.

626. *B* is the stationary nozzle from which a jet of water of cross-section *F* (area) and velocity = *c* impinges tangentially upon the vane, which has plane borders, parallel to paper, to prevent the lateral escape of the jet. The curve of the vane is not circular necessarily. The vane being smooth, the velocity of the water in its curved path remains = *c* at all points along the curve. Conceive the curve divided into a great number of small lengths each = *ds*, and subtending some angle = *dφ* from its own centre of curvature, its radius of curvature being = *r* (different for different *ds*'s), which makes some angle = *φ* with the axis *Y* (⊥ to original straight jet *BA*). At any instant of time there is an arc of water *AD* in contact with the vane, exerting pressure upon it. The pressure *dP* of any *ds* of the vane against the small mass of water *Fds*. $\gamma \div g$ then in contact with it is the "deviating" or "centripetal" force accountable for its motion in a curve of radius = *r*, and hence must have a value

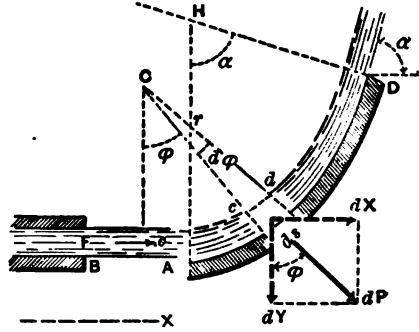

FIG. 626.

each = *ds*, and subtending some angle = *dφ* from its own centre of curvature, its radius of curvature being = *r* (different for different *ds*'s), which makes some angle = *φ* with the axis *Y* (⊥ to original straight jet *BA*). At any instant of time there is an arc of water *AD* in contact with the vane, exerting pressure upon it. The pressure *dP* of any *ds* of the vane against the small mass of water *Fds*. $\gamma \div g$ then in contact with it is the "deviating" or "centripetal" force accountable for its motion in a curve of radius = *r*, and hence must have a value

$$dP = \frac{F\gamma ds}{g} \cdot \frac{c^2}{r} \dots (\S 76) \dots (1)$$

The opposite and equal of this force is the *dP* shown in Fig. 614, and is the impulse or pressure of this small mass against the vane. Its *X*-component is *dX* = *dP* sin *φ*. By making *φ* vary from 0 to *α*, and adding up the corresponding values of *dX*, we obtain the sum of the *X*-components of the small pressures exerted simultaneously against the vane by the arc of water then in contact with it; i.e., noting that *ds* = *r**dφ*,

$$\begin{aligned} \therefore \int_{\phi=0}^{\phi=\alpha} dX &= \int_0^\alpha dP \cdot \sin \phi = \frac{F\gamma c^2}{g} \int_0^\alpha \frac{ds \cdot \sin \phi}{r} \\ &= \frac{F\gamma c^2}{g} \int_0^\alpha [\sin \phi] d\phi = \frac{F\gamma c^2}{g} \left[-\cos \phi \right]_0^\alpha \end{aligned}$$

hence the X -impulse } = $\frac{F\gamma c}{g}[1 - \cos \alpha] = \frac{Q\gamma c}{g}[1 - \cos \alpha]$, (2)
 against fixed vane

in which $Q = Fc =$ volume of water which passes through the nozzle (and also = that passing over the vane, in this case) per unit of time, and $\alpha =$ angle between the direction of the stream leaving the vane (i.e., at D) and its original direction (BA of the jet); i.e., $\alpha =$ total angle of deviation. Similarly, the sum of the Y -components of the dP 's of Fig. 626 may be shown to be

$$Y\text{-impulse on fixed vane} = \int_0^\alpha dP \cdot \cos \phi = \frac{Q\gamma c}{g} \sin \alpha \dots (2)'$$

Hence the resultant impulse on the vane is a force

$$P'' = \sqrt{X^2 + Y^2} = \frac{Q\gamma c}{g} \sqrt{2(1 - \cos \alpha)}, \dots (3)$$

and makes such an angle α' , Fig. 627, with the direction BA , that

$$\tan \alpha' = \frac{Y}{X} = \frac{\sin \alpha}{1 - \cos \alpha} \dots \dots \dots (4)$$

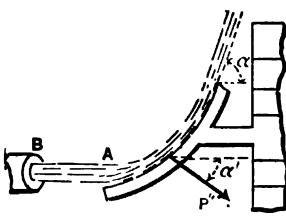

FIG. 627.

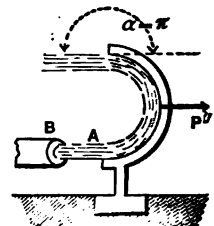

FIG. 628.

For example, if $\alpha = 90^\circ$, then $\alpha' = 45^\circ$; while if $\alpha = 180^\circ$, Fig. 628, we have $\alpha' = 0^\circ$; i.e., P'' is parallel to the jet BA , and its value is

$$P'' = 2Q\gamma \frac{c}{g}.$$

565. Impulse of a Jet on a Fixed Solid of Revolution whose Axis is Parallel to the Jet.—If the curved vane, with borders, of the preceding paragraph be replaced by a solid of revolution, Fig. 629, with its axis in line of the jet, the resultant pressure of the jet upon it will simply be the sum of the X -components (i.e., = to BA) of the pressures on all elements of the surface at a given instant; i.e.,

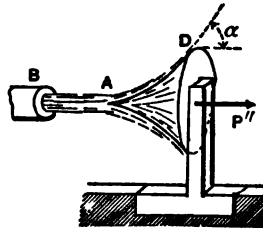

FIG. 629.

$$X = P'' = Q\gamma \frac{c}{g} (1 - \cos \alpha); \dots (5)$$

while the components γ to X , all directed toward the axis of the solid, neutralize each other. For a *fixed plate*, then, Fig. 630, at right angles to the jet, we have for the force, or “impulse” (with $\alpha = 90^\circ$),

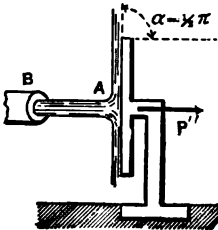

FIG. 630.

$$P'' = \frac{Q\gamma}{g} c = \frac{Fc^2}{g} \gamma = 2F \frac{c^2}{2g} \gamma. \dots (6)$$

The experiments of Bidone, made in 1838, confirm the truth of eq. (6) quite closely, as do also those of two students of the University of Pennsylvania at Philadelphia (see Jour. of the Frank. Inst. for Oct. '87, p. 258).

Eq. (6) is applicable to the theory of Pitot's Tube (see § 539), Fig. 631, if we consider the edge of the tube plane and quite wide. The water in the tube is at rest, and its section at A (of area = F) may be treated as a flat vertical plate receiving not only the hydrostatic pressure Fxy , due to the depth x below the surface, but a continuous impulse $P'' = Fc^2\gamma \div g$ [see eq. (6)]

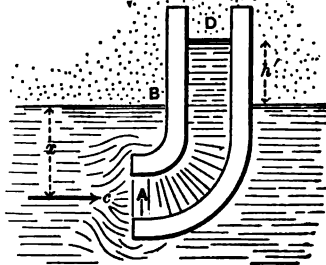

FIG. 631.

For the equilibrium of the end *A*, of the stationary column *AD*, we must have, therefore,

$$Fxy + \frac{Fc^2\gamma}{g} = Fxy + Fh'\gamma; \text{ i.e., } h' = (2.0) \frac{c^2}{2g}. \quad (7)$$

The relation in equation (7) corresponds reasonably well with the results of Weisbach's experiments with the instrument mentioned in § 539. Pitot himself, on trial of an instrument in which the edges of the tube at *A* were made flaring or conically divergent, like a funnel, found

$$h' = (1.5) \frac{c^2}{2g}; \dots \dots \dots (7')$$

while Darcy, desirous that the end of the tube should occasion as little disturbance as possible in the surrounding stream, made the extremity small and conically convergent.* The latter obtained the relation

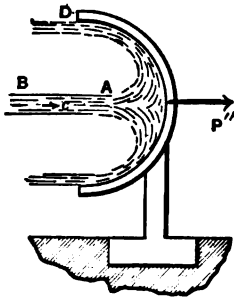

FIG. 632.

$$h' = \text{almost exactly } (1.0) \frac{c^2}{2g}. \quad (7'')$$

(See § 539.)

If the solid of revolution is made cup-shaped, as in Fig. 632, we have (as in Fig. 628) $\alpha = 180^\circ$, and therefore, from eq. (5),

$$P'' = 2Q\gamma \frac{c}{g} = \frac{2Fc^2\gamma}{g} = 4F \left(\frac{c^2}{2g} \right) \gamma. \dots \dots (8)$$

EXAMPLE.—Fig. 632. If $c = 30$ ft. per sec. and the jet (cylindrical) has a diameter of 1 inch, the liquid being water, so that $\gamma = 62.5$ lbs. per cub. ft., we have [ft., lb., sec.]

$$\text{the impulse (force)} = P'' = \frac{2 \frac{\pi}{4} \left(\frac{1}{12} \right)^2 900 \times 62.5}{32.2} = 19.05 \text{ lbs.}$$

Experiment would probably show a smaller result.

* See p. 833 for Mr. Freeman's Experiments.

566. Impulse of a Liquid Jet upon a Moving Vane having Lateral Borders and Moving in the Direction of the Jet.—Fig. 633. The vane has a motion of translation (§ 108) in the same direction as the jet. Call this the axis X . It is moving with a velocity v away from the jet (or, if toward the jet, v is negative). We consider v constant, its acceleration being prevented by a proper resistance (such as a weight = G) to balance the X -components of the arc-pressures. Before coming in contact with the vane, which it does tangentially (to avoid sudden deviation), the absolute velocity (§ 83) of the water in the jet = c , while its velocity

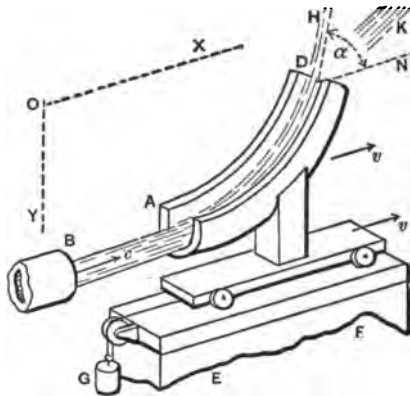

FIG. 633.

relatively to the vane at A is $= c - v$; and it will now be proved that the relative velocity along the vane is constant. See Fig. 634. Let v = the velocity of the vane (of each point of it, since its motion is one of translation), and u = the velocity of a water particle (or small mass of water of length = ds) relatively to the point of the vane which it is passing. Then w , the absolute velocity of the small mass, is the diagonal formed on u and v . Neglecting friction, the only actual force acting on the mass is P , the pressure of the vane against it, and this is normal to the curve. Now an imaginary system of forces, equivalent to this actual system of one force P , i.e., capable of producing the same motion in the mass, may be conceived of, consisting of the individual forces which would produce, separately, the separate motions of which the actual motion of this small mass M is compounded. These component motions are as follows:

1. A horizontal uniform motion of constant velocity = v ; and
2. A motion in the arc of a circle of radius = r and with a

velocity = u , which we shall consider variable until proved otherwise.

Motion 1 is of such a nature as to call for *no force* (by Newton's first law of motion), while motion 2 could be maintained by a system of two forces, one normal, $P_n = \frac{Mu^2}{r}$, and the other tangential, $P_t = M \frac{du}{dt}$ [see eq. (5), p. 76]. This imaginary system of forces is shown at (II.), Fig. 634, and is equiv-

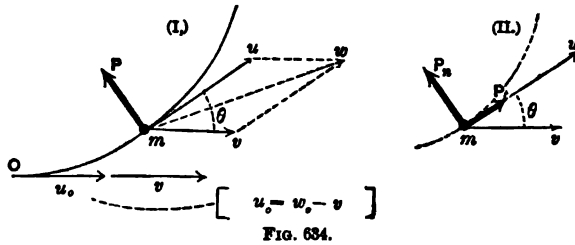

alent to the actual system at (I.). Therefore Σ (tang. comps.) in (I.) should be equal to Σ (tang. comps.) in (II.); whence we have

$$P_t = 0; \text{ i.e., } M \frac{du}{dt} = 0; \text{ or } \frac{du}{dt} = 0; \dots (1)$$

i.e., u is constant along the vane and is equal to $c - v$ at every point. (The weight of the mass has been neglected since the height of the vane is small.) In Fig. 634 the symbol w , has been used instead of c , and the point 0 corresponds to A in Fig. 633.

[N.B. If the motion of the vane were *rotary*, about an axis \perp to AB (or to c), this relative velocity would be different at different points. See Notes on Hydraulic Motors. If the radius of motion of the point A , however, is quite large compared with the projection of AD upon this radius, the relative velocity is approximately $= c - v$ at all parts of the vane, and will be taken $= c - v$ in treating the "Hurdy gurdy" in § 567.]

By putting Σ (normal comps.) of (I.) = Σ (normal comps.) in (II.) we have

$$P = P_n; \text{ i.e., } P = M \frac{u^2}{r} = \frac{M(c-v)^2}{r}; \dots (2)$$

so that to find the sum of the X -components of the pressures exerted against the vane simultaneously by all the small masses of water in contact with it at any instant, the analysis differs from that in § 564 only in replacing the c of that article by the $(c-v)$ of this. Therefore

$$\Sigma(X\text{-pressures}) = P_a = \frac{F\gamma}{g} (c-v)^2 [1 - \cos \alpha], \dots (3)$$

(where α is the angle of total deviation, relatively to vane, of the stream leaving the vane, from its original direction), and is seen to be proportional to the *square* of the relative velocity. F is the sectional area of jet, and γ the heaviness (§ 7) of the liquid. The Y -component (or P_y) of the resultant impulse is counteracted by the support EF , Fig. 633. Hence, *for a uniform motion to be maintained*, with a given velocity = v , the weight G must be made = P_a of eq. (3). (We here neglect friction and suppose the jet to preserve a practically horizontal direction for an indefinite distance before meeting the vane. If this uniform motion is to be *toward* the jet, v will be negative in eq. (3), making P_a (and $\therefore G$) larger than for a positive v of same numerical value.

As to the *doing of work* [§§ 128, etc.], or exchange of energy, between the two bodies, jet and vane, during a uniform motion *away* from the jet, P_a exerts a *power* of

$$L = P_a v = \frac{F\gamma}{g} (c-v)^2 v [1 - \cos \alpha], \dots (4)$$

in which L denotes the number of units of work done per unit of time by P_a ; i.e., the *power* (§ 130) exerted by P_a .

If v is negative, call it $-v'$, and we have the

$$\left. \begin{array}{l} \text{Power expended} \\ \text{by vane upon jet} \end{array} \right\} = P_a v' = \frac{F\gamma}{g} (c+v')^2 v' [1 - \cos \alpha]. \dots (5)$$

Of course, practically, we are more concerned with eq. (4) than with (5). The power L in (4) is a maximum for $v = \frac{1}{2}c$; but in practice, since a single moving vane or float cannot utilize the water of the jet as fast as it flows from the nozzle, let us conceive of a succession of vanes coming into position consecutively in front of the jet, all having the same velocity v ; then the portion of jet intercepted between two vanes is at liberty to finish its work on the front vane, while additional work is being done on the hinder one; i.e., the water will be utilized as fast as it issues from the nozzle.

With such a *series of vanes*, then, we may put $Q' = Fc$, the volume of flow per unit of time from the nozzle, in place of $F(c - v)$ = the volume of flow per unit of time over the vane, in eq. (4); whence

$$\left. \begin{array}{l} \text{Power exerted on} \\ \text{series of vanes} \end{array} \right\} = L' = \frac{Q'\gamma}{g} [1 - \cos \alpha](c - v)v. \quad (6)$$

Making v variable, and putting $dL' \div dv = 0$, whence $c - 2v = 0$, we find that for $v = \frac{1}{2}c$, L' , the power, is a maximum. Assuming different values for α , we find that for $\alpha = 180^\circ$, i.e., by the use of a semicircular vane, or of a hemispherical cup, Fig. 635, with a point in middle, $1 - \cos \alpha$ is a max., = 2; whence, with $v = \frac{1}{2}c$, we have, as the *maximum power*,

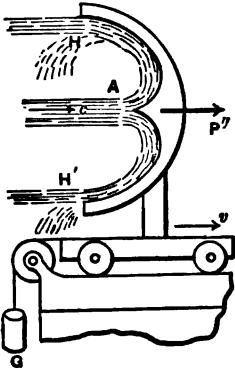

FIG. 635.

$$L'_{\max.} = \frac{Q'\gamma}{g} \cdot \frac{c^2}{2} = \frac{M'c^2}{2}; \left\{ \begin{array}{l} \alpha = 180^\circ, \\ v = \frac{1}{2}c; \end{array} \right\} \dots (7)$$

in which M' denotes the mass of the flow per unit of time from the stationary nozzle. Now $\frac{M'c^2}{2}$ is the *entire kinetic energy* furnished per unit of time by the jet; hence the motor of Fig. 635 (*series of cups*) has a theoretical efficiency of

unity, utilizing all the kinetic energy of the water. If this is true, the absolute velocity of the particles of liquid where they leave the cup, or vane, should be *zero*, which is seen to be true,

as follows: At H , or H' , the velocity of the particles relatively to the vane is $= c - v =$ what it was at A , and hence is $= c - \frac{c}{2} = \frac{c}{2}$; hence at H the absolute velocity is $w =$ (rel. veloc. $\frac{c}{2}$ toward left) $-$ (veloc. $\frac{c}{2}$ of vane toward right) $= 0$; Q.E.D. For $v >$ or $< \frac{1}{2}c$ this efficiency will not be attained.

567. The California "Hurdy-gurdy;" or Pelton Wheel.—The efficiency of unity in the series of cups just mentioned is in practice reduced to 80 or 85 per cent from friction and lateral escape of water. The Pelton wheel or California "Hurdy-gurdy," shown (in principle only) in Fig. 636, is designed to utilize the mechanical relation just presented, and yields results confirming the above theory, viz., that with the linear velocity of the

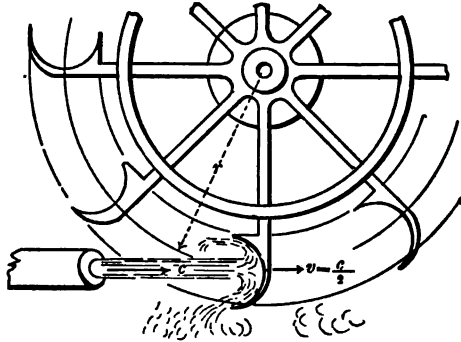

FIG. 636.

cup-centres regulated to equal $\frac{c}{2}$, and with $\alpha = 180^\circ$, the efficiency approaches unity or 100 per cent. Each cup has a projecting sharp edge or rib along the middle, to split the jet; see Fig. 635.

This wheel was invented to utilize small jets of very great velocities (c) in regions just deserted by "hydraulic mining" operators. Although c is great, still, by giving a large value to r , the radius of the wheel, the making of $v = \frac{c}{2}$ does not necessitate an inconveniently great speed of rotation (i.e., revolutions per unit of time). The plane of the wheel may be in any convenient position.

In the London *Engineer* of May '84, p. 397, is given an account of a test* made of a "Hurdy-gurdy," in which the motor

* See p. 884 for further details of this test and a perspective view of wheel.

showed an efficiency of 87 per cent. The diameter of the wheel was only 6 ft., that of the jet 1.89 in., and the head of the supply reservoir 386 ft., the water being transmitted through a pipe of 22 inches diameter and 6900 ft. in length. 107 H. P. was developed by the wheel.

EXAMPLE.—If the jet in Fig. 636 has a velocity $c = 60$ ft. per second, and is delivered through a 2-inch nozzle, the total power due to the kinetic energy of the water is (ft., lb., sec.)

$$\frac{Q' \gamma}{g} \cdot \frac{c^3}{2} = \frac{1}{32.2} \cdot \frac{\pi \left(\frac{2}{12}\right)^3}{4} \times 60 \times 62.5 \times \frac{1}{2} \times 3600 = 4566.9 \left\{ \begin{array}{l} \text{ft. lbs.} \\ \text{p. sec.} \end{array} \right.$$

and if, by making the velocity of the cups $= \frac{c}{2} = 30$ ft. per sec., 85 per cent of this power can be utilized, the power of the wheel at this most advantageous velocity is

$$L = .85 \times 4566.9 = 3881 \text{ ft. lbs. per sec.} = 7.05 \text{ horse-power}$$

[since $3881 \div 550 = 7.05$] (§ 132). For a cup-velocity of 30 ft. per sec., if we make the radius, $r = 10$ feet, the angular velocity of the wheel will be $\omega = v \div r = 3.0$ radians per sec. (for radian see Example in § 428; for angular velocity, § 110), which nearly $= \pi$, thus implying nearly a half-revolution per sec.

568. Oblique Impact of a Jet on a Moving Plate having

no Border.—The plate has a motion of translation with a uniform veloc. $= v$ in a direction parallel to jet, whose velocity is $= c$. At O the filaments of liquid are deviated, so that in leaving the plate their particles are all found in the moving plane BB' of the plate

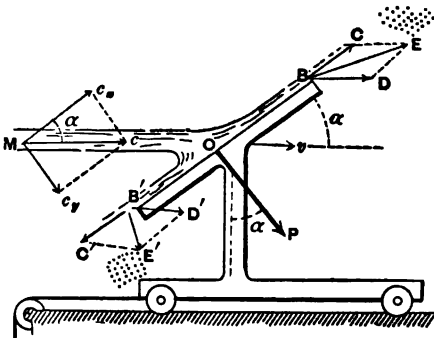

FIG. 687.

surface, but the respective absolute velocities of these particles

depend on the location of the point of the plate where they leave it, being found by forming a diagonal on the relative veloc. $c - v$ and the velocity v of the plate. For example, at B the absolute velocity of a liquid particle is

$$w = BE = \sqrt{v^2 + (c - v)^2 + 2v(c - v) \cos \alpha},$$

while at B' it is

$$w' = B'E' = \sqrt{v^2 + (c - v)^2 - 2v(c - v) \cos \alpha};$$

but evidently the component \perp to plate (the other component being parallel) of the absolute velocities of *all particles leaving* the plate, is the same and $= v \sin \alpha$. The skin-friction of the liquid on the plate being neglected, the resultant impulse of the jet against the plate must be *normal* to its surface, and its amount, P , is most readily found as follows:

Denoting by ΔM the mass of the liquid passing over the plate in a short time Δt , resolve the absolute velocities of all the liquid particles, before and after deviation, into components \perp to the plate (call this direction Y) and \parallel to the plate. Before meeting the plate the particles composing ΔM have a velocity in the direction of Y of $c_y = c \sin \alpha$; on leaving the plate a velocity in direction of Y of $v \sin \alpha$: they have therefore lost an amount of velocity in direction of $Y = (c - v) \sin \alpha$ in time Δt ; i.e., they have suffered an average retardation (or negative acceleration) in a Y -direction of

$$p_v = \left\{ \begin{array}{l} \text{neg. accelera-} \\ \text{tion } \parallel \text{ to } Y \end{array} \right\} = \frac{(c - v) \sin \alpha}{\Delta t} \dots \dots (1)$$

Hence the resistance in direction of Y (i.e., the equal and opposite of P in figure) must be

$$P_Y = \text{mass} \times Y\text{-accel.} = \frac{\Delta M}{\Delta t} (c - v) \sin \alpha; \dots (2)$$

and therefore, since $\frac{\Delta M}{\Delta t} = M = \frac{QY}{g} = \text{mass of liquid passing}$

over the plate per unit of time (not that issuing from nozzle), we have

$$\left. \begin{array}{l} \text{Impulse or pres-} \\ \text{sure on plate} \end{array} \right\} = P = \frac{Q\gamma}{g}(c-v)\sin\alpha = \frac{F\gamma}{g}(c-v)^2\sin\alpha, \quad (3)$$

in which F = sectional area of jet before meeting plate.

[N.B. Since eq. (3) can also be written $P = Mc\sin\alpha - Mv\sin\alpha$, and $Mc\sin\alpha$ may be called the Y -momentum before contact, while $Mv\sin\alpha$ is the Y -momentum after contact (of the mass passing over plate per unit of time), this method may be said to be founded on the *principle of momentum* which is nothing more than the relation that the accelerating force in any direction = mass \times acceleration in that direction; e.g., $P_x = Mp_x$; $P_y = Mp_y$; see § 74.]

If we resolve P , Fig. 637, into two components, one, P' , \parallel to the direction of motion (v and c), and the other, P'' , \perp to the same, we have

$$P' = P\sin\alpha = \frac{Q\gamma}{g}(c-v)\sin^2\alpha, \quad \dots \quad (4)$$

and

$$P'' = P\cos\alpha = \frac{Q\gamma}{g}(c-v)\sin\alpha\cos\alpha. \quad \dots \quad (5)$$

($Q = F(c-v)$ = volume passing over the plate per unit of time.) The force P'' does no work, while the former, P' , does an amount of work $P'v$ per unit of time; i.e., exerts a *power* (one plate)

$$= L = P'v = \frac{Q\gamma}{g}(c-v)v\sin^2\alpha. \quad \dots \quad (6)$$

If, instead of a single plate, a *series of plates*, forming a regular succession, is employed, then, as in a previous paragraph, we may replace $Q = F(c-v)$, by $Q' = Fc$, obtaining as the

$$\left. \begin{array}{l} \text{Power exerted by jet} \\ \text{on series of plates} \end{array} \right\} = L' = \frac{F\gamma}{g}(c-v)v\sin^2\alpha. \quad (7)$$

For $v = \frac{c}{2}$ and $\alpha = 90^\circ$ we have

$$L'_{\max} = \frac{1}{2} \frac{Fcy}{g} \frac{c^2}{2} = \frac{1}{2} \frac{M'c^2}{2} \dots \dots \dots (8)$$

= only half the kinetic energy (per time-unit) of the jet.

589. Rigid Plates Moving in a Fluid, Totally Submerged. Fluid Moving against a Fixed Plate. Impulse and Resistance.—

If a thin flat rigid plate have a motion of uniform translation with velocity = v through a fluid which completely surrounds it, Fig. 638, a resistance is encountered (which must be overcome by an equal and opposite force, not shown in figure, to preserve the uniform motion) consisting of a normal component N , \perp to plate, and a (small) tangential component, or skin-friction, T , \parallel to plate.

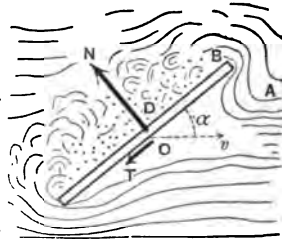

FIG. 638.

Unless the angle α , between the surface of plate and the direction of motion $O \dots v$, is very small, i.e. unless the plate is moving nearly edgewise through the fluid, N is usually much greater than T . The skin-resistance between a solid and a fluid has already been spoken of in § 510.

When the plate and fluid are at rest the pressures on both sides are normal and balance each other, being ordinary static fluid pressures. When motion is in progress, however, the normal pressures on the front surface are increased by the components, normal to plate, of the centrifugal forces of the curved filaments (such as AB) or "stream-lines," while on the back surface, D , the fluid does not close in fast enough to produce a pressure equal to that (even) of rest. In fact, if the motion is sufficiently rapid, and the fluid is inelastic (a liquid), a vacuum may be maintained behind the plate, in which case there is evidently no pressure on that side of the plate.

Whatever pressure exists on the back acts, of course, to diminish the resultant resistance. The water on turning the sharp corners of the plate is broken up into eddies forming a

“wake” behind. From the accompaniment of these eddies, the resistance in this case (at least the component N normal to plate) is said to be due to “eddy-making;” though logically we should say, rather, that the body does not derive the assistance (or negative resistance) from behind which it would obtain if eddies were not formed; i.e., if the fluid could close in behind in smooth curved stream-lines symmetrical with those in front.

The *heat* corresponding to the change of temperature produced in the portion of fluid acted on, by the skin-friction and by the mutual friction of the particles in the eddies, is the equivalent of the work done (or energy spent) by the motive force in maintaining the uniform motion (§ 149). (Joule’s experiments to determine the Mechanical Equivalent of Heat were made with paddles moving in water.)

If the fluid is *sea-water*, the results of Col. Beaufoy’s experiments are applicable, viz.:

The resistance, per square foot of area, sustained by a submerged plate moving normally to itself [i.e., $\alpha = 90^\circ$] in sea-water with a velocity of $v = 10$ ft. per second is 112 lbs. He also asserts that for other velocities the resistance varies as the square of the velocity. This latter fact we would be led to suspect from the results obtained in § 568 for the impulse of jets; also in § 565 [see eq. (6)]. Also, that when the plate moved obliquely to its normal (as in Fig. 638) the resistance was nearly equal to (the resistance, at same velocity, when $\alpha = 90^\circ$) \times (the sine of the angle α); also, that the depth of submersion had no influence on the resistance.

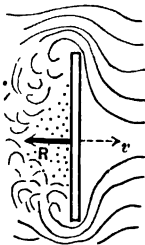

FIG. 639.

Confining our attention to a plate *moving normally to itself*, Fig. 639, let F = area of plate, γ = heaviness (§ 409) of the fluid, v = the uniform velocity of plate, and g = the acceleration of gravity (= 32.2 for the foot and second; = 9.81 for the metre and second). Then from the analogy of eq. (6), § 565, where velocity c of the jet against a stationary plate corresponds to the velocity v of the plate in the present case moving through a fluid at rest, we may write

$$\left. \begin{array}{l} \text{Resistance of fluid} \\ \text{to moving plate} \end{array} \right\} = R = \zeta F \gamma \frac{v^2}{2g} \dots \left\{ \begin{array}{l} v \text{ normal} \\ \text{to plate} \end{array} \right\} \dots (1)$$

And similarly for the *impulse of an indefinite stream of fluid against a fixed plate* (γ to velocity of stream), v being the velocity of the current,

$$\left. \begin{array}{l} \text{Impulse of current} \\ \text{upon fixed plate} \end{array} \right\} = P = \zeta' F \gamma \frac{v^2}{2g} \dots \left\{ \begin{array}{l} v \text{ normal} \\ \text{to plate} \end{array} \right\} \dots (2)$$

The $2g$ is introduced simply for convenience; since, having v given, we may easily find $v^2 \div 2g$ from a table of velocity-heads; and also (a ground of greater importance) since the coefficients ζ and ζ' which depend on experiment are evidently *abstract numbers* in the present form of these equations (for R and P are forces, and $F\gamma v^2 \div 2g$ is the weight (force) of an ideal prism of fluid; hence ζ and ζ' must be abstract numbers.)

From Col. Beaufoy's experiments (see above), we have for *sea-water* [ft., lb., sec.], putting $R = 112$ lbs., $F = 1$ sq. ft., $\gamma = 64$ lbs. per cub. ft., and $v = 10$ ft. per second,

$$\zeta = \frac{2 \times 32.2 \times 112}{1.0 \times 64 \times 10^2} = 1.13.$$

Hence in eq. (1) for sea-water, we may put $\zeta = 1.13$ (with $\gamma = 64$ lbs. per cub. ft.).

From the experiments of Dubuat and Thibault, Weisbach computes that for the plate of Fig. 639, moving through either water or air, $\zeta = 1.25$ for eq. (1), in which the γ for air must be computed from § 437; while for the impulse of water or air on fixed plates he obtains $\zeta' = 1.86$ for use in eq. (2). It is hardly reasonable to suppose that ζ and ζ' should not be identical in value, and Prof. Unwin thinks that the difference in the numbers just given must be due to errors of experiment. The latter value, $\zeta' = 1.86$, agrees well with equation (6) below. For great velocities ζ and ζ' are greater for air than for water, since air, being compressible, is of greater heaviness in front of the plate than would be computed for

the given temperature and barometric height for use in eqs. (1) and (2)

The experiments of Borda in 1763 led to the formula

$$P = [0.0031 + 0.00035c]Sv^2 \quad \quad (3)$$

for the total pressure upon a plate moving through the air in a direction γ to its own surface. P is the pressure in pounds, c the length of the contour of the plate in feet, and S its surface in square feet, while v is the velocity in miles per hour. Adopting the same form of formula, Hagen found, from experiments in 1873, the relation

$$P = [0.002894 + 0.00014c]Sv^2 \quad . . . \quad (4)$$

for the same case of fluid resistance.

Hagen's experiments were conducted with great care, but like Borda's were made with a "whirling machine," in which the plate was caused to revolve in a horizontal circle of only 7 or 8 feet radius at the end of a horizontal bar rotating about a vertical axis. Hagen's plates ranged from 4 to 40 sq. in. in area, and the velocities from 1 to 4 miles per hour.

The last result was quite closely confirmed by Mr. H. Allen Hazen at Washington in November 1886, the experiments being made with a whirling machine and plates of from 16 to 576 sq. in. area. (See the *American Journal of Science*, Oct. 1887, p. 245.)

In Thibault's experiments plates of areas 1.16 and 1.531 sq. ft. were exposed to direct wind-pressure, giving the formula

$$P = 0.00475Sv^2 \quad \quad (5)$$

Recent experiments in France (see *R. R. and Eng. Journal*, Feb. '87), where flat boards were hung from the side of a railway train run at different velocities, gave the formula

$$P = 0.00535Sv^2 \quad \quad (6)$$

The highest velocity was 44 miles per hour. The magnitude of the area did not seemingly affect the relation given. More

extended and elaborate experiments are needed in this field, those involving a motion of translation being considered the better, rather than with whirling machines, in which "centrifugal action" must have a disturbing influence.

The notation and units for eqs. (4), (5), and (6) are the same as those given for (3).

It may be of interest to note that if equation (3) of § 568 be considered applicable to this case of the pressure of an unlimited stream of fluid against a plate placed at right-angles to the current, with F put equal to the area of the plate, we obtain, after reduction to the units prescribed above for the preceding equations and putting $\alpha = 90^\circ$,

$$P = 0.0053Sv^2. \quad \dots \quad (7)$$

The value $\gamma = 0.0807$ lbs. per cub. ft. has been used in the substitution, corresponding to a temperature of freezing and a barometric height of 30 inches. At higher temperatures, of course, γ would be less, unless with very high barometer.

569a. Example.—Supposing each blade of the paddle-wheel of a steamer to have an area of 6 sq. ft., and that when in the lowest position its velocity [relatively to the water, not to the vessel] is 5 ft. per second; what resistance is it overcoming in salt water?

From eq. (1) of § 569, with $\zeta = 1.13$ and $\gamma = 64$ lbs. per cubic foot, we have (ft., lb., sec.)

$$R = \frac{1.13 \times 6 \times 64 \times 25}{2 \times 32.2} = 169.4 \text{ lbs.}$$

If on the average there may be considered to be three paddles always overcoming this resistance on each side of the boat, then the work lost (work of "slip") in overcoming these resistances per second (i.e., *power* lost) is

$$L_1 = [6 \times 169.4] \text{ lbs.} \times 5 \text{ ft. per sec.} = 5082 \text{ ft.-lbs. per sec.}$$

or 9.24 Horse Power (since $5082 \div 550 = 9.24$).

If, further, the velocity of the boat is *uniform* and = 20 ft. per sec., the resistance of the water to the progress of the boat at this speed being 6×169.4 , i.e. 1016.4 lbs., the power expended in actual propulsion is

$$L_2 = 1016.4 \times 20 = 20328 \text{ ft.-lbs. per sec.}$$

Hence the power expended in both ways (usefully in propulsion, uselessly in "slip") is

$$L_1 + L_2 = 25410 \text{ ft.-lbs. per sec.} = 46.2 \text{ H. P.}$$

Of this, 9.24 H. P., or about 20 per cent, is lost in "slip."

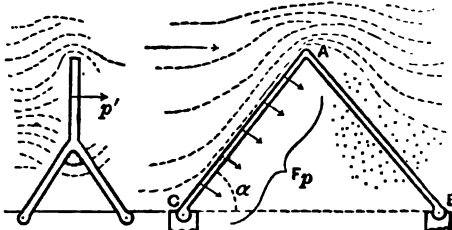

FIG. 640.

570. Wind-pressure on the surface of a roof inclined at an angle = α with the horizontal, i.e., with the direction of the wind, is usually estimated according to the empirical formula

(Hutton's)

$$p = p' [\sin \alpha]^{[1.84 \cos \alpha - 1]}, \dots \dots \dots (1)$$

in which p' = pressure of wind per unit area against a *vertical* surface (\perp to wind), and p = that against the inclined plane (*and normal to it*) at the same velocity. For a value of $p' = 40$ lbs. per square foot (as a maximum), we have the following values for p , computed from (1):

For $\alpha =$	5°	10°	15°	20°	25°	30°	35°	40°	45°	50°	55°	60°
$p =$ (lbs. sq. ft.)	5.2	9.6	14	18.9	22.5	26.5	30.1	33.4	36.1	38.1	39.6	40.

Duchemin's formula for the normal pressure per unit-area is

$$p = p' \cdot \frac{2 \sin^2 \alpha}{1 + \sin^2 \alpha}, \dots \dots \dots (2)$$

with the same notation as above. Some experimenters in London tested this latter formula by measuring the pressure on a metal plate supported in front of the blast-pipe of a blowing engine; the results were as follows:

$\alpha =$	15°	20°	60°	90°
p by experiment = (in lbs. per sq. ft.)	1.65	2.05	8.01	8.81
By Duchemin's formula $p =$	1.60	2.02	8.27	8.81

The scale of the Smithsonian Institution at Washington for the estimation and description of the velocity and pressure of the wind is as follows:

Grade.	Velocity in miles per hour.	Pressure per sq. foot in lbs.	Name.
0	0	0.00	Calm.
1	2	0.02	Very light breeze.
2	4	0.08	Gentle breeze.
3	12	0.75	Fresh wind.
4	25	3.00	Strong wind.
5	35	6	High wind.
6	45	10	Gale.
7	60	18	Strong gale.
8	75		Violent gale.
9	90		Hurricane.
10	100		Most violent hurricane.

571. **Mechanics of the Sail-boat.**—The action of the wind on a sail will be understood from the following. Let Fig. 641 represent the boat in horizontal projection and OS the sail, O being the mast. For simplicity we consider the sail to be a plane and to remain vertical. At this instant the boat is moving in the direction MB of its fore-and-aft line with a velocity $= c$, the wind having a velocity of the direction and magnitude represented by w (purposely taken at an angle $< 90^\circ$ with the direction of motion of the boat). We are now to inquire the nature of the action of the wind on the boat, and whether

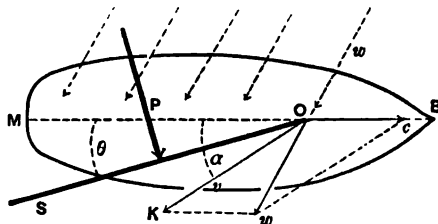

FIG. 641.

in the present position its tendency is to accelerate, or retard, the motion of the boat. If we form a parallelogram of which w is the diagonal and c one side, then the other side OK , making some angle α with BM , will be the velocity v of the wind *relatively to the boat* (and sail), and upon this (and not upon w) depends the action on the sail. The sail, being so placed that the angle θ is smaller than α , will experience pressure from the wind; that is, from the impact of the particles of air which strike the surface and glance along it. This pressure, P , is normal to the sail (considered smooth), and evidently, for the position of the parts in the figure, the component of P along MB points in the same direction as c , and hence if that component is greater than the water-resistance to the boat at this velocity, c will be accelerated; if less, c will be retarded. Any change in c , of course, gives a different form to the parallelogram of velocities, and thus the relative velocity v and the pressure P , for a given position of the sail, will both change. [The component of P \perp to MB tends, of course, to cause the boat to move laterally, but the great resistance to such movement at even a very slight lateral velocity will make the resulting motion insignificant.]

As c increases, α diminishes, for a given amount and position of w ; and the sail must be drawn nearer to the line MB , i.e. θ must be made to decrease, to derive a wind-pressure having a *forward* fore-and-aft component; and that component becomes smaller and smaller. But if the craft is an ice-boat, this small component may still be of sufficient magnitude to exceed the resistance and continue the acceleration of c until c is larger than w ; i.e., the boat may be caused to go as fast as, or faster than, the wind, and still be receiving from the latter a forward pressure which exceeds the resistance. And it is plain that there is nothing in the geometry of the figure to preclude such a relation (i.e., $c > w$, with $\theta < \alpha$ and > 0).

572. Resistance of Still Water to Moving Bodies, Completely Immersed.—This resistance depends on the shape, position, and velocity of the moving body, and also upon the roughness of its surface. If it is pointed at both ends (Fig. 642) with its

axis parallel to the velocity, v , of its *uniform* motion, the stream lines on closing together smoothly at the hinder extremity, or stern, B , exert normal pressures against the surface of the portion $CD...B$ whose longitudinal components approximately balance the corresponding components

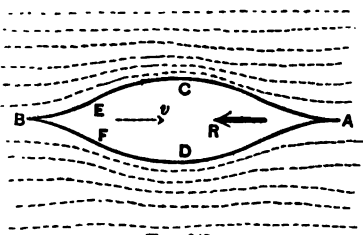

FIG. 642.

of the normal pressures on $CD...A$; so that the resistance R , which must be overcome to maintain the uniform velocity v , is *mainly due to the "skin-friction"* alone, distributed along the external surface of the body; the resultant of these resistances is a force R acting in the line AB of symmetry (supposing the body symmetrical about the direction of motion).

If, however, Fig. 643, the stern, $E..B..F$ is too bluff,

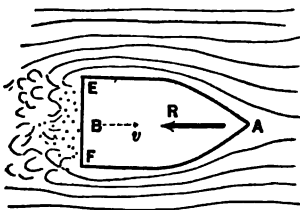

FIG. 643.

eddies are formed round the corners E and F , and the pressure on the surface $E...F$ is much less than in Fig. 642; i.e., the water pressure from behind is less than the backward (longitudinal) pressures from in front, and thus the resultant resistance R is due partly to skin-

friction and partly to "eddy-making" (§ 569).

[NOTE.—The diminished pressure on EF is analogous to the loss of pressure of water (flowing in a pipe) after passing a narrow section the enlargement from which to the original section is sudden. E.g., Fig. 644, supposing the velocity v and pressure p (per unit-area) to be the same respectively at A and A' , in the two pipes shown, with diameter $AL = WK = A'L' = W'K'$; then the pressure at M is equal to that at A (disregarding skin-friction), whereas that at

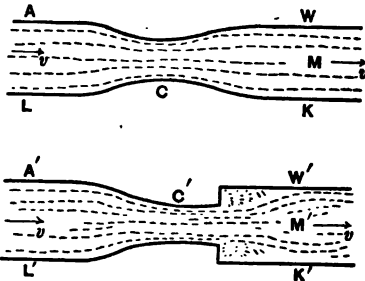

FIG. 644.

M' is considerably less than that at A' on account of the head lost in the sudden enlargement. (See also Fig. 575.)]

It is therefore evident that *bluffness of stern increases the resistance much more than bluffness of bow.*

In any case experiment shows that for a given body symmetrical about an axis and moving through a fluid (not only water, but any fluid) in the direction of its axis with a uniform velocity = v , we may write approximately the resistance

$$R = (\text{resistance at vel. } v) = \zeta F \gamma \frac{v^2}{2g} \dots (1)$$

As in preceding paragraphs, F = area of the *greatest* section, γ to axis, of the external *surface* of body (not of the substance); i.e., the sectional area of the circumscribing cylinder (cylinder in the most general sense) with elements parallel to the axis of the body. γ = the heaviness (§ 409) of the fluid, and v = velocity of motion; while ζ is an *abstract number* dependent on experiment.

According to Weisbach, who cites different experimenters, we can put for *spheres*, moving in water, ζ = about 0.55; for cannon-balls moving in water, ζ = .467.

According to Robins and Hutton, for *spheres* in *air*, we have

For v in mets. } per sec. } 1	5	25	100	200	300	400	500 } metres per sec.
$\zeta = .59$.63	.67	.71	.77	.88	.99	1.04

For musket-balls in the air, Piobert found

$$\zeta = 0.451 (1 + 0.0023 \times \text{veloc. in metres per sec.}).$$

From Dubuat's experiments, for the resistance of water to a right prism moving endwise and of length = l ,

For $(l : \sqrt{F}) = 0$	1	2	3
$\zeta = 1.25$	1.26	1.31	1.33

For a circular cylinder moving perpendicularly to its axis Borda claimed that ζ is one-half as much as for the circum-

scribing right parallelepiped moving with four faces parallel to direction of motion.

EXAMPLE.—The resistance of the air at a temperature of freezing and tension of one atmosphere to a musket-ball $\frac{1}{2}$ inch in diameter when moving with a velocity of 328 ft. per sec. is thus determined by Piobert's formula, above:

$$\zeta = 0.451(1 + .0023 \times 100) = 0.554;$$

hence, from eq. (1),

$$R = 0.554 \times \frac{\pi}{4} \left(\frac{1}{12}\right)^2 \times .0807 \times \frac{(328)^2}{64.4} = 0.1018 \text{ lbs.}$$

572a. Deviation of a Spinning Ball from a Vertical Plane in Still Air.—It is a well-known fact in base-ball playing that if a rapid spinning motion is given to the ball about a vertical axis as well as a forward motion of translation, its path will not remain in its initial vertical plane, but curve out of that plane toward the side on which the absolute velocity of an external point of the ball's surface is least. Thus, if the ball is thrown from North to South, with a spin of such character as to appear "*clock-wise*" seen from above, the ball will curve *toward the West*, out of the vertical plane in which it started.

This could not occur if the surface of the ball were perfectly smooth (there being also no adhesion between that surface and the air particles), and is due to the fact that the cushion of compressed air which the ball piles up in front during its progress, and which would occupy a symmetrical position with respect to the direction of motion of the centre of the ball if there were no motion of rotation of the kind indicated, is now piled up somewhat on the East of the centre (in example above), creating constantly more obstruction on that side than on the right; the cause of this is that the absolute velocity of the surface-points, at the same level as the centre of ball, is greatest, and the friction greatest, at the instant when they are passing through their extreme Easterly positions; since then that velocity is the *sum* of the linear velocity of translation and that of rotation; whereas, in the position diametrically oppo-

site, on the West side, the absolute velocity is the *difference*; hence the greater accumulation of compressed air on the left (in the case above imagined, ball thrown from North to South, etc.).

573. Robinson's Cup-anemometer.—This instrument, named after Dr. T. R. Robinson of Armagh, Ireland, consists of four hemispherical cups set at equal intervals in a circle, all facing in the same direction round the circle, and so mounted on a light but rigid framework as to be capable of rotating with but little friction about a vertical axis. When in a current of air (or other fluid) the apparatus begins to rotate with an accelerated velocity on account of the pressure against the open mouth of a cup on one side being greater than the resistance met by the back of the cup diametrically opposite. Very soon, however, the motion becomes practically uniform, the cup-centre having a constant linear velocity v'' the ratio of which to the velocity, v' , of the wind at the same instant must be found in some way, in order to deduce the value of the latter from the observed amount of the former in the practical use of the instrument. After sixteen experiments made by Dr. Robinson on stationary cups exposed to winds of varying intensities, from a gentle breeze to a hard gale, the conclusion was reached by him that with a given wind-velocity the total pressure on a cup with concave surface presented to the wind was very nearly four times as great as that exerted when the convex side was presented, whatever the velocity (see vol. xxii of *Transac. Irish Royal Acad., Part I.* p. 163).

Assuming this ratio to be exactly 4.0 and neglecting axle-friction, we have the data for obtaining an approximate value of m , the ratio of v' to the observed v'' , when the instrument is in use. The influence of the wind on those cups the planes of whose mouths are for the instant \parallel to its direction will also be neglected.

If, then, Fig. 645, we write the *impulse* on a cup when the hollow is presented to the wind [§ 572, eq. (1)]

$$P_h = \zeta_h F \gamma \frac{v_i^2}{2g}, \quad (1)$$

and the *resistance* when the convex side is presented

$$P_o = \zeta_o F \gamma \frac{v_a^2}{2g}, \dots \dots \dots (2)$$

we may also put

$$\zeta_h = 4\zeta_o. \dots \dots \dots (3)$$

In (1) and (2) v_1 and v_2 are relative velocities.

Regarding only the two cups *A* and *B*, whose centres at a definite instant are moving in lines parallel to the direction of the wind, it is evident that the motion of the cups does not become uniform until the relative velocity $v' - v''$ of the wind and cup *A* (retreating before the wind) has become so small, and the relative velocity $v' + v''$ with which *B* advances to meet the air-particles has become so great, that the impulse of the wind on *A* equals the resistance encountered by *B*; i.e., these forces, P_h and P_o , must be equal, having equal lever-arms about the axis. Hence, for uniform rotary motion,

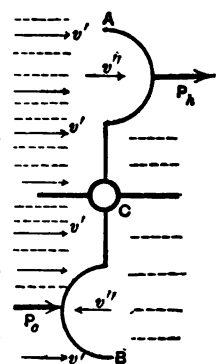

$$\zeta_h F \gamma \frac{(v' - v'')^2}{2g} = \zeta_o F \gamma \frac{(v' + v'')^2}{2g}; \dots \dots (4)$$

i.e. [see eq. (3)],

$$4 \left[\frac{v'}{v''} - 1 \right]^2 = \left[\frac{v'}{v''} + 1 \right]^2; \text{ or, } 4(m - 1)^2 = (m + 1)^2. \dots (5)$$

Solving the quadratic for m , we obtain

$$m = 3.00. \dots \dots \dots (6)$$

That is, the velocity of the wind is about three times that of the cup-centre.

574. **Experiments with Robinson's Cup-anemometer.**—The ratio 3.00 just obtained is the one in common use in connection with this instrument in America. Experiments by Mr.

Hazen at Washington in 1886 (*Am. Jour. Science*, Oct. '87, p. 248) were made on a special type devised by Lieut. Gibbon. The anemometer was mounted on a whirling machine at the end of a 16-ft. horizontal arm, and values for m obtained, with velocities up to 12 miles per hour, from 2.84 to 3.06; average 2.94. The cups were 4 in. in diameter and the distance of their centres from the axis 6.72 in., these dimensions being those usually adopted in America. This instrument was nearly new and was well lubricated.

Dr. Robinson himself made an extensive series of experiments, with instruments of various sizes, of which an account may be found in the *Philos. Transac.* for 1878, p. 797 (see also the volume for 1880, p. 1055). Cups of 4 in. and also of 9 in. were employed, placed first at 24 and then at 12 in. from the axis. The cup-centres revolved in a (moving) vertical plane perpendicular to the horizontal arm of a whirling-machine; this arm, however, was only 9 ft. long. A friction-brake was attached to the axis of the instrument for testing the effect of increased friction on the value of m . At high speeds of 30 to 40 miles per hour (i.e., the speed of the centre of the instrument in its horizontal circle, representing an equal speed of wind for an instrument in actual use with axis stationary) the effect of friction was relatively less than at low velocities. That is, at high speeds with considerable friction the value of m was nearly the same as with little friction at low speeds. With the large 9 in. cups at a distance of either 24 or 12 in. from the axis the value of m at 30 miles per hour ranged generally from 2.3 to 2.6, with little or much friction; while with the minimum friction m rose slowly to about 2.9 as the velocity diminished to 10 miles per hour. At 5 miles per hour with minimum friction m was 3.5 for the 24 in. instrument and about 5.0 for the 12 in. The effect of considerable friction at low speeds was to increase m , making it as high as 8 or 10 in some cases. With the 4 in.-cups no value was obtained for m less than 3.3. On the whole, Dr. Robinson concluded that m is more likely to have a constant value at all velocities the larger the cups, the longer the arms, and the less the friction, of the anemometer. But few straight-line experi-

ments have been made with the cup-anemometer, the most noteworthy being mentioned on p. 308 of the *Engineering News* for October 1887. The instrument was placed on the front of the locomotive of a train running between Baltimore and Washington on a calm day. The actual distance is 40 miles between the two cities, while from the indications of the anemometer, assuming $m = 3.00$, it would have been in one trip 46 miles and in another 47. The velocity of the train was 20 miles per hour in one case and 40 in the other.

575 Other Anemometers.—Both Biram's and Castello's anemometers consist of a wheel furnished with radiating vanes set obliquely to the axis of the wheel, forming a small "wind-mill," somewhat resembling the current-meter for water shown in Fig. 604; having six or eight blades, however. The wheel revolves with but little friction, and is held in the current of air with its axis parallel to the direction of the latter, and very quickly assumes a steady motion of rotation. The number of revolutions in an observed time is read from a dial. The instruments must be rated by experiment, and are used chiefly in measuring the velocity of the currents of air in the galleries of mines, of draughts of air in flues and ventilating shafts, etc.

To quote from vol. v of the Report of the Geological Survey of Ohio, p. 370: "Approximate measurements (of the velocity of air) are made by miners by flashing gunpowder, and noting with a watch the speed with which the smoke moves along the air-way of the mine. A lighted lamp is sometimes used, the miner moving along the air-gallery, and keeping the light in a perfectly perpendicular position, noting the time required to pass to a given point."

Another kind makes use of the principle of Pitot's Tube (p. 751), and consists of a U-tube partially filled with water, one end of the tube being vertical and open, while the other turns horizontally, and is enlarged into a wide funnel, whose mouth receives the impulse of the current of air; the difference of level of the water in the two parts of the U is a measure of the velocity.

576. Resistance of Ships.—We shall first suppose the ship to be towed at a uniform speed; i.e., to be without means of self-propulsion (under water). This being the case, it is found that at moderate velocities (under six miles per hour), the ship being of “*fair*” form (i.e., the hull tapering both at bow and stern, under water) the resistance in still water is almost wholly due to *skin-friction*, “*eddy-making*” (see § 569) being done away with largely by avoiding a bluff stern.

When the velocity is greater than about six miles an hour the resistance is much larger than would be accounted for by skin-friction alone, and is found to be connected with the surface-disturbance or waves produced by the motion of the hull in (originally) still water. The recent experiments of Mr. Froude and his son at Torquay, England, with models, in a tank 300 feet long, have led to important rules (see Mr. White’s *Naval Architecture* and “Hydromechanics” in the *Ency. Britann.*) of so proportioning not only the total length of a ship of given displacement, but the length of the *entrance* (forward tapering part of hull) and length of *run* (hinder tapering part of hull), as to secure a minimum “*wave-making resistance*,” as this source of resistance is called.

To quote from Mr. White (p. 460 of his *Naval Architecture*, London, 1882): “Summing up the foregoing remarks, it appears:

“(1) That *frictional resistance*, depending upon the area of the immersed surface of a ship, its degree of roughness, its length, and (about) the square of its speed, is not sensibly affected by the forms and proportions of ships; unless there be some unwonted singularity of form, or want of fairness. For *moderate speeds* this element of resistance is by far the most important; for high speeds it also occupies an important position—from 50 to 60 per cent of the whole resistance, probably, in a very large number of classes, when the bottoms are *clean*; and a larger percentage when the bottoms become foul.

“(2) That *eddy-making resistance* is usually small, except in special cases, and amounts to 8 or 10 per cent of the frictional

resistance. A defective form of stern causes largely increased eddy-making.

“(3) That *wave-making resistance* is the element of the total resistance which is most influenced by the forms and proportions of ships. Its ratio to the frictional resistance, as well as its absolute magnitude, depend on many circumstances; the most important being the forms and lengths of the entrance and run, in relation to the intended full speed of the ship. For every ship there is a limit of speed beyond which each small increase in speed is attended by a disproportionate increase in resistance; and this limit is fixed by the lengths of the entrance and run—the ‘wave-making features’ of a ship.

“The sum of these three elements constitutes the total resistance offered by the water to the motion of a ship towed through it, or propelled by sails; in a steamship there is an ‘*augment*’ of resistance due to the action of the propellers.”

In the case of a steamship driven by a screw propeller, this *augment* to the resistance varies from 20 to 45 per cent of the “tow-rope resistance,” on account of the presence and action of the propeller itself; since its action relieves the stern of some of the *forward* hydrostatic pressure of the water closing in around it. Still, if the screw is placed far back of the stern, the *augment* is very much diminished; but such a position involves risks of various kinds and is rarely adopted.

We may compute approximately the resistance of the water to a ship propelled by steam at a uniform velocity v , in the following manner: Let L denote the power developed in the engine cylinder; whence, allowing 10 per cent of L for engine friction, and 15 per cent for “work of slip” of the propeller-blade, we have remaining $0.75L$, as expended in overcoming the resistance R through a distance $= v$ each unit of time; i.e.,

$$(\text{approx.}) \quad 0.75L = Rv. \quad . \quad . \quad . \quad . \quad . \quad . \quad (1)$$

EXAMPLE.—If 3000 indicated H. P. (§ 132) is exerted by the engines of a steamer at a uniform speed of 15 miles per hour

(= 22 ft. per sec.), we have (with above allowances for slip and engine friction) [foot-lb.-sec.]

$$\frac{1}{4} \times 3000 \times 550 = R \times 22; \therefore R = 56250 \text{ lbs.}$$

Further, since R varies (roughly) as the *square* of the velocity, and can therefore be written $R = (\text{Const.}) \times v^2$, we have from (1)

$$L = a \text{ constant} \times v^3 \dots \dots \dots (2)$$

as a roughly approximate relation between the speed and the power necessary to maintain it uniformly. In view of eq. (3) involving the *cube* of the velocity as it does, we can understand why a large increase of power is necessary to secure a proportionally small increase of speed.

577. "Transporting Power," or Scouring Action, of a Current.
 —The capacity or power of a current of water in an open channel to carry along with it loose particles, sand, gravel, pebbles, etc., lying upon its bed was investigated experimentally by Dubuat about a century ago, though on a rather small scale. His results are as follows:

The velocity of current must be at least

0.25	ft. per sec.,	to transport	silt;
0.50	"	"	loam;
1.00	"	"	sand;
2.00	"	"	gravel;
3.5	"	"	pebbles 1 in. in diam.;
4.0	"	"	broken stone;
5.0	"	"	chalk, soft shale.

However, more modern writers call attention to the fact that in some instances beds of sand are left undisturbed by currents of greater velocity than that above indicated for sand, and explain this fact on the theory that the water-particles may not move parallel to the bed, but in cycloids, approximately, like the points in the rim of a rolling wheel, so as to have little or no scouring action on the bed in those cases.

In case the particles move in filaments or stream-lines parallel to the axis of the stream the statement is sometimes made that *the "transporting power" varies as the sixth power*

of the velocity of the current, by which is meant, more definitely, the following: Fig. 646. Conceive a row of cubes (or other solids geometrically similar to each other) of many sizes, all of the same heaviness (§ 7), and similarly situated, to be placed on the horizontal bottom of a trough and there exposed to a current of water, being completely immersed.

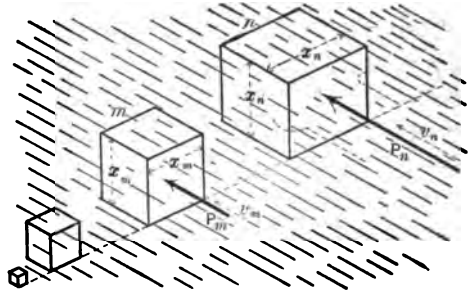

FIG. 646.

Suppose the coefficient of friction between the cubes and the trough-bottom to be the same for all. Then, as the current is given greater and greater velocity v , the impulse P_m (corresponding to a particular velocity v_m) against some one, m , of the cubes, will be just sufficient to move it, and at some higher velocity v_n the impulse P_n against some larger cube, n , will be just sufficient to move it, in turn. We are to prove that $P_m : P_n :: v_m^3 : v_n^3$.

Since, when a cube barely begins to move, the impulse is equal to the friction on its base, and the frictions under the cubes (when motion is impending) are proportional to their volumes (see above), we have therefore

$$\frac{P_m}{P_n} = \frac{x_m^3}{x_n^3} \dots \dots \dots (1)$$

Also, the impulses on the cubes, whatever the velocity, are proportional to the face areas and to the squares of the velocities (nearly; see § 572); hence

$$\frac{P_m}{P_n} = \frac{v_m^2 x_m^2}{v_n^2 x_n^2} \dots \dots \dots (2)$$

From (1) and (2) we have

$$\frac{v_m^3}{v_n^3} = \frac{x_m}{x_n}; \text{ i.e., } \frac{x_m^3}{x_n^3} = \frac{v_m^3}{v_n^3}; \dots \dots (3)$$

while from (3) and (2) we have, finally,

$$P_m : P_n :: v_m^4 : v_n^4 \dots \dots \dots (4)$$

Thus we see in a general way why it is that if the velocity of a stream is doubled its transporting power is increased about sixty-four-fold; i.e., it can now impel along the bottom pebbles that are sixty-four times as heavy as the heaviest which it could move before (of same shape and heaviness).

Though rocks are generally from two to three times as heavy as water, their loss of weight under water causes them to encounter less friction on the bottom than if not immersed.

578. **Recent Experiments with Fire-hose, Nozzles, etc.** (Addendum to § 520.)—The very full and careful investigations of Mr. J. R. Freeman, hydraulic engineer of Boston, Mass., in this line (see *Transac. A. S. C. E.*, Nov. 1889) furnish the following results: By taking piezometer readings at the ends of a portion of fire-hose conducting a steady flow of water, the values of loss of pressure due to fluid friction per 100 feet of length could be computed; a careful measurement being also made of the diameter of the hose and of the volume of water transmitted in an observed time. The table here given presents results applicable to hose of exactly 2.5 inches diameter, for a delivery of water at the rate of 240 gallons per minute (that is, for a velocity in the hose of 15.68 ft. per sec.). (The value of *f* has been computed by the writer.)

Sample.	Description.	Loss of pressure, per 100 ft. of length, in lbs. per sq. in.	Coefficient <i>f</i> . (See § 520.)	Velocity of water in hose.
L	Unlined linen hose.....	33.2	0.01045	15.68
K	Woven cotton, rubber-lined, "Mill Hose".....	25.5	0.00802	15.68
I	K. cotton, rubber-lined, hose.	19.4	0.00610	15.68
E	Ditto, but interstices between threads well filled.....	16.0	0.00508	15.68
C	Woven cotton, rubber-lined, hose. So well filled with the rubber that the inner surface remained smooth under pressure.....	14.1	0.00443	15.68

It was found that with other rates of flow the friction-head varied nearly as the square of the velocity. The great importance of a smooth interior of hose is well shown by this table.

A short section of each kind of hose was filled with liquid plaster *under pressure*. After the setting of the plaster the hose was removed and photographs taken of the cast, thus conveying a definite idea of the degree of roughness of interior of hose.

As to nozzles, it was found that the plain conical nozzle gave the best results, jets from the ring-nozzles being slightly inferior in range.

By means of a very delicate form of Pitot's tube measurements were made of the velocity in different parts of the section of jets, near the nozzle, with the interesting result that in "about two-thirds the whole distance from centre to circumference the velocity remains the same as at centre," and that at $\frac{1}{2}$ inch from the wall of most of the orifices the velocity was only 5% less than at centre of jet. With a jet from a 5-foot length of brass tubing $1\frac{1}{2}$ inch in diameter and used as a nozzle the velocity fell off rapidly for filaments further from the centre; e.g., at half the distance from centre to circumference the velocity was 90% of that at the centre, and at the outside edge 60%. Most of the nozzles ranged from 1 in. to $1\frac{1}{2}$ in. in diameter of orifice.

By using these velocity measurements to "gauge" the flow it was found that the relation $h' = \frac{c^2}{2g}$ was quite closely borne out (within 1%) (see eq. (7)'', p. 804). The point of the Pitot tube was conically convergent, its extremity being 0.017 in. in external diameter and containing an orifice of 0.006 in. diameter. A minute passage-way led from the orifice to a Bourdon gauge.

Based on his experiments, Mr. Freeman gives tables for the maximum vertical height, V , and also the maximum horizontal range, H , of "good effective fire-streams" delivered from smooth conical nozzles of various sizes and with different piezometer pressures p (in lbs. p. sq. in. above atmosphere) at the base of play-pipe, the gauge being at same level as nozzle. (The distances reached by the extreme drops are very much greater with the high pressures. V and H are in feet.)

The following is a brief synopsis of this table. d is the internal diameter of the extremity of nozzle. The maximum horizontal range was obtained at an angle of elevation of about 32° .

For $p =$	10		20		40		60		80		100	
	V	H	V	H	V	H	V	H	V	H	V	H
$d = \frac{3}{8}$ in.	17 ft.	19	33	29	60	44	72	54	79	62	83	68
$d = \frac{7}{16}$ "	18	21	34	33	62	49	77	61	85	70	90	76
$d = 1$ "	18	21	35	37	64	55	79	67	89	76	96	82
$d = 1\frac{1}{8}$ "	18	22	36	38	65	59	82	72	92	81	99	89
$d = 1\frac{1}{4}$ "	19	22	37	40	67	63	85	76	95	85	101	93
$d = 1\frac{3}{8}$ "	20	23	38	43	69	66	87	79	97	88	103	96

579. Addendum on the Pelton Water-wheel.—The annexed cut and additional details of the test alluded to on p. 810 are taken from circulars of the manufacturers, of San Francisco, Cal.

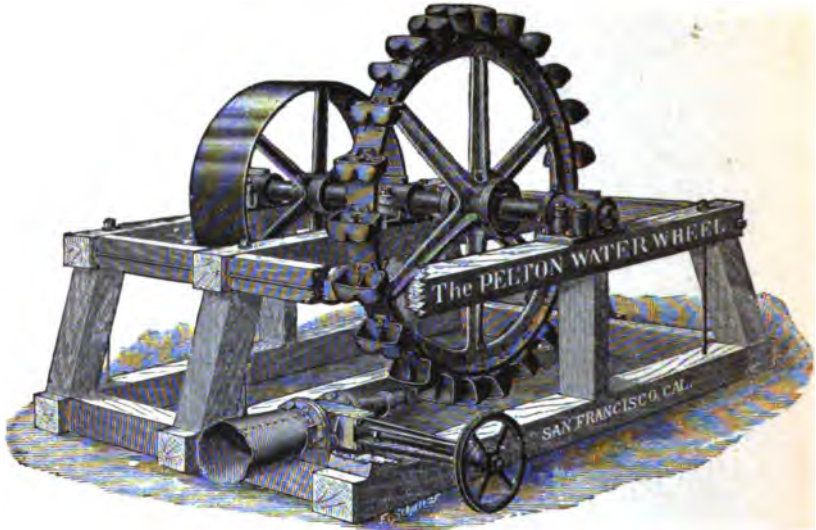

The water was measured over an iron weir $\frac{1}{4}$ " thick and 3.042 feet long without end contraction.

The depth was measured by a Boyden hook gauge reading to .001", and was .4146 foot. The quantity of water discharged was found to be 2.819 cubic feet per second—Fteley's formula. The head lost by friction in pipe was 1.8 feet, reducing the effective head to 384.7 feet.

The work done was measured by a Prony brake bearing vertically down upon a platform scale and which showed a weight of 200 pounds upon the scale-beam when the brake gear was suspended by a cord from a point immediately above the wheel-shaft. This made a constant minus correction of 200 pounds. The friction pulley had a face of 12", and being kept wet by a jet of clear cold water, it developed very little heat and ran without much jumping. Thirteen tests were made showing very uniform results, the first four of which were as follows :

Tests.	Weight shown by scale.	Net weight (-200 lbs.)	Rev. wheel-shaft per min.	
1	665	$G = 465$	$u = 254\frac{1}{2}$	$Gu = 118342$
2	665	465	255	118575
3	660	460	256	117780
4	660	460	256 $\frac{1}{2}$	117980
			Totals 1.022	473677
			Means 255 $\frac{1}{4}$	118167

The arm of the Prony brake was 4.775 feet from centre of wheel-shaft to point of contact on scale and hence described a circle with a circumference of 30 feet. The work done per minute was therefore $Gu(2\pi r) = (118167 \times 30)$ or 3,545,000 foot-pounds, equal to 107.4 horse-power. The theoretical power of the water was $(2.819 \times 60 \times 384.7 \times 62.4)$ or 4,060,253 foot-pounds. The useful effect was therefore 87.3 per cent.

INDEX TO MECHANICS OF SOLIDS.

(For Index to "Hydraulics" see p. xxii.)

Page.	Page.
<p>Aberration of Light..... 90 Absolute Velocity..... 89 Abutment-Line..... 414 Abutments of Arches.... 490, 435 Acceleration, Angular..... 107 Acceleration, Linear... 49 Acceleration, Normal..... 75, 77 Acceleration of Gravity 51, 160, 179 Acceleration, Tangential... 74, 80 Action and Reaction..... 1, 53 Angular, or Rotary, Motion.. 107 Anomalies in Friction..... 192 Anti-Derivative, see Preface and p. 258 Anti-Resultant..... 402 Anti-Stress-Resultant..... 411 Apparent Weight..... 78, 79 Arches Linear..... 386, 396 Arches of Masonry..... 421, 437 Arch-Ribs..... 438, 433 Arch-Ribs, Classification of... 458 Arch-Rib of Three Hinges. 458, 460 Arch-Rib of Hinged Ends 440, 458, 461 Arch-Rib of Fixed Ends 439, 459, 465 Arch Truss, or Braced Arch... 478 Atwood's Machine..... 159 Autographic Testing Machine. 240 Beams, Rectangular, Compar- ative Strength and Stiffness 272, 273, 277 Belting, Pressure of..... 181 Belting, slip of..... 182 Bent Lever with Friction.... 173 Boat-Rowing..... 160 Bow's Notation..... 497 Box-Girder..... 275, 292 Braced Arch..... 438, 478 Brake, Prony..... 158 Brakes, Railroad..... 190 Bridge, Arch..... 430 Bridge-Pier..... 141 Bridge, Suspension..... 46 Bridge Truss, Warren..... 35 Buckling of Web-Plates..... 383 Built Beams, designing Sec- tions of..... 295 Built Columns..... 378 Burr, Prof., Citations from. 224, 229 Butt-Joint..... 226</p>	<p>Cantilevers..... 260, 276, 341 Cantilever, Oblique..... 353, 356 Catenary, Common..... 46 Catenary Inverted..... 367 Catenary, Transformed..... 395 Cast Iron..... 220, 279 Cast Iron, Malleable..... 224 Centre of Gravity, 18, 19, etc... 336 Centre of Oscillation..... 119 Centre of Percussion of Rod... 111 Centrifugal Action..... 125 Centrifugal Force..... 77, 78 Centripetal Force..... 77, 78, 79 Centrobatic Method..... 24 <i>Cheval-Vapeur</i>..... 186 Chrome Steel..... 224 Circle as Elastic Curve.... 262, 343 Circular Arc as Linear Arch.. 391 Closing Line..... 414 Coblenz, Bridge at..... 459, 478 Columns, Long..... 363 Composition of Forces... 4, 8, 31, 38 Compression of Short Blocks.. 218 Concurrent Forces..... 6, 8, 397 Cone of Friction..... 168 Conical Pendulum..... 78 Connecting-Rod..... 59, 69, 70 Conservation of Energy..... 156 Conservation of Momentum... 66 Continuous Girders, by Analysis 320—332 Continuous Girders, by Graphics..... 484—514 Copying-Press..... 71 Cords, Flexible..... 42 Cords, Rigidity of..... 192 Couples..... 27, 30 Cover-Plates..... 226 Crane..... 362 Crank-Shaft, Strength of..... 314 Creeping of Belts..... 186 Crushing, Modulus of... 219, 424 Curvilinear Motion..... 72 Dangerous Section..... 262, 332 Dash-Pot..... 158 Deck-Beam..... 275 Deflections, (Flexure) 252—262, 342 Derivatives, (Elastic curve)... 310 Derived Quantities..... 2 Deviating Force..... 77</p>

(For index to "Hydraulics" see p. xxii.)

Diagrams, Strain.....	209, 241	"Fixed Points".....	503
Displacement of Point of Arch		Flexural Stiffness.....	250
Rib.....	447	Flexure.....	244—386
Dove-Tail Joint.....	269	Flexure and Torsion Combined	314
Duchayla's Proof of the Parallelo-		Flexure, Beams of Uniform	
gram of Forces.....	4	Strength.....	335
Dynamics, Definition.....	4	Flexure, Common Theory.....	244
Dynamics of a Rigid Body.....	105	Flexure, Eccentric Load... 256, 301	
Dynamics of Material point... 49		Flexure, Elastic Curves in... 245,	
Dynamometers..... 157, 158, 159	 251, 252—262	
Eddy, Prof., Graphic Methods,		Flexure, Examples in... 230—284	
(See Preface).....	426	Flexure, Hydrostatic Pressure	308
Elastic Curve a Circle... 262, 343		Flexure, Moving Loads.....	298
Elastic Curve an Equilibrium		Flexure, Non-Prismatic	
Polygon.....	484	Beams.....	332, 335
Elastic Curves... 245, 252—262, 356		Flexure of Long Columns....	363
Elastic Curves, the Four x -De-		Flexure of Prismatic Beams	
rivatives of.....	810	Under Oblique Forces... 347—362	
Elasticity-Line.....	241	Flexure, Safe Loads in... 262—284	
Elasticity, Modulus of... 208, 227		Flexure, Safe Stress in.....	279
Elastic Limit.....	202	Flexure, Shearing Stress in	
Elevation of Outer Rail on Rail-		284—295
road Curves.....	78	Flexure, Special Problems	
Ellipse of Inertia.....	94	in.....	295—319
Ellipsoid of Inertia.....	104	Flexure, Strength in... 249	
Elliptical Beam.....	840	Flexure, the Elastic Forces... 246	
Elongation of Wrought-Iron		Flexure, the "Moment".....	249
Rod.....	207	Flexure, the "Shear".....	248
Energy.....	137	Flexure, Uniform Load... 258, 267	
Energy, Conservation of.....	156	302, 305, 307, 324, 329, 340	
Energy, Kinetic... 137, 144, 147, 150		Flow of Solids.....	213
Energy, Potential.....	155	Fly-Wheel.....	121, 151
Equations, Homogeneous.....	2	Fly-Wheel, Stresses in... 126, 127	
Equator, Apparent Weight at the 78		Force.....	1
Equilibrium.....	4, 33, 39	Force Diagram.....	400
Equilibrium Polygon... 401, 450		Force Polygons.....	397
Equilibrium Polygon Through		Forces, Concurrent.....	6, 8
Three Points.....	418, 419	Forces, Distributed.....	197
Equivalent Systems... 7, 105, 145		Forces, Non-Concurrent.. 6, 31	
Exaggeration of Vertical Di-		Forces, Parallel.....	13
mensions in Arch-Ribs... 470		Forces, Parallelogram of.....	4
Examples in Flexure... 280—284		Forces, Varieties of.....	7
Examples in Shearing... 231, 232		Free Axes.....	129
Examples in Tension and		Free-Body Method, the... 11, 105	
Compression.....	222, 223	Friction.....	164—194, 422, 423
Examples in Torsion... 241—243		Frictional Gearing.....	172
Experiments of an English		Friction, Anomalies in... 192	
Railroad Commission.....	314	Friction Axle.....	175
Experiments of Hodgkinson		Friction Brake.....	168
.....	207, 369	Friction, Cone of.....	163
Experiments of Prof. Lanza... 280		Friction in Machinery.....	191
Experiments on Building Stone	424	Friction, Sliding.....	164—168
Experiments on Columns... 378		Friction of Pivots.....	179
Extrados.....	421	Friction, Rolling.....	186
Euler's Formula for Columns... 364		Friction-Wheels.....	177
Factor of Safety.....	223	Friction, Work Spent in... 149	
Falling Bodies.....	51	General Properties of Materials	
"False Polygons".....	497, 501	204
Fatigue of Metals.....	224	Governor Ball.....	78

(For index to "Hydraulics" see p. xxii.)

Graphic Representations of Uniformly Accelerated Motion.	57	Mechanics, Divisions of.	4
Graphic Treatment of Arch.	431	Middle Third.	428
Gravity, Acceleration of 51, 79, 160		Modulus of Elasticity.	208, 227
Gravity, Centre of.	18, 386, 453	Modulus of Resilience.	213
Gravity-Vertical.	453	Modulus of Rupture (Flexure) 278	
Graphical Statics, Elements of.	397—420	Modulus of Tenacity.	213
Graphical Statics of Vertical Forces.	412—420	Moduli of Compression.	219
Guide Curve.	83	Mohr's Theorem.	486
Gyroscope.	132	Moment-Area.	485
Harmonic Motion.	58, 81, 117	Moment of a Force.	14
Heat Energy.	156	Moment-Diagram.	288
Heaviness, Table, Etc.	3	Moment of Flexure.	248, 348, 351
Height Due to Velocity.	52, 84	Moment of Inertia.	91
Hodgkinson's Formulæ for Columns.	369	Moment of Inertia by Graphics 454	
Homogeneous Equations.	2	Moment of Inertia of Box-Girder.	276
Hooke's Law.	201, 208, 207	Moment of Inertia of Built Beam.	296
Hooks, Strength of.	362	Moment of Inertia of Built Column.	379
Horizontal Straight Girders by Graphics.	479—483	Moment of Inertia of Plane Figures.	91—98, 249, 274
Horse-Power.	186, 239, 242	Moment of Inertia of Rigid Bodies.	98, 108
I-Beam.	275, 292, 295, 337	Moment of Inertia of Truss.	478
Ice-Boat, Speed of.	90	Moment of Torsion.	236
Impact.	63	Momentum.	66
Impact, Loss of Energy in.	141	Mortar.	422
Inclined Beam.	359	Motion, Curvilinear.	72
Inclined Plane 83, 185, 151, 166, 169		Motion, Rectilinear.	50
Indicator.	159	Motion, Rotary.	107
Inertia.	53	Moving Loads (Flexure.	298
Inertia of Piston-Rod.	59	Naperian Base.	183, 357, 387
Instantaneous Rotation, Axis of.	112	Naperian Logarithms.	47
Internal Stress, General Problem of.	205	Navier's Principle.	422, 486
Intrados.	421	Neutral Axis.	245, 247, 347, 355
Isochronal Axes.	120	Neutral Line (see Elastic Curve.)	
Isotropes.	204	Newton's Laws.	1, 53
Kinetic Energy.	137, 144, 147, 150	Non-Concurrent Forces in a Plane.	31, 399
Knot, Fixed.	43	Non-Concurrent Forces in Space 37	
Knot, Slip.	43	Normal Acceleration.	75, 76, 77
Lanza, Experiments of Prof.	280	Normal Stress.	200
Lateral Contraction.	211, 229	Oblique Section of Rod in Tension.	200
Lateral Security of Girders 230, 238		Parabola as Linear Arch.	391
Lever.	18, 71	Parabolic Cord.	45
Lever, Bent, With Friction 173, 174		Parabolic Working-Beam. 336, 344	
Linear Arches.	386—396, 417, 425	Parallel Forces.	13
Live Loads.	298, 430	Parallel-Rod of Locomotive.	131
Load-Line.	413	Parallelogram of Forces.	4
Locomotive on Arch.	430	Parallelogram of Motions.	72
Locomotive on Girder.	298	Parallelogram of Velocities.	72
Locomotive, Parallel-Rod of.	131	Pendulum, Compound.	113
Malleable Cast Iron.	224	Pendulum, Conical.	78
Mass.	2, 53	Pendulum, Cycloidal.	80
Material Point.	3	Pendulum, Simple Circular.	81
Mechanical Equivalent of Heat 156		Phoenix Columns.	378
Mechanics, Definition of.	1	Pier Reactions.	404

(For index to "Hydraulics" see p. xxii.)

Piers of Arches	430, 485	Shafts, Non-Circular.....	289
Pile-Driving.....	140	Shear Diagram (Flexure).....	265
Pillars (see columns)		Shearing.....	225-233
"Pin-and-Square" Columns...	364	Shearing Distortion.....	227
Planet, Velocity of.....	82	Shear, Distribution of in Flexure.....	287
Polar Moment of Inertia.....	97, 288	Shearing Forces.....	7, 225
Pole (in Graphics).....	401	Shearing Stress,	
Pole-Distance.....	416, 417	7, 200, 201, 225, 284, 284
Practical Notes.....	223	Shear, the First α -Derivative of Moment (Flexure).....	264
Potential Energy.....	155	Skidding.....	190
Power.....	184	Slip (of Oar, etc.).....	161
Power of Motors.....	153, 157, 158	Slope (in Flexure).....	253
Power, Transmission of, by Belting.....	184	Soft.....	421
Power, Transmission of by Shafts.....	288, 318	Spandrel.....	421
Principal Axes.....	104, 129	Special Equilibrium Polygon.....	409, 424, 440
Projectile in Vacuo.....	83, 84-87	Specific Gravity.....	3
Prony Friction Brake.....	158	Statics, Definition of.....	4
Pulley.....	43, 103	Statics, Graphical.....	397-420
Punching Rivet Holes.....	229	Statics of a Material Point.....	8
Quantity, Kinds of.....	1	Statics of a Rigid Body.....	27
Quantities, Derived.....	2	Statics of Flexible Cords.....	43
Radius of Curvature, 75, 76,	250, 353	Steam Engine Problems... 55,	61, 69, 70, 121, 131, 151
Radius of Gyration 91, 92, 115,	313, 376	Steam Hammer.....	193
Rankine's Formula for Columns.....	372, 375	Stiffening of Web-Plates.....	383
Rays of Force Diagram.....	401	Stone, Strength of.....	221, 424
Reaction.....	1, 18, 36, 53, 404	Stress Diagrams for Arch-Ribs.	471
Reduced Load-Contour.....	429	Stresses Due to Rib Shortening.....	476
Regulation of Machines.....	153	Strain Diagrams.....	209, 241
Relative and Absolute Velocities.....	89	Strains, two kinds only.....	196
Resilience.....	204, 213, 237, 251, 313	Stress.....	197, 198
Resultant of Parallel Forces, 13, 15		Stress and Strain, Relation Between.....	201
Resultant of Two or More Forces.....	4, 6	Stress-Couple.....	253, 343
Reversal of Stress.....	514	Stress, Normal and Shearing... 200	
Rigid Body.....	4	Strength of Materials.....	195
Rigidity of Ropes.....	192	Stretching of a Prism Under its Own Weight.....	215
Riveting for Built Beams.....	292	"Sudden" Application of a Load.....	214, 255
Rivets and Riveted Plates. 225, 292		Summation of Products by Graphics.....	451
Robinson, Prof., Integration by	857	Suspension Bridge.....	46
Rod in Tension.....	198, 200	Table for Flexure.....	279
Rolling Friction.....	186	Table for Shearing.....	228
Rolling Motion.....	130	Tables for Tension and Compression.....	221
Roof Truss.....	37, 405	Tackle.....	43
Rotary Motion.....	68, 107, 129	Temperature Stresses 206, 217,	222, 478
Rotation and Translation Combined.....	190, 150	Tenacity, Moduli of.....	212
Rupture.....	202	Testing Machine, Autographic	240
Safe Limit of Stress.....	202	Theorem of Three Moments....	333
Safe Loads in Flexure.....	262, 284	Thrust (in Flexure).....	348, 350
St. Louis Bridge.....	459, 467, 478	Torsion.....	233-248
Schiele's "Anti-Friction" Pivots	181		
Set, Permanent... 202, 209, 203, 241			
Shafts.....	233-239		

INDEX TO MECHANICS OF SOLIDS.

xxi

(For index to "Hydraulics" see p. xxii.)

Torsion, Angle of.....	233	Units, Proper Use.....	see § 6, p. 2
Torsion Balance.....	116	Velocity, Absolute.....	89
Torsion, Helix Angle in.....	233	Velocity, Angular.....	107
Torsion, Moment of.....	236	Velocity, Linear.....	49
Torsional Resilience.....	237	Velocity, Relative.....	89
Torsional Stiffness.....	236	Virtual Moment.....	67
Torsional Strength.....	235	Virtual Velocities.....	67
Tractrix, The.....	181	Voussoir.....	386, 421
Transformed Catenary.....	395	Warren Bridge Truss.....	35
Transmission of power by		Water, Jets of.....	87
Belting.....	184	Web of I-Beam.....	274
Transmission of Power by Shafting		Web of I-Beam, Buckling of..	333
.....	238, 318	Web of I-Beam, Shear in.....	290
Translation, Motion of.....	68,	Wedge, with Friction.....	171
.....	105, 106, 133,	Weight.....	2, 3, 7, 79
.....	187	Weight, Apparent.....	78, 79
Trussed Girders.....	381	Wind and Sail-Boat.....	89, 90
Uniformly Accelerated Motion		Work.....	133, 134, etc.
.....	54, 107	Work and Energy in Machines	
Uniform Motion.....	48, 107, 129	146, 147, etc.
Uniform Strength, Beams of..	333	Working-Beam.....	336, 344
Uniform Strength, Solid of, in		Working Strength.....	202
Tension.....	216		

INDEX TO HYDRAULICS.

(For index to "Mechanics of Solids" see p. xvii.)

	PAGE		PAGE
Absolute Temperature.....	606	Bernoulli's Theorem with Friction.....	696
Absolute Zero ..	606	Bidone, Experiments on Jets... ..	803
Accumulator, Hydraulic.....	700	Blowing-engine, Test.....	776
Adiabatic Change, 621, 629, 631, 636	636	Borda's Formula.....	722
Adiabatic Expansion in Compressed-air Engine.....	631	Bourdon Steam-gauge.....	532
Adiabatic Flow of Gases from an Orifice.....	778	Boyle's Law ..	615
Air Collecting in Water-pipes, 731, 736	736	Bramah Press ..	526
Air, Compressed, Transmission of.....	786-790	Branching Pipes.....	736
Air-compressor.....	636	Brayton's Petroleum-engine ...	641
Air-profile.....	749	Buoyant Effort.....	586
Air-pump, Sprengel's.....	656	Buoyant Effort of the Atmosphere.....	644
Air-thermometer.....	604	Canal Lock, Time of Filling, 739, 740	740
Amplitude of Backwater.....	772	Centigrade Scale.....	605
Anemometer, Robinson's... 824, 826	826	Centre of Buoyancy.....	586
Anemometer, Biram's.....	827	Centre of Pressure.....	546
Anemometer, Castello's.....	827	Change of State of Gas.....	610
Angle of Repose.....	572	Chézy's Formula ..	714
Angular Stability of Ships... ..	597	Chézy's Formula for Open Channels.....	758
Atkinson Gas-engine..... 642, 648	648	Church and Fteley, Report on Quaker Bridge Dam, 558, 568, 564	564
Atmosphere as a Unit Pressure, 519	519	Clearance ..	627
Augment of Resistance of Screw Propeller.....	829	Closed Air-manometer.....	614
Backwater.....	771	Coal Consumption.....	643
Ball, Spinning, Deviation from Vertical Plane.....	828	Coal, Heat of Combustion.....	643
Balloon.....	644	Coefficient of Contraction.....	659
Barker's Mill.....	672	Coefficients of Efflux, 661, 712, 676, 734, 738, 784	784
Barometers ..	530	Coefficient of Fluid Friction, 707, 797	797
Barometric Levelling.....	619	Coefficient of Resistance.....	704
Bazin, Experiments.....	688	Coefficient of Roughness... 759, 760	760
Beaufoy's Experiments.....	814	Coefficient of Velocity, 661, 689, 704, 712, 723, 784	784
Bellinger, Prof., Experiments with Elbows.....	729	Collapse of Tubes.....	538
Bends, Loss of Head due to....	728	Communicating Prismatic Vessels.....	739
Bends in Open Channels.....	770	Complete and Perfect Contraction.....	676
Bent Tube, Liquids in.....	529	Component of Fluid Pressure..	525
Bernoulli's Theorem and the Conservation of Energy.....	717	Compressed-air Engine.....	631
Bernoulli's Theorem for Gases, 773	773	Compressed Air, Transmission of... ..	786
Bernoulli's Theorem, General Form.....	706	Compressibility of Water.....	516
Bernoulli's Theorem, Steady Flow without Friction... 652, 654	654	Conical Short Tubes.....	692
		Conservation of Energy and	xxii

INDEX TO HYDRAULICS.
(For index to "Mechanics of Solids" see p. xviii)

xxiii

	PAGE		PAGE
Bernoulli's Theorem.....	717	Equal Transmission of Fluid	
Contraction.....	659	Pressure.....	524
Contraction, Perfect.....	676	Equation of Continuity, 648, 737,	756
Cooling in Sudden Expansion		Equation of Continuity for	
of Gas.....	622	Gases.....	773
Critical Temperature of a Vapor,	608	Equation of Continuity for	
Croton Aqueduct, Slope.....	749	Open Channels.....	756
Cunningham, Experiments on		Equilibrium of Flotation.....	590
the River Ganges.....	759	Ericsson's Hot-air Engine.....	640
Cup-anemometer.....	824, 826	Ewart's Experiments on Jets... ..	600
Cups, Impulse of Jet on... ..	804, 808	Expanding Steam.....	625
Current, Transporting Power of,	880	Fahrenheit Scale.....	605
Current-meters.....	750	Fairbairn's Experiments on Col-	
Curved Dams.....	562	lapse of Tubes.....	538
Cylinders, Thin Hollow,		Fanning, Table of Coefficients	
Strength.....	579	of Fluid Friction.....	709
Dams, High Masonry.....	562	Feet and Meters, Table.....	677
Darcy, Experiments with Pitot's		Fire-engine Hose, Friction in... ..	716
Tube.....	804	Fire-streams, by Ellis.....	716
Darcy and Bazin, Experiments		Floating Staff.....	750
with Open Channels.....	758	Flood-gate.....	553
Decrease of Tension of Gas		Flotation.....	590
along a Pipe.....	798	Flow in Plane Layers.....	648, 652
Depth of Flotation.....	592	Flow in Open Channels.....	749
Deviation of Spinning Ball from		Flow of Gas in Pipes.....	786, 790
Vertical Plane... ..	823	Fluid Friction... ..	695, 797, 828
Diaphragm in a Pipe, Loss of		Fluid Friction, Coefficient for	
Head.....	724	Natural Gas.....	797
Displacement of a Ship.....	596	Fluid Pressure, Equal Trans-	
Divergent Tubes, Flow through,	692	mission of.....	524
Dividing Surface of Two Fluids,	528	Force-pump.....	667
Diving-bell.....	617	Francis' Formula for Overfalls,	687
Double Floats... ..	750	Free Surface of Liquid at Rest,	528
Draught of Ships.....	596	Free Surface a Paraboloid....	544
Dubuat's Experiments, 707, 815,		Fresh Water, Heaviness, Table,	518
822, 830		Friction-head in Open Channels,	757
Duchemin's Formula for Wind-		Friction-head in Pipes.....	699
pressure.....	818	Friction, Fluid... ..	695, 797, 828
Duty of Pumping-engines... ..	644	Froude's Experiments on Fluid	
Dynamics of Gaseous Fluids, 773-797		Friction.....	696
Earth Pressure.....	572	Froude's Experiments on Grad-	
Earthwork Dam.....	566	ual Enlargement in Pipes... ..	725
Eddy-making Resistance.. 814,	828	Froude's Experiments with	
Efficiency.....	637, 642	Piezometers.....	720
Efflux of Gases.....	773-797	Fteley and Stearns's Experi-	
Efflux from Steam-boiler.....	664	ments on Overfalls.....	687
Efflux from Vessel in Motion... ..	670	Fteley and Stearns's Experi-	
Efflux into Condenser.....	665	ments with Open Channels... ..	758
Efflux under Water.....	669	Gas and Vapor.....	607
Egg-shaped Section for Sewers,	765	Gas-engines.....	641
Elastic Fluids.....	516	Gaseous Fluids.....	604-645
Elbows, Loss of Head due to, 727,	729	Gas, Flow through Short Pipes,	784
Ellis, Book on Fire-streams... ..	716	Gas, Flow through Orifices... 773-784	
Emptying Vessels, Time of... 737-746		Gas, Illuminating... ..	517, 583
Engine, Gas.....	641	Gas, Natural, Flow in Pipes, 786,	790
Engine, Hot-air.....	639	Gas, Steady Flow.....	773
Engine, Petroleum.....	641	Gas, Velocity of Approach....	784
Engine, Steam.....	624	Gases, Definition.....	515
Enlargement, Sudden, in Pipe, 721		Gauging of Streams.....	755

(For index to "Mechanics of Solids" see p. xvii.)

	PAGE		PAGE
Gay-Lussac's Law.....	609	Jackson's Works on Hydraulics.....	761
Gradual Enlargement in Pipe..	735	Jet from Force-pump.....	667
Granular Materials.....	573	Jets, Impulse of.....	800, 803, 810
Graphic Representation of		Jets of Water.....	660, 662, 833
Change of State of Gas.....	628	Joule, Experiment on Flow of	
Head of Water.....	530	Gas.....	733
Heat-engines, Efficiency.....	642	Kansas City Water-works; Si-	
Heaviness of Fluids.....	517	phon.....	731, 736
Heaviness of Fresh Water at		Kinetic Energy.....	672, 718
Different Temperatures....	518	Kinetic Energy of Jet.....	672, 806
Height Due to Velocity.....	649	Kinetic Theory of Gases....	516,
Height of the Homogeneous		606, 622	
Atmosphere.....	620	Kutter's Diagram.....	761
Herschel's Venturi Water-meter,	736	Kutter's Formula.....	759
High Masonry Dams.....	562	Kutter's Hydraulic Tables.....	761
Hoop-tension.....	537	Laminated Flow.....	648, 652
Hose, Rubber and Leather, Fric-		Land-ties.....	535
tion in.....	716	Law of Charles.....	609
Hot-air Engines.....	639	Levelling, Barometric.....	619
Humphreys and Abbot's Survey		Liquefaction of Oxygen.....	609
of the Mississippi River...754,	759	Liquid, Definition.....	515
Hurdy-gurdy, California.....	809	Long Pipes, Flow of Water	
Hutton's Formula for Wind-		through.....	710-716
pressure.....	818	Loss of Head.....	698, 703, 721, etc.
Hydraulic Grade-line.....	715	Loss of Head Due to Bends....	728
Hydraulic Mean Depth, 698, 757,	764	Loss of Head Due to Elbows,	
Hydraulic Press.....	526	727, 729	
Hydraulic Radius.....	698	Loss of Head Due to Throttle-	
Hydraulic Radius for Minimum		valves.....	730
Friction.....	764	Loss of Head Due to Valve-	
Hydraulics, Definition.....	518	gates.....	730
Hydrodynamics.....	646-832	Manometers.....	530
Hydrodynamics or Hydrokinet-		Mariotte's Law.....	615, 777
ics. Definition.....	518	Mechanics of the Sail-boat....	819
Hydromechanics, Definition... 519		Mendeleeff's Device for Spec-	
Hydrometers.....	591	ula.....	544
Hydrometric Pendulum.....	753	Metacentre of a Ship.....	599
Hydrostatic Pressure.....	522	Metres and Feet, Table.....	677
Hydrostatics, Definition.....	518	Mill, Barker's.....	673
Ice-making Machine.....	624	Minimum Frictional Resistance	
Illuminating Gas.....	517, 538	in Open Channel.....	764, 766
Immersion of Rigid Bodies....	536	Mississippi River, Hydraulic	
Imperfect Contraction.....	680, 684	Survey.....	754, 759, 770
Impulse and Resistance of		Mixture of Gases.....	618
Fluids.....	797-832	Momentum, Principle of.....	813
Impulse of Jet on Vanes....	801, 805	Moving Pistons.....	524
Inclined Short Tubes, Efflux		Moving Vane, Impulse of Jet on	805
through.....	691	Napier on Flow of Steam.....	781
Incomplete Contraction....	679, 684	Natural Gas, Flow in Pipes, 791,	797
Inelastic Fluids.....	516	Natural Slope, of Earth.....	573
Irregular Shape, Emptying of		Non-planar Pistons.....	526
Vessels of.....	746	Notch, Rectangular, Efflux from,	
Isothermal Change....	615, 629, 639	633, 741	
Isothermal Expansion.....	624, 635	Obelisk-shaped Vessel; Time of	
Isothermal Flow of Gas in		Emptying.....	744
Pipes.....	790	Oblique Impact of Jet on Plate, 810	
Isothermal Flow of Gases		Open Channels, Flow in....	749-797
through Orifices.....	777	Orifices in Thin Plate.....	658, 773
Jacket of Hot Water.....	635	Otto Gas-engine.....	641, 648

INDEX TO HYDRAULICS.
(For index to "Mechanics of Solids" see p. xvii.)

XXV

	PAGE	PAGE	
Overfall, Emptying Reservoir through.....	741	Resistance, Wave-making.....	828
Overfall Weirs....677, 688, 698,	766	Resistance of Fluid to Moving Bodies.....	820
Overfall Weirs, Actual Discharge.....	688	Resistance of Fluid to Moving Plates.....	814
Paddle-wheel of a Steamer....	817	Resistance of Ships.....	828
Paraboloid as Free Surface....	544	Resistance of Still Water to Moving Solids.....	820
Paraboloidal Vessel.....	742	Retaining Walls.....	572-590
Parallelopipedical Reservoir Walls.....	555	Righting Couple, of Floating Body.....	597
Pelton Wheel or Hurdy-gurdy,	809	Ritchie-Haskell Direction Current-meter.....	750
Pendulum, Hydrometric.....	758	Rivers, Flow in.....	749-797
Perfect Fluid, Definition.....	515	Robinson, Prof., Experiments on Flow of Natural Gas....	797
Permanent Gases.....	605, 606	Robinson's Anemometer....	824, 826
Petroleum-engine.....	641	Rounded Orifice.....	663
Petroleum Pun-ping.....	708	Safety-valves.....	534
Piezometer.....	649, 657, 700	Sail-boat, Mechanics of the...	819
Pipes, Clean.....	708	Sail-boat Moving Faster than the Wind.....	820
Pipes, Foul.....	708	Saturated Steam, Heaviness ...	628
Pipes, Thickness of, for Strength.....	538	Saturated Vapor.....	607
Pipes, Tuberculated.....	706	Scouring Action of a Current..	830
Piston Pressures.....	523	Screw Propeller, Augment of..	829
Pistons, Moving.....	524	Sewers, Flow in.....	761, 765
Pistons, Non-planar.....	526	Ships, Resistance of.....	828
Pitot's Tube.....	751, 804, 827	Ships, Stability of.....	597, 599
Plate between Two Levels of Water.....	568, 569	Short Cylindrical Pipes, Efflux through.....	689, 704
Plates, Impulse of Jets on.....	801, 805, 810	Short Pipes.....	722, 728
Plates Moving in a Fluid....	813	Short Pipe, Minimum Head for Full Discharge.....	724
Plates, Resistance in Sea-water.	814	Simpson's Rule.....	608, 747, 748
Pneumatics, Definition.....	518	Siphons.....	735
Poisson's Law.....	621	Skin-friction.....	695, 828
Poncelet's Experiments with Overfalls.....	677	"Slip".....	829
Power Required to Propel Ships.....	830	Slope, in Open Channels.....	749
Pressure, Centre of.....	546	Smith, Mr. Hamilton; Hydraulics.....	689
Pressure on Bottom of a Vessel,	545	Smithsonian Scale of Wind-pressures.....	819
Pressure on Curved Surfaces...	569	Solid of Revolution, Impulse of Jet on.....	808
Pressure on Sluice-gate.....	551	Specific Gravity.....	589
Pressure per Unit-area.....	519	Sprengel's Air-pump.....	656
Pressure-energy.....	717	St. Gothard Tunnel, Experiments in.....	787
Pressure-head.....	650	Stability of Rectangular Wall..	554
Principle of Momentum.....	812	Stability of Ships.....	597
Pyramidal Vessel, Emptying of,	748	State of Permanency of Flow...	647
Quaker Bridge Dam, Proposed,	664	Steady Flow, Definition.....	647
Radian, Definition.....	544	Steady Flow, Experimental Phenomena.....	646
Reaction of a Water-jet.....	798	Steady Flow of a Gas.....	778
Rectangular Orifices.....	673, 676	Steam, Expanding.....	624
Refrigerator of Hot-air Engine,	640	Steam, Flow of.....	781
Regenerator of Hot-air Engine,	640	Steam, Saturated, Heaviness of..	628
Relative Equilibrium of a Liquid.....	540		
Reservoir of Irregular Shape, Emptying of.....	746		
Reservoir Walls.....	554-567		
Resistance, Eddy-making..	814, 828		

(For index to "Mechanics of Solids" see p. xvii.)

	PAGE		PAGE
Steam-engine, Examples.....	627	Vapors.....	516, 607
Steam-gauge, Bourdon.....	582	Variable Diameter, Long Pipe of,	794
Stirling's Hot-air Engine.....	689	Variable Motion in Open Chan-	
Stream-line.....	658	nels.....	768
Sudbury Conduit, Experiments,		Velocities in Section of River..	754
758, 762		Velocity of Efflux as related to	
Sudden Diminution of Section		Density.....	668
in a Pipe.....	727	Velocity-head.....	649
Sudden Enlargement of Section		Velocity Measurements in Open	
in a Pipe.....	721	Channel.....	750
Surface Floats.....	750	Vena Contracta.....	659
Survey, Hydraulic, of Missis-		Venturi's Tube.....	693
sippi River... ..754, 759		Venturi Tube, New Forms....	694
Tachometer.....	750	Venturi Water-meter.....	725
Temperature, Absolute.....	606	Volume of Reservoir Found by	
Temperature, Influence on		Observing Time of Emptying,	748
Flow of Water.....	708	Water, Compressibility of....	510
Tension of Gas.....	519	Water-formula for Flow of	
Tension of Illuminating Gas... ..	588	Gases.....	774
Thermodynamics.....	606	Water, Heaviness, at Different	
Thermometers.....	604	Temperatures.....	518
Thickness of Pipes.....	588	Water in Motion.....	646
Thickness of Pipe for Natural		Water-meter, Venturi.....	725
Gas.....	796	Water-ram.....	580, 588
Thin Hollow Cylinders.....	585	Wave-making Resistance.....	823
Thin Plate, Orifices in.....	658	Webb, Prof., Experiments on	
Throttle-valves, Loss of Head		the Reaction of Jets.....	800
Due to.....	780	Wedge of Maximum Thrust... ..	573
Time of Emptying Vessels of		Wedge-shaped Vessel, Time of	
Various Forms.....	737-746	Emptying.....	742
Transmission of Compressed		Weirs, Overfall... ..677, 683, 688,	
Air.....	786, 790	756, 772	
Transporting Power of a Cur-		Weisbach's Experiments... ..682,	
rent.....	880	685, 686, 691, 707, 721, 804	
Trapezoidal Section for Open		Weisbach's Experiments with	
Channel.....	765	Elbows and Bends.....	727, 728
Trapezoidal Wall, Stability of..	559	Weser, River, Backwater in....	772
Triangular Orifices.....	675	Wetted Perimeter.....	697, 749
Triangular Wall, Stability.....	561	Wex, von, Hydrodynamik....	688
Uniform Motion in Open Chan-		Whirling Machine.....	816, 826
nel.....	756	Wind-pressure.....	818
Uniform Rotation of Liquid... ..	542	Wind-pressure, Smithsonian	
Uniform Translation of Liquid..	540	Scale of.....	819
Upsetting Couple.....	599	Woltmann's Mill.....	750
Vacuum-chamber, in Siphon... ..	736	Work of Compressed-air En-	
Valve-gates, Loss of Head due		gine.....	681
to.....	780	Work of Expanding Steam....	624
Vanes, Impulse of Jets on... ..	801, 805	Work of Jet on a Vane.....	807





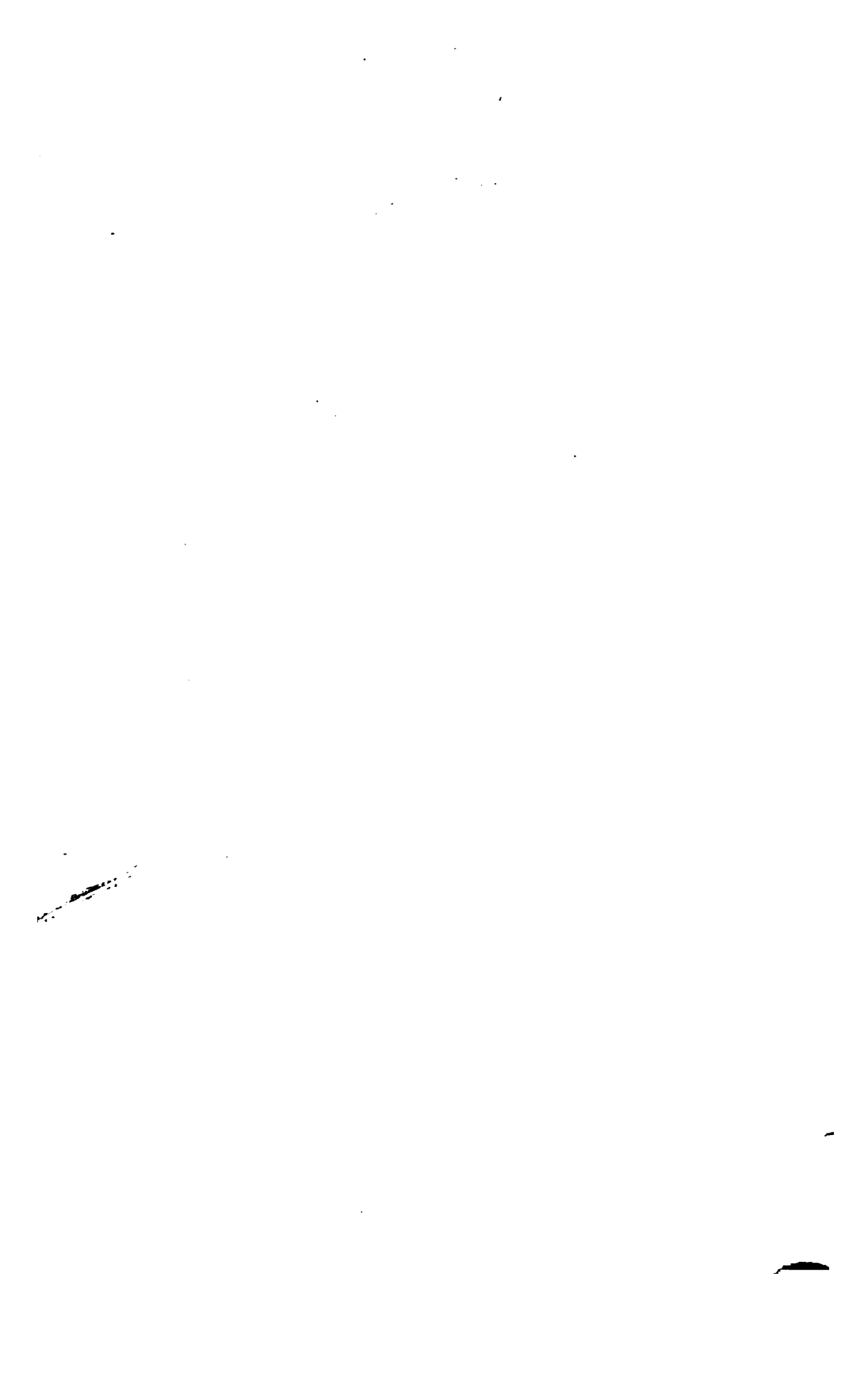

89080439094



889080439094A

may be kept

